



IMEN DATIS ASIA

Model DPV-1 Dry Pipe Valve External Resetting

General Description

The TYCO Model DPV-1 Dry Pipe Valves are differential valves used to automatically control the flow of water into dry pipe fire protection sprinkler systems upon operation of one or more automatic sprinklers. The DPV-1 also provides for actuation of fire alarms upon system operation. The Model DPV-1 features are as follows:

- External reset.
- 250 psi (17,2 bar) pressure rating.
- Unique offset single clapper design enabling a simple compact valve to minimize installation labor.
- Ductile iron construction to ensure a lightweight valve to minimize shipping cost.
- A variety of inlet and outlet connections.
- Compact, Pre-Trimmed, and Semi-Assembled, easy to operate valve trim.
- Simple reset procedure through the elimination of priming water.

Dry pipe sprinkler systems are used in unheated warehouses, parking garages, store windows, attic spaces, loading docks, and other areas exposed to freezing temperatures, where water filled pipe cannot be utilized. When set for service, the dry pipe sprinkler system is pressurized with air (or nitrogen). The loss of pressure through an operated automatic sprinkler in response to heat from a fire permits the DPV-1 Dry Pipe Valve to open and allow a flow of water into the sprinkler system piping. Table B establishes the minimum required system air pressure that includes a safety factor to help prevent false operations that might occur due to water supply fluctuations.



Available Sizes and End Connections

End Connection	Nominal Valve Size			
	2-1/2 Inch (DN65)	3 Inch (DN80)	4 Inch (DN100)	6 Inch (DN150)
Flange x Flange	N/A	N/A	•	•
Flange x Groove	N/A	N/A	•	•
Groove x Groove	•	•	•	•

• = Available
N/A = Not Available

NOTICE

The Model DPV-1 Dry Pipe Valves described herein must be installed and maintained in compliance with this document, as well as with the applicable standards of the National Fire Protection Association, in addition to the standards of any other authorities having jurisdiction. Failure to do so may impair the performance of these devices.

The owner is responsible for maintaining their fire protection system and devices in proper operating condition. Contact the installing contractor or product manufacturer with any questions.

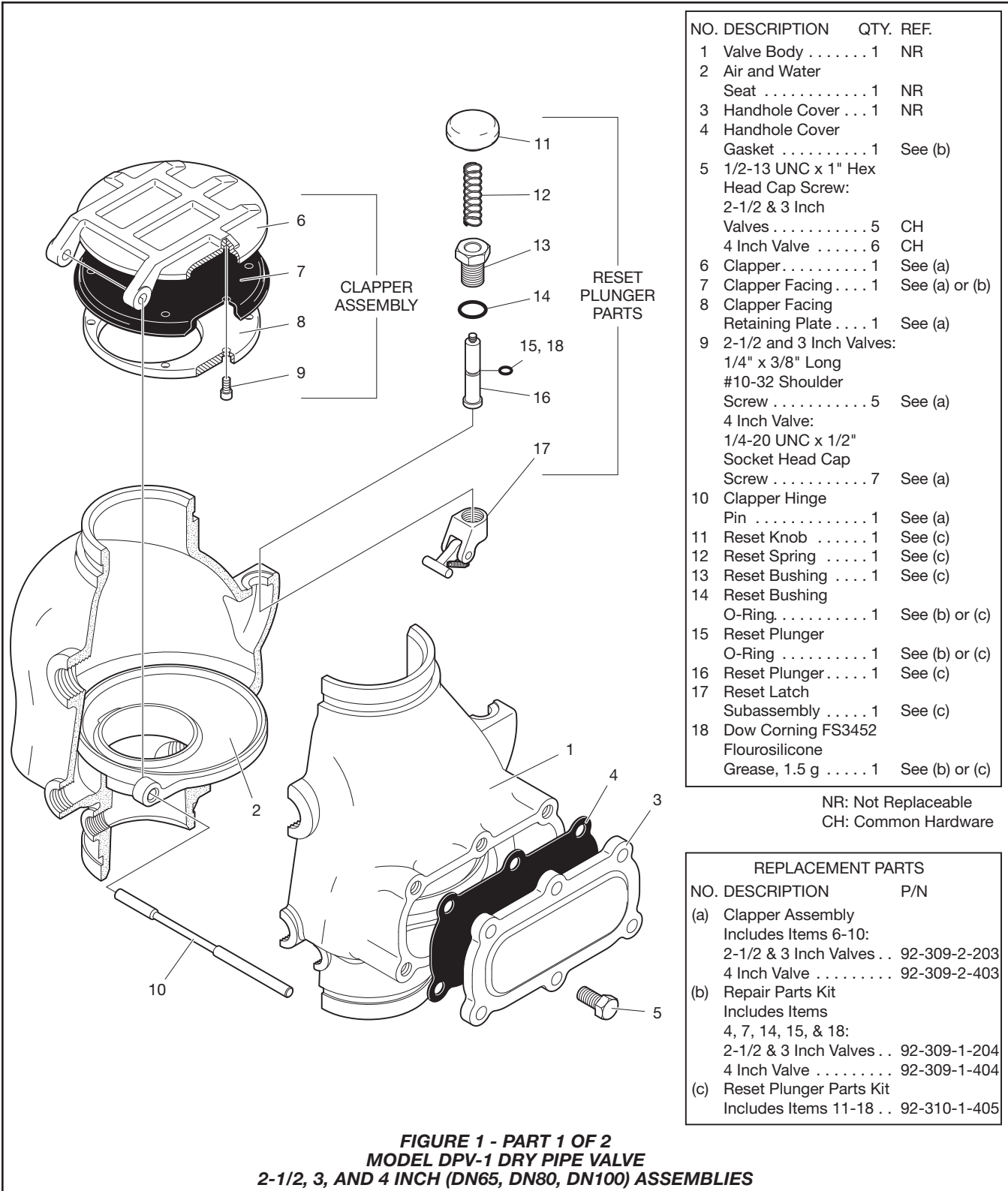

NO.	DESCRIPTION	QTY.	REF.
1	Valve Body	1	NR
2	Air and Water Seat	1	NR
3	Handhole Cover	1	NR
4	Handhole Cover Gasket	1	See (b)
5	1/2-13 UNC x 1" Hex Head Cap Screw: 2-1/2 & 3 Inch Valves	5	CH
	4 Inch Valve	6	CH
6	Clapper	1	See (a)
7	Clapper Facing	1	See (a) or (b)
8	Clapper Facing Retaining Plate	1	See (a)
9	2-1/2 and 3 Inch Valves: 1/4" x 3/8" Long #10-32 Shoulder Screw	5	See (a)
	4 Inch Valve: 1/4-20 UNC x 1/2" Socket Head Cap Screw	7	See (a)
10	Clapper Hinge Pin	1	See (a)
11	Reset Knob	1	See (c)
12	Reset Spring	1	See (c)
13	Reset Bushing	1	See (c)
14	Reset Bushing O-Ring	1	See (b) or (c)
15	Reset Plunger O-Ring	1	See (b) or (c)
16	Reset Plunger	1	See (c)
17	Reset Latch Subassembly	1	See (c)
18	Dow Corning FS3452 Fluorosilicone Grease, 1.5 g	1	See (b) or (c)

NR: Not Replaceable
CH: Common Hardware

REPLACEMENT PARTS		
NO.	DESCRIPTION	P/N
(a)	Clapper Assembly Includes Items 6-10:	
	2-1/2 & 3 Inch Valves	92-309-2-203
	4 Inch Valve	92-309-2-403
(b)	Repair Parts Kit Includes Items 4, 7, 14, 15, & 18:	
	2-1/2 & 3 Inch Valves	92-309-1-204
	4 Inch Valve	92-309-1-404
(c)	Reset Plunger Parts Kit Includes Items 11-18	92-310-1-405

**FIGURE 1 - PART 1 OF 2
MODEL DPV-1 DRY PIPE VALVE
2-1/2, 3, AND 4 INCH (DN65, DN80, DN100) ASSEMBLIES**

NO.	DESCRIPTION	QTY.	REP. PART
1	Valve Body	1	NR
2	Air and Water Seat	1	NR
3	Water Seal O-Ring	1	NR
4	Air Seal O-Ring	1	NR

NO.	DESCRIPTION	QTY.	REP. PART
5	Socket Head Cap Screw	8	NR
6	Handhole Cover	1	NR
7	Handhole Cover Gasket	1	See (b)

NO.	DESCRIPTION	QTY.	REP. PART
8	Hex Head Cap Screw	6	CH
9	Clapper	1	See (a)
10	Clapper Facing	1	See (a) or (b)
11	Clapper Facing Retaining Plate	1	See (a)
12	Socket Head Cap Screw	1	See (a)
13	Clapper Hinge Pin	1	See (a)
14	Reset Knob	1	See (c)
15	Reset Spring	1	See (c)
16	Reset Bushing	1	See (c)
17	Reset Bushing O-Ring	1	See (b) or (c)
18	Reset Plunger O-Ring	1	See (b) or (c)
19	Reset Plunger	1	See (c)
20	Reset Latch Subassembly	1	See (c)
21	Dow Corning FS3452 Fluorosilicone Grease, 1.5 g	1	See (b) or (c)

NR: Not Replaceable
CH: Common Hardware

REPLACEMENT PARTS		
NO.	DESCRIPTION	P/N
(a)	Clapper Assembly Includes Items 9-13	92-309-2-603
(b)	Repair Parts Kit Includes Items 7, 10, 17, 18, 21	92-309-1-604
(c)	Reset Plunger Kit Includes Items 14-21	92-310-1-405

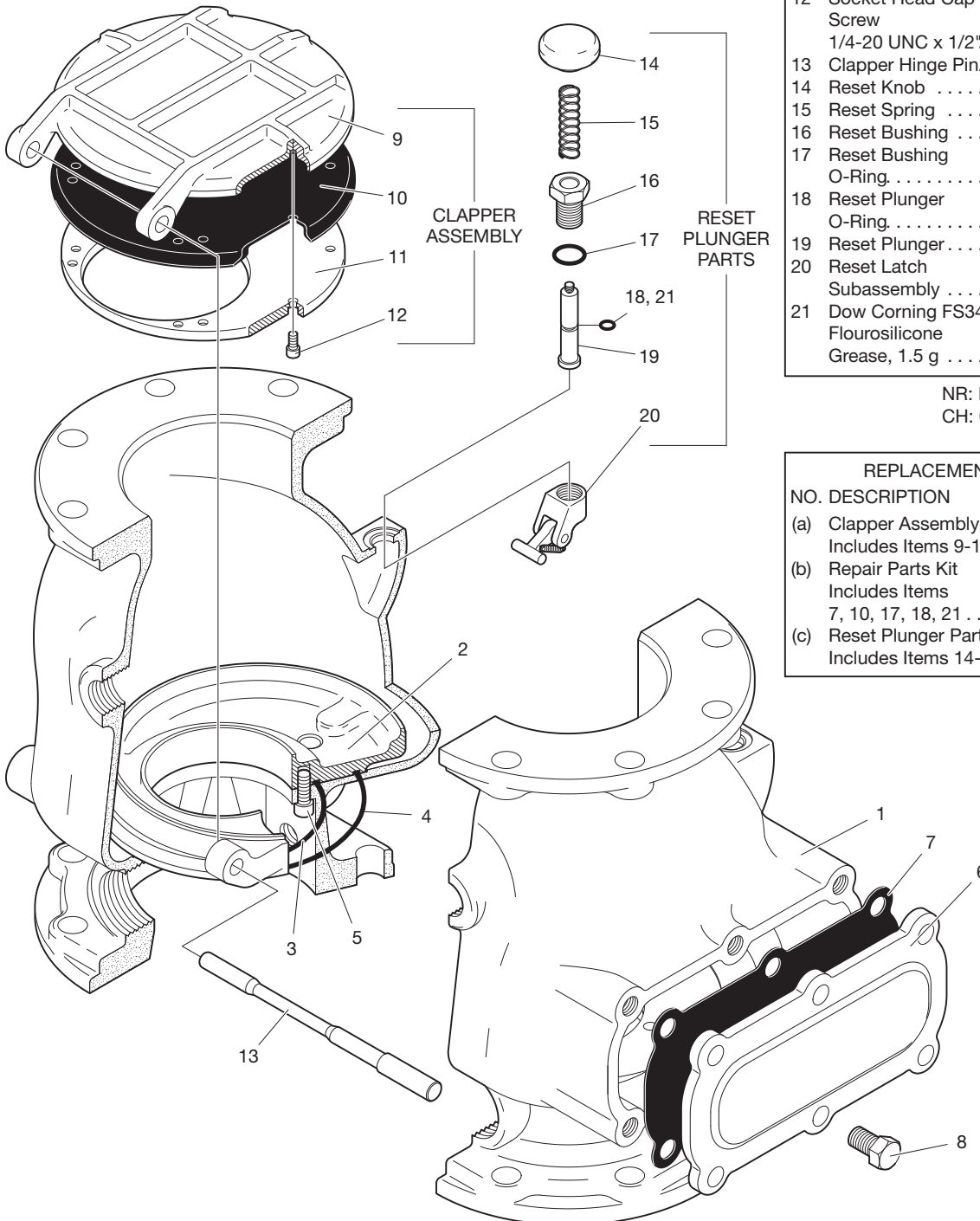

**FIGURE 1 - PART 2 OF 2
MODEL DPV-1 DRY PIPE VALVE
6 INCH (DN150) ASSEMBLY**

Technical Data

Approvals

UL and C-UL Listed. FM Approved. NYC under MEA 172-02-E (4 and 6 inch).

Dry Pipe Valve

The TYCO Model DPV-1 Dry Pipe Valves are for vertical installations (flow going up), and they are rated for use at a maximum service pressure of 250 psi (17,2 bar). The Valve dimensions are shown in Figure 7.

Flanged connections are available and drilled per ANSI, ISO, AS, and JIS specifications (Ref. Table A). The grooved outlet connections, as applicable, are cut in accordance with standard groove specifications for steel pipe. They are suitable for use with grooved end pipe couplings that are listed or approved for fire protection system service. Available combinations of inlet and outlet connections are detailed in the Ordering Procedure section. They are also noted in the "Available End Connection and Sizes" table located on Page 1.

Threaded port connections of valves having flanges drilled to ANSI, AS, or JIS specifications are NPT threaded per ANSI Standard B1.20.1. Threaded port connections of valves having flanges drilled to ISO are available either threaded per ISO 7-1 or NPT threaded per ANSI Standard B1.20.1. Valves with NPT threaded ports will readily accept the trim arrangements detailed in Parts 2 and 3 of Figures 4, 5, and 6.

Components of the DPV-1 Valves are shown in Figure 1. The Body and Handhole Cover are ductile iron. The Handhole Cover Gasket is neoprene, and the Clapper Facing is EPDM. The Air/Water Seat Ring is brass, the Clapper is bronze or aluminum bronze,

and both the Clapper Retaining Plate and Latch are bronze. The Hinge Pin is aluminum bronze, and the fasteners for the Handhole Cover are carbon steel.

Valve Trim

Installation dimensions are given in Figure 7, and the Valve Trim and Pre-Trimmed Valve Assemblies are illustrated in Figures 4, 5, and 6. The Valve Trim and Pre-Trimmed Valve forms a part of the laboratory listings and approval of the DPV-1 Valve and is necessary for the proper operation of the DPV-1 Valve. Each package of trim and pre-trimmed includes the following items:

- Water Supply Pressure Gauge
- System Air Pressure Gauge
- Air Supply Connections
- Main Drain Valve
- Low Body Drain Valve
- Alarm Test Valve
- Automatic Drain Valve
- Drip Funnel
- Connections For Optional Quick Opening Device (Accelerator)

Also included in the Pre-Trimmed Valve Assembly, which can be ordered separately for the Valve Trim, includes the following items:

- Model BFV-N butterfly valve
- Figure 577 grooved coupling
- PS10-2 waterflow alarm switch
- PS40-2 low air pressure alarm switch

Note: When the system pressure is greater than 175 psi (12,1 bar), provision is to be made to replace the standard order 300 psi (20,7 bar) Water Pressure gauge with a separately ordered 600 psi (41,4 bar) Water Pressure Gauge.

Air Supply

Table B shows the system air pressure requirements as a function of the water supply pressure. The air (or nitrogen) pressure in the sprinkler system is recommended to be automatically maintained by using one of the following pressure maintenance devices, as appropriate:

- Model AMD-1 Air Maintenance Device (pressure reducing type).
- Model AMD-2 Air Maintenance Device (compressor control type).
- Model AMD-3 Nitrogen Maintenance Device (high pressure reducing type).

The Pressure Relief Valve provided with the valve trim is factory set to relieve at a pressure of approximately 45 psi (3,1 bar). If the normal system air pressure is less than or exceeds 40 psi (2,8 bar), then the pressure Relief Valve must be reset to relieve at a pressure that is in accordance with the authority having jurisdiction.

Quick Opening Device

As an option, the Model DPV-1 Dry Pipe Valve may be equipped with the VIZOR Electronic Dry Pipe Valve Accelerator (4 and 6 inch sizes) as detailed in Technical Data Sheet TFP1105 or the Model ACC-1 Mechanical Dry Pipe Valve Accelerator (2-1/2, 3, 4, and 6 inch sizes) as detailed in Technical Data Sheet TFP1112.

The VIZOR or the ACC-1 is used to reduce the time to valve actuation following the operation of one or more automatic sprinklers. In some cases the use of a quick opening device such as the VIZOR or the ACC-1 may be required to meet the requirements of the National Fire Protection Association to meet water delivery times.

Nominal Valve Size	Flange Drilling Specification											
	Nominal Dimensions in Inches and (mm)											
	ANSI B16.11 (Class 125)			ISO 7005-2 (PN16) ²			JIS B 2210 (10K)			AS 2129 (Table E)		
	Dim. A	Dim. B	Qty. N	Dim. A	Dim. B	Qty. N	Dim. A	Dim. B	Qty. N	Dim. A	Dim. B	Qty. N
4 Inch (DN100)	7.50 (190,5)	0.75 (19,0)	8	7.09 (180,0)	0.75 (19,0)	8	6.89 (175,0)	0.59 (15,0)	8	7.00 (178,0)	0.71 (18,0)	8
6 Inch (DN150)	9.50 (241,3)	0.88 (22,2)	8	9.45 (240,0)	0.91 (23,0)	8	9.45 (240,0)	0.75 (19,0)	8	9.25 (235,0)	0.87 (22,0)	8

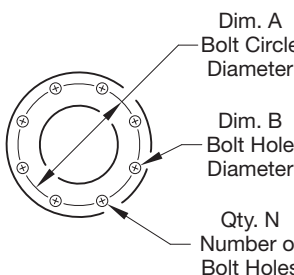

Dim. A Bolt Circle Diameter

Dim. B Bolt Hole Diameter

Qty. N Number of Bolt Holes

1. Drilling same as ANSI B16.5 (Class 150) and ANSI B16.42 (Class 150).
 2. Drilling same as BS 4504 Section 3.2 (PN16) and DIN 2532 (PN16).

TABLE A
DIMENSIONAL SPECIFICATIONS
FOR SELECTION OF FLANGE DRILLING

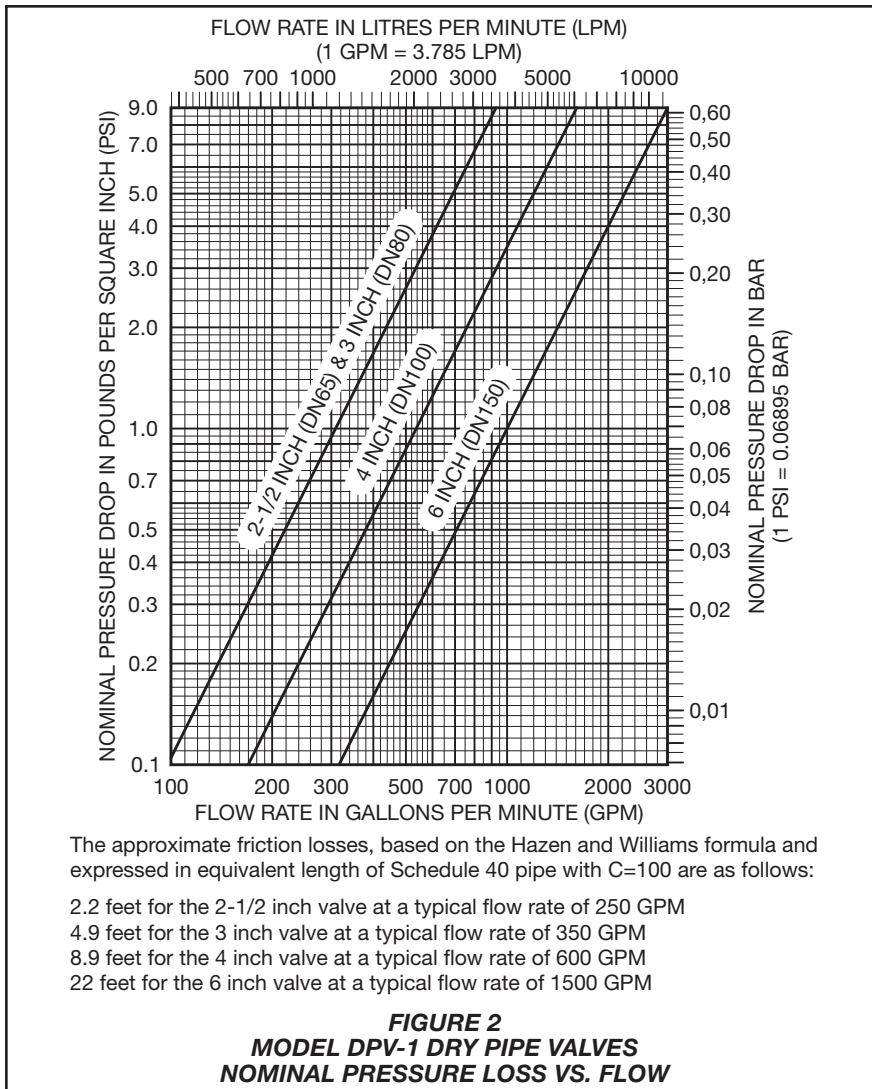

Maximum Water Supply Pressure psi	System Air Pressure Range psi
20	10
60	15 - 23
80	20 - 28
100	25 - 33
120	30 - 38
145	35 - 43
165	40 - 48
185	45 - 53
205	50 - 58
225	55 - 63
250	60 - 68

**TABLE B
SYSTEM AIR PRESSURE REQUIREMENTS**

the resetting steps, as well as during inspections, making certain that the Automatic Drain Valve is open.

When one or more automatic sprinklers operate in response to a fire, air pressure within the system piping is relieved through the open sprinklers. When the air pressure is sufficiently reduced, the water pressure overcomes the differential holding the Clapper Assembly closed and the Clapper Assembly swings clear of the water seat, as shown in Figure 3C. This action permits water flow into the system piping and subsequently to be discharged from any open sprinklers. Also, with the Clapper Assembly open, the intermediate chamber is pressurized and water flows through the alarm port (Ref. Figure 3B) at the rear of the DPV-1 Valve to actuate system water flow alarms. The flow from the alarm port is also sufficient to close the otherwise normally open Automatic Drain Valve in the valve trim.

After a valve actuation and upon subsequent closing of a system main control valve to stop water flow, the Clapper Assembly will latch open as shown in Figure 3D. Latching open of the DPV-1 will permit complete draining of the system (including any loose scale) through the main drain port.

During the valve resetting procedure and after the system is completely drained, the external reset knob can be easily depressed to externally unlatch the Clapper Assembly, as shown in Figure 3E. As such, the Clapper Assembly is returned to its normal set position to facilitate setting of the dry pipe sprinkler system, without having to remove the Handhole Cover.

Operation

The TYCO Model DPV-1 Dry Pipe Valve is a differential type valve that utilizes a substantially lower system (air or nitrogen) pressure than the supply (water) pressure, to maintain the set position shown in Figure 3A. The differential nature of the DPV-1 is based on the area difference between the air seat and the water seat in combination with the ratio of the radial difference from the Hinge Pin to the center of the Water Seat and the Hinge Pin to the center of the Air Seat. The difference is such that 1 psi (0,07 bar) of system air pressure can hold approximately 5.5 psi (0,38 bar) of water supply pressure.

Table B establishes the minimum required system air pressure that includes a safety factor to help prevent false operations that occur due to water supply fluctuations.

The Intermediate Chamber of the DPV-1 is formed by the area between the Air Seat and Water Seat as shown in

Figure 3B. The Intermediate Chamber normally remains at atmospheric pressure through the Alarm Port connection and the valve trim to the normally open Automatic Drain Valve (Fig. 4, 5, or 6). Having the Intermediate Chamber, Figure 3B, open to atmosphere is critical to the DPV-1 Valve remaining set, otherwise the full resulting pressure of the system air pressure on top of the Clapper Assembly cannot be realized.

For example, and assuming a water supply pressure of 100 psi (6,9 bar), if the system air pressure is 25 psi (1,7 bar) and there was 15 psi (1,0 bar) pressure trapped in the Intermediate Chamber, the resulting pressure across the top of the Clapper would only be 10 psi (0,7 bar). This pressure would be insufficient to hold the Clapper Assembly closed against a water supply pressure of 100 psi (6,9 bar). It is for this reason that the plunger of the Automatic Drain Valve must be depressed during several of

IMEN DATIS ASIA

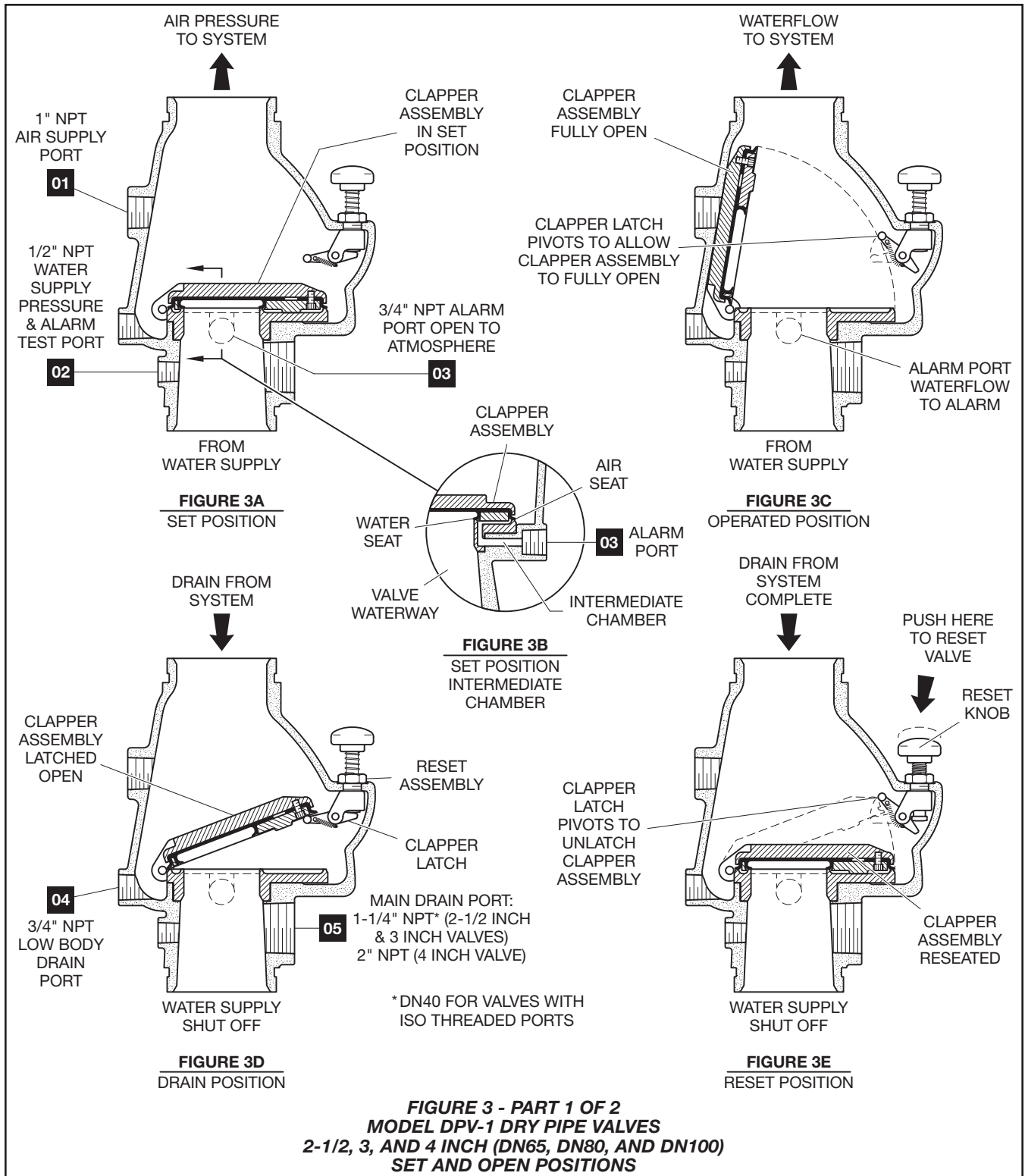

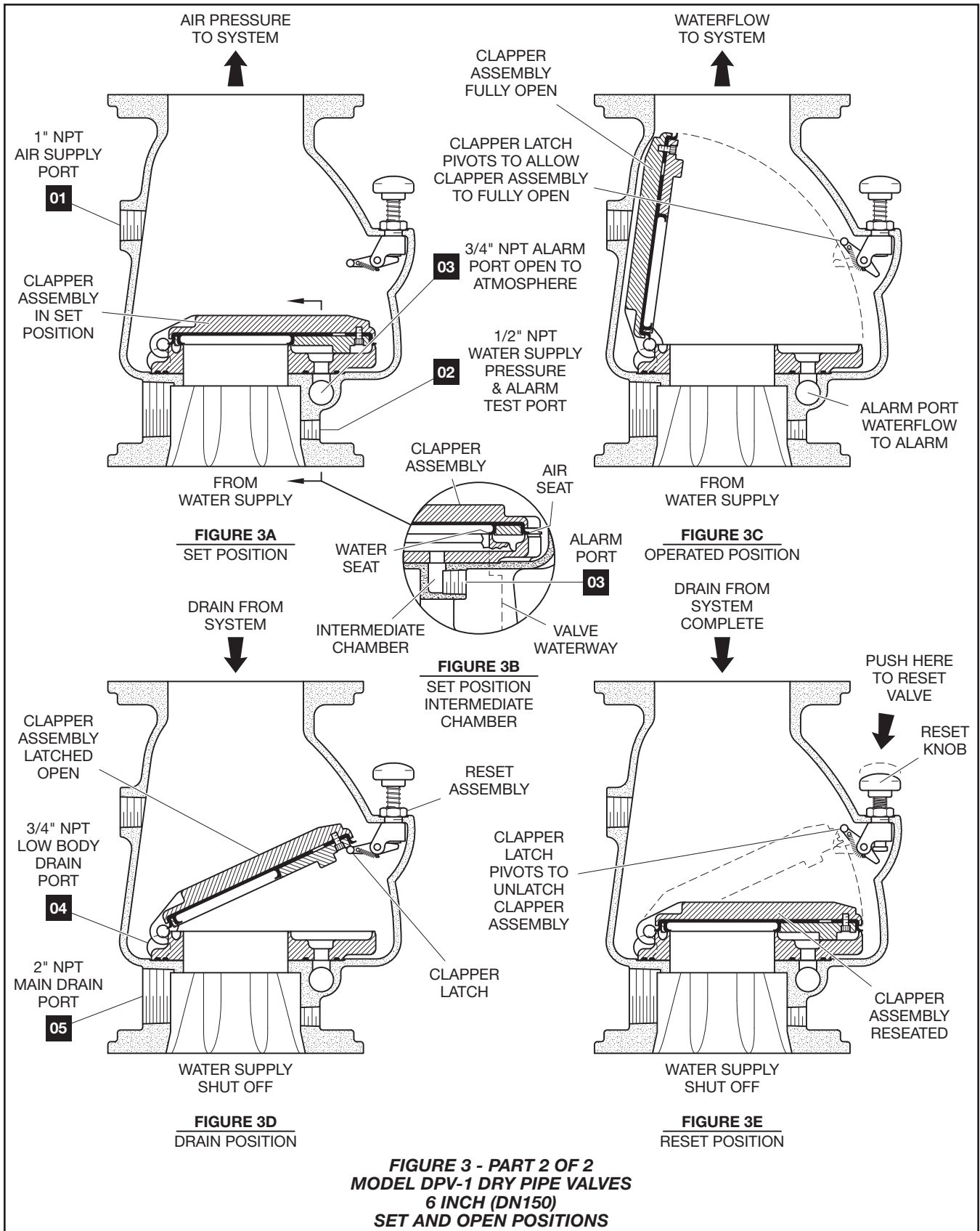

**FIGURE 3 - PART 2 OF 2
MODEL DPV-1 DRY PIPE VALVES
6 INCH (DN150)
SET AND OPEN POSITIONS**

NOTES:

1. SEE FIGURE 4 PART 3 FOR TRIM ARRANGEMENT WITH BILL OF MATERIALS AND COMPONENT PART NUMBERS.
2. TRIM SHOWN FULLY ASSEMBLED; COMPONENTS SUCH AS GAUGES AND SWITCHES MAY REQUIRE ASSEMBLY IN TRIM AT INSTALLATION.

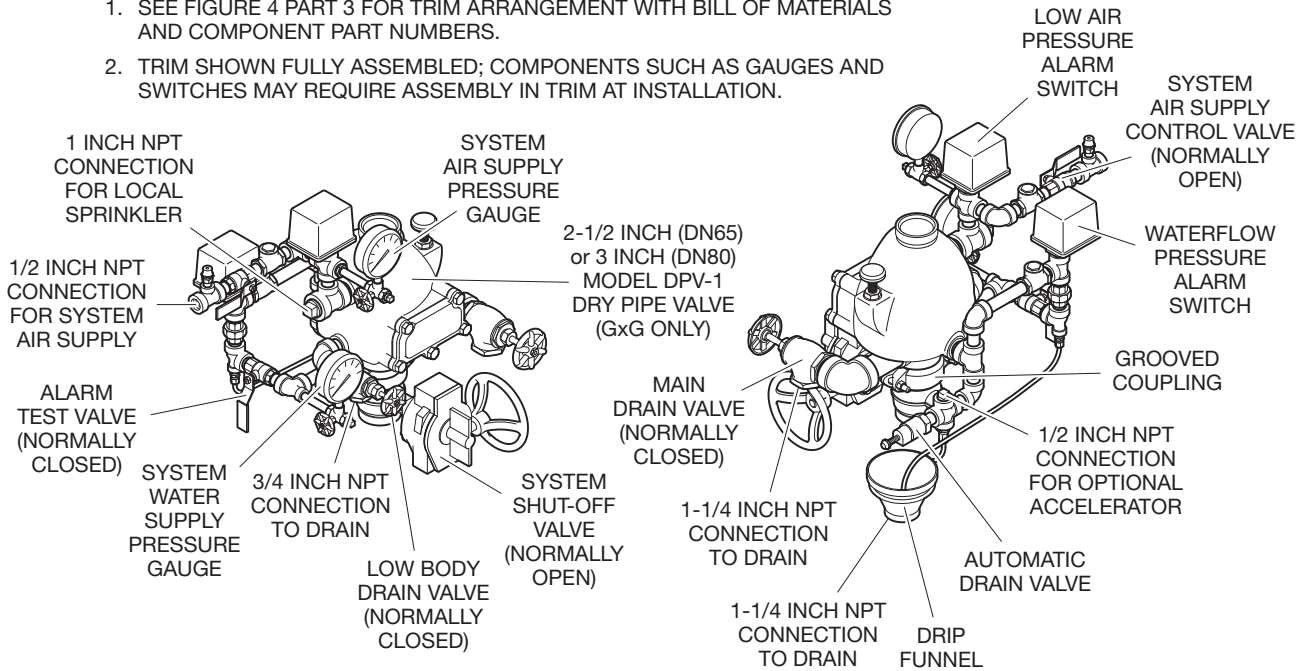
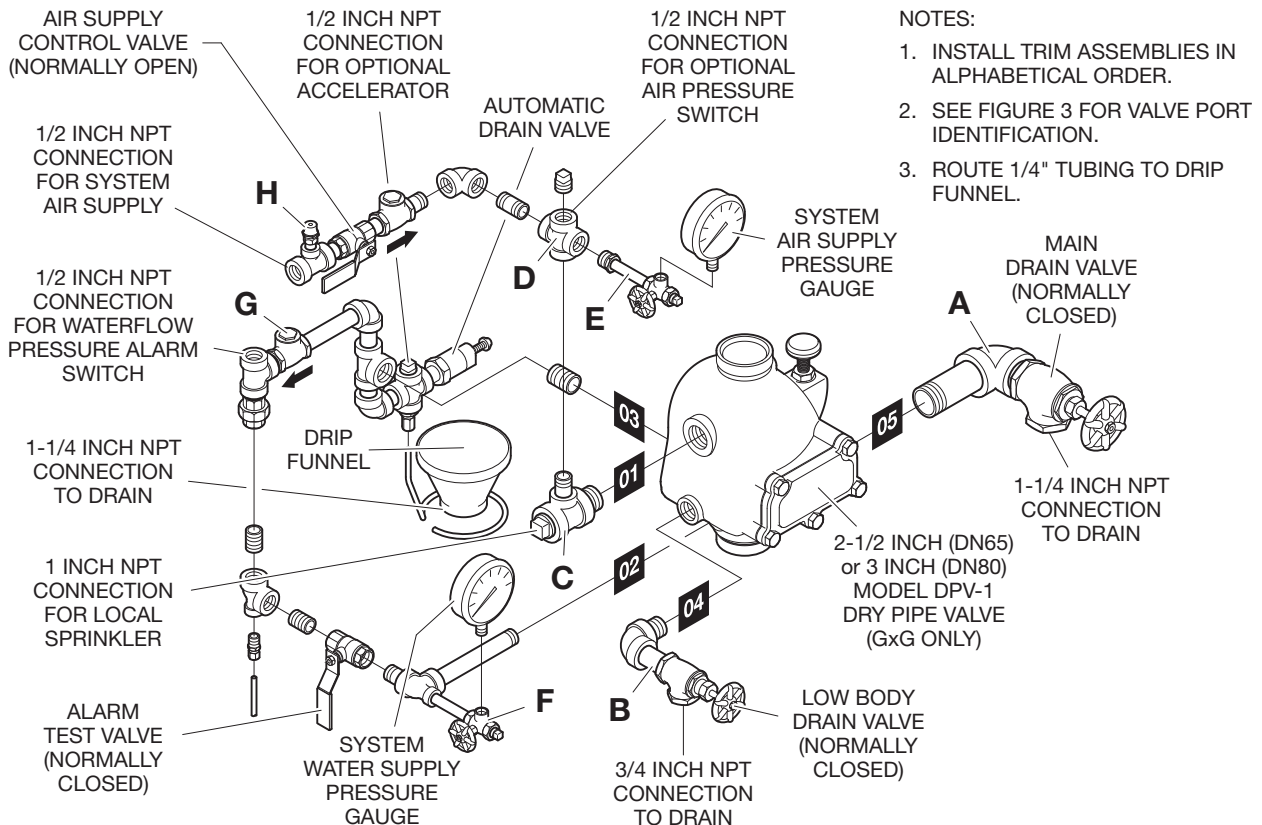

FIGURE 4 - PART 1 OF 3
2-1/2 AND 3 INCH (DN65 AND DN80) MODEL DPV-1 DRY PIPE VALVE
PRE-TRIMMED ASSEMBLY



NOTES:

1. INSTALL TRIM ASSEMBLIES IN ALPHABETICAL ORDER.
2. SEE FIGURE 3 FOR VALVE PORT IDENTIFICATION.
3. ROUTE 1/4" TUBING TO DRIP FUNNEL.

FIGURE 4 - PART 2 OF 3
2-1/2 AND 3 INCH (DN65 AND DN80) MODEL DPV-1 DRY PIPE VALVE
EXPLODED ARRANGEMENT OF SEMI-ASSEMBLED TRIM

NO.	DESCRIPTION	QTY.	P/N
1	250 psi/ 1750 kPa Air Pressure Gauge	1	92-343-1-012
2	300 psi/ 2000 kPa Water Pressure Gauge	1	92-343-1-005
3	1/4" Gauge Test Valve	2	46-005-1-002
4	Model AD-1 Automatic Drain Valve	1	52-793-2-004
5	1/4" Pressure Relief Valve	1	92-343-1-020
6	1/2" Ball Valve	2	46-050-1-004
7	3/4" Angle Valve	1	46-048-1-005
8	1-1/4" Angle Valve	1	46-048-1-007
9	1/2" Swing Check Valve	2	46-049-1-004
10	Drip Funnel Connector	1	92-211-1-005
11	Drip Funnel Bracket	1	92-211-1-003
12	Drip Funnel	1	92-343-1-007

NO.	DESCRIPTION	QTY.	P/N
13	3/32" Vent Fitting	1	92-032-1-002
14	1/4" Tube, 18" Long	1	CH
15	1/4" Plug	2	CH
16	1/2" Plug	2	CH
17	1" Plug	1	CH
18	1/2" Union	1	CH
19	1/2" x 1/4" Reducing Bushing	1	CH
20	1/2" 90° Elbow	3	CH
21	3/4" 90° Elbow	1	CH
22	1-1/4" 90° Elbow	1	CH
23	1/2" Cross	2	CH
24	1/2" x 1/2" x 1/4" Reducing Tee	1	CH
25	1/2" Tee	1	CH
26	1/2" x 1/4" x 1/2" Reducing Tee	2	CH
27	1/2" x 1/2" x 3/4" Reducing Tee	1	CH

NO.	DESCRIPTION	QTY.	P/N
28	1" x 1" x 1/2" Reducing Tee	1	CH
29	Not Used		
PIPE NIPPLES:			
30	1/4" x 3"	2	CH
31	1/2" x Close	4	CH
32	1/2" x 1-1/2"	8	CH
33	1/2" x 2"	1	CH
34	1/2" x 4-1/2"	1	CH
35	1/2" x 6"	1	CH
36	3/4" x Close	1	CH
37	3/4" x 1-1/2"	1	CH
38	3/4" x 2-1/2"	1	CH
39	1" x Close	1	CH
40	1-1/4" x Close	1	CH
41	1-1/4" x 4"	1	CH

COMPONENTS INCLUDED ONLY IN PRE-TRIMMED VALVE ASSEMBLIES:

42	Model BFV-N Butterfly Valve, 2-1/2" (DN65)	1	59300F025N
	3" (DN80)	1	59300F030N
43	Figure 577 Coupling, 2-1/2" (DN65)	1	57725ACP
	3" (DN80)	1	57730ACP
44	Waterflow Pressure Alarm Switch, Model PS10-2	1	25710
45	Low Air Pressure Alarm Switch, Model PS40-2	1	25730

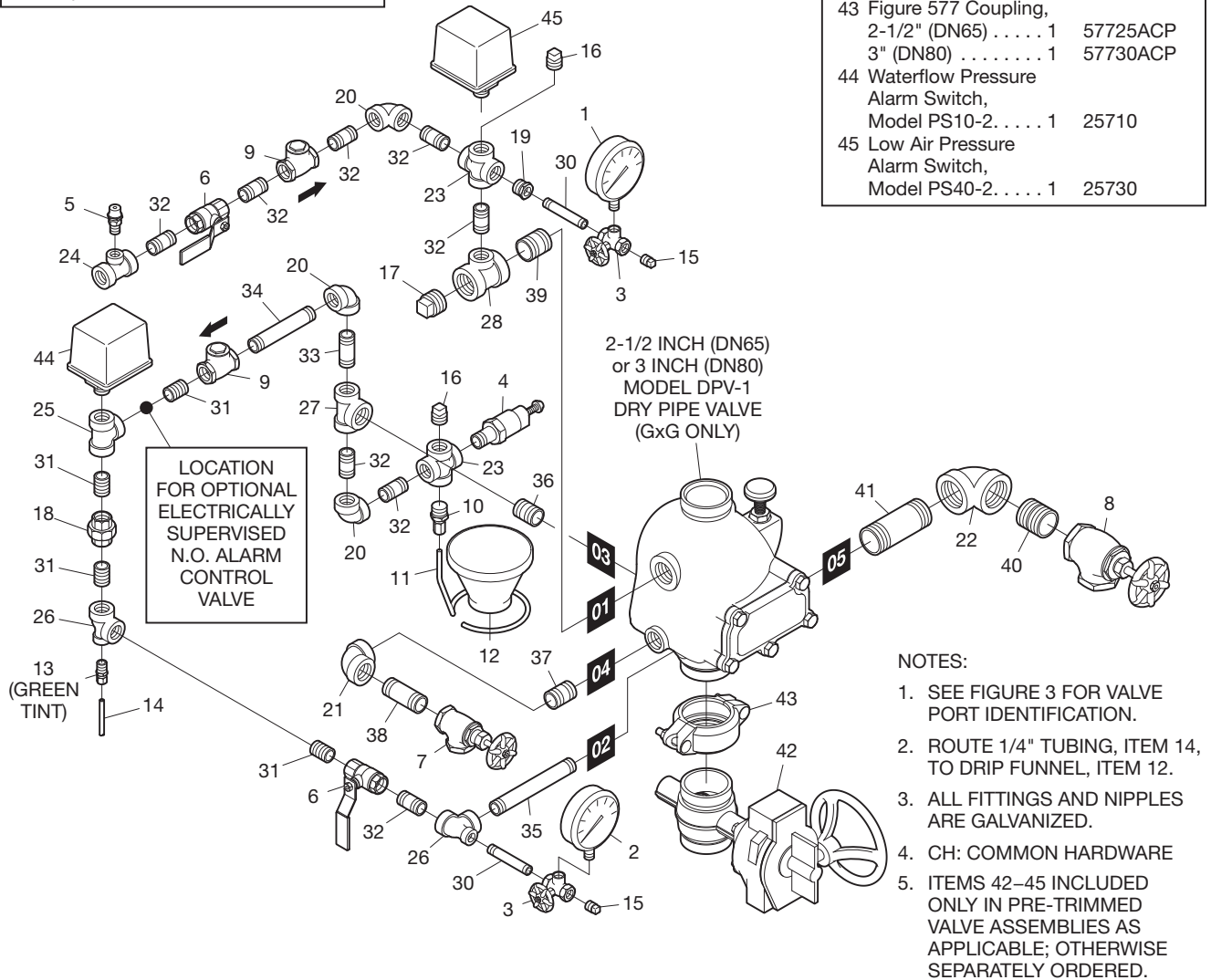

FIGURE 4 - PART 3 OF 3
2-1/2 AND 3 INCH (DN65 AND DN80) MODEL DPV-1 DRY PIPE VALVE
EXPLODED ARRANGEMENT OF VALVE TRIM

1. SEE FIGURE 5 PART 3 FOR TRIM ARRANGEMENT WITH BILL OF MATERIALS AND COMPONENT PART NUMBERS.
2. TRIM SHOWN FULLY ASSEMBLED; COMPONENTS SUCH AS GAUGES AND SWITCHES MAY REQUIRE ASSEMBLY IN TRIM AT INSTALLATION.

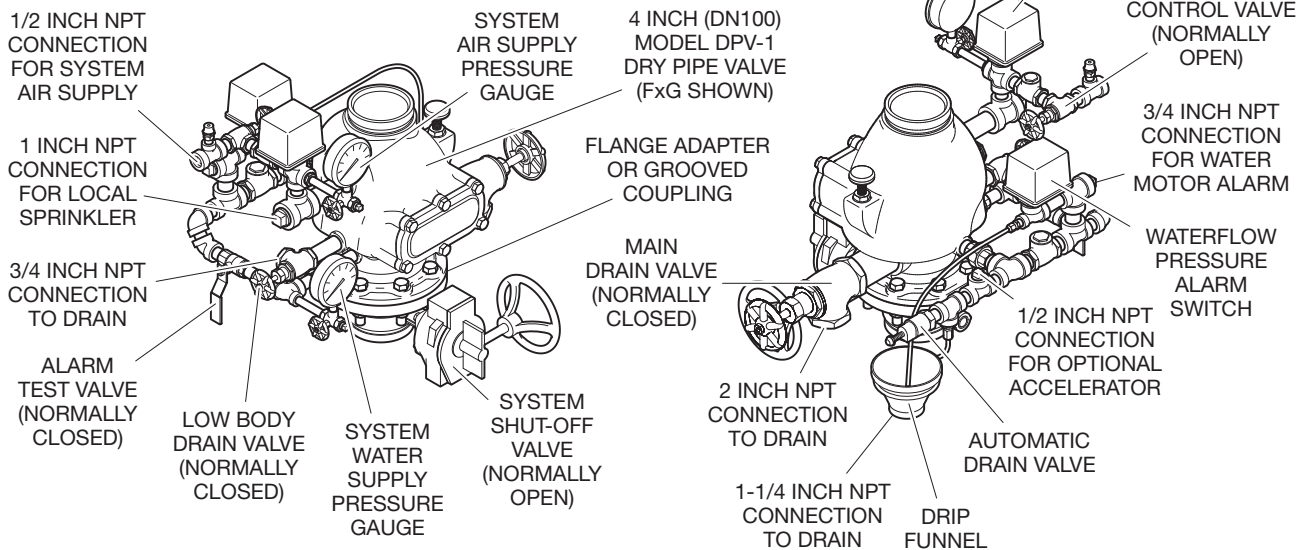
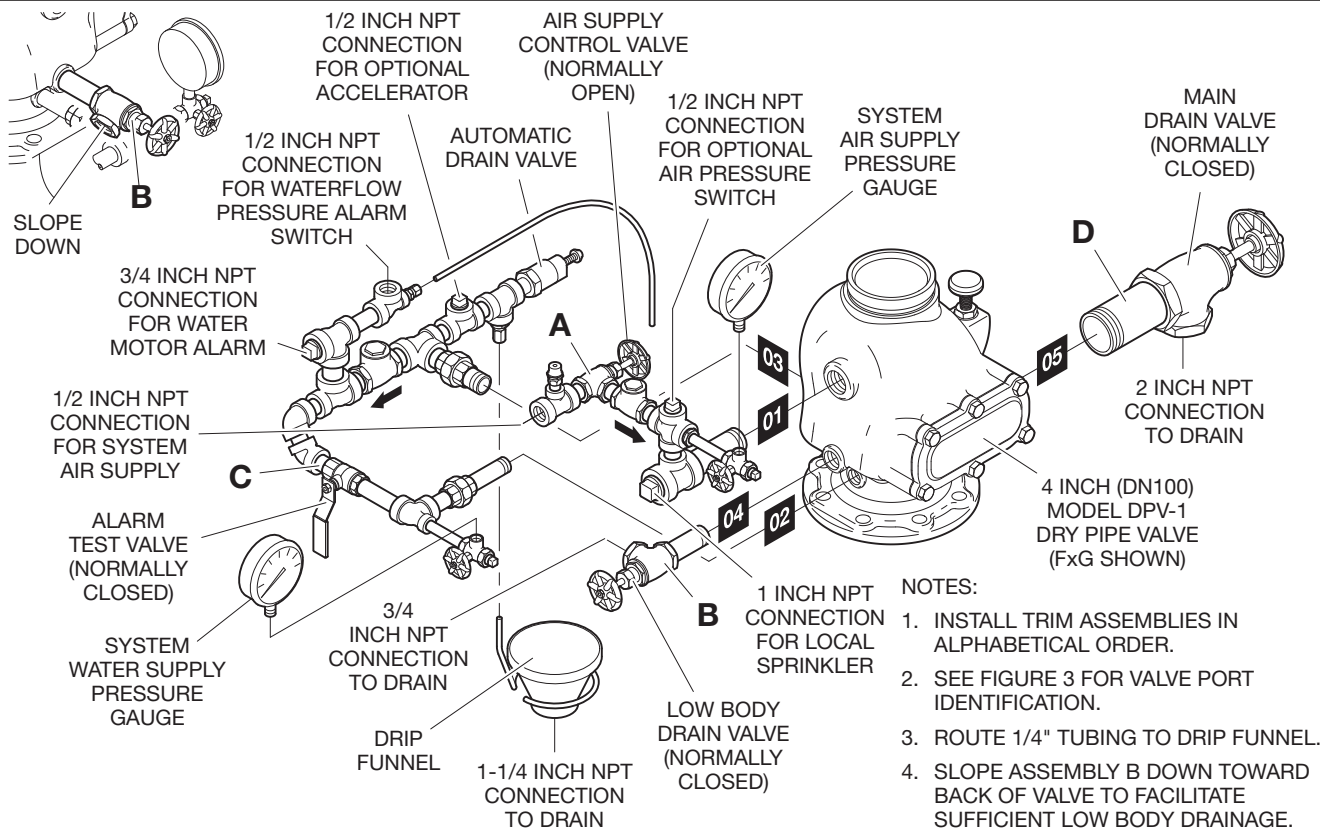
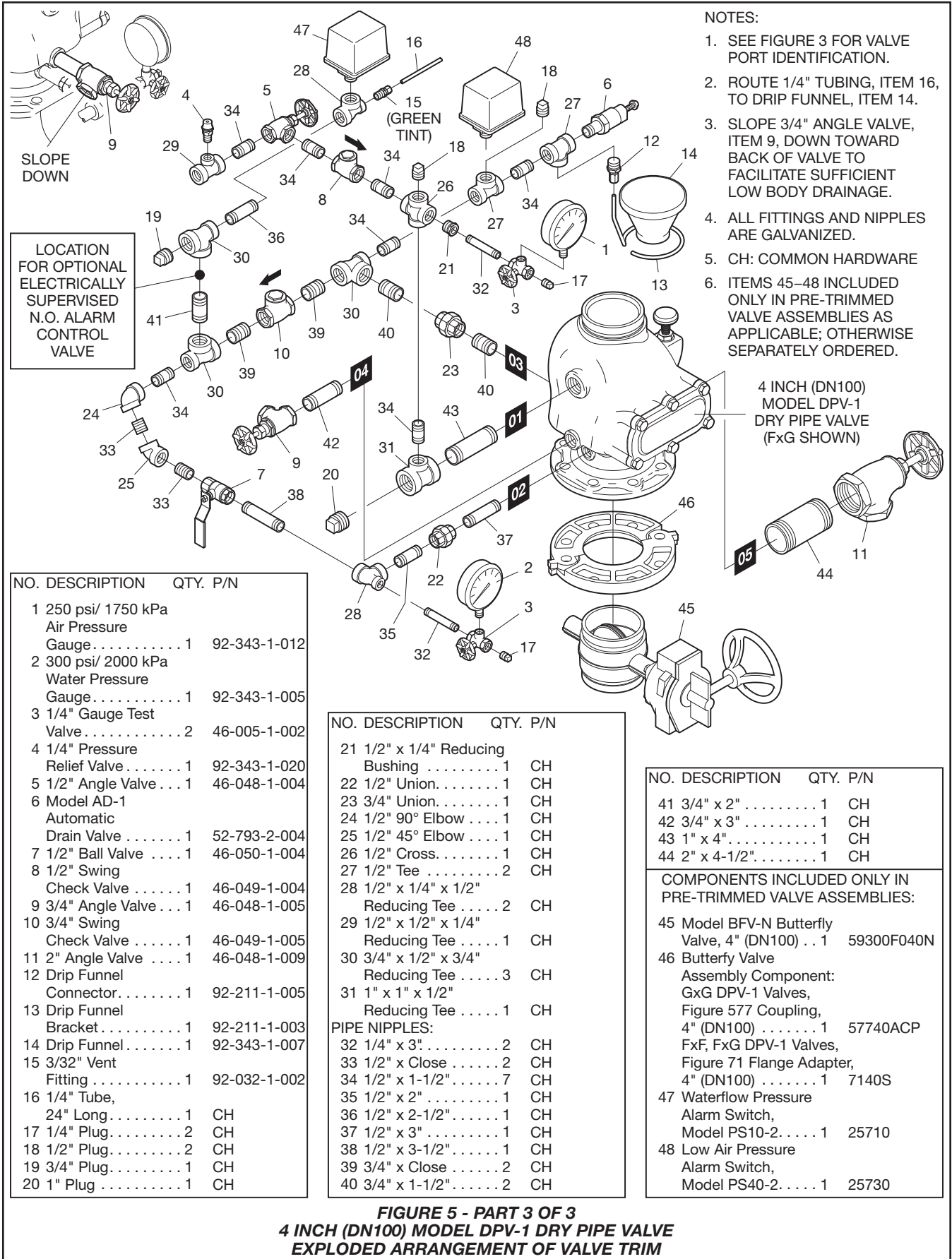

FIGURE 5 - PART 1 OF 3
4 INCH (DN100) MODEL DPV-1 DRY PIPE VALVE
PRE-TRIMMED ASSEMBLY



- NOTES:**
1. INSTALL TRIM ASSEMBLIES IN ALPHABETICAL ORDER.
 2. SEE FIGURE 3 FOR VALVE PORT IDENTIFICATION.
 3. ROUTE 1/4" TUBING TO DRIP FUNNEL.
 4. SLOPE ASSEMBLY B DOWN TOWARD BACK OF VALVE TO FACILITATE SUFFICIENT LOW BODY DRAINAGE.

FIGURE 5 - PART 2 OF 3
4 INCH (DN100) MODEL DPV-1 DRY PIPE VALVE
EXPLODED ARRANGEMENT OF SEMI-ASSEMBLED TRIM



- NOTES:
1. SEE FIGURE 3 FOR VALVE PORT IDENTIFICATION.
 2. ROUTE 1/4" TUBING, ITEM 16, TO DRIP FUNNEL, ITEM 14.
 3. SLOPE 3/4" ANGLE VALVE, ITEM 9, DOWN TOWARD BACK OF VALVE TO FACILITATE SUFFICIENT LOW BODY DRAINAGE.
 4. ALL FITTINGS AND NIPPLES ARE GALVANIZED.
 5. CH: COMMON HARDWARE
 6. ITEMS 45-48 INCLUDED ONLY IN PRE-TRIMMED VALVE ASSEMBLIES AS APPLICABLE; OTHERWISE SEPARATELY ORDERED.

LOCATION FOR OPTIONAL ELECTRICALLY SUPERVISED N.O. ALARM CONTROL VALVE

4 INCH (DN100) MODEL DPV-1 DRY PIPE VALVE (FxF SHOWN)

NO.	DESCRIPTION	QTY.	P/N
1	250 psi/ 1750 kPa Air Pressure Gauge	1	92-343-1-012
2	300 psi/ 2000 kPa Water Pressure Gauge	1	92-343-1-005
3	1/4" Gauge Test Valve	2	46-005-1-002
4	1/4" Pressure Relief Valve	1	92-343-1-020
5	1/2" Angle Valve	1	46-048-1-004
6	Model AD-1 Automatic Drain Valve	1	52-793-2-004
7	1/2" Ball Valve	1	46-050-1-004
8	1/2" Swing Check Valve	1	46-049-1-004
9	3/4" Angle Valve	1	46-048-1-005
10	3/4" Swing Check Valve	1	46-049-1-005
11	2" Angle Valve	1	46-048-1-009
12	Drip Funnel Connector	1	92-211-1-005
13	Drip Funnel Bracket	1	92-211-1-003
14	Drip Funnel	1	92-343-1-007
15	3/32" Vent Fitting	1	92-032-1-002
16	1/4" Tube, 24" Long	1	CH
17	1/4" Plug	2	CH
18	1/2" Plug	2	CH
19	3/4" Plug	1	CH
20	1" Plug	1	CH

NO.	DESCRIPTION	QTY.	P/N
21	1/2" x 1/4" Reducing Bushing	1	CH
22	1/2" Union	1	CH
23	3/4" Union	1	CH
24	1/2" 90° Elbow	1	CH
25	1/2" 45° Elbow	1	CH
26	1/2" Cross	1	CH
27	1/2" Tee	2	CH
28	1/2" x 1/4" x 1/2" Reducing Tee	2	CH
29	1/2" x 1/2" x 1/4" Reducing Tee	1	CH
30	3/4" x 1/2" x 3/4" Reducing Tee	3	CH
31	1" x 1" x 1/2" Reducing Tee	1	CH
PIPE NIPPLES:			
32	1/4" x 3"	2	CH
33	1/2" x Close	2	CH
34	1/2" x 1-1/2"	7	CH
35	1/2" x 2"	1	CH
36	1/2" x 2-1/2"	1	CH
37	1/2" x 3"	1	CH
38	1/2" x 3-1/2"	1	CH
39	3/4" x Close	2	CH
40	3/4" x 1-1/2"	2	CH

NO.	DESCRIPTION	QTY.	P/N
41	3/4" x 2"	1	CH
42	3/4" x 3"	1	CH
43	1" x 4"	1	CH
44	2" x 4-1/2"	1	CH
COMPONENTS INCLUDED ONLY IN PRE-TRIMMED VALVE ASSEMBLIES:			
45	Model BFV-N Butterfly Valve, 4" (DN100)	1	59300F040N
46	Butterfly Valve Assembly Component: GxG DPV-1 Valves, Figure 577 Coupling, 4" (DN100)	1	57740ACP
	FxF, FxG DPV-1 Valves, Figure 71 Flange Adapter, 4" (DN100)	1	7140S
47	Waterflow Pressure Alarm Switch, Model PS10-2	1	25710
48	Low Air Pressure Alarm Switch, Model PS40-2	1	25730

FIGURE 5 - PART 3 OF 3
4 INCH (DN100) MODEL DPV-1 DRY PIPE VALVE
EXPLODED ARRANGEMENT OF VALVE TRIM

NOTES:

1. SEE FIGURE 6 PART 3 FOR TRIM ARRANGEMENT WITH BILL OF MATERIALS AND COMPONENT PART NUMBERS.
2. TRIM SHOWN FULLY ASSEMBLED; COMPONENTS SUCH AS GAUGES AND SWITCHES MAY REQUIRE ASSEMBLY IN TRIM AT INSTALLATION.

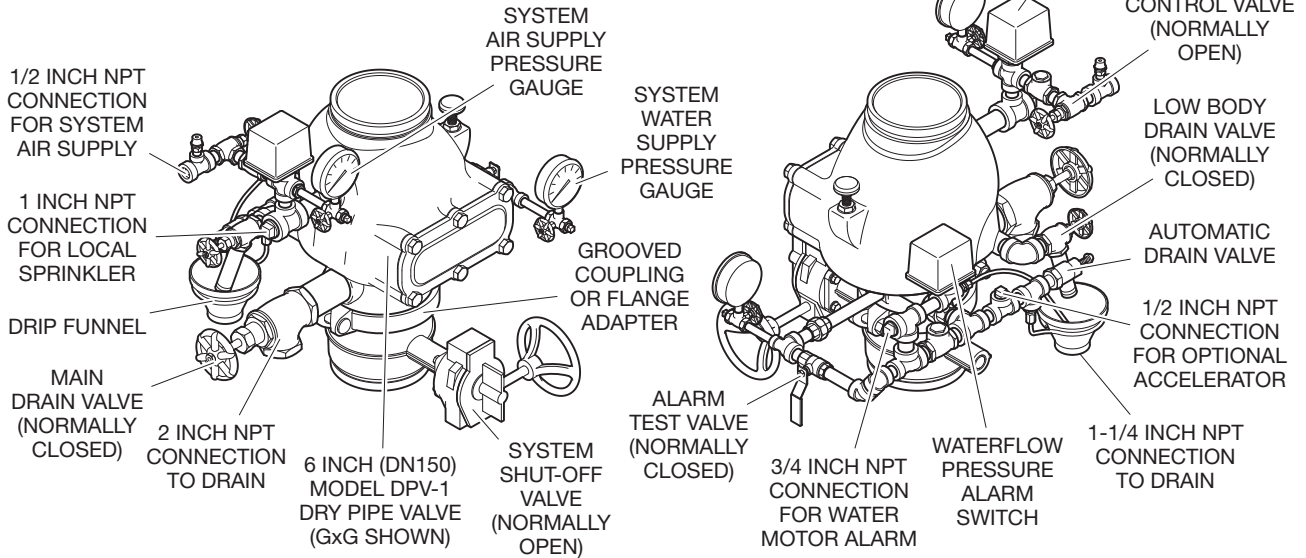

**FIGURE 6 - PART 1 OF 3
6 INCH (DN150) MODEL DPV-1 DRY PIPE VALVE
PRE-TRIMMED ASSEMBLY**

NOTES:

4. SLOPE 3/4" ANGLE VALVE AND 3/4" x 4-1/2" NIPPLE (OF ASSEMBLY B) INTO DRIP FUNNEL TO FACILITATE SUFFICIENT LOW BODY DRAINAGE.

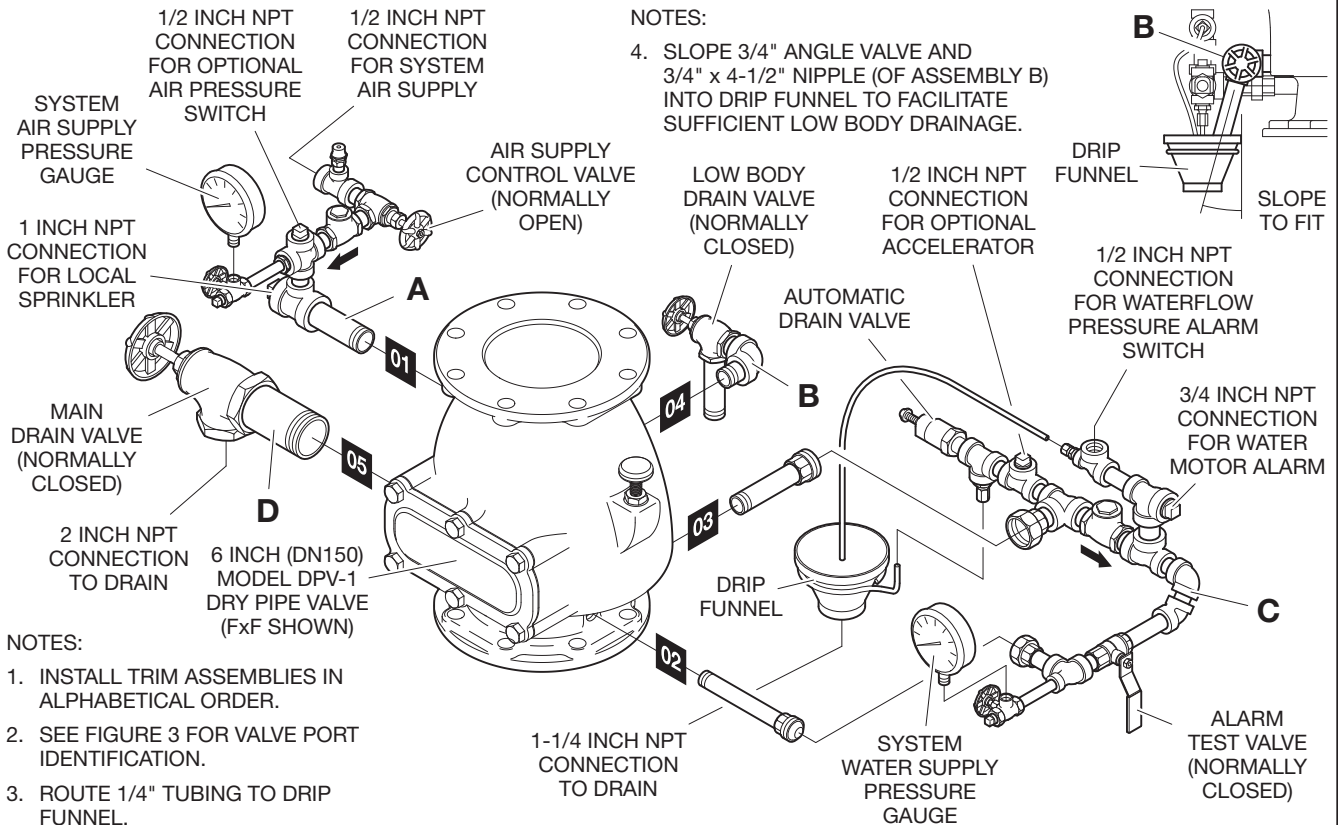

NOTES:

1. INSTALL TRIM ASSEMBLIES IN ALPHABETICAL ORDER.
2. SEE FIGURE 3 FOR VALVE PORT IDENTIFICATION.
3. ROUTE 1/4" TUBING TO DRIP FUNNEL.

**FIGURE 6 - PART 2 OF 3
6 INCH (DN150) MODEL DPV-1 DRY PIPE VALVE
EXPLODED ARRANGEMENT OF SEMI-ASSEMBLED TRIM**

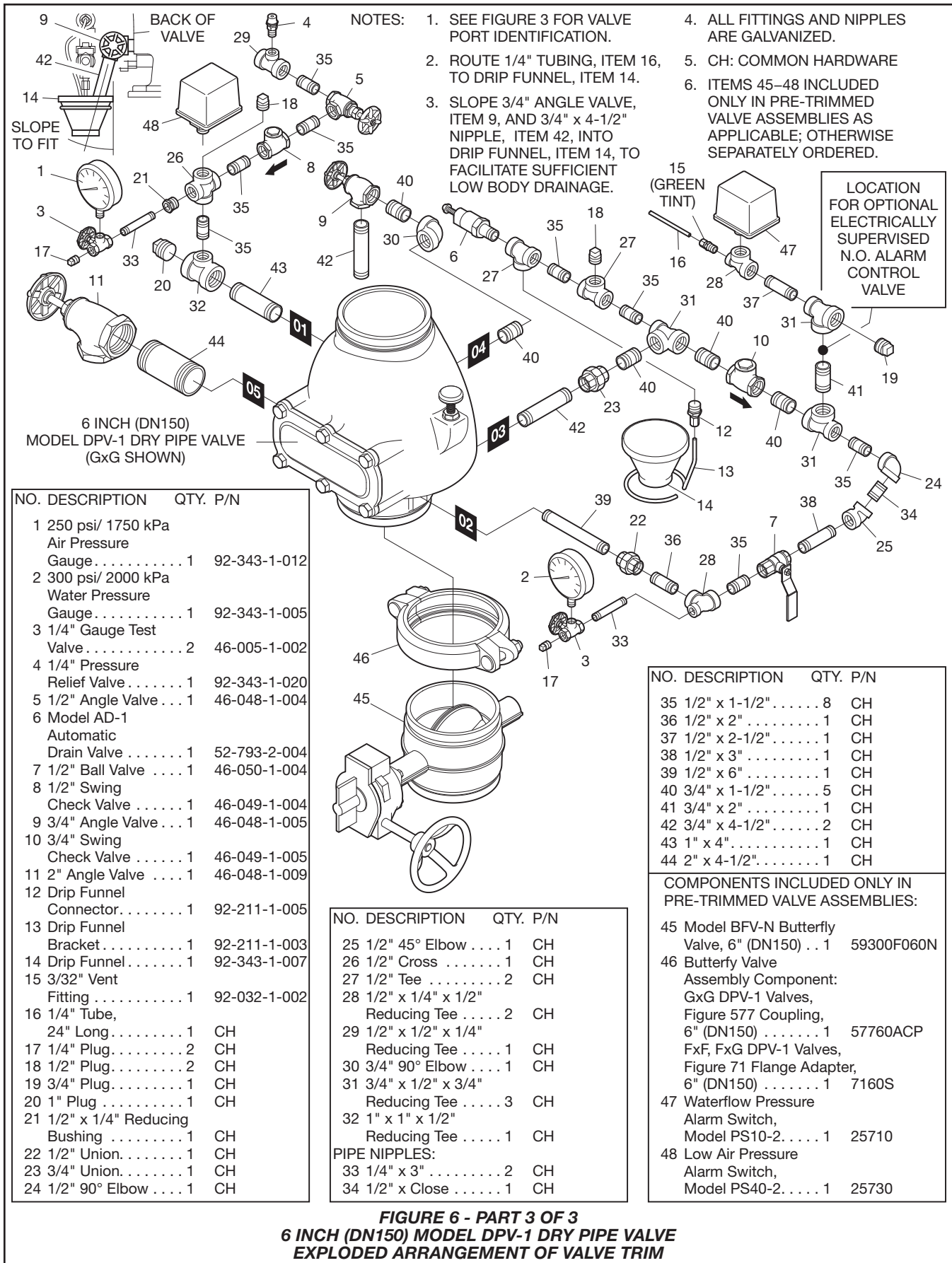

**FIGURE 6 - PART 3 OF 3
6 INCH (DN150) MODEL DPV-1 DRY PIPE VALVE
EXPLODED ARRANGEMENT OF VALVE TRIM**

IMEN DATIS ASIA

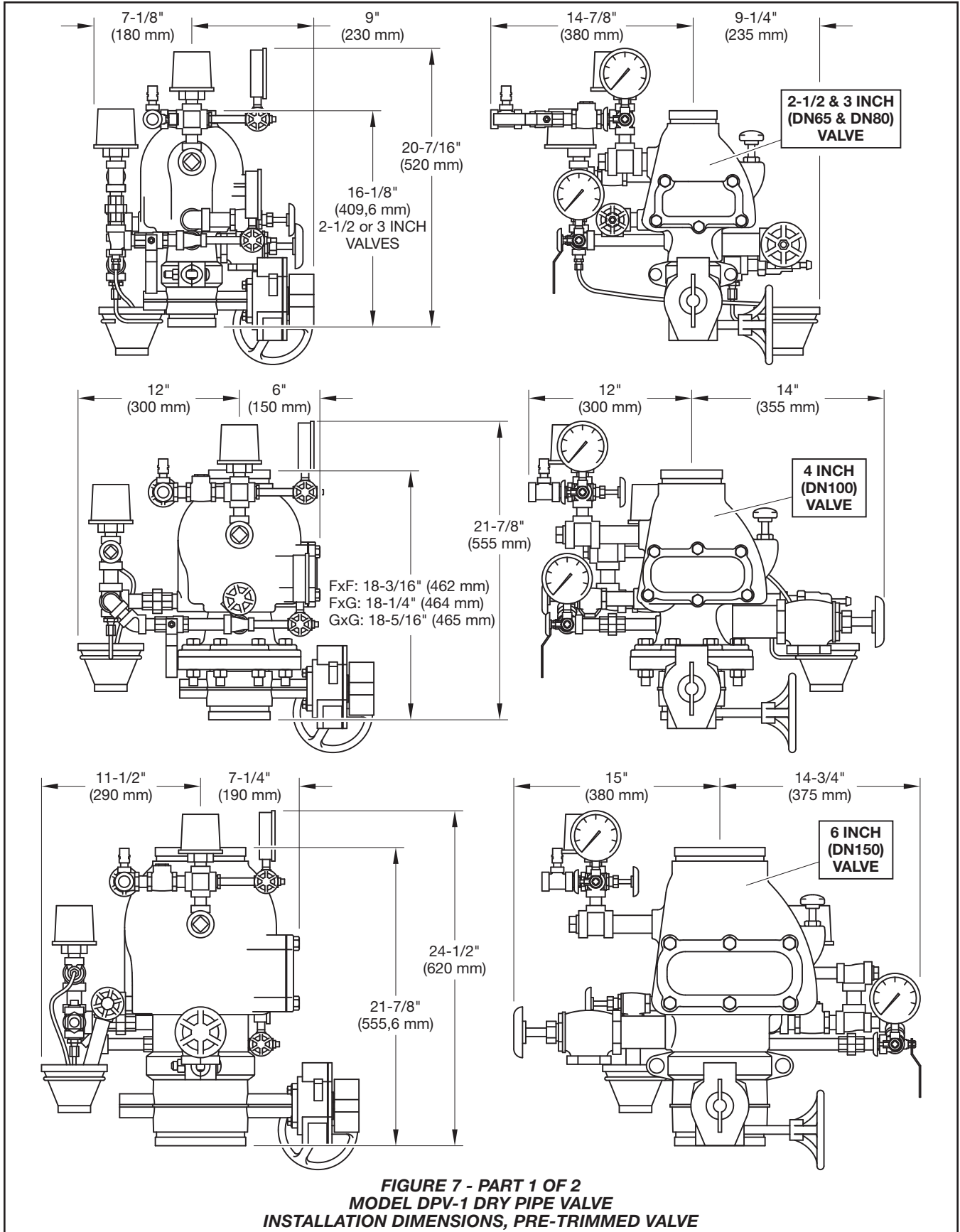

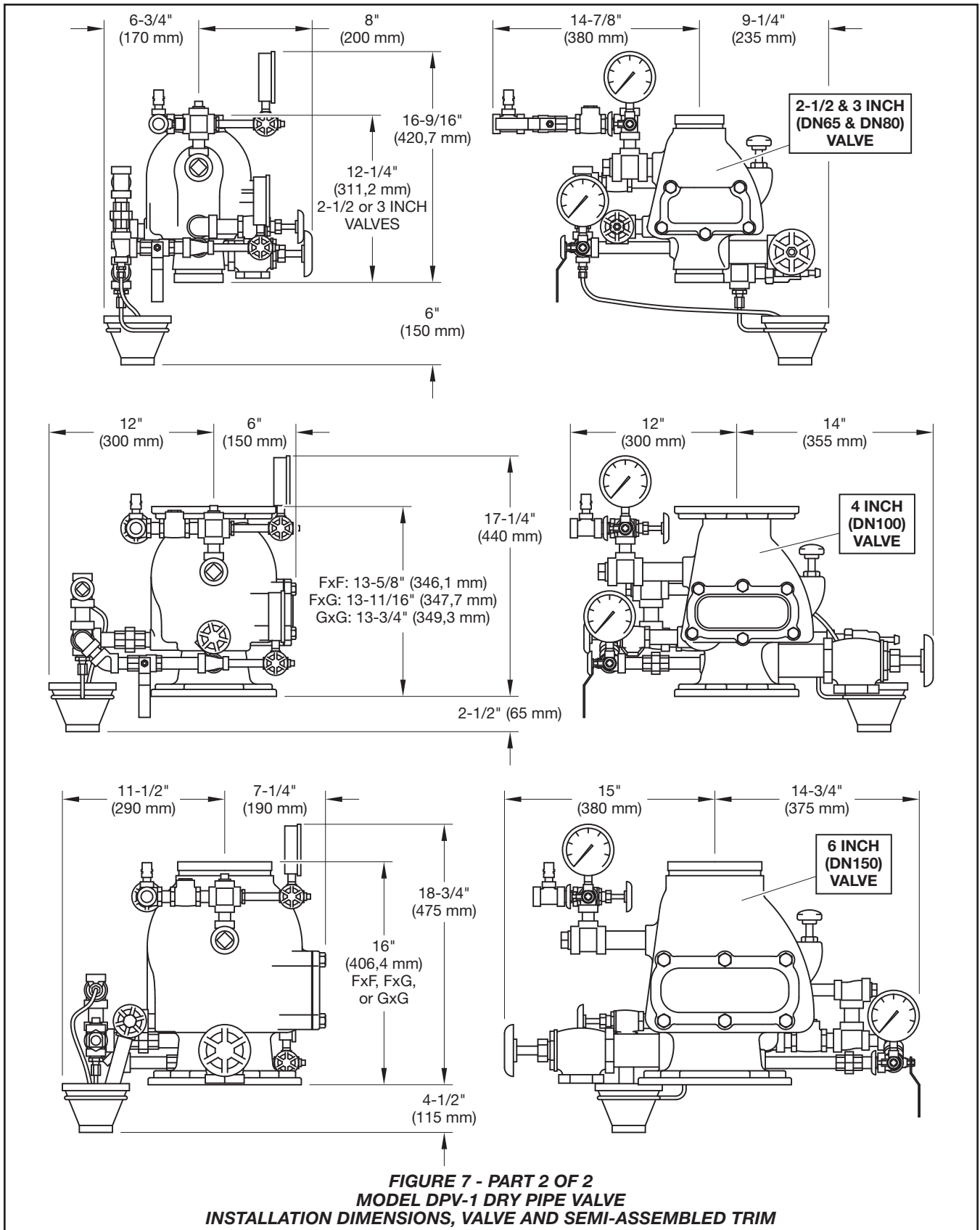

Installation

General Instructions

Proper operation of the Model DPV-1 Dry Pipe Valve depends upon its trim being installed in accordance with the instructions given in this Technical Data Sheet. Failure to follow the appropriate trim diagram may prevent the DPV-1 Valve from functioning properly, as well as void listings, approvals, and the manufacturer's warranties.

Failure to latch open the Clapper Assembly prior to a system hydrostatic test may result in damage to the Clapper Assembly.

The DPV-1 Valve must be installed in a readily visible and accessible location.

The DPV-1 Valve and associated trim must be maintained at a minimum temperature of 40°F (4°C).

Heat tracing of the DPV-1 Valve or its associated trim is not permitted. Heat tracing can result in the formation of hardened mineral deposits that are capable of preventing proper operation.

The Model DPV-1 Dry Pipe Valve is to be installed in accordance with the following criteria:

- All nipples, fittings, and devices must be clean and free of scale and burrs before installation. Use pipe thread sealant sparingly on male pipe threads only.
- The DPV-1 Valve must be trimmed in accordance with Figures 4, 5, or 6, as applicable. If the DPV-1 is to be equipped with a Dry Pipe Valve Accelerator, refer to the Technical Data Sheet TFP1105 for the VIZOR Electronic Dry Pipe Valve Accelerator or TFP1112 for the Model ACC-1 Mechanical Dry Pipe Valve Accelerator.
- Care must be taken to make sure that check valves, strainers, globe valves, etc. are installed with the flow arrows in the proper direction.
- Drain tubing to the drip funnel must be installed with smooth bends that will not restrict flow.
- The main drain and drip funnel drain may be interconnected provided a check valve is located at least 12 inches (300 mm) below the drip funnel. The Low Body Drain Valve (Figure 4, 5, or 6) may be piped so as to discharge into the Drip Funnel or to a separate drain.
- Suitable provision must be made for disposal of drain water. Drainage water must be directed such that it will not cause accidental damage to property or danger to persons.

- Unused pressure alarm switch and/or water motor alarm connections must be plugged.
- The Pressure Relief Valve provided with the Valve Trim is factory set to relieve at a pressure of approximately 45 psi (3,1 bar), which can typically be used for a maximum normal system air pressure of 40 psi (2,8 bar). The Pressure Relief Valve may be reset to a lower or higher pressure; however, it must be reset to relieve at a pressure which is in accordance with the requirements of the authority having jurisdiction.

To reset the Pressure Relief Valve, first loosen the jam nut and then adjust the cap accordingly — clockwise for a higher pressure setting or counter-clockwise for a lower pressure setting. After verifying the desired pressure setting, tighten the jam nut.

- Installation of an Air Maintenance Device, as described in the Technical Data Section, is recommended.
- An Inspector's Test Connection as required By NFPA 13 must be provided on the system piping at the most remote location from the Model DPV-1 Valve.
- Conduit and electrical connections are to be made in accordance with the requirements of the authority having jurisdiction and/or the National Electric Code.
- Before a system hydrostatic test is performed in accordance with NFPA 13 system acceptance test requirements, the Clapper Assembly is to be manually latched open (Ref. Figure 3D); the Automatic Drain Valve (Figure 4, 5, or 6) is to be temporarily replaced with a 1/2 inch NPT plug, the 3/32 inch Vent Fitting (Item 13, Figure 4; Item 15, Figure 5; or Item 15, Figure 6) is to be temporarily replaced with a 1/4 inch NPT plug, and the Handhole Cover Bolts are to be tightened using a cross-draw sequence.

Valve Setting Procedure

Steps 1 through 11 are to be performed when initially setting the Model DPV-1 Dry Pipe Valve; after an operational test of the fire protection system; or, after system operation due to a fire.

NOTES: *If the DPV-1 is equipped with a Dry Pipe Valve Accelerator, refer to its resetting instructions before resetting the DPV-1. Refer to TFP1105 for the VIZOR or TFP1112 for the ACC-1.*

Based on the instructions provided, reset the Accelerator at the appropriate time during the resetting of the DPV-1.

Unless otherwise noted, refer to Figure 4, 5, or 6 to identify functional trim components.

Step 1. Close the Main Control Valve, and close the Air Supply Control Valve. If the DPV-1 is equipped with a Dry Pipe Valve Accelerator, remove the Dry Pipe Valve Accelerator from service in accordance with its Technical Data Sheet (Refer to TFP1105 for the VIZOR or TFP1112 for the ACC-1).

Step 2. Open the Main Drain Valve and all auxiliary drains in the system. Close the auxiliary drain valves after water ceases to discharge. Leave the Main Drain Valve open.

Step 3. Depress the plunger of the Automatic Drain Valve to verify that it is open and that the DPV-1 Valve is completely drained.

Step 4. Open the Optional Alarm Control Valve, as applicable, if it was closed to silence local alarms.

Step 5. As necessary, replace all sprinklers that have operated. Replacement sprinklers must be of the same type and temperature rating as those which have operated.

NOTICE

In order to prevent the possibility of a subsequent operation of an overheated solder type sprinkler, any solder type sprinklers which were possibly exposed to a temperature greater than their maximum rated ambient must be replaced.

Step 6. Push down on the Reset Knob (Figure 3E) to allow the Clapper Assembly to re-seat.

Step 7. Pressurize the system with air (or nitrogen) to 10 psi (0,7 bar), and then individually open all auxiliary drain valves in the system piping to drain any remaining water in trapped sections. Close each drain valve as soon as water ceases to discharge.

Also partially open the Low Body Drain Valve to assure that the riser is completely drained. Close the Low Body Drain Valve as soon as water ceases to discharge.

Step 8. Refer to Table B and then restore the system to the normal system air pressure as necessary to hold the DPV-1 Valve closed.

Step 9. Depress the plunger on the Automatic Drain Valve to make sure it is open and that there is no air discharging.

The absence of air discharging from the Automatic Drain Valve is an indication

of a properly set air seat within the DPV-1 Valve. If air is discharging, refer to the Care and Maintenance section under Automatic Drain Valve Inspection to determine/correct the cause of the leakage problem.

Step 10. Partially open the Main Control Valve. Slowly close the Main Drain Valve as soon as water discharges from the drain connection.

Depress the plunger on the Automatic Drain Valve to make sure that it is open and that there is no water discharging. The absence of water discharging from the Automatic Drain Valve is an indication of a properly set water seat within the DPV-1 Valve. If water is discharging, refer to the Care and Maintenance section under the Automatic Drain Valve Inspection to determine/correct the cause of the leakage problem.

If there are no leaks, the DPV-1 Valve is ready to be placed in service and the Main Control Valve must then be fully opened.

Note: After setting a fire protection system, notify the proper authorities and advise those responsible for monitoring proprietary and/or central station alarms.

Step 11. Once a week after a valve is reset following an operational test or system operation, the Low Body Drain Valve (and any low point drain valves) should be partially opened (and then subsequently closed) to relieve drain-back water. Continue this procedure until drain-back water is no longer present.

Care and Maintenance

The following procedures and inspections should be performed as indicated, in addition to any specific requirements of the NFPA, and any impairment must be immediately corrected.

Before closing a fire protection system main control valve for maintenance work on the fire protection system that it controls, permission to shut down the affected fire protection system must be obtained from the proper authorities and notify all personnel who may be affected by action.

The owner is responsible for the inspection, testing, and maintenance of their fire protection system and devices in compliance with this document, as well as with the applicable standards of the National Fire Protection Association (e.g., NFPA 25), in addition to the standards of any authority having jurisdiction. Contact

the installing contractor or sprinkler manufacturer regarding any questions.

Automatic sprinkler systems are recommended to be inspected, tested, and maintained by a qualified Inspection Service in accordance with local requirements and/or national codes.

The operational test procedure and waterflow pressure alarm test procedure will result in operation of the associated alarms. Consequently, notification must first be given to the owner and the fire department, central station, or other signal station to which the alarms are connected.

Annual Operation Test Procedure

Note: Unless otherwise noted, refer to Figure 4, 5, or 6 to identify functional trim components.

Proper operation of the DPV-1 Valve (i.e., opening of the DPV-1 Valve during a fire condition) should be verified at least once a year as follows:

Step 1. If water must be prevented from flowing beyond the riser, perform the following steps.

- Close the Main Control Valve.
- Open the Main Drain Valve.
- Open the Main Control Valve one turn beyond the position at which water just begins to flow from the Main Drain Valve.
- Close the Main Drain Valve.

Step 2. Open the system's Inspector's Test Connection.

Step 3. Verify that the DPV-1 Valve has operated, as indicated by the flow of water into the system and that all waterflow alarms operate properly.

Step 4. Close the system's Main Control Valve.

Step 5. Reset the DPV-1 Valve in accordance with the Valve Setting Procedure.

Note: It is recommended that the requirement of NFPA 25 to annually inspect the inside of the valve be performed at this time and prior to resetting the DPV-1 Valve. Refer to the Automatic Drain Valve Inspection subsection Steps 2 through 5 for instructions with regard to the inspection of the Clapper Facing.

Quarterly Waterflow Alarm Test Procedure

Testing of the system waterflow alarms should be performed quarterly. To test the waterflow alarm, open the Alarm Test Valve, which will allow a flow of water to the Waterflow Pressure Alarm Switch and/or Water Motor Alarm. Upon satisfactory completion of the test, close the Alarm Test Valve.

Water Pressure Inspection

The Water Pressure Gauge is to be inspected monthly (per NFPA 25) to ensure that normal system water pressure is being maintained.

Air Pressure Inspection

The Air Pressure Gauge is to be inspected monthly (per NFPA 25) to ensure that normal system air pressure is being maintained.

Automatic Drain Valve Inspection

The Automatic Drain Valve should be inspected monthly (per NFPA 25) by depressing the plunger and checking to ensure that the Automatic Drain Valve is not discharging water and/or air. A discharge of water and/or air is an indication that the air and/or water seats are leaking, which could subsequently cause a false operation should the intermediate chamber become inadvertently pressurized.

If leakage is present, take the DPV-1 Valve out of service (i.e., close the main control valve, open the main drain valve, close the air supply control valve, remove the Dry Pipe Valve Accelerator from service, as applicable, in accordance with its Technical Data Sheet (Refer to TFP1105 for the VIZOR or TFP1112 for the ACC-1), and open the Inspector's Test Connection to relieve the system air pressure to 0 psig as indicated on the System Air Pressure Gauge), and then after removing the Handhole Cover, perform the following steps:

Step 1. Make sure that the Seat Ring is clean and free of any nicks or significant scratches.

Step 2. Remove the Clapper Assembly from the valve by first pulling out the Hinge Pin.

Step 3. Disassemble the Clapper Facing Retainer from the Clapper so that the Clapper Facing can be removed and inspected. Make sure that the Clapper Facing does not show signs of compression set, damage, etc. Replace the Clapper Facing if there is any signs of wear.

Step 4. Clean the Clapper Facing, Clapper, and Clapper Facing Retainer, and then reassemble the Clapper Assembly.

Step 5. Reinstall the Clapper Assembly with its Hinge Pin and then reinstall the Handhole Cover.

Limited Warranty

For warranty terms and conditions, visit www.tyco-fire.com.

Ordering Procedure

Refer to Table A for Flange Drilling Specifications.

Standard DPV-1 Dry Pipe Valve (American Standard Flange Drilling, Threaded Ports, and Groove Outside Diameter, as applicable)

Specify: (specify size) Model DPV-1 Dry Pipe Valve with (specify Inlet x Outlet) end connections, P/N (specify).

2-1/2 Inch (DN65)

GxG,
2.88 inch (73,1 mm) O.D.
Groove x 2.88 inch (73,1 mm)
O.D. Groove P/N 52-310-1-925

3 Inch (DN80)

GxG,
3.50 inch (88,9 mm) O.D.
Groove x 3.50 inch (88,9 mm)
O.D. Groove P/N 52-310-1-930

4 Inch (DN100)

GxG,
4.50 inch (114,3 mm) O.D.
Groove x 4.50 inch (114,3 mm)
O.D. Groove P/N 52-310-1-940

FxG,

ANSI Drilled Flange
x 4.50 inch (114,3 mm)
O.D. Groove P/N 52-310-1-440

FxF,

ANSI Drilled Flange x ANSI
Drilled Flanged P/N 52-310-1-040

6 Inch (DN150)

GxG,
6.62 inch (168,3 mm) O.D.
Groove x 6.62 inch (168,3 mm)
O.D. Groove P/N 52-310-1-960

FxG,

ANSI Drilled Flange
x 6.62 inch (168,3 mm)
O.D. Groove P/N 52-310-1-460

FxF,

ANSI Drilled Flange x ANSI
Drilled Flanged P/N 52-310-1-060

Pre-Trimmed DPV-1 Assemblies with Butterfly Valve

Specify: 2-1/2 Inch DPV-1 Pre-Trimmed Valve Assembly, P/N 52-310-3-925

Specify: 3 Inch DPV-1 Pre-Trimmed Valve Assembly, P/N 52-310-3-930

Specify: 4 Inch DPV-1 Pre-Trimmed Valve Assembly, P/N (specify)

FxF P/N 52-310-3-040
FxG P/N 52-310-3-440
GxG P/N 52-310-3-940

Specify: 6 Inch DPV-1 Pre-Trimmed Valve Assembly, P/N (specify)

FxF P/N 52-310-3-060
FxG P/N 52-310-3-460
GxG P/N 52-310-3-960

Pre-Trimmed DPV-1 Assemblies without Butterfly Valve

Specify: 4 Inch DVP-1 Pre-Trimmed Valve Assembly without Butterfly, P/N (specify)

FxF P/N 52-310-4-040
FxG P/N 52-310-4-440

Specify: 6 Inch DVP-1 Pre-Trimmed Valve Assembly without Butterfly, P/N (specify)

FxF P/N 52-310-4-060
FxG P/N 52-310-4-460

Standard Galvanized Semi-Assembled DPV-1 Trim

Specify: 2-1/2 and 3 Inch DPV-1 Semi-Assembled Galvanized Trim, P/N 52-309-2-005.

Specify: 4 Inch DPV-1 Semi-Assembled Galvanized Trim, P/N 52-309-2-001

Specify: 6 Inch DPV-1 Semi-Assembled Galvanized Trim, P/N 52-309-2-002

Optional Accelerator VIZOR Electronic Dry Pipe Accelerator (with Trim) (Details provided in TFP1105)

Specify: VIZOR Electronic Dry Pipe Accelerator for use with the 4 or 6 inch TYCO Model DPV-1 Dry Pipe Valve trim, P/N 52-312-3-001

Model ACC-1 Mechanical Accelerator (Details provided in TFP1112)

Specify: Model ACC-1 Dry Pipe Accelerator, P/N 52-311-1-001, and

Galvanized Accelerator Trim for Model DPV-1 Dry Pipe Valve, P/N 52-311-2-010

Optional 600 PSI Water Pressure Gauge

Specify: 600 PSI Water Pressure Gauge, P/N 92-343-1-004

Accessories

Order the Technical Data Sheets for the following, as applicable, for details and additional accessories:

Model PS10-2
Potter Electric Waterflow
Pressure Alarm Switch
. P/N 25710

Model PS40-2
Potter Electric Low Air Pressure Alarm
Switch P/N 25730

Model WMA-1
Water Motor Alarm
. P/N 52-630-1-001

Model AMD-1
Air Maintenance Device
. P/N 52-324-2-002

Model AMD-2
Air Maintenance Device
. P/N 52-326-2-001

Model AMD-3
Nitrogen Maintenance Device
. P/N 52-328-2-001

Replacement Valve Parts

Specify: (description) for use with (specify size) Model DPV-1 Dry Pipe Valve, P/N (see Figure 1 Parts 1 and 2 as applicable).

Replacement Trim Parts

Specify: (description) for use with (specify size) Model DPV-1 Dry Pipe Valve, P/N (Figures 4, 5, or 6, Part 3 as applicable).

Weights

The following are the nominal weights for the valves and trim:

Pre-Trimmed DPV-1 Valve Assemblies:

2-1/2 Inch (DN65)
GxG Dry Pipe Valve. 87lbs.(40kg)

3 Inch (DN80)
GxG Dry Pipe Valve 90lbs.(42kg)

4 Inch (DN100)
GxG Dry Pipe Valve 121lbs.(56kg)

4 Inch (DN100)
FxG Dry Pipe Valve. 135lbs.(64kg)

4 Inch (DN100)
FxF Dry Pipe Valve 145lbs.(69kg)

6 Inch (DN150)
GxG Dry Pipe Valve 175lbs.(81kg)

6 Inch (DN150)
FxG Dry Pipe Valve. 195lbs. (90kg)

6 Inch (DN150)
FxF Dry Pipe Valve 208lbs. (96kg)

Standard Galvanized Semi-Assembled DPV-1 Trim:

2-1/2 Inch (DN65)
Valve Trim 23lbs. (11kg)

3 Inch (DN80)
Valve Trim 23lbs. (11kg)

4 Inch (DN100)
Valve Trim 30lbs. (14kg)

6 Inch (DN150)
Valve Trim 30lbs. (14kg)

DPV-1 Valve:

- 2-1/2 Inch (DN65)
 - GxG Dry Pipe Valve 37lbs. (17kg)
- 3 Inch (DN80)
 - GxG Dry Pipe Valve 38lbs. (18kg)
- 4 Inch (DN100)
 - GxG Dry Pipe Valve 57lbs. (26kg)
- 4 Inch (DN100)
 - FxG Dry Pipe Valve. 67lbs. (31kg)
- 4 Inch (DN100)
 - FxF Dry Pipe Valve 77lbs. (36kg)
- 6 Inch (DN150)
 - GxG Dry Pipe Valve 95lbs. (44kg)
- 6 Inch (DN150)
 - FxG Dry Pipe Valve. 108 lbs. (50kg)
- 6 Inch (DN150)
 - FxF Dry Pipe Valve 121lbs. (56kg)

Other DPV-1 Dry Pipe Valves

Notes: Other DPV-1 Dry Pipe Valves are valves ordered with a any combination of flange, threaded ports, or groove outside diameter not offered under "Standard DPV-1 Dry Pipe Valve" offerings.

Valves with NPT threaded ports are intended for use with the "Standard Galvanized Semi-Assembled DPV-1 Valve Trim" offered and detailed in this document. Valves with ISO threaded ports are intended for use with special order trim that is provided by local distributors to meet the specific needs of certain localities. Please contact your local distributor regarding valves and valve trim for specific localities.

Specify: (specify size) Model DPV-1 Dry Pipe Valve with (specify inlet x outlet) connections with (specify NPT or ISO) threaded ports, P/N (specify).

Part Numbers For Other 2-1/2 Inch (DN65) Dry Pipe Valves

- Valves with NPT Ports**
- GxG,
 - 3.00"(76,1 mm) Outside Dia.
 - Groove x 3.00" (76,1 mm)
 - Outside Dia. Groove
 - P/N 52-309-1-930

Valves with ISO Ports

- GxG,
 - 2.88"(73,0 mm) Outside Dia.
 - Groove x 2.88" (73,0 mm)
 - Outside Dia. Groove
 - P/N 52-309-1-920

- GxG,
 - 3.00"(76,1 mm) Outside Dia.
 - Groove x 3.00" (76,1 mm)
 - Outside Dia. Groove
 - P/N 52-309-1-940

Part Numbers For Other 3 Inch (DN80) Dry Pipe Valves

- Valves with ISO Ports**
- GxG,
 - 3.50"(88,9 mm) Outside Dia.
 - Groove x 3.50" (88,9 mm)
 - Outside Dia. Groove
 - P/N 52-309-1-922

Part Numbers For Other 4 Inch (DN100) Dry Pipe Valves

- Valves with NPT Ports**
- FxG,
 - ISO Flange x 4.50" (114,3 mm)
 - Outside Dia. Groove
 - P/N 52-309-1-253
 - FxG,
 - AS Flange x 4.50" (114,3 mm)
 - Outside Dia. Groove
 - P/N 52-309-1-613
 - FxG,
 - JIS Flange x 4.50" (114,3 mm)
 - Outside Dia. Groove
 - P/N 52-309-1-813
 - FxF,
 - ISO Flange x ISO Flange
 - P/N 52-309-1-133
 - FxF,
 - AS Flange x AS Flange
 - P/N 52-309-1-513
 - FxF,
 - JIS Flange x JIS Flange
 - P/N 52-309-1-713

Valves with ISO Ports

- GxG,
 - 4.50"(114,3 mm) Outside Dia.
 - Groove x 4.50" (114,3 mm)
 - Outside Dia. Groove
 - P/N 52-309-1-923
- FxG,
 - ISO Flange x 4.50" (114,3 mm)
 - Outside Dia. Groove
 - P/N 52-309-1-213
- FxF,
 - ISO Flange x ISO Flange
 - P/N 52-309-1-113

Part Numbers For Other 6 Inch (DN150) Dry Pipe Valves

- Valves with NPT Ports**
- GxG,
 - 6.50"(165,1 mm) Outside Dia.
 - Groove x 6.50" (165,1 mm)
 - Outside Dia. Groove
 - P/N 52-309-1-935
 - FxG,
 - ANSI Flange x 6.50" (165,1 mm)
 - Outside Dia. Groove
 - P/N 52-309-1-435
 - FxG,
 - ISO Flange x 6.62" (168,3 mm)
 - Outside Dia. Groove
 - P/N 52-309-1-255
 - FxG,
 - ISO Flange x 6.50" (165,1 mm)
 - Outside Dia. Groove
 - P/N 52-309-1-335
 - FxG,
 - AS Flange x 6.62" (168,3 mm)
 - Outside Dia. Groove
 - P/N 52-309-1-615
 - FxG,
 - AS Flange x 6.50" (165,1 mm)
 - Outside Dia. Groove
 - P/N 52-309-1-635

- FxG,
 - JIS Flange x 6.62" (168,3 mm)
 - Outside Dia. Groove
 - P/N 52-309-1-815
- FxG,
 - JIS Flange x 6.50" (165,1 mm)
 - Outside Dia. Groove
 - P/N 52-309-1-835
- FxF,
 - ISO Flange x ISO Flange
 - P/N 52-309-1-135
- FxF,
 - AS Flange x AS Flange
 - P/N 52-309-1-515
- FxF,
 - JIS Flange x JIS Flange
 - P/N 52-309-1-715

Valves with ISO Ports

- GxG,
 - 6.62"(168,3 mm) Outside Dia.
 - Groove x 6.62"(168,3 mm)
 - Outside Dia. Groove
 - P/N 52-309-1-925
- GxG,
 - 6.50"(165,1 mm) Outside Dia.
 - Groove x 6.50"(165,1 mm)
 - Outside Dia. Groove
 - P/N 52-309-1-945
- FxG,
 - ISO Flange x 6.62"(168,3 mm)
 - Outside Dia. Groove
 - P/N 52-309-1-215
- FxG,
 - ISO Flange x 6.50"(165,1 mm)
 - Outside Dia. Groove
 - P/N 52-309-1-315
- FxF,
 - ISO Flange x ISO Flange
 - P/N 52-309-1-115