

**NFPA<sup>®</sup>**

# 76

---

Standard for the  
Fire Protection of  
Telecommunications Facilities

---

**2020**



## IMPORTANT NOTICES AND DISCLAIMERS CONCERNING NFPA® STANDARDS

NFPA® codes, standards, recommended practices, and guides (“NFPA Standards”), of which the document contained herein is one, are developed through a consensus standards development process approved by the American National Standards Institute. This process brings together volunteers representing varied viewpoints and interests to achieve consensus on fire and other safety issues. While the NFPA administers the process and establishes rules to promote fairness in the development of consensus, it does not independently test, evaluate, or verify the accuracy of any information or the soundness of any judgments contained in NFPA Standards.

The NFPA disclaims liability for any personal injury, property, or other damages of any nature whatsoever, whether special, indirect, consequential or compensatory, directly or indirectly resulting from the publication, use of, or reliance on NFPA Standards. The NFPA also makes no guaranty or warranty as to the accuracy or completeness of any information published herein.

In issuing and making NFPA Standards available, the NFPA is not undertaking to render professional or other services for or on behalf of any person or entity. Nor is the NFPA undertaking to perform any duty owed by any person or entity to someone else. Anyone using this document should rely on his or her own independent judgment or, as appropriate, seek the advice of a competent professional in determining the exercise of reasonable care in any given circumstances.

The NFPA has no power, nor does it undertake, to police or enforce compliance with the contents of NFPA Standards. Nor does the NFPA list, certify, test, or inspect products, designs, or installations for compliance with this document. Any certification or other statement of compliance with the requirements of this document shall not be attributable to the NFPA and is solely the responsibility of the certifier or maker of the statement.

### REVISION SYMBOLS IDENTIFYING CHANGES FROM THE PREVIOUS EDITION

Text revisions are shaded. A **Δ** before a section number indicates that words within that section were deleted and a **Δ** to the left of a table or figure number indicates a revision to an existing table or figure. When a chapter was heavily revised, the entire chapter is marked throughout with the **Δ** symbol. Where one or more sections were deleted, a **•** is placed between the remaining sections. Chapters, annexes, sections, figures, and tables that are new are indicated with an **N**.

Note that these indicators are a guide. Rearrangement of sections may not be captured in the markup, but users can view complete revision details in the First and Second Draft Reports located in the archived revision information section of each code at [www.nfpa.org/docinfo](http://www.nfpa.org/docinfo). Any subsequent changes from the NFPA Technical Meeting, Tentative Interim Amendments, and Errata are also located there.

### REMINDER: UPDATING OF NFPA STANDARDS

Users of NFPA codes, standards, recommended practices, and guides (“NFPA Standards”) should be aware that these documents may be superseded at any time by the issuance of a new edition, may be amended with the issuance of Tentative Interim Amendments (TIAs), or be corrected by Errata. It is intended that through regular revisions and amendments, participants in the NFPA standards development process consider the then-current and available information on incidents, materials, technologies, innovations, and methods as these develop over time and that NFPA Standards reflect this consideration. Therefore, any previous edition of this document no longer represents the current NFPA Standard on the subject matter addressed. NFPA encourages the use of the most current edition of any NFPA Standard [as it may be amended by TIA(s) or Errata] to take advantage of current experience and understanding. An official NFPA Standard at any point in time consists of the current edition of the document, including any issued TIAs and Errata then in effect.

To determine whether an NFPA Standard has been amended through the issuance of TIAs or corrected by Errata, visit the “Codes & Standards” section at [www.nfpa.org](http://www.nfpa.org).

# **ADDITIONAL IMPORTANT NOTICES AND DISCLAIMERS CONCERNING NFPA® STANDARDS**

## **Updating of NFPA Standards**

Users of NFPA codes, standards, recommended practices, and guides (“NFPA Standards”) should be aware that these documents may be superseded at any time by the issuance of a new edition, may be amended with the issuance of Tentative Interim Amendments (TIAs), or be corrected by Errata. It is intended that through regular revisions and amendments, participants in the NFPA standards development process consider the then-current and available information on incidents, materials, technologies, innovations, and methods as these develop over time and that NFPA Standards reflect this consideration. Therefore, any previous edition of this document no longer represents the current NFPA Standard on the subject matter addressed. NFPA encourages the use of the most current edition of any NFPA Standard [as it may be amended by TIA(s) or Errata] to take advantage of current experience and understanding. An official NFPA Standard at any point in time consists of the current edition of the document, including any issued TIAs and Errata then in effect.

To determine whether an NFPA Standard has been amended through the issuance of TIAs or corrected by Errata, visit the “Codes & Standards” section at [www.nfpa.org](http://www.nfpa.org).

## **Interpretations of NFPA Standards**

A statement, written or oral, that is not processed in accordance with Section 6 of the Regulations Governing the Development of NFPA Standards shall not be considered the official position of NFPA or any of its Committees and shall not be considered to be, nor be relied upon as, a Formal Interpretation.

## **Patents**

The NFPA does not take any position with respect to the validity of any patent rights referenced in, related to, or asserted in connection with an NFPA Standard. The users of NFPA Standards bear the sole responsibility for determining the validity of any such patent rights, as well as the risk of infringement of such rights, and the NFPA disclaims liability for the infringement of any patent resulting from the use of or reliance on NFPA Standards.

NFPA adheres to the policy of the American National Standards Institute (ANSI) regarding the inclusion of patents in American National Standards (“the ANSI Patent Policy”), and hereby gives the following notice pursuant to that policy:

NOTICE: The user’s attention is called to the possibility that compliance with an NFPA Standard may require use of an invention covered by patent rights. NFPA takes no position as to the validity of any such patent rights or as to whether such patent rights constitute or include essential patent claims under the ANSI Patent Policy. If, in connection with the ANSI Patent Policy, a patent holder has filed a statement of willingness to grant licenses under these rights on reasonable and nondiscriminatory terms and conditions to applicants desiring to obtain such a license, copies of such filed statements can be obtained, on request, from NFPA. For further information, contact the NFPA at the address listed below.

## **Law and Regulations**

Users of NFPA Standards should consult applicable federal, state, and local laws and regulations. NFPA does not, by the publication of its codes, standards, recommended practices, and guides, intend to urge action that is not in compliance with applicable laws, and these documents may not be construed as doing so.

## **Copyrights**

NFPA Standards are copyrighted. They are made available for a wide variety of both public and private uses. These include both use, by reference, in laws and regulations, and use in private self-regulation, standardization, and the promotion of safe practices and methods. By making these documents available for use and adoption by public authorities and private users, the NFPA does not waive any rights in copyright to these documents.

Use of NFPA Standards for regulatory purposes should be accomplished through adoption by reference. The term “adoption by reference” means the citing of title, edition, and publishing information only. Any deletions, additions, and changes desired by the adopting authority should be noted separately in the adopting instrument. In order to assist NFPA in following the uses made of its documents, adopting authorities are requested to notify the NFPA (Attention: Secretary, Standards Council) in writing of such use. For technical assistance and questions concerning adoption of NFPA Standards, contact NFPA at the address below.

## **For Further Information**

All questions or other communications relating to NFPA Standards and all requests for information on NFPA procedures governing its codes and standards development process, including information on the procedures for requesting Formal Interpretations, for proposing Tentative Interim Amendments, and for proposing revisions to NFPA standards during regular revision cycles, should be sent to NFPA headquarters, addressed to the attention of the Secretary, Standards Council, NFPA, 1 Batterymarch Park, P.O. Box 9101, Quincy, MA 02269-9101; email: [stds\\_admin@nfpa.org](mailto:stds_admin@nfpa.org).

For more information about NFPA, visit the NFPA website at [www.nfpa.org](http://www.nfpa.org). All NFPA codes and standards can be viewed at no cost at [www.nfpa.org/docinfo](http://www.nfpa.org/docinfo).

Copyright © 2019 National Fire Protection Association®. All Rights Reserved.

## NFPA® 76

### Standard for the

# Fire Protection of Telecommunications Facilities

## 2020 Edition

This edition of NFPA 76, *Standard for the Fire Protection of Telecommunications Facilities*, was prepared by the Technical Committee on Telecommunications. It was issued by the Standards Council on November 4, 2019, with an effective date of November 24, 2019, and supersedes all previous editions.

This edition of NFPA 76 was approved as an American National Standard on November 24, 2019.

### Origin and Development of NFPA 76

In April 1996, the NFPA Standards Council approved a new committee project to develop documents on fire protection for telecommunications networks. The Technical Committee on Telecommunications focused on network reliability of public telecommunications. The committee was responsive to fire protection challenges identified by the Network Reliability Council, which was sponsored by the Federal Communications Commission (FCC).

The first edition of NFPA 76, *Recommended Practice for the Fire Protection of Telecommunications Facilities*, published in 2002, was created to be used as a performance-based document in the format established by NFPA for performance documents.

The document was changed from a recommended practice to a standard for the 2005 edition. Requirements for large and small telecommunications facilities were combined into one chapter. A chapter was added for redundant-based or replacement-based approaches.

For the 2009 edition, the standard was edited to improve the language and clarify the technical committee's intent. Sections were revised to reflect changes to the signal-processing equipment areas. In addition, the requirements for early warning fire detection and very early warning fire detection were updated.

The 2012 edition featured a new section on aisle containment systems for telecommunications equipment and how these systems must be assessed for their interaction with fire protection features. Revisions were made to make the requirements of the standard easier to enforce. A number of definitions were extracted from *NFPA 70, National Electrical Code*, to define terms used in the body of the standard that were not defined in previous editions.

The 2016 edition included language that clarified and emphasized the intent of the standard as it applies to existing and altered facilities retroactively. A new chapter on small unoccupied structures, which were had been excluded from the scope of this standard, was added. The new chapter provided the minimum requirements to be applied to such structures.

The 2020 edition of the standard includes clarification of battery terminology. Flooded lead-acid and flooded NiCd batteries are now called *vented lead-acid* and *vented NiCd* batteries. The term *lithium* was changed to *lithium-ion* throughout the document to specify a type of lithium battery. Spill control requirements for sodium nickel batteries was deleted; these batteries do not need spill control because of the battery chemistry. The term *smoke detectors* was changed to *spot-type smoke detectors* to refer to a type of smoke detector that is discussed in the requirements and does not apply to other types of smoke detectors.

## Technical Committee on Telecommunications

**Steve C. Dryden**, *Chair*  
Henderson Engineers, GA [SE]

**Robert G. Backstrom**, UL LLC, IL [RT]

**Leonard Belliveau, Jr.**, JENSEN HUGHES, MA [SE]

**Jeffrey A. Betz**, AT&T Corporation, NJ [U]

**Michael J. Bosma**, The Viking Corporation, MI [M]  
Rep. National Fire Sprinkler Association

**Shaun A. Brasseau**, Liberty Mutual Property, PA [I]

**Shane M. Clary**, Bay Alarm Company, CA [M]  
Rep. Automatic Fire Alarm Association, Inc.

**Daniel A. Dahl**, Morrison Hershfield Corporation, GA [SE]

**Mickey L. Driggers**, CenturyLink, CO [U]

**Robert P. Gardner**, Global Risk Consultants, KS [SE]

**Kirk W. Humbrecht**, Phoenix Fire Systems, Inc., IL [M]  
Rep. Fire Suppression Systems Association

**Jonathan G. Ingram**, UTC/Kidde-Fenwal, Inc., MA [M]

**Robert Kasiski**, FM Global, MA [I]

**Stanley Kaufman**, CableSafe, Inc./OFS, GA [M]  
Rep. Plastics Industry Association (Plastics)

**Richard G. Kluge**, Ericsson, NJ [U]

Rep. Alliance for Telecommunications Industry Solutions

**Scott R. Lang**, Honeywell International, IL [M]

Rep. National Electrical Manufacturers Association

**Chad Mariska**, APS FireCo, OK [IM]

Rep. National Association of Fire Equipment Distributors

**Thomas F. Norton**, Norel Service Company, Inc., MA [IM]

**Ronald D. Ouimette**, Siemens Building Technologies, Inc., NJ [M]

**Trey Pitts**, Sprint, KS [C]

**Brad Pradel**, American International Group, TX [I]

**Rodger Reiswig**, Johnson Controls, FL [M]

**Buddy Rice**, Deer Park Fire Marshals Office, TX [E]

**Mark C. Smith**, 3M Company, IL [M]

**Ronald A. Stein**, Aon Global Risk Consultants, MO [I]

### Alternates

**Jon R. Ackley**, Dalmatian Fire, IN [M]  
(Alt. to Michael J. Bosma)

**Wayne J. Aho, Jr.**, Johnson Controls, MA [M]  
(Alt. to Rodger Reiswig)

**Edward G. Bond, Jr.**, Centurylink, NC [U]  
(Alt. to Mickey L. Driggers)

**Sheila C. DeMand**, Aon, MO [I]  
(Alt. to Ronald A. Stein)

**Richard Ffrench**, FM Global, RI [I]  
(Alt. to Robert Kasiski)

**Daniel P. Finnegan**, Siemens Industry, Inc., IL [M]  
(Alt. to Ronald D. Ouimette)

**William D. Johnson**, Mid State Fire Equipment Inc., FL [IM]  
(Alt. to Chad Mariska)

**Steven W. Joseph**, Honeywell/Xtralis, Inc., OR [M]  
(Alt. to Scott R. Lang)

**Gerard Kolkmeier**, AT&T, NY [U]  
(Alt. to Jeffrey A. Betz)

**Daniel Dean Lloyd**, Munich Re/Hartford Steam Boiler, TX [I]  
(Voting Alt.)

**Mark W. Lund**, 3M Company, MN [M]  
(Alt. to Mark C. Smith)

**Bryan Edwin Matthews**, Liberty Mutual Group, NY [I]  
(Alt. to Shaun A. Brasseau)

**Paul R. Nelson**, Orr Protection Systems, Inc., KY [M]  
(Alt. to Kirk W. Humbrecht)

**Daniel J. O'Connor**, JENSEN HUGHES, IL [SE]  
(Alt. to Leonard Belliveau, Jr.)

**Randy H. Schubert**, Ericsson, NJ [U]  
(Alt. to Richard G. Kluge)

### Nonvoting

**Thomas G. Cleary**, National Institute of Standards & Technology  
(NIST), MD [RT]

**Shmuel Netanel**, Eidan Safety Engineers Group, Israel [SE]

**Richard P. Bielen**, NFPA Staff Liaison

*This list represents the membership at the time the Committee was balloted on the final text of this edition. Since that time, changes in the membership may have occurred. A key to classifications is found at the back of the document.*

NOTE: Membership on a committee shall not in and of itself constitute an endorsement of the Association or any document developed by the committee on which the member serves.

**Committee Scope:** This Committee shall have primary responsibility for documents on fire protection for telecommunication networks.

## Contents

<b>Chapter 1 Administration</b> .....	76- 4	7.3 Protection from Exposures. ....	76- 24
1.1 Scope. ....	76- 4	7.4 Means of Egress. ....	76- 24
1.2 Purpose. ....	76- 4	7.5 Means for Depowering. ....	76- 24
1.3 Application. ....	76- 4	7.6 Telecommunications Equipment Areas. ....	76- 24
1.4 Retroactivity. ....	76- 4	7.7 Building Services Equipment. ....	76- 25
1.5 Design Options. ....	76- 4	7.8 Emergency Lighting. ....	76- 25
1.6 Equivalency. ....	76- 5		
<b>Chapter 2 Referenced Publications</b> .....	76- 5	<b>Chapter 8 Fire Protection Elements</b> .....	76- 25
2.1 General. ....	76- 5	8.1 General. ....	76- 25
2.2 NFPA Publications. ....	76- 5	8.2 Construction. ....	76- 25
2.3 Other Publications. ....	76- 5	8.3 Compartmentation. ....	76- 25
2.4 References for Extracts in Mandatory Sections. ...	76- 6	8.4 Alarm Processing. ....	76- 26
		8.5 Fire Detection. ....	76- 27
<b>Chapter 3 Definitions</b> .....	76- 6	8.6 Fire-Extinguishing Systems. ....	76- 29
3.1 General. ....	76- 6	8.7 Smoke Management Systems. ....	76- 29
3.2 NFPA Official Definitions. ....	76- 6	8.8 Telecommunications Equipment Ignition and Fire Performance. ....	76- 29
3.3 General Definitions. ....	76- 6		
3.4 Area Definitions. ....	76- 7	<b>Chapter 9 Fire Prevention</b> .....	76- 31
3.5 Detection Systems Definitions. ....	76- 7	9.1 Housekeeping. ....	76- 31
3.6 Equipment Definitions. ....	76- 8	9.2 Telecommunications Electrical Equipment and Wiring. ....	76- 31
3.7 Performance-Based Approach Definitions. ....	76- 8	9.3 Nontelecommunications Electrical Equipment and Wiring. ....	76- 31
3.8 Aisle Containment Definitions. ....	76- 8	9.4 Construction, Alterations, and Equipment Installations. ....	76- 31
<b>Chapter 4 Risk Considerations</b> .....	76- 9	9.5 Employee Awareness. ....	76- 32
4.1 Risk Factors. ....	76- 9	9.6 Means of Egress. ....	76- 32
4.2 Service Continuity Risks. ....	76- 9	9.7 Displays and Decorations. ....	76- 32
		9.8 Cable Management. ....	76- 32
<b>Chapter 5 Performance-Based Approaches</b> .....	76- 9	<b>Chapter 10 Pre-Fire Planning, Damage Control, and Emergency Recovery</b> .....	76- 32
5.1 General. ....	76- 9	10.1 General. ....	76- 32
5.2 Performance Objectives. ....	76- 10	10.2 Life Safety of Occupants of the Facility. ....	76- 32
5.3 Performance Criteria. ....	76- 10	10.3 Fire Safety of Fire Fighters. ....	76- 32
5.4 Design Assumptions. ....	76- 10	10.4 Selective Depowering. ....	76- 32
5.5 Fire Scenarios. ....	76- 10		
5.6 Methods of Assessing Performance. ....	76- 12	<b>Chapter 11 Small Unoccupied Structures</b> .....	76- 33
5.7 Documentation. ....	76- 12	11.1 Scope. ....	76- 33
5.8 Acceptance. ....	76- 12	11.2 General. ....	76- 33
<b>Chapter 6 Prescriptive-Based Approaches</b> .....	76- 12		
6.1 General. ....	76- 12	<b>Annex A Explanatory Material</b> .....	76- 33
6.2 Construction. ....	76- 13		
6.3 Protection from Exposures. ....	76- 13	<b>Annex B Performance Test Procedures for Very Early Warning and Early Warning Fire Detection Systems</b> .....	76- 54
6.4 Means of Egress. ....	76- 13		
6.5 Means for Selective Depowering. ....	76- 13	<b>Annex C Hazard Areas and Other Issues of Concern</b> .	76- 57
6.6 Building Services Equipment. ....	76- 13		
6.7 Emergency Lighting. ....	76- 13	<b>Annex D Smoke Management</b> .....	76- 58
6.8 Signal-Processing Equipment Area. ....	76- 13		
6.9 Cable Entrance Facility Area. ....	76- 16	<b>Annex E Pre-Fire Planning</b> .....	76- 59
6.10 Power Areas. ....	76- 17		
6.11 Main Distribution Frame Areas. ....	76- 20	<b>Annex F Assumptions Related to Specific Hazard Areas</b> .....	76- 60
6.12 Standby Engine Areas. ....	76- 21		
6.13 Technical Support Areas. ....	76- 22	<b>Annex G Informational References</b> .....	76- 61
6.14 Administrative Areas. ....	76- 22		
6.15 Building Service and Support Areas. ....	76- 23	<b>Index</b> .....	76- 64
<b>Chapter 7 Redundant or Replacement-Based Approaches</b> .....	76- 23		
7.1 Redundancy or Replacement Approach. ....	76- 23		
7.2 Construction. ....	76- 24		

## NFPA 76

## Standard for the

Fire Protection of Telecommunications  
Facilities

2020 Edition

**IMPORTANT NOTE:** This NFPA document is made available for use subject to important notices and legal disclaimers. These notices and disclaimers appear in all publications containing this document and may be found under the heading “Important Notices and Disclaimers Concerning NFPA Standards.” They can also be viewed at [www.nfpa.org/disclaimers](http://www.nfpa.org/disclaimers) or obtained on request from NFPA.

**UPDATES, ALERTS, AND FUTURE EDITIONS:** New editions of NFPA codes, standards, recommended practices, and guides (i.e., NFPA Standards) are released on scheduled revision cycles. This edition may be superseded by a later one, or it may be amended outside of its scheduled revision cycle through the issuance of Tentative Interim Amendments (TIAs). An official NFPA Standard at any point in time consists of the current edition of the document, together with all TIAs and Errata in effect. To verify that this document is the current edition or to determine if it has been amended by TIAs or Errata, please consult the National Fire Codes® Subscription Service or the “List of NFPA Codes & Standards” at [www.nfpa.org/docinfo](http://www.nfpa.org/docinfo). In addition to TIAs and Errata, the document information pages also include the option to sign up for alerts for individual documents and to be involved in the development of the next edition.

**NOTICE:** An asterisk (\*) following the number or letter designating a paragraph indicates that explanatory material on the paragraph can be found in Annex A.

A reference in brackets [ ] following a section or paragraph indicates material that has been extracted from another NFPA document. Extracted text may be edited for consistency and style and may include the revision of internal paragraph references and other references as appropriate. Requests for interpretations or revisions of extracted text shall be sent to the technical committee responsible for the source document.

Information on referenced and extracted publications can be found in Chapter 2 and Annex G.

## Chapter 1 Administration

**1.1\* Scope.** This standard provides requirements for fire protection of telecommunications facilities, including landline, cable, wireless, and satellite telecommunication services such as telephone/voice, voice over internet protocol (VoIP), internet, data, and video transmission that are rendered to the public.

**1.1.1** Telecommunications facilities include signal-processing equipment areas, cable entrance facility areas, power areas, main distribution frame areas, standby engine areas, technical support areas, administrative areas, and building services and support areas occupied by a telecommunications service provider.

**1.2\* Purpose.** The provisions of this standard shall provide a minimum level of fire protection in telecommunications facilities, provide a minimum level of life safety for the occupants, and protect the telecommunications equipment and service continuity.

**1.3\* Application.** The provisions of this standard shall provide a reasonable level of protection from loss of life, property, and service continuity from fire.

**1.3.1** The requirements of Chapter 4 shall determine the fire protection program for each facility.

**1.3.1.1** Provisions for small structures that are normally unoccupied and that house telecommunications equipment, including on-grade, walk-in cabinets; on-grade huts; cell huts; and controlled environmental vaults (CEVs), are provided in Chapter 11.

**1.3.2\*** For purposes of application of NFPA 101 and NFPA 5000, telecommunications facilities shall be classified as special-purpose industrial occupancies.

**N 1.3.3** This standard shall apply to free-standing telecommunications facilities, as well as joint-use facilities where separated by a fire-resistance-rated partition in accordance with 6.1.4.2.

**1.4 Retroactivity.** The provisions of this standard reflect a consensus of what is necessary to provide an acceptable degree of protection from the hazards addressed in this standard at the time this standard was issued.

**1.4.1** Unless otherwise specified, the provisions of this standard shall not apply to telecommunications facilities that existed or were approved for construction or installation prior to the effective date of this standard.

**1.4.1.1** Building alterations or new equipment installations in existing facilities shall provide a reasonable level of fire protection for the changed purposes of the facility.

**1.4.1.2** Fire protection systems in excess of the features required in this standard shall be permitted to be left in service, removed, or abandoned in place.

**1.4.1.3** Fire protection systems abandoned in place shall be clearly identified as no longer being in service.

**1.4.2** The provisions of Chapters 9 and 10 shall apply to new and existing telecommunications facilities.

**1.4.3** In those cases where the authority having jurisdiction determines that the existing situation presents an unacceptable degree of risk, the authority having jurisdiction shall be permitted to apply retroactively any portions of this standard deemed appropriate.

**1.4.4** The retroactive requirements of this standard shall be permitted to be modified if their application clearly would be impractical in the judgment of the authority having jurisdiction and only where it is clearly evident that a reasonable degree of safety is provided.

**1.5\* Design Options.**

**1.5.1** Fire protection for the individual hazard areas identified in the standard shall be based on the performance-based approach of Chapter 5, the prescriptive-based approach of Chapter 6, or the redundant- or replacement-based approach of Chapter 7.

**1.5.2\*** Any of the three approaches shall be used selectively by hazard area or in any combination.

**1.5.3** Protection of continuity from fire for telecommunications facilities using redundant or replacement-based approaches shall comply with Chapter 7.

**1.5.4** Chapters 1, 4, 9, and 10 shall apply to all telecommunications facilities within the scope of this standard except those covered by Chapter 11, regardless of the design approach taken.

**1.6 Equivalency.** Nothing in this standard is intended to prevent the use of calculation methods, test methods, systems, methods, or devices of superior quality, strength, fire resistance, effectiveness, durability, and safety as alternatives to those required by this standard, provided technical documentation is submitted to the authority having jurisdiction to demonstrate equivalency, and the system, method, or device is approved for the intended purpose.

## Chapter 2 Referenced Publications

**2.1 General.** The documents or portions thereof listed in this chapter are referenced within this standard and shall be considered part of the requirements of this document.

**2.2 NFPA Publications.** National Fire Protection Association, 1 Batterymarch Park, Quincy, MA 02169-7471.

NFPA 1, *Fire Code*, 2018 edition.

NFPA 10, *Standard for Portable Fire Extinguishers*, 2018 edition.

NFPA 12A, *Standard on Halon 1301 Fire Extinguishing Systems*, 2018 edition.

NFPA 13, *Standard for the Installation of Sprinkler Systems*, 2019 edition.

NFPA 14, *Standard for the Installation of Standpipe and Hose Systems*, 2019 edition.

NFPA 25, *Standard for the Inspection, Testing, and Maintenance of Water-Based Fire Protection Systems*, 2020 edition.

NFPA 30, *Flammable and Combustible Liquids Code*, 2018 edition.

NFPA 37, *Standard for the Installation and Use of Stationary Combustion Engines and Gas Turbines*, 2018 edition.

NFPA 51B, *Standard for Fire Prevention During Welding, Cutting, and Other Hot Work*, 2019 edition.

NFPA 54/ANSI Z223.1, *National Fuel Gas Code*, 2018 edition.

NFPA 58, *Liquefied Petroleum Gas Code*, 2020 edition.

NFPA 70®, *National Electrical Code*®, 2020 edition.

NFPA 72®, *National Fire Alarm and Signaling Code*®, 2019 edition.

NFPA 80, *Standard for Fire Doors and Other Opening Protectives*, 2019 edition.

NFPA 80A, *Recommended Practice for Protection of Buildings from Exterior Fire Exposures*, 2017 edition.

NFPA 90A, *Standard for the Installation of Air-Conditioning and Ventilating Systems*, 2018 edition.

NFPA 96, *Standard for Ventilation Control and Fire Protection of Commercial Cooking Operations*, 2017 edition.

NFPA 101®, *Life Safety Code*®, 2018 edition.

NFPA 220, *Standard on Types of Building Construction*, 2018 edition.

NFPA 241, *Standard for Safeguarding Construction, Alteration, and Demolition Operations*, 2019 edition.

NFPA 252, *Standard Methods of Fire Tests of Door Assemblies*, 2017 edition.

NFPA 257, *Standard on Fire Test for Window and Glass Block Assemblies*, 2017 edition.

NFPA 262, *Standard Method of Test for Flame Travel and Smoke of Wires and Cables for Use in Air-Handling Spaces*, 2019 edition.

NFPA 704, *Standard System for the Identification of the Hazards of Materials for Emergency Response*, 2017 edition.

NFPA 750, *Standard on Water Mist Fire Protection Systems*, 2019 edition.

NFPA 780, *Standard for the Installation of Lightning Protection Systems*, 2020 edition.

NFPA 2001, *Standard on Clean Agent Fire Extinguishing Systems*, 2018 edition.

NFPA 5000®, *Building Construction and Safety Code*®, 2018 edition.

### 2.3 Other Publications.

**2.3.1 ASTM Publications.** ASTM International, 100 Barr Harbor Drive, P.O. Box C700, West Conshohocken, PA 19428-2959.

ASTM E84, *Standard Test Method for Surface Burning Characteristics of Building Materials*, 2018.

ASTM E814, *Standard Test Method for Fire Tests of Penetration Firestop Systems*, 2013a, reapproved 2017.

ASTM E1537, *Standard Test Method for Fire Testing of Upholstered Furniture*, 2016.

ASTM E1966, *Standard Test Method for Fire Resistive Joint Systems*, 2015.

**2.3.2 ATIS Publications.** Alliance for Telecommunications Industry Solutions, 1200 G Street NW, Suite 500, Washington, DC 20005.

ATIS 0600307, *Fire Resistance Criteria — Ignitability Requirements for Equipment Assemblies, Ancillary Non-Metallic Apparatus, and Fire Spread Requirements for Wire and Cable*, 2014.

ATIS 0600319, *Equipment Assemblies — Fire Propagation Risk Assessment Criteria*, 2014.

**2.3.3 CSA Publications.** CSA Group, 178 Rexdale Boulevard, Toronto, ON M9W 1R3, Canada.

C22.2 No. 0.3, *Test Methods for Electrical Wires and Cables*, 2009, revised 2014.

**▲ 2.3.4 UL Publications.** Underwriters Laboratories Inc., 333 Pfingsten Road, Northbrook, IL 60062-2096.

ANSI/UL 44, *Thermoset-Insulated Wires and Cables*, 2017.

ANSI/UL 83, *Thermoplastic-Insulated Wire and Cables*, 2017.

ANSI/UL 444, *Communications Cables*, 2017.

ANSI/UL 568, *Nonmetallic Cable Tray Systems*, 2002.

ANSI/UL 723, *Standard for Test for Surface Burning Characteristics of Building Materials*, 2018.

ANSI/UL 900, *Standard for Air Filter Units*, 2015.

ANSI/UL 1277, *Electrical Power and Control Tray Cables with Optional Optical-Fiber Members*, 2018.

ANSI/UL 1564, *Standard for Industrial Battery Chargers*, 2015.

ANSI/UL 1651, *Optical Fiber Cable*, 2015.

ANSI/UL 1666, *Standard Test for Flame Propagation Height of Electrical and Optical-Fiber Cables Installed Vertically in Shafts*, 2007.



ANSI/UL 1685, *Standard for Vertical Tray Fire-Propagation and Smoke-Release Test for Electrical and Optical-Fiber Cables*, 2015.

ANSI/UL 1973 *Standard for Batteries for Use in Stationary, Vehicle Auxiliary Power and Light Electric Rail (LER) Applications*, 2018.

ANSI/UL 2024, *Cable Routing Assemblies and Communications Raceways*, 2014, revised 2015.

ANSI/UL 9540, *Outline of Investigation for Energy Storage Systems and Equipment*, 2016.

ANSI/UL 60950-1, *Information Technology Equipment — Safety — Part 1: General Requirements*, 2007.

### 2.3.5 Other Publications.

California Technical Bulletin 133, *Flammability Test Procedure for Seating Furniture for Use in Public Occupancies*, State of California, Department of Consumer Affairs, 1625 North Market Boulevard, Suite N-119, Sacramento, CA 95834.

*Merriam-Webster's Collegiate Dictionary*, 11th edition, Merriam-Webster, Inc., Springfield, MA, 2003.

Telcordia GR-63-CORE, *Network Equipment Building System (NEBS)<sup>TM</sup> Requirements: Physical Protection*, 2017.

## 2.4 References for Extracts in Mandatory Sections.

NFPA 1, *Fire Code*, 2018 edition.

NFPA 70<sup>®</sup>, *National Electrical Code<sup>®</sup>*, 2017 edition.

NFPA 90A, *Standard for the Installation of Air-Conditioning and Ventilating Systems*, 2018 edition.

NFPA 101<sup>®</sup>, *Life Safety Code<sup>®</sup>*, 2018 edition.

NFPA 805, *Performance-Based Standard for Fire Protection for Light Water Reactor Electric Generating Plants*, 2015 edition.

NFPA 921, *Guide for Fire and Explosion Investigations*, 2017 edition.

NFPA 5000<sup>®</sup>, *Building Construction and Safety Code<sup>®</sup>*, 2018 edition.

## Chapter 3 Definitions

**3.1 General.** The definitions contained in this chapter shall apply to the terms used in this standard. Where terms are not defined in this chapter or within another chapter, they shall be defined using their ordinarily accepted meanings within the context in which they are used. *Merriam-Webster's Collegiate Dictionary*, 11th edition, shall be the source for the ordinarily accepted meaning.

### 3.2 NFPA Official Definitions.

**3.2.1\* Approved.** Acceptable to the authority having jurisdiction.

**3.2.2\* Authority Having Jurisdiction (AHJ).** An organization, office, or individual responsible for enforcing the requirements of a code or standard, or for approving equipment, materials, an installation, or a procedure.

**3.2.3\* Listed.** Equipment, materials, or services included in a list published by an organization that is acceptable to the authority having jurisdiction and concerned with evaluation of products or services, that maintains periodic inspection of production of listed equipment or materials or periodic evaluation of services, and whose listing states that either the equipment, material, or service meets appropriate designated

standards or has been tested and found suitable for a specified purpose.

**3.2.4 Shall.** Indicates a mandatory requirement.

**3.2.5 Standard.** An NFPA Standard, the main text of which contains only mandatory provisions using the word “shall” to indicate requirements and which is in a form generally suitable for mandatory reference by another standard or code or for adoption into law. Nonmandatory provisions are not to be considered a part of the requirements of a standard and shall be located in an appendix, annex, footnote, informational note, or other means as permitted in the NFPA Manuals of Style. When used in a generic sense, such as in the phrase “standards development process” or “standards development activities,” the term “standards” includes all NFPA Standards, including Codes, Standards, Recommended Practices, and Guides.

## 3.3 General Definitions.

**3.3.1 Abandoned Cables.** Installed telecommunications, optical fiber, and electrical power cables that are not terminated at equipment and are not identified for future use.

### **N** 3.3.2 Battery.

**N** **3.3.2.1 Lithium-Ion Battery.** A storage battery that consists of lithium-ions imbedded in a carbon graphite or nickel metal oxide substrate. The electrolyte is a carbonate mixture or a gelled polymer. The lithium-ions are the charge carriers of the battery. [1, 2018]

**N** **3.3.2.2 Nickel Cadmium (NiCd) Battery.** An alkaline storage battery in which the positive active material is nickel oxide, the negative contains cadmium, and the electrolyte is potassium hydroxide. [1, 2018]

**N** **3.3.2.3 Sodium-Nickel Battery.** A hermetically sealed storage battery that consists of a sodium negative electrode, a beta-alumina electrolyte, and a positive electrode of either nickel, nickel-chloride, or sodium-chloride. These batteries operate with an internal temperature over 500°F (260°C).

**N** **3.3.2.4\* Valve-Regulated Lead Acid (VRLA).** A lead-acid battery consisting of sealed cells furnished with a valve that opens to vent the battery whenever the internal pressure of the battery exceeds the ambient pressure by a set amount.

**N** **3.3.2.5\* Vented (Flooded).** A battery consisting of cells that have electrodes immersed in liquid electrolyte.

**3.3.3 Building Automation System.** An automated system used to control building functions such as HVAC control, lighting, and smoke management.

**3.3.4 Cable Routing Assembly.** A single channel or connected multiple channels, as well as associated fittings, forming a structural system that is used to support and route communications wires and cables, optical fiber cables, data cables associated with information technology and communications equipment, Class 2, Class 3, and Type PLTC cables, and power-limited fire alarm cables in plenum, riser, and general purpose applications. [70:100]

**3.3.5 Cable Telecommunications.** One- and two-way communications service provided over a network, generally through optical fiber or coaxial cable.

**3.3.6 Central Office (CO).** A telecommunications facility also known as a telephone exchange, wire center, or switching center.

**3.3.7 Communications Raceway.** An enclosed channel of nonmetallic materials designed expressly for holding communications wires and cables; optical fiber cables; data cables associated with information technology and communication equipment; Class 2, Class 3, and Type PLTC cables; and power-limited fire alarm cables in plenum, riser, and general-purpose applications. [70:100]

**3.3.8 Contractor.** One who contracts on predetermined terms to provide labor and materials and who is responsible for performance of a construction job in accordance with construction documents. [5000, 2018]

**3.3.9 Controlled Environmental Vault (CEV).** A partially or fully subterranean room, accessible by ladder, that houses telecommunications equipment and is under controlled temperature and humidity.

**3.3.10 Firestop.** A specific system, device, or construction consisting of the materials that fill the openings around penetrating items such as cables, cable trays, conduits, ducts, pipes, and their means of support through the wall or floor openings to prevent the spread of fire. [5000, 2018]

#### 3.3.11 Hut.

**3.3.11.1 Cell Hut.** A small structure or enclosure that is normally unoccupied, is dedicated to the housing of cellular or wireless telecommunications equipment, and is associated with a nearby radio tower or antenna.

**3.3.11.2 On-Grade Hut.** A small, on-grade structure or enclosure that is normally unoccupied and houses telecommunications equipment.

**N 3.3.12 Maximum Allowable Quantity (MAQ).** The quantity of hazardous material permitted in a control area. [1, 2018]

**N 3.3.13 Liquid Cooling.** The removal of heat in electronic and mechanical devices through heat transfer properties of liquids.

**3.3.14 Smoke Control.** A system that utilizes fans to produce pressure differences so as to manage smoke movement. [90A, 2018]

**3.3.15 Smoke Management System.** An engineered system that includes all methods that can be used singly or in combination to modify smoke movement.

**3.3.16 Smoke Removal.** The control of smoke accumulation in the space where it is being generated by providing appropriate supply and exhaust to purge the smoke and prevent smoke movement to adjoining spaces.

**3.3.17 Telecommunications.** The transmission, receiving, switching, and management of signals, such as electrical, optical, or electromagnetic, by wire, fiber, or through the air.

**Δ 3.3.18 Telecommunications Facility.** A building or portion of a building that includes a telecommunications equipment area.

**3.3.19 Utility.** An organization, either designated by or recognized by public service commissions or public utility commissions, or recognized as such under federal, state, or local law, that installs, operates, and maintains electric supply or communication systems such as, but not limited to, telephone, wireless, VoIP, CATV, internet, satellite, or data service.

**3.3.20\* Voice over Internet Protocol (VoIP).** Voice communication using internet protocol.

**3.3.21 Walk-In Cabinet.** An ongrade or partially belowgrade room, accessible without a ladder, that houses telecommunications equipment and is under controlled temperature and humidity.

#### 3.4 Area Definitions.

**3.4.1 Administrative Areas.** Areas that typically include general offices (i.e., administrative, accounting, engineering), mailrooms, cafeterias, and customer service operation center types of working environments.

**3.4.2 Building Services and Support Areas.** Areas or rooms that typically include utility areas, mechanical equipment areas, ac electrical switch gear, maintenance shops, loading docks, and associated storage areas.

**3.4.3 Cable Entrance Facility (CEF) Area.** The area or enclosed room of a telecommunications facility that contains cable entrance facility equipment.

**3.4.4 Cable Vault.** See 3.4.3, Cable Entrance Facility (CEF) Area.

**3.4.5 Hazard Area.** An area with specific, established fuel loads and fire hazard characteristics.

**3.4.6 Main Distribution Frame (MDF) Area.** The area or enclosed room of a telecommunications facility that contains main distribution frame (MDF) equipment.

**3.4.7 Nontelecommunications Equipment Area.** An area within a telecommunications facility that is not defined as a telecommunications equipment area, which includes hazard areas such as administrative areas and building services and support areas.

**3.4.8 Power Area.** The area or enclosed room of a telecommunications facility that contains power equipment.

**3.4.9 Signal-Processing Equipment Area.** The area or enclosed room of a telecommunications facility that contains signal-processing equipment.

**3.4.10 Standby Engine Area.** The area or enclosed room of a telecommunications facility that contains standby engine equipment.

**3.4.11\* Technical Support Area.** The area or space within a telecommunications facility that does not contain telecommunications equipment but contains limited furniture or office-type equipment or both and that directly supports the telecommunications equipment area.

**3.4.12\* Telecommunications Equipment Area.** The area or enclosed room of a telecommunications facility that contains telecommunications equipment.

#### 3.5\* Detection Systems Definitions.

**3.5.1 Early Warning Fire Detection (EWFD) Systems.** Systems that use smoke, heat, or flame detectors to detect fires before high heat conditions threaten human life or cause significant damage to telecommunications service.

**3.5.2 Port.** An orifice, through which air is drawn to an air sampling-type detector.

**3.5.3 Sampling Port.** See 3.5.2, Port.

**3.5.4 Standard Fire Detection (SFD) Systems.** Systems that use fire detection–initiating devices to achieve certain life safety and property protection in accordance with applicable standards.

**3.5.5 Very Early Warning Fire Detection (VEWFD) Systems.** Systems that detect low-energy fires before the fire conditions threaten telecommunications service.

### 3.6 Equipment Definitions.

**3.6.1 Building Services Equipment.** Building mechanical, electrical, lighting, and power systems that are found in typical office buildings.

**3.6.2\* Cable Entrance Facility (CEF) Equipment.** The wire and cable in the cable entrance facility.

**3.6.3 Co-Located Telecommunications Equipment.** Telecommunications equipment that is owned or leased and operated by other service providers (i.e., competitive local or long distance telephone service providers, internet service providers, or cable service providers) that is placed in a telecommunications facility owned by a different service provider.

**3.6.4\* Main Distribution Frame (MDF) Equipment.** Rack-mounted termination blocks and electrical protection devices, cabling, wiring, and auxiliary equipment. The MDF wiring arrangement connects the wire and cable coming from the cable entrance facility to the wire and cable running to the signal-processing equipment and secondary cross connect frames.

**3.6.5 Power Equipment.** Power equipment that includes, but is not limited to, batteries, rectifiers, inverters, distribution cabinets, bus bars, and cabling and that primarily provides dc power to the signal-processing equipment.

**3.6.6\* Signal-Processing Equipment.** The electronic equipment that performs the signal-processing operations such as switch or transport for audio, video, and data signals.

**3.6.7 Standby Engine Equipment.** Standby engine equipment that includes, but is not limited to, a reciprocating engine or turbine, a generator, starter batteries, and associated cabling and that provides standby power to the signal-processing equipment and potentially the entire telecommunications facility if the electrical utility's power is interrupted.

**△ 3.6.8 Telecommunications Equipment.** Equipment and systems normally found in a telecommunications facility that are used for transmitting, receiving, switching, and managing signals such as electrical, optical, or electromagnetic, by wire, fiber, or through the air through the use of wire, cable, and electrical/electronic equipment including signal-processing equipment, cable entrance equipment, batteries and power equipment, main distribution frame equipment, and standby engine equipment.

### 3.7 Performance-Based Approach Definitions.

#### 3.7.1 Analysis.

**3.7.1.1 Sensitivity Analysis.** An analysis performed to determine the degree to which a predicted output will vary given a specified change in an input parameter, usually in relation to models. [5000, 2018]

**3.7.1.2 Uncertainty Analysis.** An analysis performed to determine the degree to which a predicted value will vary. [5000, 2018]

**3.7.2\* Exposure Fire.** A fire that starts at a location that is remote from the area being protected and grows to expose that which is being protected. [101, 2018]

**3.7.3\* Fire Model.** Mathematical prediction of fire growth, environmental conditions, and potential effects on structures, systems, or components based on the conservation equations or empirical data. [805, 2015]

**3.7.4\* Fire Scenario.** A set of conditions that defines the development of fire, the spread of combustion products throughout a building or portion of a building, the reactions of people to fire, and the effects of combustion products. [101, 2018]

**3.7.5 Fuel Load.** The total quantity of combustible contents of a building, space, or fire area, including interior finish and trim, expressed in heat units or the equivalent weight in wood. [921, 2017]

**3.7.6 Incapacitation.** A condition under which humans do not function adequately and become unable to escape untenable conditions. [101, 2018]

**3.7.7 Occupant Characteristics.** The abilities or behaviors of people before and during a fire. [101, 2018]

**3.7.8\* Performance Criteria.** Threshold values on measurement scales that are based on quantified performance objectives. [101, 2018]

**3.7.9 Proposed Design.** A design developed by a design team and submitted to the authority having jurisdiction for approval. [101, 2018]

**3.7.10 Safe Location.** A location remote or separated from the effects of a fire so that such effects no longer pose a threat. [101, 2018]

**3.7.11 Safety Factor.** A factor applied to a predicted value to ensure that a sufficient safety margin is maintained. [101, 2018]

**3.7.12 Safety Margin.** The difference between a predicted value and the actual value where a fault condition is expected. [101, 2018]

**3.7.13 Verification Method.** A procedure or process used to demonstrate or confirm that the proposed design meets the specified criteria. [101, 2018]

### 3.8 Aisle Containment Definitions.

**3.8.1\* Aisle.** The passageway between telecommunications equipment or between telecommunications equipment and a wall that allows personnel access to the equipment for service or operation of the equipment.

**3.8.2\* Aisle Containment.** An HVAC method deployed in the occupied area of an air-cooled telecommunications equipment space utilizing nonstructural separation of hot exhaust air from cooler intake air between equipment cabinets, rows of cabinets, or associated power and cooling infrastructure; containment is typically above and at both ends of a hot aisle or a cold aisle, in whole or part.

**3.8.3\* Cold Aisle.** The aisle in front of the airflow intakes on the telecommunications equipment where HVAC cooling airflow is controlled.

**3.8.4\* Hot Air Collar.** An air conveyance assembly used to direct heated exhaust air from telecommunications equipment cabinet(s), enclosure(s), or rack(s) directly to a return air path.

**3.8.5\* Hot Aisle.** The aisle at the rear of the telecommunications equipment where heated exhaust air is controlled and directed into the aisle for return to the HVAC equipment.

## Chapter 4 Risk Considerations

**4.1 Risk Factors.** Fire protection programs for telecommunications facilities shall be determined based on an evaluation of the risks and hazards associated with the site and services provided from the facility and the business continuity planning and disaster restoration capabilities of the telecommunications service provider specific to the site.

**4.1.1** Fire protection programs shall be established with consideration given to the following factors:

- (1) Exposure threat to facility occupants, the general public, and exposed property from a fire occurring at, adjacent to, or within the facility
- (2) The importance of telecommunications service continuity in supporting public safety through emergency communications (such as 911), national defense communications requirements, video transmission of critical medical operations, and other vital data
- (3) Methods employed by a service provider, as part of a risk management or business continuity strategy, that allow service to remain viable during and after an event or to be replaced or restored
- (4) The potential for a given protection strategy to result in a service disruption or inhibit the ability of the service provider to restore service in a timely manner post-event

**4.1.2\*** Telecommunications equipment areas located in a structure or building housing multiple tenants or occupancies that are or are not associated with the telecommunications equipment areas shall include additional risk analysis.

### 4.2 Service Continuity Risks.

**4.2.1\* Evaluation of Loss of Operations.** In assessing and evaluating the damage and interruption potential of the loss of communication operations, attention shall be given to the impact of the loss of data, voice, and video communications links.

#### 4.2.2 Risk Management Considerations.

**4.2.2.1** The following elements shall be documented as part of the risk management analysis:

- (1) Life safety
- (2) Service continuity
- (3) Economic impact to customers due to loss of connectivity of voice and data
- (4) Size and value of the facility
- (5) Restoration plans
- (6) Availability of readily deployable replacement telecommunications infrastructure

- (7) Response time to an alarm
- (8) Local fire-fighting capabilities
- (9) Redundant telecommunications infrastructure
- (10) Reputation impact

**4.2.2.2** A fire protection program shall be developed in conjunction with the considerations in 4.2.2 resulting in the use of one or more of the following strategies for areas within the telecommunications facility:

- (1) Performance-based approaches in accordance with Chapter 5
- (2) Prescriptive-based approaches in accordance with Chapter 6
- (3) Redundant facilities or plan for rapid replacement in accordance with Chapter 7

## Chapter 5 Performance-Based Approaches

### 5.1 General.

**5.1.1\* Application.** This chapter applies to telecommunications facilities, or a hazard within, designed to the performance-based option of Section 1.5.

**5.1.2\* Approved Qualifications.** The performance-based design shall be prepared by a person with qualifications acceptable to the authority having jurisdiction.

**5.1.3\* Independent Review.** An independent third-party review of the proposed design shall be conducted.

**5.1.4 Final Determination.** The authority having jurisdiction shall make the final determination as to whether a design meets the performance objectives of this standard.

**5.1.5\* Maintenance of Design Features.** For the design features for each hazard area to continue to meet the performance goals and objectives of this standard, the design features shall be maintained for the life of the facility.

**5.1.5.1** Compliance with all originally documented design assumptions and specifications shall be maintained.

**5.1.5.2** Any variations from the design assumptions or specifications shall be submitted for approval by the authority having jurisdiction prior to the actual change.

**5.1.6 Special Definitions.** A list of terms used in this chapter follows:

- (1) Analysis
  - (a) Sensitivity Analysis. See 3.7.1.1.
  - (b) Uncertainty Analysis. See 3.7.1.2.
- (2) Exposure Fire. See 3.7.2.
- (3) Fire Model. See 3.7.3.
- (4) Fire Scenario. See 3.7.4.
- (5) Fuel Load. See 3.7.5.
- (6) Incapacitation. See 3.7.6.
- (7) Occupant Characteristics. See 3.7.7.
- (8) Performance Criteria. See 3.7.8.
- (9) Proposed Design. See 3.7.9.
- (10) Safe Location. See 3.7.10.
- (11) Safety Factor. See 3.7.11.
- (12) Safety Margin. See 3.7.12.
- (13) Verification Method. See 3.7.13.

## 5.2 Performance Objectives.

**5.2.1 Life Safety Objectives.** The facility design shall provide occupants of the telecommunications facility adequate time to exit the building or to reach a safe area of refuge without being exposed to untenable conditions.

### 5.2.2 Network Objectives.

**5.2.2.1** The facility design shall limit the effects of a worst credible design fire in a nontelecommunications equipment area from causing an unacceptable network failure.

**5.2.2.2** The facility design shall limit the effects of a worst credible design fire in a telecommunications equipment area from causing an unacceptable network failure.

## 5.3 Performance Criteria.

### 5.3.1\* Life Safety Performance Criteria.

**5.3.1.1** The fire protection and life safety design of the facility shall provide for tenable conditions along egress paths for the time required to evacuate occupants to a safe area using either of the following options:

- (1) NFPA 101 performance-based section
- (2) NFPA 101 prescriptive sections for industrial low occupancy

**5.3.1.2** Where the NFPA 101 performance-based methodology is utilized to assess the level of life safety to be provided in the facility, the fire scenarios specified in this document shall be considered along with the scenarios provided in NFPA 101.

### 5.3.2 Network Performance Criteria.

**5.3.2.1\*** Where telecommunications equipment is exposed to a worst credible fire scenario, the facility design shall limit temperatures in a manner that protects against unacceptable network failure.

**5.3.2.2\*** Where telecommunications equipment is exposed to a worst credible fire scenario, the facility design shall limit the effects of products of pyrolysis or combustion in a manner that protects against unacceptable network failure.

## 5.4 Design Assumptions.

**5.4.1 General.** The design shall include documentation on the clear statement, data sources, and topics outlined in 5.4.1.1 through 5.4.1.4.

**5.4.1.1** Assumptions shall provide the design basis for fire scenarios involving telecommunications facilities and shall be presented for those hazard areas expected in telecommunications facilities.

**5.4.1.2** Assumptions used in the performance-based design shall be clearly stated and documented.

**5.4.1.3** The sources of data used in analyses shall be documented.

**5.4.1.4** Assumptions shall include, but not be limited to, the topics addressed in 5.4.2 through 5.4.5.

### 5.4.2 Assumptions Regarding Facility Characteristics.

**5.4.2.1** Assumptions about the building dimensions, construction materials, furnishings, spatial geometry, number and size of openings, and other details that are input into calculations

or models shall be explicitly identified and documented and shall be consistent with the facility construction and content.

**5.4.2.2** Assumptions regarding characteristics of the building or its contents, telecommunications equipment, or operations not inherent in the design specifications but that affect occupant behavior or the rate of hazard development shall be identified and documented.

### 5.4.3\* Assumptions Regarding Operational Status and Effectiveness of Building Features and Systems.

**5.4.3.1** All fire protection systems and features of the building shall comply with applicable NFPA standards for those systems and features.

**5.4.3.2** The assumption of full operability and reliability shall not apply to those systems or features for which a scenario is specifically and explicitly defined to involve the impairment of that system or feature.

**5.4.3.3\*** Assumptions about the performance of fire protection systems and building features shall be limited to the documented performance of the components of those systems or features.

**5.4.4 Assumptions Regarding Emergency Response Personnel.** Assumptions regarding the availability, speed of response, effectiveness, roles, and other characteristics of emergency response personnel shall be explicitly identified and documented.

**5.4.5 Assumptions Regarding Off-Site Conditions.** Assumptions regarding resources or conditions outside the property being designed that affect the ability of the building to meet the stated goals and objectives shall be identified and documented.

**5.4.6 Consistency of Assumptions.** The design shall not include mutually inconsistent assumptions.

**5.4.7 Specific Facility Hazard Areas Assumptions.** Assumptions shall provide the design basis for fire scenarios involving telecommunications facilities.

**5.4.7.1** To facilitate design, analysis, and review, assumptions shall be presented for those hazard areas expected in telecommunications facilities.

**5.4.7.2** Additional provisions not covered by the assumptions in Section 5.4 but that are necessary for the design to comply with the performance objectives shall be documented. (*See Annex F for assumptions applicable to specific facility hazard areas.*)

## 5.5\* Fire Scenarios.

**5.5.1 Design Fires.** A performance-based design shall be based on the evaluation of fire safety design alternatives against design fires considered in the fire scenarios in 5.5.2.1 through 5.5.2.1.8.2.

**5.5.1.1\*** Design fires shall be developed for each scenario using a method acceptable to the authority having jurisdiction and appropriate for the conditions.

**5.5.1.2** The proposed design shall meet the goals and objectives if it achieves the performance criteria for each scenario.

**5.5.2 Design Fire Scenarios.****5.5.2.1\* Specified Scenarios.****5.5.2.1.1 General.**

**5.5.2.1.1.1** The evaluation of alternative designs against the scenario shall consider the following:

- (1) Actual or intended construction and geometry of confining boundaries
- (2) Size, configuration, and location of ventilation openings if any

**5.5.2.1.1.2** Other scenarios shall be developed as needed to meet specific design situations.

**5.5.2.1.1.3** Although life safety might not be a factor in all scenarios, the potential of occupant exposure to fire shall be considered in scenario development.

**5.5.2.1.2\* Electrical Component or Systems Fires.**

**5.5.2.1.2.1** These scenarios shall be representative of a fire that is as follows:

- (1) Ignited by an electrical overload or component failure in an electrical component or system
- (2) Located in a rack or cabinet
- (3) Located in a room dedicated to telecommunications operations that directly support network service

**5.5.2.1.2.2** The design fire developed for these scenarios shall address the following:

- (1) The early stages in the fire development when the major damage mechanism is exposure of telecommunications equipment and circuits in proximity to the failed components in the rack or cabinet to corrosive and conductive products of combustion
- (2) Fire spread to other racks in a cabinet or cabinet-to-cabinet spread if the materials of construction and configuration facilitate such fire growth

**5.5.2.1.3\* Communications Cable or Power Cable Fires.**

**5.5.2.1.3.1** These scenarios shall be representative of a fire in cables or wires installed in or passing through the compartments under analysis.

**5.5.2.1.3.2** The design fire developed for these scenarios shall consider the following:

- (1) The early stages in the fire development when the major damage mechanism is exposure of telecommunications equipment and circuits in the compartments to corrosive and conductive products of combustion
- (2) The later stage fire growth and peak heat release rates that could result in fire extension to additional fuel packages or compartments

**5.5.2.1.4\* Nontelecommunications Equipment Fires.**

**5.5.2.1.4.1** The following scenarios shall be representative of a free-burning fire:

- (1) Involvement with ordinary combustibles
- (2) Ignition by a small open flame source
- (3) Fire in technical support areas and ancillary areas such as administrative areas and building support areas where telecommunications equipment is not exposed or in areas containing telecommunications equipment

**5.5.2.1.4.2** The design fire developed for these scenarios shall consider fire growth and peak heat release rates that could result in fire extension to additional fuel packages or compartments.

**5.5.2.1.5\* Ignitable Liquid Fires.**

**5.5.2.1.5.1** These scenarios shall consider the following:

- (1) Ignition of any flammable or combustible liquids located within the area in question
- (2) Subsequent ignition of exposed combustibles
- (3) Specific properties of the liquid fuel as related to the development of vapor-air mixtures that could result in deflagrations
- (4) Fire size based on the maximum potential exposed liquid surface area
- (5) Presence of liquid release or spill containment barriers

**5.5.2.1.5.2** The design fire developed for these scenarios shall consider the following:

- (1) Rapid fire growth
- (2) Short time to reach peak heat release rates
- (3) Compartment damage that could result in rapid fire extension to additional compartments

**5.5.2.1.6\* Combustible Gas Fires.**

**5.5.2.1.6.1** These scenarios shall consider the following:

- (1) Those areas with the potential for the buildup and ignition of combustible gases
- (2) Rapid pressure rise with damage to exposed telecommunications equipment and compartment boundaries
- (3) Subsequent fire or rapid ignition of easily ignited combustible materials within the space or a combination of both

**5.5.2.1.6.2** Fire exposure to adjacent telecommunications equipment and telecommunications equipment areas shall be based on the sustained burning of combustible materials within the area.

**5.5.2.1.6.3** The design fire developed for these scenarios shall consider damage to telecommunications equipment and compartment boundaries due to the following:

- (1) Thermal and pressure effects from an explosion or deflagration
- (2) Rapid fire extension to additional compartments

**5.5.2.1.7\* Interior Exposure Fires.**

**5.5.2.1.7.1** These scenarios shall be representative of spread of fire and of passage of fire products as follows:

- (1) Fire originating in adjacent building spaces, including horizontal exposures
- (2) Exposures from above or below

**5.5.2.1.7.2** The design fire developed for these scenarios shall consider the following:

- (1) The fire growth and peak heat release rates in the exposing compartment
- (2) The fire growth and peak heat release rates that would result from fire growth and spread within the exposed compartment

### 5.5.2.1.8\* Exterior Exposure Fires.

**5.5.2.1.8.1** These scenarios shall be representative of damage by exposure to smoke or thermal energy from an uncontrolled fire exterior to the building or space in question and shall consider the following:

- (1) Ignition of combustibles exterior building finishes
- (2) Ignition of building contents exposed through openings or combustibles materials adjacent to building openings
- (3) Damage resulting from smoke or corrosive products of combustion
- (4) Operation of fire detection and suppression systems caused by external smoke conveyed into the building

**5.5.2.1.8.2** The design fire developed for these scenarios shall consider spread by the following:

- (1) Convection
- (2) Radiation
- (3) Direct flame contact

### 5.6 Methods of Assessing Performance.

**5.6.1 General.** A proposed design's performance shall be assessed relative to each performance objective in Section 5.2 and each applicable scenario in Section 5.5, with the assessment conducted through the use of appropriate calculation methods, including computerized modeling programs.

**5.6.1.1** The proposed design shall be deemed to meet the goals and objectives if it achieves the performance criteria for each scenario.

**5.6.1.2** The installation shall be deemed to meet the goals and objectives if its performance is verified.

**5.6.2 Use.** The design professional shall use the assessment methods to demonstrate that the proposed design will achieve the goals and objectives, as measured by the performance criteria in light of the safety margins and uncertainty analysis, for each scenario, given the assumptions.

**5.6.3 Safety Factors.** Safety factors shall be included in the design methods and calculations to reflect uncertainty in the assumptions and other factors associated with the performance-based design.

**5.6.4 Output Data.** The assessment methods used shall accurately and appropriately produce the necessary output data from input data based on the design specifications, assumptions, and scenarios.

**5.6.5 Validity.** Evidence shall be provided confirming that the assessment methods are valid and appropriate for the proposed facility, use, and conditions.

**5.6.5.1** The validity and applicability of all mathematical models, computer models, scale models, or any combination used in developing a performance-based design shall be documented.

**5.6.5.2** Limitations of models used shall be clearly stated.

**5.6.6\* Methods for Verifying Performance.** The performance predicted by the performance design analysis shall be verified by field testing of the installed systems and subsystems.

### 5.7 Documentation.

**5.7.1 General.** All aspects of the design, including those described in 5.7.2 through Section 5.8, shall be documented.

**5.7.2 Hazard Mitigation Specifications.** All details of the proposed hazard mitigation plan to meet the stated goals and objectives shall be documented.

**5.7.3 Building Design Specifications.** All details of the proposed building design that affect the ability of the building to meet the stated goals and objectives shall be documented.

**5.7.4 Survivability Criteria.** Survivability criteria, with sources, shall be documented.

**5.7.5 Fire Scenarios.** Descriptions of fire scenarios shall be documented.

**5.7.6 Input Data.** Input data to models and assessment methods, including sensitivity analysis, shall be documented.

**5.7.7 Output Data.** Output data from models and assessment methods, including sensitivity analysis, shall be documented.

**5.7.8 Safety Factors.** Safety factors utilized shall be documented.

**5.7.9 Prescriptive Elements.** Any prescriptive elements used shall be documented.

**5.8 Acceptance.** Acceptance testing, evaluation, and approval by the authority having jurisdiction shall be documented.

## Chapter 6 Prescriptive-Based Approaches

### 6.1 General.

**6.1.1\* Application.** This chapter applies to telecommunications facilities, or a hazard area within, designed to the prescriptive-based option of Section 1.5.

#### 6.1.2\* Prescriptive Approach.

**6.1.2.1** Where the performance-based approach of Chapter 5 or the redundant- or replacement-based approach of Chapter 7 are not used, the prescriptive requirements of this chapter shall apply.

**6.1.2.2** Where two or more of the following equipment or hazard areas are within a single enclosed room, the most restrictive requirements shall be applicable to the entire enclosed room:

- (1) Heating, ventilating, and air-conditioning (HVAC) equipment installed to provide environmental control dedicated to the telecommunications equipment or telecommunications equipment areas
- (2) Signal-processing equipment areas or signal-processing equipment
- (3) Cable entrance facility areas or cable entrance facility equipment
- (4) Power areas or power equipment
- (5) Main distribution frame areas or main distribution frame equipment
- (6) Technical support areas

**6.1.3\* Determination of Signal-Processing Equipment Area.** To determine which requirements to comply with in this chapter, the size of signal-processing equipment area shall be determined based on the total accumulated floor area(s) occupied by signal-processing equipment, including the access aisles between equipment and a 0.6 m (2 ft) wide access zone around the perimeter of signal-processing equipment.

### 6.1.4\* Multiple Tenant Buildings.

**6.1.4.1** Telecommunications facilities in multiple tenant buildings not controlled by a telecommunications service provider shall be housed in one of the following:

- (1) A building constructed in accordance with NFPA 220 Type I (443) or Type II (222) or (111)
- (2) A building provided with an automatic suppression system
- (3) A single-story building constructed in accordance with NFPA 220 Type II (000)

**6.1.4.2** The telecommunications facility shall be separated from the remainder of the building by 2-hour fire-resistance-rated partitions.

**6.1.4.2.1** HVAC penetrations in the telecommunications facility's required fire-resistance-rated partitions shall be in accordance with Section 6.6.

**6.1.4.2.2** Within the building selected, the balance of this standard shall apply only to the telecommunications facility.

**6.1.5 Co-Located Telecommunications Equipment.** Major co-located telecommunications equipment installation, operation, and maintenance shall meet the requirements of this chapter.

**6.2 Construction.** Building construction shall be in accordance with Section 8.2.

**6.3\* Protection from Exposures.** Exterior walls and openings shall be protected as required by the building code or shall be protected in accordance with the provisions of NFPA 80A where no building code is adopted.

**6.4\* Means of Egress.** Means of egress shall be provided in accordance with NFPA 101 special-purpose industrial occupancy.

**6.4.1** Aisles serving equipment frame lineups intended solely to support maintenance and wiring operations shall be permitted to be a minimum of 55.9 cm (22 in.) clear width.

**6.4.2** Where one side of the equipment frame lineup perpendicular to the aisles is provided with emergency illumination and signage, no emergency illumination or exit signage shall be required for the maintenance and wiring aisles within the equipment frame area.

**6.5\* Means for Selective Depowering.** Telecommunications facilities containing more than 232 m<sup>2</sup> (2500 ft<sup>2</sup>) of signal-processing equipment area shall be provided with a selective means for depowering in accordance with 6.5.1 and 6.5.2. (See Annex E.)

**6.5.1\*** Means to selectively depower the building services equipment, power and lighting circuits, and telecommunications equipment shall be identified for incident intervention.

**6.5.2\*** Power distribution equipment with appropriate marking shall be permitted to be used as a means to selectively depower. (See Section 10.4 for an example.)

### 6.6 Building Services Equipment.

**6.6.1\*** Where an HVAC system is provided, it shall comply with one of the following:

- (1) An independent HVAC system that is dedicated for a single hazard area shall be provided.

- (2) An HVAC system that serves multiple hazard areas shall have automatic smoke dampers or combination fire/smoke dampers where they penetrate the compartment walls for the signal-processing equipment area, power area, or main distribution frame hazard areas.

- (3) An HVAC system that serves a hazard area for which smoke control is installed shall have smoke or combination fire/smoke dampers where they penetrate the compartment walls for which smoke control is installed.

**6.6.1.1** Smoke dampers or combination fire/smoke dampers shall operate upon activation of smoke detectors in accordance with the requirements of NFPA 90A, unless the HVAC system is part of the smoke management system. (See Section 8.7.)

**6.6.2** Smoke dampers or combination fire/smoke dampers installed in the ducts or air transfer openings shall be installed in accordance with NFPA 90A.

**6.6.3** Pipe insulation and coverings, duct coverings, duct linings, vapor retarder facings, adhesives, fasteners, tapes, and supplementary materials added to air ducts, plenums, panels, and duct silencers used in duct systems shall comply with NFPA 90A.

**6.6.4** Air filters for use in HVAC systems shall comply with the requirements of ANSI/UL 900 and NFPA 90A.

**6.6.5** HVAC systems shall be provided with either automatic shutdown or manual shutdown or both.

**6.6.5.1** The automatic shutdown of the HVAC system shall be accomplished through the fire alarm system or the building automation system in accordance with NFPA 72.

**6.6.5.2\*** Automatic shutdown of the HVAC system shall not take place prior to confirmation of the presence of smoke.

**6.6.6** When the affected compartment is smoke isolated from the balance of the facility, the system design shall be reviewed to determine whether the balance of the HVAC system is to continue to operate.

**6.6.7\*** HVAC systems in individual unaffected areas shall be permitted to continue to operate.

**6.6.8\*** HVAC systems in individual affected areas shall be permitted to continue to operate until confirmation of circulation of smoke.

**6.6.9** HVAC units shall be permitted to be shut down on an individual basis.

**6.7 Emergency Lighting.** Emergency lighting shall be provided in the telecommunications facility in accordance with NFPA 101.

**6.7.1\*** The emergency lighting system shall be permitted to be powered by the telecommunications facility battery system.

**6.7.2\*** Where the telecommunications facility battery system is utilized to power the emergency lighting system, it shall have adequate reserves to meet the loads of the telecommunications equipment and the emergency lighting load connected for the minimum time required in accordance with NFPA 101.

### 6.8 Signal-Processing Equipment Area.

**6.8.1\* General.** Signal-processing equipment areas shall be arranged to enhance the survivability of the signal-processing



equipment for continuity of service in accordance with 6.8.2 through 6.8.11.

## 6.8.2 Construction.

**6.8.2.1 Floor/Ceiling Assemblies.** Floor/ceiling assemblies over signal-processing equipment areas shall be constructed to protect against the leakage of water from the roof or occupied areas above.

### 6.8.2.2 Raised Floors.

**6.8.2.2.1** Structural supporting members and decking for raised floors shall be of noncombustible material.

**6.8.2.2.2** Access sections or panels shall be provided in raised floors so that all the space beneath is accessible.

**6.8.2.2.3\*** Dedicated floor puller(s) shall be provided to gain access beneath the raised floor and located at every fire-fighting access route to raised floor areas.

**6.8.2.2.4** Cable openings in floors shall be made smooth or shall be otherwise protected to preclude the possibility of damage to the cables.

**6.8.2.2.5** The space beneath any raised floor shall not be used for storage.

**6.8.2.2.6** Abandoned cables shall be removed provided that they can be removed without damaging adjacent cables and the building structure or finish.

**6.8.3\* Compartmentation.** Signal-processing equipment areas shall be separated from adjacent nontelecommunications equipment areas and standby engine areas by a minimum 1-hour fire-resistive construction in accordance with Sections 8.2 and 8.3.

## 6.8.4 Building Services Equipment.

**6.8.4.1** Where building services equipment is provided, it shall be in accordance with Section 6.6.

**6.8.4.2\*** Building services equipment shall be limited to that needed to support the signal-processing equipment areas and adjacent telecommunications equipment areas.

**6.8.4.3** Telecommunications facilities containing less than 232 m<sup>2</sup> (2500 ft<sup>2</sup>) of signal-processing equipment areas shall not be required to comply with the requirements of 6.6.1(1), 6.6.1(2), and 6.8.4.2.

## 6.8.5 Signal-Processing Equipment.

**▲ 6.8.5.1\*** All signal-processing equipment areas, whether owned or co-located, shall be designated as Level A, Level B, or Level C, based on the classification in accordance with 8.8.3 of the equipment within the area.

**6.8.5.1.1** Where a 1-hour-rated fire separation is provided between signal-processing areas, each area shall be designated as Level A, Level B, or Level C, based on the classification in accordance with 8.8.3 of the signal-processing equipment within the area.

**6.8.5.1.2** All new signal-processing equipment, whether owned or co-located, shall be classified as Level A, Level B, or Level C in accordance with 8.8.3.

**6.8.5.1.3** All new wires and cables, whether owned or co-located, shall be in accordance with 8.8.2.

**6.8.5.2\*** Wires, cables, and signal-processing equipment shall be installed and used in configurations and uses for which they have been tested and qualified.

**6.8.5.3** Signal-processing equipment areas that contain only signal-processing equipment that complies with Level A of 8.8.3, and wires and cables that comply with 8.8.2, shall not require automatic fire suppression or smoke management.

**6.8.5.4** Signal-processing equipment areas that contain Level B signal-processing equipment but no Level C signal-processing equipment, and wires and cables that comply with 8.8.2, shall be protected by one of the following:

- (1) A rated fire separation with a minimum fire resistance of 1 hour between hazard areas, and the hazard area protected throughout by smoke management and sufficient spatial separation to prevent fire and smoke damage to signal-processing equipment other than the signal-processing equipment of fire origin
- (2) A rated fire separation with a minimum fire resistance of 1 hour between hazard areas, and the hazard area protected throughout by automatic fire suppression and sufficient spatial separation to prevent fire and smoke damage to signal-processing equipment other than the signal-processing equipment of fire origin
- (3) A rated fire separation with a minimum fire resistance of 1 hour between hazard areas, with the Level B signal-processing equipment protected by automatic in-cabinet fire detection in compliance with 6.8.6, and in-cabinet fire suppression and sufficient spatial separation to prevent fire and smoke damage to signal-processing equipment other than the signal-processing equipment of fire origin

**6.8.5.4.1** Telecommunications facilities containing less than 232 m<sup>2</sup> (2500 ft<sup>2</sup>) of signal-processing areas shall not be required to comply with 6.8.5.4.

**6.8.5.5** Signal-processing equipment areas that contain Level C signal-processing equipment or wires or cables that do not comply with 8.8.2 shall be separated from other hazard areas with a minimum fire resistance of 1 hour, and the hazard area shall be protected throughout with smoke management, automatic fire suppression, and sufficient spatial separation to prevent fire and smoke damage to signal-processing equipment other than the signal-processing equipment of fire origin.

**6.8.5.5.1** Telecommunications facilities containing less than 232 m<sup>2</sup> (2500 ft<sup>2</sup>) of signal-processing areas shall not be required to comply with 6.8.5.5.

**6.8.5.6** Table 6.8.5.6 shall be used to determine fire protection requirements for signal-processing areas where new signal-processing equipment is added.

**6.8.5.6.1** The fire protection requirements shall be based on the signal-processing equipment combination resulting from the addition of new signal-processing equipment.

**6.8.5.6.2** The gradual conversion of an existing signal-processing equipment hazard area by adding new signal-processing equipment of varying fire resistance shall result in the same level of fire protection as the creation of a new hazard area containing the same classification level of signal-processing equipment within an existing telecommunications facility.

**Table 6.8.5.6 Network Evolution — Fire Protection Requirements: Application for a Signal-Processing Hazard Area to Which New Signal-Processing Equipment Is Being Added, Resulting in a Signal-Processing Equipment Classification Combination**

Signal-Processing Equipment Combination in Hazard Area	Option	Required Fire Protection Elements							Means of Depowering in Compliance with Section 6.5 <sup>g</sup>
		Fire Detection in Compliance with 6.8.6 <sup>a</sup>	Hazard Area Rated Fire Separation <sup>a</sup>	Combination Fire/Smoke Dampers <sup>b</sup>	Smoke Management <sup>c,d</sup>	Sufficient Spatial Separation <sup>e</sup>	In-Cabinet Detection and Suppression <sup>f</sup>	Complete Hazard Area <sup>d</sup>	
Level A		Yes	Yes	Yes	No	No	No	No	Yes
Level B, Select	Option 1	Yes	Yes	Yes	Yes	Yes	No	No	Yes
	Option 2	Yes	Yes	Yes	No	Yes	No	Yes	Yes
	Option 3	Yes	Yes	Yes	No	Yes	Yes	No	Yes
Level C		Yes	Yes	Yes	Yes	Yes	No	Yes	Yes
Levels A & B, Select	Option 1	Yes	Yes	Yes	Yes	Yes	No	No	Yes
	Option 2	Yes	Yes	Yes	No	Yes	No	Yes	Yes
	Option 3	Yes	Yes	Yes	No	Yes	Yes for Level B equipment	No	Yes
Levels A & C		Yes	Yes	Yes	Yes	Yes	No	Yes	Yes
Levels B & C		Yes	Yes	Yes	Yes	Yes	No	Yes	Yes
Levels A, B, & C		Yes	Yes	Yes	Yes	Yes	No	Yes	Yes

Note: Level A — see 8.8.3(1); Level B — see 8.8.3(2); Level C — see 8.8.3(3).

<sup>a</sup>With the addition of new equipment to a hazard area, upgrading of fire separations where they do not exist is provided in order to prevent unacceptable network outages.

<sup>b</sup>Combination fire/smoke dampers are used to prevent fire and smoke damage to other hazard areas.

<sup>c</sup>Smoke management systems are designed for the fires resulting from the selected equipment for the hazard area.

<sup>d</sup>Fire suppression is added to the hazard area if the design fire for the hazard area exceeds smoke management system capabilities to prevent signal-processing equipment damage.

<sup>e</sup>Sufficient spatial separation is provided to prevent fire and smoke damage to telecommunications equipment other than the telecommunications equipment of fire origin.

<sup>f</sup>In-cabinet fire detection in compliance with 6.8.6 and the use of in-cabinet fire suppression can be a more economical method than protection of the entire hazard area.

<sup>g</sup>Selective depowering plan is provided for all options in buildings over 232 m<sup>2</sup> (2500 ft<sup>2</sup>). See Section 6.5.

**6.8.6 Fire Detection.**

**6.8.6.1 General.** In telecommunications facilities containing greater than 232 m<sup>2</sup> (2500 ft<sup>2</sup>) of signal-processing equipment areas, the signal-processing equipment areas shall be provided with a very early warning fire detection (VEWFD) system for detection and alarm processing in accordance with Chapter 8.

**6.8.6.1.1** Raised floor areas that do not have a common airflow above and below the raised floor and contain combustibles below the raised floor shall be provided with an early warning fire detection (EWFD) system below the raised floor.

**6.8.6.1.2** Where raised floor areas share common airflow above and below the raised floor, the VEWFD provided above the raised floor shall be considered adequate to protect the area below the raised floor.

**6.8.6.2 General.** In telecommunications facilities containing 232 m<sup>2</sup> (2500 ft<sup>2</sup>) or less of signal-processing equipment areas, the signal-processing equipment areas shall be provided with an EWFD system for detection and alarm processing in accordance with Chapter 8.

**6.8.6.2.1** Raised floor areas that contain combustibles below the raised floor shall be provided with an EWFD system below the raised floor regardless of common airflow.

**6.8.6.3 Installation, Testing, and Maintenance.** All fire alarm, detection, and alarm notification equipment shall be installed, tested, and maintained in accordance with *NFPA 72*.

**6.8.7 Fire Suppression.**

**6.8.7.1 Portable Fire Extinguishers.** Signal-processing equipment areas shall be provided with listed portable fire extinguishers suitable for use on electronic signal-processing equipment in accordance with 8.6.3.

**6.8.7.2 Automatic Fire Suppression.** Where automatic fire suppression systems are provided, they shall be in accordance with 8.6.1 and 8.6.2.

**6.8.8 Leak Detection for Liquid-Cooled Equipment.**

**6.8.8.1** Where liquid-cooling is used for signal-processing equipment, a leak detection system shall be provided.

**N 6.8.8.2** The leak detection system shall be arranged to notify approved personnel.

**6.8.9 Limitation of Combustibles.** Signal-processing equipment areas shall not be used for the storage of combustible materials or other equipment unrelated to the switching, transmission of voice, data, or video signals, and associated power systems.

**6.8.9.1** Limitations of combustible materials shall be in accordance with Chapter 9.

**6.8.9.2** Technical support areas in accordance with Section 6.13 shall be permitted.

#### **6.8.10 Special Hazards.**

**6.8.10.1** Hazardous operations, such as cutting and welding, shall not be conducted without special permits.

**6.8.10.2** Heat-producing appliances not related to the support of signal-processing equipment shall not be permitted within the area.

**6.8.11 Smoke Management Systems.** Where smoke management systems are provided, they shall comply with Section 8.7.

#### **6.9 Cable Entrance Facility Area.**

**6.9.1\* General.** Cable entrance facility areas shall be arranged to enhance survivability of the cable entrance facility equipment for continuity of service in accordance with 6.9.2 through 6.9.9.

##### **6.9.2 Compartmentation.**

**6.9.2.1** Cable entrance facility areas shall be separated from adjacent telecommunications equipment areas and nontelecommunications equipment areas by a minimum of 2-hour fire-resistance-rated construction in accordance with Sections 8.2 and 8.3.

**6.9.2.2** The required fire resistance shall be permitted to be reduced to 1 hour where the cable entrance facility area is protected throughout by an automatic fire suppression system.

**6.9.2.3** Telecommunications facilities containing less than 232 m<sup>2</sup> (2500 ft<sup>2</sup>) of signal-processing equipment areas shall not be required to comply with 6.9.2.1 and 6.9.2.2.

**6.9.2.4** Telecommunications facilities containing less than 232 m<sup>2</sup> (2500 ft<sup>2</sup>) of signal-processing equipment areas shall have the cable entrance facility areas separated from adjacent nontelecommunications equipment and standby engine areas by a minimum of 1-hour fire-resistance-rated construction in accordance with Sections 8.2 and 8.3.

**6.9.2.5** Compartmentation shall not be required where the cable entrance terminates directly within the main distribution frame area.

##### **6.9.3 Building Services Equipment.**

**6.9.3.1** Where building services equipment are provided, they shall be in accordance with Section 6.6.

**6.9.3.2\*** Building services equipment shall be limited to that needed to support the cable entrance facility area.

#### **6.9.4\* Cable Entrance Facility Equipment.**

**6.9.4.1** All new wire and cables, other than entrance cables, installed in the cable entrance facility area, whether owned or co-located, shall be in accordance with 8.8.2 as appropriate for the type of wire and cable.

**6.9.4.1.1** Cabling installed outside of the telecommunications facility shall be permitted to enter the cable entrance facility area, and it shall not extend beyond the cable entrance facility area.

**6.9.4.2\*** Wire, cable, and equipment shall be installed and used in configurations and uses for which they have been tested and qualified.

**6.9.4.3** Where telecommunications equipment is installed in the cable entrance facility and that telecommunications equipment does not comply with the fire safety requirements of Level A of Section 8.8.3(1), it shall be separated from the remainder of the telecommunications equipment area by either of the following:

- (1) Sufficient spatial separation and smoke management to prevent fire and smoke damage to equipment other than the equipment of fire origin
- (2) A rated fire separation with a minimum fire resistance of 1 hour

#### **6.9.5 Fire Detection.**

##### **6.9.5.1 General.**

**6.9.5.1.1** Cable entrance facility areas shall be provided with an EWFD system for detection and alarm processing in accordance with Chapter 8.

**6.9.5.1.2** Where ambient conditions prohibit the installation of automatic smoke detection, other appropriate automatic fire detection shall be permitted.

**6.9.5.2\* Installation, Testing, and Maintenance.** All fire alarm, detection, and alarm notification equipment shall be installed, tested, and maintained in accordance with *NFPA 72*.

#### **6.9.6 Fire Suppression.**

**6.9.6.1 Portable Fire Extinguishers.** Cable entrance facility areas shall be provided with listed portable extinguishers suitable for use on energized cable and ordinary combustible fires in accordance with 8.6.3.

**6.9.6.2 Automatic Fire Suppression.** Where automatic fire suppression systems are provided, they shall be in accordance with 8.6.1 and 8.6.2.

#### **6.9.7 Limitation of Combustibles.**

**6.9.7.1** Cable entrance facility areas shall not be used for the storage of combustible materials or other equipment not related to the cable entrance facility operations.

**6.9.7.2** Limitations of combustible materials shall be in accordance with Chapter 9.

**6.9.8 Special Hazards.** Cable entrance facility areas shall be vented with either gravity vents or with positive venting in order to minimize the buildup of methane gas.

**6.9.9 Smoke Management Systems.** Where smoke management systems are provided, they shall comply with Section 8.7.

## 6.10 Power Areas.

### 6.10.1\* General.

**6.10.1.1** Power areas shall be arranged to enhance the survivability of power equipment for continuity of service in accordance with 6.10.2 through 6.10.10.

**6.10.1.2** Batteries shall be permitted to be located in a dedicated power area or to be located with the equipment they support.

**6.10.2 Compartmentation.** Power areas shall be separated from adjacent nontelecommunications equipment areas and standby engine areas by a minimum of 1-hour fire-resistance-rated construction in accordance with Sections 8.2 and 8.3.

### 6.10.3 Building Services Equipment.

**6.10.3.1** Where building services equipment is provided, it shall be in accordance with Section 6.6.

**6.10.3.2\*** Building services equipment shall be limited to that needed to support the power area and adjacent telecommunications equipment areas.

**6.10.3.3** Telecommunications facilities containing less than 232 m<sup>2</sup> (2500 ft<sup>2</sup>) of signal-processing equipment area(s) shall not be required to comply with the requirements of 6.10.3.2.

### 6.10.4 Power Equipment.

**6.10.4.1** All new wire, cables, and equipment installed in the power area, whether owned or co-located, shall be in accordance with Section 8.8 as appropriate for the type of wire, cable, and equipment.

**6.10.4.2\*** Wire, cable, and equipment shall be installed and used in configurations and uses for which they have been tested and qualified.

**6.10.4.3** Equipment that does not comply with the fire safety requirements of Level A of 8.8.3(1) shall be separated from the remainder of the telecommunications equipment area by either of the following:

- (1) Sufficient spatial separation and smoke management to prevent fire and smoke damage to equipment other than the equipment of fire origin
- (2) A rated fire separation with a minimum fire resistance of 1 hour

**6.10.4.4** Wire and cable that do not comply with the fire safety requirements of 8.8.2 shall be separated from the remainder of the telecommunications equipment area by either of the following:

- (1) Sufficient spatial separation and smoke management to prevent fire and smoke damage to equipment other than the equipment of fire origin
- (2) A rated fire separation with a minimum fire resistance of 1 hour

### 6.10.5 Fire Detection.

**6.10.5.1 General.** Power areas shall be provided with an EWFD system for detection and alarm processing in accordance with Chapter 8.

**6.10.5.2 Installation, Testing, and Maintenance.** All fire alarm, detection, and alarm notification equipment shall be installed, tested, and maintained in accordance with *NFPA 72*.

## 6.10.6 Fire Suppression.

**6.10.6.1 Portable Fire Extinguishers.** Power areas shall be provided with listed portable extinguishers suitable for use on energized and electronic equipment in accordance with 8.6.3.

**6.10.6.2 Automatic Fire Suppression.** Where automatic fire suppression systems are provided in power areas, they shall be in accordance with 8.6.1 and 8.6.2.

**6.10.7 Limitation of Combustibles.** Power areas shall not be used for the storage of combustible materials or other equipment not related to the power area operations.

**6.10.7.1** Limitation of combustible materials shall be in accordance with Chapter 9.

**6.10.7.2** Technical support areas in accordance with Section 6.13 shall be permitted.

**N 6.10.8 Batteries.** Batteries used in power system areas shall comply with 6.10.8.

### N 6.10.8.1 General.

**N 6.10.8.1.1 Location and Occupancy Separation.** Battery systems shall be permitted in the same room as the equipment that they support. [1:52.2.2.3.1]

**N 6.10.8.1.1.1** Battery systems shall be housed in a noncombustible, locked cabinet or other enclosure to prevent access by unauthorized personnel unless located in a separate equipment room accessible only to authorized personnel. [1:52.2.2.3.2]

**N 6.10.8.1.1.2** Battery systems shall be located in a room separated from other portions of the building by a minimum of a 1-hour fire barrier.

**N 6.10.8.1.1.3** Where telecommunications equipment is located in a structure or building housing multiple tenants or occupancies that include business, industrial, mercantile, or storage, battery systems shall be located in a room separated from other portions of the building by a minimum of a 1-hour fire barrier.

**N 6.10.8.1.1.4** Where telecommunications equipment is located in a structure or building housing multiple tenants or occupancies that include assembly, educational, detention, and correction facilities; health care, ambulatory health, ambulatory care, and day care centers; and residential board and care and residential occupancies, battery systems shall be located in a room separated from other portions of the building by a minimum of a 2-hour fire barrier.

**N 6.10.8.1.2 Environment.** The battery environment shall be controlled or analyzed to maintain temperature in a safe operating range for the specific battery technology used. [1:52.2.2.7]

**N 6.10.8.1.2.1 Labels.** Battery cabinets shall be provided with exterior labels that identify the manufacturer and model number of the system and electrical rating (i.e., voltage and current) of the contained battery system. [1:52.2.2.8.4]

**N 6.10.8.1.2.2 Signs.** Signs shall be provided within battery cabinets to indicate the relevant electrical, chemical, and fire hazard. [1:52.2.2.8.5]

**N 6.10.8.1.3 Seismic Protection.** Battery systems shall be seismically braced in accordance with the building code. [1:52.2.2.9]

**N 6.10.8.2 Lead-Acid and Nickel-Cadmium Batteries.**

**N 6.10.8.2.1 General.** Battery systems having an electrolyte capacity of more than 100 gal (378.5 L) in sprinklered buildings or 50 gal (189.3 L) in unsprinklered buildings for vented lead-acid, nickel-cadmium, and valve-regulated lead-acid (VRLA) batteries shall be in accordance with 6.10.8.2 and Table 6.10.8.2.1.

**N 6.10.8.2.2 Safety Venting.** Batteries shall be provided with safety venting caps per 6.10.8.2.2.1 and 6.10.8.2.2.2 [1:52.2.2.1]

**N 6.10.8.2.2.1 Nonrecombinant Batteries.** Vented lead-acid and nickel-cadmium shall be provided with safety venting caps. [1:52.2.2.1.1]

**N 6.10.8.2.2.2 Recombinant Batteries.** VRLA shall be equipped with self-resealing flame-arresting safety vents. [1:52.2.2.1.2]

**N 6.10.8.2.3 Thermal Runaway.** VRLA systems shall be provided with a listed device or other approved method to preclude, detect, and control thermal runaway. [1:52.2.2.2]

**N 6.10.8.2.4 Spill Control.**

**N 6.10.8.2.4.1** Rooms, buildings, or areas containing free-flowing liquid electrolyte in individual vessels having a capacity of more than 55 gal (208 L) or multiple vessels having an aggregate capacity exceeding 1000 gal (3785 L) shall be provided with spill control to prevent the flow of liquids to adjoining areas. [1:52.2.2.4.1]

**N 6.10.8.2.4.2\*** An approved method and materials for the control of a spill of electrolyte shall be provided that will be capable of controlling a spill from the single largest vessel. [1:52.2.2.4.2]

**N 6.10.8.2.4.3** VRLA batteries with immobilized electrolyte shall not require spill control. [1:52.2.2.4.3]

**N 6.10.8.2.5 Neutralization.**

**N 6.10.8.2.5.1\*** An approved method to neutralize spilled electrolyte shall be provided. [1:52.2.2.5.1]

**N 6.10.8.2.5.2** For VRLA batteries, the method shall be capable of neutralizing a spill from the largest battery to a pH between 7.0 and 9.0. [1:52.2.2.5.2]

**N 6.10.8.2.6\* Ventilation.** For vented lead-acid, vented nickel-cadmium, and VRLA batteries, ventilation shall be provided for

rooms and cabinets in accordance with the mechanical code and one of the following:

- (1) The ventilation system shall be designed to limit the maximum concentration of hydrogen to 1.0 percent of the total volume of the room during the worst-case event of simultaneous “boost” charging of all the batteries, in accordance with nationally recognized standards.
- (2) Continuous ventilation shall be provided at a rate of not less than 1 ft<sup>3</sup>/min/ft<sup>2</sup> (5.1 L/sec/m<sup>2</sup>) of floor area of the room or cabinet.

**N 6.10.8.2.7 Signs.**

**N 6.10.8.2.7.1** Doors or accesses into the following shall be provided with approved signs:

- (1) Rooms containing stationary storage battery systems
- (2) Other areas containing stationary storage battery systems

**N 6.10.8.2.7.2** For rooms that contain VRLA batteries, the signs required by 6.10.8.2.7.1 shall state the following:

This room contains:

- (1) Stationary storage battery systems
- (2) Energized electrical circuits

[1:52.2.2.8.2]

**N 6.10.8.2.7.3** For rooms that contain lead-acid or vented Ni-Cd batteries, the signs required by 6.10.8.2.7.1 shall state the following:

This room contains:

- (1) Stationary storage battery systems
- (2) Energized electrical circuits
- (3) Corrosive battery electrolyte

**N 6.10.8.2.8 Smoke Detection.**

**N 6.10.8.2.8.1** An approved automatic smoke detection system shall be installed in rooms containing stationary battery storage systems in accordance with *NFPA 72*. [1:52.2.2.10]

**N 6.10.8.2.8.2** Normally unoccupied, stand-alone telecommunications structures with a gross floor area of less than 1,500 ft<sup>2</sup> (140 m<sup>2</sup>) shall not be required to have the detection as indicated in 6.10.8.2.8.1. [1:52.2.2.10.2]

**N Table 6.10.8.2.1 Lead-Acid and Nickel-Cadmium Battery Requirements**

Requirement	Nonrecombinant Batteries		Recombinant Batteries
	Vented Lead-Acid	Vented Nickel-Cadmium (Ni-Cd)	Valve-Regulated Lead-Acid (VRLA)
Safety caps	Venting caps	Venting caps	Self-resealing flame-arresting caps
Thermal runaway management	Not required	Not required	Required
Spill control	Required	Required	Not required
Neutralization	Required	Required	Required
Ventilation	Required	Required	Required
Signage	Required	Required	Required
Seismic control	Required	Required	Required
Fire detection	Required	Required	Required

**N 6.10.8.3 Additional Battery Technologies.**

**N 6.10.8.3.1 General.** Lithium-ion or sodium-nickel battery systems having a capacity of more than 20 KWh (18.0 Mega joules) shall be in accordance with 6.10.8.3.

**N 6.10.8.3.1.1** For batteries rated in amp-hours, KWh shall equal rated voltage times amp-hour rating divided by 1000.

**N 6.10.8.3.2 Maximum Allowable Quantities.**

**N 6.10.8.3.2.1** Fire areas within buildings containing stationary storage battery systems exceeding the maximum allowable quantity of 600 KWh (2160 mJ) shall comply with all applicable ordinary-hazard and high-hazard requirements as identified in 6.2.2 of NFPA 101 and the building code.

**N 6.10.8.3.2.2** Where approved by the AHJ, areas containing stationary storage battery systems that exceed 600 KWh (2160 mJ) shall be permitted to be treated as an ordinary-hazard and not a high-hazard classification based on a hazardous mitigation analysis in accordance with 6.10.8.3.4 and large-scale fire and fault condition testing conducted or witnessed and reported by an approved testing laboratory.

**N 6.10.8.3.3\* Battery Arrays.**

**N 6.10.8.3.3.1** Battery arrays shall comply with 6.10.8.3.3.2 and 6.10.8.3.3.3 unless otherwise permitted by 6.10.8.3.3.4 or 6.10.8.3.3.5. [1:52.3.2.3.1]

**N 6.10.8.3.3.2** Storage batteries, prepackaged stationary storage battery systems, and pre-engineered stationary storage battery systems shall be segregated into arrays not exceeding 50 KWh (180 Mega joules) each. [1:52.3.2.3.2]

**N 6.10.8.3.3.3** Each array shall be spaced a minimum 3 ft (914 mm) from other arrays and from walls in the storage room or area. The storage arrangements shall comply with the egress provisions in NFPA 101. [1:52.3.2.3.3]

**N 6.10.8.3.3.4** Listed pre-engineered stationary storage battery systems and prepackaged stationary storage battery systems shall not exceed 250 KWh (900 Mega joules) each. [1:52.3.2.3.4]

**N 6.10.8.3.3.5** The AHJ shall be permitted to approve listed pre-engineered and prepackaged battery arrays with larger capacities or smaller battery array spacing if large-scale fire and fault condition testing conducted or witnessed and reported by an approved testing laboratory is provided showing that a fire involving one array will not propagate to an adjacent array, and be contained within the room for a duration equal to the fire resistance rating of the room separation required by 6.10.8.1.1.3. [1:52.3.2.3.5]

**N 6.10.8.3.4 Hazard Mitigation Analysis.** A failure mode and effects analysis (FMEA) or other approved hazard mitigation analysis shall be provided to the AHJ when any of the following conditions are present:

- (1) Battery technologies not specifically identified in 6.10.8.3.1 are provided.
- (2) More than one stationary storage battery technology is provided in a room or indoor area where there is a potential for adverse interaction between technologies.
- (3) When allowed as a basis for increasing maximum allowable quantities as specified in 6.10.8.3.2.

[1:52.3.2.4]

**N 6.10.8.3.4.1** The analysis shall evaluate the consequences of the following failure modes, and others deemed necessary by the AHJ. Only single failure modes shall be considered for each mode:

- (1) Thermal runaway condition in a single module or array
- (2) Failure of a battery management system
- (3) Failure of a required ventilation system
- (4) Voltage surges on the primary electric supply
- (5) Short circuits on the load side of the stationary battery storage system
- (6) Failure of the smoke detection, fire suppression, or gas detection system

[1:52.3.2.4.1]

**N 6.10.8.3.4.2** The AHJ shall be permitted to approve the hazardous mitigation analysis provided the consequences of the FMEA demonstrate the following:

- (1) Fires or explosions will be contained within unoccupied stationary storage battery system rooms for the minimum duration of the fire resistance rated specified in 6.10.8.1.1.2 or 6.10.8.1.1.3, as applicable
- (2) Fires and explosions in stationary storage battery system cabinets in occupied work centers allow occupants to safely evacuate
- (3) Toxic and highly toxic gases released during charging, discharging, and normal operation shall not exceed the permissible exposure limit (PEL)
- (4) Toxic and highly toxic gases released during fires and other fault conditions shall not reach concentrations in excess of IDLH level in the building or adjacent means of egress routes during the time deemed necessary to evacuate from that area
- (5) Flammable gases released from batteries during charging, discharging, and normal operation shall not exceed 25 percent of the lower flammable limit (LFL)

[1:52.3.2.4.2]

**N 6.10.8.3.4.3** Construction, equipment, and systems that are required for the lithium-ion or sodium-nickel battery systems to comply with the hazardous mitigation analysis shall be installed, maintained, and tested in accordance with nationally recognized standards and specified design parameters.

**N 6.10.8.3.5 Listings.** Storage batteries shall be listed in accordance with ANSI/UL 1973, *Standard for Batteries for Use in Stationary, Vehicle Auxiliary Power and Light Electric Rail (LER) Applications*. Prepackaged and pre-engineered lithium-ion or sodium-nickel battery systems shall be listed in accordance with ANSI/UL 9540, *Outline of Investigation for Energy Storage Systems and Equipment*.

**N 6.10.8.3.5.1\* Prepackaged and Pre-engineered Systems.** Prepackaged and pre-engineered stationary storage battery systems shall be installed in accordance with their listing and the manufacturer's instructions. [1:52.3.2.5.1]

**N 6.10.8.3.6 Installation.**

**N 6.10.8.3.6.1 Battery Management System.** An approved battery management system shall be provided for monitoring and balancing cell voltages, currents, and temperatures within the manufacturer's specifications. The system shall transmit an alarm signal to an approved location if potentially hazardous temperatures or other conditions including short circuits, over-voltage (i.e., overcharge) or under voltage (i.e., over discharge) are detected. [1:52.3.2.6.1]

- N 6.10.8.3.6.2 Battery Chargers.** Battery chargers shall be compatible with the battery manufacturer's electrical ratings and charging specifications. Battery chargers shall be listed in accordance with the ANSI/UL 1564, *Standard for Industrial Battery Chargers*, or provided as part of a listed pre-engineered or prepackaged lithium-ion or sodium-nickel battery system.
- N 6.10.8.3.6.3 Signage.**
- N (A)** Approved signage shall be provided on doors or in approved locations near entrances to battery system rooms.
- N (B)** New signage installations shall require the following items:
- (1) Hazard identification markings in accordance with NFPA 704
  - (2) "This room contains energized battery systems," or the equivalent
  - (3) Identification of the type(s) of batteries present
  - (4) AUTHORIZED PERSONNEL ONLY
  - (5) Any potential hazards associated with the batteries
- N (C)** Where the battery storage system disconnecting means is not within sight of the main service disconnect, placards or directories shall be installed at the locations of the main service disconnect to indicate the location of all battery storage disconnecting means in accordance with *NFPA 70*. [1:52.3.2.6.5.3]
- N (D)** Existing stationary storage battery systems shall be permitted to include the signage required at the time it was installed. [1:52.3.2.6.5.4]
- N (E)** Fire command centers in buildings containing stationary storage battery systems shall include signage or readily available documentation that describes the location of stationary storage battery systems, the types of batteries present, operating voltages, and location of electrical disconnects. [1:52.3.2.6.5.7]
- N 6.10.8.3.6.4\* Mixed Battery Systems.** Different types of batteries shall not be installed in the same room or cabinet if there is a potential for unsafe interaction between them, as determined by the AHJ. [1:52.3.2.6.8]
- N 6.10.8.3.7 Suppression and Detection.**
- N 6.10.8.3.7.1 Fire Suppression.**
- N (A)** Rooms containing stationary storage battery systems shall be protected by an automatic sprinkler system installed in accordance with Section 13.3 of NFPA 1 or an approved alternative suppression system.
- N (B)** Commodity classifications for specific technologies of storage batteries shall be in accordance with Chapter 5 of NFPA 13. [1:52.3.2.7.1.1]
- N 6.10.8.3.7.2 Smoke Detection.** An approved automatic smoke detection system shall be installed in rooms containing stationary storage battery systems in accordance with *NFPA 72*, and the required automatic smoke detection system shall be supervised by an approved central, proprietary, or remote station service or a local alarm that will give an audible signal at a constantly attended location.
- N 6.10.8.3.8 Thermal Runaway.** Where required by 6.10.8.3.9, a listed device or other approved method shall be provided to preclude, detect, and control thermal runaway. [1:52.3.2.10]
- N 6.10.8.3.9 Battery-Specific Protection.** Stationary storage battery systems shall comply with 6.10.8.2 through 6.10.8.3.8 and this section, as applicable. [1:52.3.2.11]
- N 6.10.8.3.9.1 Lithium-Ion Batteries.** Stationary storage battery systems utilizing lithium-ion batteries shall be provided with thermal runaway monitoring in accordance with 6.10.8.3.8.
- N 6.10.8.3.9.2 Sodium-Nickel Batteries.** Stationary storage battery systems utilizing sodium-nickel batteries shall be provided with thermal runaway monitoring in accordance with 6.10.8.3.8.
- N 6.10.8.3.10 Testing, Maintenance, and Repairs.**
- N 6.10.8.3.10.1** Stationary storage batteries and associated equipment and systems shall be tested and maintained in accordance with the manufacturer's instructions. [1:52.3.2.12.1]
- N 6.10.8.3.10.2** Any storage batteries or system components used to replace existing units shall be compatible with the battery charger, battery management systems, other storage batteries, and other safety systems. [1:52.3.2.12.2]
- N 6.10.8.4 Other Battery Types.** Other battery types not addressed in 6.10.8.2 or 6.10.8.3 shall be in accordance with Chapter 52 of NFPA 1.
- Δ 6.10.9\* Special Hazards.**
- 6.10.9.1\*** Where provided, alternative energy systems such as photovoltaic systems, fuel cells, microturbines, wind turbines, and similar energy source or storage systems shall comply with applicable codes and standards.
- 6.10.9.2** If installed in lightning-prone areas, the alternative energy installation shall comply with NFPA 780.
- 6.10.10 Smoke Management Systems.** Where smoke management systems are provided, they shall comply with Section 8.7.
- 6.11 Main Distribution Frame Areas.**
- 6.11.1\* General.** Main distribution frame areas shall be arranged to enhance the survivability of the main distribution frame equipment and adjacent signal-processing equipment in accordance with 6.11.2 through 6.11.11.
- 6.11.2 Construction.**
- 6.11.2.1 Floor/Ceiling Assemblies.** Floor/ceiling assemblies over main distribution frame areas shall be constructed to protect against the leakage of water from the roof or occupied areas above.
- 6.11.2.2 Raised Floors.**
- 6.11.2.2.1** Structural supporting members and decking for raised floors shall be of noncombustible material.
- 6.11.2.2.2** Access sections or panels shall be provided in raised floors so that all the space beneath is accessible.
- 6.11.2.2.3\*** Dedicated floor puller(s) shall be provided to gain access beneath the raised floor and located at every fire-fighting access route to raised floor areas.
- 6.11.2.2.4** Cable openings in floors shall be made smooth or shall be otherwise protected to preclude the possibility of damage to the cables.
- 6.11.2.2.5** The space beneath any raised floor shall not be used for storage.
- 6.11.2.2.6** Abandoned cables shall be removed provided that they can be removed without damaging adjacent cables and the building structure or finish.

**6.11.3\* Compartmentation.** Main distribution frame areas shall be separated from adjacent nontelecommunications equipment areas and standby engine areas by a minimum of 1-hour fire-resistance-rated construction in accordance with Sections 8.2 and 8.3.

#### 6.11.4 Building Services Equipment.

**6.11.4.1** Where building services equipment are provided, they shall be in accordance with Section 6.6.

**6.11.4.2\*** Building services equipment shall be limited to that needed to support the main distribution frame area and adjacent telecommunications equipment areas.

**6.11.4.3** Telecommunications facilities containing less than 232 m<sup>2</sup> (2500 ft<sup>2</sup>) of signal-processing equipment area(s) shall not be required to comply with the requirements of 6.6.1(1), 6.6.1(2), and 6.11.4.2.

#### 6.11.5 Main Distribution Frame (MDF) Equipment.

**6.11.5.1\*** The main distribution frame (MDF) area shall be classified as Level A or Level C in accordance with 8.8.3.

**6.11.5.1.1** All new MDF equipment, whether owned or co-located, shall be classified as Level A or Level C in accordance with 8.8.3.

**6.11.5.1.2** All new wires and cables, whether owned or co-located, shall be in accordance with 8.8.2.

**6.11.5.2\*** Wires, cables, and equipment shall be used in configurations and uses for which they have been tested and qualified.

**6.11.5.3** An MDF that complies with Level A of 8.8.3(1), and with wires and cables in accordance with 8.8.2, shall not require automatic fire suppression, smoke management, or separation from other MDF areas that comply with Level A of 8.8.3(1).

**6.11.5.4** An MDF that complies with Level A of 8.8.3(1), and with wires and cables in accordance with 8.8.2, shall not require automatic fire suppression, smoke management, or separation from signal-processing equipment that complies with Level A of 8.8.3(1).

**6.11.5.5** Facilities containing 232 m<sup>2</sup> (2500 ft<sup>2</sup>) of signal-processing equipment area, and containing an MDF consisting of significant components that do not comply with Level A of 8.8.3(1), or significant wires and cables that do not comply with 8.8.2, shall have an MDF area separated from other telecommunications equipment areas by 1-hour fire-resistance-rated construction, or the area shall be protected throughout by an automatic fire suppression system.

**6.11.5.6** Facilities containing 232 m<sup>2</sup> (2500 ft<sup>2</sup>) or less of signal-processing equipment area, and containing an MDF consisting of significant wires and cables that do not comply with 8.8.2, shall have main distribution area separated from the remainder of the telecommunications equipment area by either of the following:

- (1) Sufficient spatial separation and smoke management to prevent fire and smoke damage to telecommunications equipment other than the equipment of fire origin
- (2) A rated fire separation with a minimum fire resistance of 1 hour

#### 6.11.6 Fire Detection.

**6.11.6.1 General.** In telecommunications facilities containing greater than 232 m<sup>2</sup> (2500 ft<sup>2</sup>) of signal-processing equipment areas, the main distribution frame areas shall be provided with a very early warning fire detection (VEWFD) system for detection and alarm processing in accordance with Chapter 8.

**6.11.6.1.1** Raised floor areas that do not have a common airflow above and below the raised floor and contain combustibles below the raised floor shall be provided with an EWFD system below the raised floor.

**6.11.6.1.2** Where raised floor areas share common airflow above and below the raised floor, the VEWFD provided above the raised floor shall be considered adequate to protect the area below the raised floor.

**6.11.6.2 General.** In telecommunications facilities containing 232 m<sup>2</sup> (2500 ft<sup>2</sup>) or less of signal-processing equipment areas, the main distribution frame areas shall be provided with an EWFD system for detection and alarm processing in accordance with Chapter 8.

**6.11.6.2.1** Raised floor areas that contain combustibles below the raised floor shall be provided with an EWFD system below the raised floor regardless of common airflow.

**6.11.6.3 Installation, Testing, and Maintenance.** All fire alarm, detection, and alarm notification equipment shall be installed, tested, and maintained in accordance with *NFPA 72*.

#### 6.11.7 Fire Suppression.

**6.11.7.1 Portable Fire Extinguishers.** Main distribution frame areas shall be provided with listed portable fire extinguishers suitable for use on energized equipment in accordance with 8.6.3.

**6.11.7.2 Automatic Fire Suppression.** Where automatic fire suppression systems are provided, they shall be in accordance with 8.6.1 and 8.6.2.

**6.11.8 Limitation of Combustibles.** Main distribution frame areas shall not be used for the storage of combustible materials or other equipment not related to the main distribution frame operations.

**6.11.8.1** Limitations of combustible materials shall be in accordance with Chapter 9.

**6.11.9 Technical Support Areas.** Technical support areas in accordance with Section 6.13 shall be permitted.

**6.11.10 Special Hazards.** Heat-producing appliances not related to support of main distribution frame operations shall not be permitted.

**6.11.11 Smoke Management Systems.** Where smoke management systems are provided, they shall comply with Section 8.7.

#### 6.12 Standby Engine Areas.

**6.12.1 General.** Standby engine areas shall be arranged to prevent the spread of fire to adjacent areas and to reduce the hazards associated with the fuel supply for the generator in accordance with 6.12.2 through 6.12.10.



**6.12.2 Construction.** Where used, soundproofing shall be of noncombustible or limited-combustible materials.

**6.12.3 Compartmentation.**

**6.12.3.1\*** Standby engine areas shall be separated from adjacent areas by a minimum of 2-hour fire-resistance-rated construction in accordance with Sections 8.2 and 8.3, or for standby engine areas protected by automatic fire suppression systems, the fire resistance rating of the enclosure shall be permitted to be reduced to a minimum of 1 hour.

**6.12.3.2** Telecommunications facilities containing less than 232 m<sup>2</sup> (2500 ft<sup>2</sup>) of signal-processing equipment area shall have the standby engine area separated from other areas by a minimum of 1-hour fire-resistance-rated construction in accordance with Sections 8.2 and 8.3.

**6.12.4\* Fuel Control.**

**6.12.4.1** To limit fire spread and flashback, fuel supplies to standby engines shall be controlled by containment, by automatic fuel cutoffs in lines supplying the standby engine and any tanks in the compartment, and by control of effluent.

**6.12.4.2** Telecommunications facilities containing less than 232 m<sup>2</sup> (2500 ft<sup>2</sup>) of signal-processing equipment area(s) shall not be required to comply with 6.12.4.1.

**6.12.5\* Building Services Equipment.** Building services equipment shall be provided in accordance with Section 6.6 and shall be limited to that needed to support the area.

**6.12.6 Standby Engine Installation.** Standby engine installations shall comply with NFPA 30, NFPA 37, and NFPA 54, as applicable.

**6.12.7 Fire Detection.**

**6.12.7.1 General.** Standby engine installations shall be provided with a heat or flame detection system for detection and alarm processing in accordance with Chapter 8.

**6.12.7.2 Installation, Testing, and Maintenance.** All fire alarm, detection, and alarm notification equipment shall be installed, tested, and maintained in accordance with *NFPA 72*.

**6.12.8 Fire Suppression.**

**6.12.8.1 Portable Fire Extinguishers.** Standby engine areas shall be provided with listed portable extinguishers suitable for use on both energized equipment and expected liquid or gaseous fuel fires in accordance with 8.6.3.

**6.12.8.2 Automatic Fire Suppression.** Where automatic suppression systems are provided, they shall be in accordance with 8.6.1 and 8.6.2.

**6.12.9 Limitation of Combustibles.**

**6.12.9.1** Standby engine areas shall not be used for the storage of combustible materials or other equipment not related to standby engine operations.

**6.12.9.2** Limitations of combustible materials shall be in accordance with Chapter 9.

**6.12.10 Smoke Management Systems.** Where smoke management systems are used in standby engine areas, they shall comply with Section 8.7.

**6.13 Technical Support Areas.**

**6.13.1 General.**

**6.13.1.1** Technical support areas shall be arranged to enhance the survivability of the adjacent telecommunications equipment areas in accordance with 6.13.1.2 through 6.13.2.2.

**6.13.1.2** Small work areas shall be permitted within the signal-processing equipment, power, and main distribution frame areas if the following conditions are met:

- (1) Case furniture, including desks, is constructed of noncombustible material (e.g., metal). The construction can include a high-pressure laminate veneer on desktop.
- (2) Any paper records, manuals, and drawings are stored in fully enclosed noncombustible cabinets or cases.
- (3) Space dividers and system furniture panels and chairs with upholstered assemblies exhibit a maximum rate of heat release not exceeding 80 kW and a maximum total heat released not exceeding 25 MJ within the first 10 minutes of test when tested in accordance with one of the following:
  - (a) ASTM E1537
  - (b) California Technical Bulletin 133
- (4) Noncombustible containers are provided for combustible material.
- (5) The amount of records within the area are kept to the absolute minimum required for essential and efficient operation.
- (6) Only records that are essential to the operations are permitted to be kept in the area.

**6.13.2 Fire Protection Measures.**

**6.13.2.1** Technical support areas shall be provided with one of the following as applicable in accordance with Chapter 8 for detection and alarm processing:

- (1) Standard fire detection systems when they are not part of a telecommunications equipment area.
- (2) For telecommunications facilities containing greater than 232 m<sup>2</sup> (2500 ft<sup>2</sup>) of signal-processing area(s), technical support areas shall be provided with VEVFD systems when they are within the telecommunications signal-processing equipment and main distribution frame area.
- (3) For telecommunications facilities containing greater than 232 m<sup>2</sup> (2500 ft<sup>2</sup>) of signal-processing area(s), technical support areas shall be provided with EWFD systems when they are within the power area.
- (4) For telecommunications facilities containing less than 232 m<sup>2</sup> (2500 ft<sup>2</sup>) of signal-processing area(s), technical support areas shall be provided with EWFD systems when they are within the telecommunications equipment area.

**6.13.2.2** Portable fire extinguishers shall be provided in accordance with 8.6.3.

**6.13.2.3** Where automatic suppression systems are provided in technical support areas, they shall be in accordance with the requirements of 8.6.1 and 8.6.2.

**6.14 Administrative Areas.**

**6.14.1 General.** Administrative areas shall be arranged to prevent the spread of fire to adjacent telecommunications equipment areas in accordance with 6.14.2 through 6.14.5.

**6.14.2 Construction.**

**6.14.2.1** Where used, soundproofing shall be of noncombustible or limited-combustible materials.

**6.14.2.2** Floor assemblies over telecommunications equipment areas shall be constructed to protect against the penetration of water.

**6.14.3 Compartmentation.** Administrative areas shall be separated from adjacent telecommunications equipment areas by a minimum of 1-hour fire-resistance-rated construction in accordance with Sections 8.2 and 8.3.

**6.14.4 Fire Protection.** Administrative areas shall be protected by either a standard fire detection system or an automatic fire suppression system in accordance with Chapter 8.

**6.14.4.1 Fire Detection.**

**6.14.4.1.1** Where a fire detection system is provided, it shall be in accordance with the Chapter 8 requirements for detection and alarm processing.

**6.14.4.1.2 Installation, Testing, and Maintenance.** All fire alarm, detection, and alarm notification equipment shall be installed, tested, and maintained in accordance with *NFPA 72*.

**6.14.4.2 Fire Suppression.**

**6.14.4.2.1 Portable Fire Extinguishers.** Administrative areas shall be provided with listed portable extinguishers for use in accordance with 8.6.3.

**6.14.4.2.2 Automatic Fire Suppression.** Where automatic suppression systems are provided in administrative areas, they shall be in accordance with the requirements of 8.6.1 and 8.6.2.

**6.14.5 Cooking Areas.** Cooking areas shall be protected in accordance with *NFPA 96*.

**6.15 Building Service and Support Areas.**

**6.15.1 General.** Building service and support areas shall be arranged to enhance the survivability of the adjacent telecommunications equipment areas for continuity of service in accordance with 6.15.2 through 6.15.8.

**6.15.2 Construction.**

**6.15.2.1** Where used, soundproofing shall be of noncombustible or limited-combustible materials.

**6.15.2.2** Floor assemblies over telecommunications equipment areas shall be constructed to protect against the penetration of water.

**6.15.3 Compartmentation.**

**6.15.3.1** Telecommunications facilities containing greater than 232 m<sup>2</sup> (2500 ft<sup>2</sup>) of signal-processing equipment area shall have the building service and support areas separated from adjacent telecommunications equipment areas by a minimum of 2-hour fire-resistance-rated construction or by a minimum of 1-hour fire-resistance-rated construction where automatic fire suppression is provided within the building services and support area compartment(s).

**6.15.3.2** Telecommunications facilities containing less than 232 m<sup>2</sup> (2500 ft<sup>2</sup>) of signal-processing equipment area shall have the building service and support areas separated from

adjacent telecommunications equipment areas by a minimum of 1-hour fire-resistance-rated construction.

**6.15.3.3** Building services and support areas shall be separated from adjacent nontelecommunications equipment areas by a minimum of 1-hour fire-resistance-rated construction.

**6.15.3.4** All construction shall be in accordance with Sections 8.2 and 8.3.

**6.15.4 Fire Protection.** Building service and support areas shall be protected by either a standard fire detection system or an automatic fire suppression system.

**6.15.4.1 Fire Detection.**

**6.15.4.1.1** Where a fire detection system is provided, it shall be in accordance with the Chapter 8 requirements for detection and alarm processing.

**6.15.4.1.2 Installation, Testing, and Maintenance.** All fire alarm, detection, and alarm notification equipment shall be installed, tested, and maintained in accordance with *NFPA 72*.

**6.15.4.2 Fire Suppression.**

**6.15.4.2.1 Portable Fire Extinguishers.** Building services and support areas shall be provided with listed portable extinguishers for use in accordance with 8.6.3.

**6.15.4.2.2 Automatic Fire Suppression.** Where automatic suppression systems are provided in building services and support areas, they shall be in accordance with the requirements of 8.6.1 and 8.6.2.

**6.15.5 HVAC Systems.** An HVAC system(s) shall be installed in accordance with *NFPA 90A*.

**6.15.6 Electrical.** Nontelecommunications power circuits shall be installed in accordance with *NFPA 70*.

**6.15.7 Lightning and Surge Protection.** Lightning and surge protection, where provided, shall be installed in accordance with *NFPA 780* and *NFPA 70*, respectively.

**6.15.8 Special Hazards.** Flammable and combustible liquids and aerosols shall be stored in listed fire-rated storage cabinets.

**Chapter 7 Redundant or Replacement-Based Approaches**

**7.1\* Redundancy or Replacement Approach.** Where the performance-based approach of Chapter 5 or the prescriptive elements of Chapter 6 are not used, the requirements of this chapter shall apply.

**7.1.1 Application.** This chapter applies to telecommunications facilities or a hazard area within, for which service continuity is provided by the following:

- (1) Redundancy on site
- (2) Redundancy off site
- (3) Replacement

**7.1.1.1 Redundancy On Site.**

**7.1.1.1.1** The telecommunications owner/operator shall be permitted to provide complete functionally redundant equipment in the same facility with manual or automatic transfer of service.

**7.1.1.1.2** To ensure on-site service continuity when using the redundant on-site approach, the redundant equipment systems shall be physically separated using 1-hour fire-resistance-rated construction and a smoke management system shall be provided.

**7.1.1.2 Redundancy Off Site.** The telecommunications owner/operator shall be permitted to provide complete functionally redundant equipment at a remote facility with manual or automatic transfer of service.

**7.1.1.3 Replacement.** The telecommunications owner/operator shall be permitted to protect telecommunications service with replacement telecommunications equipment, facilities, or both where service can be quickly restored.

**7.1.2 Maintenance of Redundant or Replacement-Based Approach.** For the redundancy or replacement approach to continue to meet the performance goals and objectives of this standard, the selected approach shall be maintained for the life of the facility.

**7.2 Construction.** Where the replacement approach necessitates that the building survive a fire, the building construction shall be in accordance with Sections 8.2 and 8.3.

**7.3\* Protection from Exposures.** Exterior walls and openings shall be protected.

**7.4 Means of Egress.** Means of egress shall be provided in accordance with NFPA 101.

**7.5 Means for Depowering.** Telecommunications facilities containing more than 232 m<sup>2</sup> (2500 ft<sup>2</sup>) of signal-processing equipment areas shall be provided with a means for depowering in accordance with 7.5.1 through 7.5.3. (See Annex E.)

**7.5.1 General.** Signal-processing equipment area(s) shall be based on the total accumulated floor area within a telecommunications facility occupied by signal-processing equipment, including the access aisles between equipment and a 0.6 m (2 ft) wide access zone around the perimeter of each signal-processing equipment area.

**7.5.2** Means to disconnect power from building services equipment, power and lighting circuits, and telecommunications equipment shall be identified for incident intervention.

**7.5.3** Power distribution/disconnect equipment with appropriate marking shall be permitted to be used as a means to disconnect power.

## **7.6 Telecommunications Equipment Areas.**

**7.6.1 Emergency Lighting.** Emergency lighting shall be provided in the facility in accordance with NFPA 101.

**7.6.2\* Compartmentation.** Where administrative, building services and support, and standby engine areas are provided in the telecommunications facility, they shall be separated from telecommunications equipment areas by 1-hour fire-resistance-rated construction in accordance with Sections 8.2 and 8.3.

## **7.6.3 Telecommunications Equipment.**

**7.6.3.1** All new wire, cable, and signal-processing telecommunications equipment installed, whether owned or co-located, shall be in accordance with Section 8.8 for the type of wire, cables, and signal-processing telecommunications equipment.

**7.6.3.2\*** Signal-processing telecommunications equipment shall be industry standard compliant and shall be installed and used in configurations and uses for which it has been tested and qualified.

**7.6.3.3** Wire and cable that do not comply with the fire safety requirements of 8.8.2 shall be separated from the remainder of the telecommunications equipment area by either of the following:

- (1) Sufficient spatial separation and smoke management to prevent fire and smoke damage to equipment other than the equipment of fire origin
- (2) A rated fire separation with a minimum fire resistance of 1 hour

**7.6.3.4** Equipment that does not comply with the fire safety requirements of Level A of 8.8.3(1) shall be separated from the remainder of the telecommunications equipment area by either of the following:

- (1) Sufficient spatial separation and smoke management to prevent fire and smoke damage to equipment other than the equipment of fire origin
- (2) A rated fire separation with a minimum fire resistance of 1 hour

## **7.6.4 Fire Detection.**

**7.6.4.1** Where the replacement approach is adopted, areas within telecommunications facilities shall be provided with a standard fire detection system for detection and alarm processing in accordance with Chapter 8.

**7.6.4.2** Where the redundancy approach is used, a fire detection system shall be provided for detection and alarm processing in accordance with Chapters 6 and 8.

**7.6.4.3** Installation, testing, and maintenance shall be in accordance with NFPA 72.

## **7.6.5 Fire Suppression.**

**7.6.5.1 Portable Fire Extinguishers.** Portable extinguishers suitable for use on energized equipment and/or ordinary combustible fires shall be provided in accordance with 8.6.3.

**7.6.5.2 Automatic Fire Suppression.** Where automatic fire suppression systems are provided, they shall be in accordance with 8.6.1 and 8.6.2.

## **7.6.6 Limitation of Combustibles.**

**7.6.6.1** Telecommunications facilities shall not be utilized for the storage of combustible materials or other equipment not related to the switching and transmission of voice, data, and video signals.

**7.6.6.2** Limitations of combustible materials shall be in accordance with Chapter 9.

## **7.6.7 Special Hazards.**

**7.6.7.1** Hazardous operations, such as cutting and welding, shall not be conducted without special permits.

**7.6.7.2** Heat-producing appliances not related to the support of telecommunications equipment shall not be permitted within the area.

**7.6.8 Smoke Management.** Where smoke management systems are used, they shall comply with Section 8.7.

## 7.7 Building Services Equipment.

**7.7.1** Building services equipment shall be provided in accordance with Section 6.6.

**7.7.2\*** Building services equipment shall be limited to that needed to support the area and adjacent telecommunications equipment areas, excluding the standby engine area and cable entrance facility area.

**7.8 Emergency Lighting.** Emergency lighting shall be provided in the telecommunications facility in accordance with NFPA 101.

**7.8.1\*** Emergency lighting system shall be permitted to be powered by the telecommunications facility battery system.

**7.8.2\*** Where the telecommunications facility battery system is used to power the emergency lighting system, it shall have adequate reserves to meet the loads of the telecommunications equipment and the emergency lighting load connected for the minimum time required in accordance with NFPA 101.

## Chapter 8 Fire Protection Elements

**8.1 General.** Chapter 8 contains fire protection elements used to meet the prescriptive requirements of Chapters 6 and 7 and shall not be applied independently of Chapters 6 and 7.

### 8.2 Construction.

**8.2.1 Buildings.** Buildings housing telecommunications facilities shall be of noncombustible construction in accordance with NFPA 220.

**8.2.2 Interior Walls.** All interior walls shall be of noncombustible or limited-combustible construction.

### 8.2.3\* Aisle Containment Systems for Telecommunications Equipment.

**8.2.3.1\*** Aisle containment systems shall be permitted to be one of the following:

- (1) Factory-packaged — Systems designed, provided, and installed by the manufacturer of the telecommunications equipment
- (2) Field-installed — Aftermarket systems designed and provided by others and installed after the telecommunications equipment is in place

**8.2.3.2** Both types of aisle containment systems shall comply with 8.2.3.3 through 8.2.3.10.

**8.2.3.3** Elements of aisle containment and hot air collars shall be constructed of noncombustible materials, limited combustible materials, or materials that have a maximum flame spread index of 50 and a maximum smoke development of 450 in accordance with one or more of the following:

- (1) ASTM E84, *Standard Test Method for Surface Burning Characteristics of Building Materials*
- (2) ANSI/UL 723, *Standard for Test for Surface Burning Characteristics of Building Materials*.

**8.2.3.4\*** Aisle containment systems and hot air collars shall not be considered to be plenums.

**8.2.3.5** Aisle containment systems shall be permitted to be applied to hot aisles or cold aisles of telecommunications equipment.

**8.2.3.6\*** Spot-type smoke detectors within aisle containment systems shall be rated for the intended temperatures of hot aisles when installed in those locations.

**8.2.3.7\*** Where aisle containment systems are installed, the existing suppression and detection systems shall be evaluated to determine if it is necessary to modify them in order to maintain compliance with the applicable codes and standards.

**8.2.3.8** Where automatic sprinklers are present, and the application of aisle containment systems or hot air collars creates obstructions to proper operation of sprinkler systems, the sprinkler system shall be modified to comply with NFPA 13.

**8.2.3.8.1\*** Sprinkler system modifications shall not be required where all of the following conditions are met:

- (1)\* An automatic means of smoke detection initiates the removal of the obstruction prior to the suppression system operation.
- (2) Removing the obstruction or portion thereof does not compromise means of egress per NFPA 101.
- (3) The design and installation of removable obstruction elements comply with 1.4.1.1 and Section 1.6.
- (4)\* The releasing devices are listed for the application.
- (5) The obstructions are removed for the entire suppression zone, except where the requirements of 8.2.3.8 are met.

**8.2.3.9\*** Where gaseous suppression systems are present, they shall be designed to develop the required concentration of agent for the entire volume they serve in accordance with NFPA 2001.

**8.2.3.10** If the aisle containment prevents the gaseous suppression system, where present, from producing the required design concentrations throughout the entire volume served, the gaseous suppression system shall be modified to produce the required concentration throughout the volume served.

**8.2.3.10.1\*** Gaseous suppression system modifications shall not be required where all of the following conditions are met:

- (1)\* An automatic means of smoke detection initiates the removal of the obstruction prior to the suppression system operation.
- (2) Removing the obstruction or portion thereof does not compromise means of egress per NFPA 101.
- (3) The design and installation of removable obstruction elements comply with 1.4.1.1 and Section 1.6.
- (4)\* The releasing devices are listed for the application.
- (5) The obstructions are removed for the entire suppression zone, except where requirements of 8.2.3.10 are met.

**8.2.3.10.2** Ceiling cavity and raised floor plenums shall be included as part of the protected volume where the following conditions apply:

- (1) Hot air collars are connected to a ceiling plenum.
- (2) Telecommunications equipment continues to operate during system discharge.

**8.2.3.11** Where factory-packaged aisle containment systems are provided for telecommunications equipment aisles, they shall be installed in accordance with the manufacturer's instructions and listings.

**8.3\* Compartmentation.** The telecommunications facility shall be separated from other occupancies within the building by fire-resistance-rated construction, which is commensurate with the exposure but not less than 1 hour.

**8.3.1 Fire-Resistance-Rated Construction.** Where required elsewhere in this document, fire-resistance-rated construction shall be provided around designated areas.

**8.3.1.1** The fire resistance rating of the assembly shall correspond to the highest rating required for the separated areas.

**8.3.1.2** Fire-resistance-rated partitions shall extend from the foundation or floor below to the underside of the roof or floor deck above to provide a complete separation.

**8.3.2 Protection of Fire-Resistance-Rated Construction Openings.**

**8.3.2.1 Doors.** Doors shall be fire tested under positive pressure to NFPA 252 and shall be installed in accordance with NFPA 80.

**8.3.2.1.1** The fire rating of the door assemblies shall correspond to the fire rating of the partition assemblies, as follows:

- (1) One-hour partition shall have 1-hour fire-resistance-rated door assembly.
- (2) Two-hour partition shall have 1½-hour fire-resistance-rated door assembly.
- (3) Three-hour partition shall have 3-hour fire-resistance-rated door assembly.

**8.3.2.1.2** Doors shall be self-closing or automatic-closing upon designated alarm signal activation.

**8.3.2.2 Glazing Materials in Doors.** Glazing materials in doors shall be fire tested under positive pressure to NFPA 252 and shall be installed in accordance with NFPA 80.

**8.3.2.3 Glazing Materials in Fire-Resistance-Rated Construction.** Glazing materials in fire-resistance-rated walls shall have an equal fire resistance rating as the wall or be protected with an automatic fire-resistance-rated shutter in accordance with NFPA 80.

**8.3.2.3.1** The fire-resistance-rated glazing material shall be fire tested to NFPA 257.

**8.3.2.3.2** The fire-resistance-rated glazing material shall be listed and labeled.

**8.3.2.4 Construction Joints.**

**8.3.2.4.1** Joints in or between walls and floor/ceiling assemblies of fire-resistance-rated construction shall be fire tested in accordance with ASTM E1966.

**8.3.2.4.2** The fire-resistance-rated joint systems shall be listed.

**8.3.3 Penetrations in Fire-Resistance-Rated Construction.**

**8.3.3.1 Pipes, Conduits, Cables, and Cable Trays.**

**8.3.3.1.1** Pipes, conduits, cables, and cable trays that penetrate fire-resistance-rated construction shall be protected with assemblies tested in accordance with ASTM E814.

**8.3.3.1.2** The penetration firestop systems shall be listed.

**8.3.3.2 HVAC Systems.** Fire dampers, smoke dampers, or combination fire/smoke dampers shall be installed to protect penetrations of fire-resistance-rated walls, floor/ceiling assemblies, and smoke barriers created by HVAC system elements in accordance with NFPA 90A.

**8.3.3.2.1** Combination fire/smoke dampers in the affected area shall be automatically activated by a smoke detection

system installed throughout the area or by duct smoke detectors installed in the duct adjacent to the dampers.

**8.3.3.2.2** The annular space around the HVAC system ductwork through fire-resistance-rated construction and smoke barriers shall be protected with a listed firestop system in accordance with ASTM E814.

**8.4 Alarm Processing.**

**8.4.1 General.**

**8.4.1.1\*** Alarm processing described in Section 8.4 shall be provided.

**8.4.1.2** Fire alarm, supervisory, and trouble signals shall be annunciated at a constantly attended location.

**8.4.1.3\*** Use of VEWFD systems with an alert (pre-alarm) condition shall provide for an initial response by authorized personnel prior to fire department notification.

**8.4.1.3.1** The initial response shall be by owner-designated personnel such as a telecommunications facilities person or technician.

**8.4.1.4** Alarm monitoring centers maintained by the telecommunications service provider meeting the requirements of 8.4.1.5 shall be permitted to be the supervising station.

**8.4.1.5** Supervising stations meeting the requirements of *NFPA 72* for proprietary or central station service shall be acceptable supervising stations.

**8.4.2 Signaling.** Fire alarm control units shall provide for receipt and processing of signals for transmission to an approved supervising station.

**8.4.2.1 Fire Alarm Signals.**

**8.4.2.1.1** Disposition of fire alarm signals shall conform to the requirements of *NFPA 72*.

**8.4.2.1.2** Manual fire alarm signals shall be initiated by manual pull stations.

**8.4.2.1.3** Automatic fire alarm signals shall be initiated by, but not be limited to, the following:

- (1) Smoke detectors
- (2) Heat detectors
- (3) Flame detectors
- (4) Suppression system release
- (5) Waterflow initiating devices

**8.4.2.1.4** Fire alarm signals shall take precedence in processing over all other signals.

**8.4.2.1.5** The automatic or manual initiation of alarm conditions shall cause the building fire alarm notification appliances to operate in accordance with the requirements of *NFPA 72*.

**8.4.2.1.6** Fire alarm signals shall be automatically and immediately transmitted to a constantly attended supervising station.

**8.4.2.1.7** The supervising station shall immediately notify the local fire service of any fire alarm signal and, in addition, shall provide the fire service with information as to the site location and any special conditions that could exist.

**8.4.2.1.8** Designated telecommunications personnel shall be dispatched to the site immediately upon receipt of alarm.

**8.4.2.1.9** The fire alarm system shall be restored to its normal operating condition as soon as possible after the disposition of the cause of the alarm signal.

#### **8.4.2.2 Supervisory Signals.**

**8.4.2.2.1** Disposition of supervisory signals shall conform to the requirements of *NFPA 72*.

**8.4.2.2.2\*** Supervisory signals shall be given priority over all other general building maintenance alarm signals.

**8.4.2.2.3** Supervisory signals shall be immediately transmitted to a supervising station.

**8.4.2.2.4** Supervisory signals shall include, but not be limited to, the following:

- (1) Alert signal (pre-alarm) from a VEWFD system
- (2) Fire alarm initiating devices, where designated as such (e.g., duct smoke detectors)
- (3) Sprinkler valve supervisory switches
- (4) Fire pump off-normal conditions
- (5) Other abnormal fire safety-related conditions

**8.4.2.2.5\*** Where provided, hydrogen gas danger level, methane gas danger level, battery room ventilation fan failure, and similar off-normal conditions of safety-related items shall be transmitted as supervisory signals to the supervising station described in 8.4.1.5 or the alarm monitoring center described in 8.4.1.4.

**8.4.2.2.5.1** The signal shall also be permitted to be displayed on the local fire alarm system as a supervisory signal.

**8.4.2.2.6** Where hydrogen gas danger level, methane gas danger level, or battery room ventilation fan failure monitoring is provided, and the off-normal condition represents a potential danger to on-site personnel, it shall initiate a local audible and visible warning signal to alert occupants in the area of danger.

**8.4.2.2.7** The alert pre-alarm signal from a VEWFD system shall be distinguishable from all other fire alarm, supervisory, and trouble signals.

**8.4.2.2.8** Where required, the supervisory station operator shall initiate the following actions upon receipt of a supervisory signal:

- (1) Communicate immediately with the designated person(s) to ascertain the reason for the signal
- (2) Investigate, unless supervisory conditions are promptly restored to normal
- (3) Notify the fire department
- (4) Notify the authority having jurisdiction when the fire protection systems are wholly or partially out of service for 8 hours or more
- (5) Provide written notice to the authority having jurisdiction as to the nature of the signal, time of occurrence, and restoration of service, when telecommunications equipment has been out of service for 8 hours or more

**8.4.2.2.9** Supervisory signals shall not cause activation of building fire alarm notification appliances.

#### **8.4.2.3 Trouble Signals.**

**8.4.2.3.1** Disposition of fire alarm system trouble signals shall conform to the requirements of *NFPA 72*.

**8.4.2.3.2** Trouble signals shall include, but not be limited to, the following:

- (1) Ground fault condition
- (2) Open or short circuit fault
- (3) Loss of primary power
- (4) Fire alarm system component failure
- (5) Alarm transmitter failure
- (6) Microprocessor failure

**8.4.2.3.3\*** Trouble signals shall be responded to in accordance with *NFPA 72*.

**8.4.2.3.4** Where required, notification of trouble conditions to the local fire department shall be provided.

**8.4.2.3.4.1** Where monitoring systems provide the supervising station with detailed trouble information that allows determination of the degree of system impairment, response shall be permitted to be delayed until the next working day where it is determined that the trouble does not affect the ability to detect and report a fire condition.

**8.4.3 Signal Path Integrity.** Wiring between the fire alarm control unit and the telecommunications equipment that processes the signals to be sent to the supervising station shall be monitored for integrity such that an open, shorted, or ground fault condition on any conductor(s) shall cause a trouble signal to be indicated at a supervising station.

**8.4.3.1** Systems using a method of switching ground in normal operation shall not cause a trouble indication upon grounded condition.

**8.4.3.2** The requirements of 8.4.3 shall not apply where the distance between the fire control unit and the telecommunications equipment that processes the signal to be sent to the supervising station is no more than 0.9 m (3 ft).

**8.4.3.3** The requirements of 8.4.3 shall not apply where the primary notification location for alarm, supervisory, and trouble signals is an approved supervising station and the monitoring is accomplished in accordance with the requirements of *NFPA 72*.

## **8.5 Fire Detection.**

### **8.5.1 General.**

**8.5.1.1** Fire detection systems shall be designed, installed, and maintained to provide the level of protection required in Chapters 6 and 7.

**8.5.1.2** The levels of protection shall be as follows:

- (1) VEWFD (very early warning fire detection)
- (2) EWFD (early warning fire detection)
- (3) SFD (standard fire detection)

**8.5.2 Detection Systems.** VEWFD and EWFD smoke detection systems shall use spot-type smoke detectors or ports with spacing in accordance with 8.5.3.1 (VEWFD) and 8.5.3.2 (EWFD).

### **8.5.3 Installation.**

#### **8.5.3.1 VEWFD.**

**8.5.3.1.1** Where required by Chapters 6 and 7, VEWFD systems shall be in accordance with 8.5.3.1.2 through 8.5.3.1.2.6.

### 8.5.3.1.2 VEWFD Spot-type Smoke Detector and Port Installation.

**8.5.3.1.2.1\*** Where one level of spot-type smoke detectors or ports is installed in an area, it shall be limited to a maximum coverage area of 18.6 m<sup>2</sup> (200 ft<sup>2</sup>).

**8.5.3.1.2.2\*** Where two levels (high and low) of ports or spot-type smoke detectors are provided, the following requirements shall be met:

- (1) Each level shall be limited to a coverage of 37.2 m<sup>2</sup> (400 ft<sup>2</sup>) or less per port or spot-type smoke detector.
- (2) The coverage limitation between high and low levels shall be limited to 18.6 m<sup>2</sup> (200 ft<sup>2</sup>) or less providing for staggered port or spot-type smoke detector arrangements between each level.

**8.5.3.1.2.3\*** Spot-type smoke detectors or ports shall be installed to monitor air returning and leaving the space.

**(A)\*** Where stand-alone packaged HVAC units are installed, spot-type smoke detectors or ports shall be installed where return air is brought back to the unit at a point prior to filtration.

**N (B)\*** Spot-type smoke detectors or ports shall be installed to monitor all HVAC forced air leaving the space.

**(C)** Spot-type smoke detectors or ports at return air openings shall be installed such that each covers no greater than 0.4 m<sup>2</sup> (4 ft<sup>2</sup>) of the return air opening.

**N (D)** Spot-type smoke detectors or ports within return air ducts shall be installed such that each covers an area no greater than that specified in manufacturers' published instructions.

**8.5.3.1.2.4\*** Where air-sampling systems are installed, the systems shall be designed using manufacturer-provided listed criteria.

**8.5.3.1.2.5\*** Minimum sensitivity settings above ambient airborne levels for the VEWFD systems installed shall be as follows:

- (1) Alert condition includes the following:
  - (a) Air-sampling systems: 0.65 percent per meter (0.2 percent per foot) obscuration (effective sensitivity at each port)
  - (b) Spot-type smoke detectors: 0.65 percent per meter (0.2 percent per foot) obscuration
- (2) Alarm condition includes the following:
  - (a) Air-sampling systems: 3.2 percent per meter (1.0 percent per foot) obscuration (effective sensitivity at each port)
  - (b) Spot-type smoke detectors: 3.2 percent per meter (1.0 percent per foot) obscuration

**8.5.3.1.2.6** Maximum transport time from the most remote port, excluding test ports installed in the pipe network solely for the purpose of validating consistency in performance, to the detection unit of an air-sampling system shall not exceed 60 seconds.

### 8.5.3.2 EWFD.

#### 8.5.3.2.1 Smoke Detection Systems.

**8.5.3.2.1.1** Where required by Chapters 6 and 7, EWFD systems shall be in accordance with 8.5.3.2.1.2 through 8.5.3.2.1.5.

**8.5.3.2.1.2\*** The area of coverage for a single spot-type smoke detector or port shall be limited to a maximum coverage area of 37.2 m<sup>2</sup> (400 ft<sup>2</sup>).

**8.5.3.2.1.3** The minimum alarm sensitivity setting at the spot-type smoke detector or port used for EWFD in telecommunications equipment areas shall be 5.0 percent per meter (1.5 percent per foot).

**8.5.3.2.1.4** Maximum transport time from the most remote port, excluding test ports installed in the pipe network solely for the purpose of validating consistency in performance, to the detection unit of an air-sampling system shall be a maximum of 90 seconds.

**8.5.3.2.1.5\*** Where air-sampling systems are installed, the systems shall be designed using manufacturer-provided listed criteria.

#### 8.5.3.2.2 Flame Detection Systems.

**8.5.3.2.2.1** Where required by Chapters 6 and 7, flame detection systems shall be installed in accordance with this subparagraph.

**8.5.3.2.2.2\*** Flame detection systems shall be installed to provide line-of-sight detection for critical areas of the area.

**8.5.3.3 SFD.** Where required by Chapters 6 and 7, SFD systems shall comply with the requirements of *NFPA 72*.

### Δ 8.5.3.4 In-Cabinet Detection.

#### N 8.5.3.4.1 General.

**N 8.5.3.4.1.1\*** Where used, in-cabinet detection shall either be spot-type detectors or air-sampling-type detectors.

**N 8.5.3.4.1.2** Where detection is used for monitoring fire in individual cabinets, the following shall be met:

- (1) Spot-type smoke detectors or sampling ports shall be located in the main airflow at the exhaust vents, downstream of the airflow distribution path, or in accordance with the manufacturer's published instructions.
- (2) Multiple spot-type smoke detectors or ports shall be provided for cabinets having multiple outlet vents.
- (3) Where the cabinet is sealed and cooled by means other than airflow, spot-type smoke detectors or ports, when installed, shall be located within the cabinet in accordance with the manufacturer's published instructions.
- (4) If the cabinet is compartmentalized, each compartment shall have a spot-type smoke detector or port.
- (5) Where cabinets are fitted with in-cabinet suppression systems, the detection system shall provide an alarm signal for each cabinet or group of cabinets if the suppression system is to be released into several cabinets simultaneously.
- (6) Inspection, test, and maintenance shall be in accordance with the manufacturer's published instructions.

## 8.6 Fire-Extinguishing Systems.

**8.6.1\* General.** Where provided, fire suppression systems shall comply with 8.6.2.

### 8.6.2 Automatic Fire Suppression.

#### 8.6.2.1 General.

**8.6.2.1.1\*** Where provided, automatic fire suppression systems in telecommunications facilities shall comply with 8.6.2.1.2 through 8.6.2.5.3.

**8.6.2.1.2** Activation of any fire suppression system shall transmit an alarm immediately to a constantly attended location.

#### 8.6.2.2 Sprinkler Systems.

**8.6.2.2.1\*** Where provided, sprinkler systems shall be designed and installed in accordance with the requirements of NFPA 13, and tested and maintained in accordance with the requirements of NFPA 25.

**8.6.2.2.2** All piping for dry pipe and pre-action sprinkler systems shall be installed with a pitch in accordance with NFPA 13 whether or not the piping is subjected to freezing conditions.

**8.6.2.2.3** Detection systems installed to actuate pre-action sprinkler systems shall be installed in accordance with Section 8.5.

#### 8.6.2.3 Clean Agents.

**8.6.2.3.1\*** Where provided, clean agent extinguishing systems shall be designed, installed, and maintained in accordance with the requirements of NFPA 2001.

**8.6.2.3.2** Detection systems installed to actuate clean agent suppression systems shall be designed in accordance with Section 8.5.

**8.6.2.3.3** Cross-zoned detection or an equivalent method shall be used to minimize the potential of false discharges.

#### 8.6.2.4 Halon Systems.

**8.6.2.4.1\*** Where provided, halon systems shall be designed, installed, and maintained in accordance with NFPA 12A.

**8.6.2.4.2** Detection systems used to actuate halon suppression systems shall be designed in accordance with Section 8.5.

**8.6.2.4.3** Detection shall be either cross-zoned or an equivalent method shall be used to minimize the potential of false discharges.

#### 8.6.2.5 Water Mist Fire Protection Systems.

**8.6.2.5.1** Where provided, water mist fire protection systems shall be installed in accordance with the requirements of NFPA 750 and tested and maintained in accordance with the requirements of NFPA 25.

**8.6.2.5.2** Water mist fire protection systems shall be designed and installed for the specific hazards and protection objectives specified in the listing.

**8.6.2.5.3** Detection systems utilized for the operation of water mist fire protection systems shall be installed in accordance with Section 8.5 or the listing criteria.

### 8.6.2.6 In-Cabinet Suppression. (Reserved.)

### 8.6.3 Manual Fire Suppression.

#### 8.6.3.1 Portable Fire Extinguishers.

**8.6.3.1.1** The selection, placement, and maintenance of portable fire extinguishers shall be in accordance with NFPA 10.

**8.6.3.1.2** Where required, listed portable extinguishers suitable for use on energized telecommunications equipment shall be provided.

**8.6.3.1.3\*** Dry chemical and corrosive liquid agent portable fire extinguishers shall not be installed in signal-processing equipment areas, main distribution frame areas, and power areas.

**8.6.3.2\* Standpipes.** Where standpipes are provided, they shall be installed and maintained in accordance with NFPA 14.

## 8.7 Smoke Management Systems.

**8.7.1\* General.** Where provided, smoke management systems shall comply with 8.7.2 through 8.7.4.2. (*See Annex D.*)

**8.7.2\* Design and Installation.** Where provided, smoke management systems shall be designed, installed, and acceptance tested in accordance with accepted engineering practice.

**8.7.2.1** Operation of the smoke management system installed in the signal-processing equipment area, cable entrance facility area, power area, main distribution frame area, or standby engine area shall be automatically activated or manually activated from a location outside of the area.

**8.7.2.2\*** Where mechanical exhaust systems are installed, a source of make-up air shall be provided.

**8.7.2.3\*** Exhaust points shall be used to reduce the possibility of smoke being drawn into noninvolved telecommunications equipment.

**8.7.2.4** The smoke exhaust shall discharge to the outside of the building, away from fresh air intakes, make-up air intakes, and building openings.

**8.7.2.5\*** All operational components of the smoke management system shall be tested annually to verify their operation.

**8.7.3\* Smoke Removal.** Provision shall be made for the removal or purging of smoke from areas outside of smoke management zones.

**8.7.4 Power Supply.** The smoke management system shall be powered from a source protected against accidental depowering.

**8.7.4.1 Loss of Power or Control Signal.** The loss of power or control signal shall cause the closure of the smoke management system dampers.

**8.7.4.2\* Manual Override.** A means of manual override of the smoke management system shall be provided.

## 8.8 Telecommunications Equipment Ignition and Fire Performance.

**8.8.1\* General.** Where needed to achieve an objective of a performance-based design permitted by Chapter 5 or to meet the prescriptive requirements permitted by Chapters 6 and 7, the telecommunications equipment, cables, wiring, and associ-



ated components shall comply with the provisions of Section 8.8.

### 8.8.2 Wire and Cables.

**8.8.2.1** Telecommunications cables shall be listed to the requirements of ANSI/UL 444.

**8.8.2.2** Telecommunications wires shall be listed to the requirements for cross-connect wire in ANSI/UL 444.

**8.8.2.3** Optical fiber cables shall be listed to the requirements of ANSI/UL 1651.

**8.8.2.4** Wires and cables intended for powering signal-processing equipment and insulated ground wires shall be listed to the requirements of ANSI/UL 1277, ANSI/UL 44, or ANSI/UL 83 or shall be specifically listed for the purpose.

**8.8.2.5** Communications raceways shall be listed to the requirements of ANSI/UL 2024.

**8.8.2.6** Cable routing assemblies shall be listed to the requirements of ANSI/UL 2024.

**8.8.2.7** Nonmetallic cable trays shall be listed to the requirements of ANSI/UL 568.

### 8.8.2.8 Raised Floor and Ceiling Cavity Plenums.

**8.8.2.8.1** Wires and cables intended for powering signal-processing equipment, telecommunications cables, optical fiber cables, and insulated ground wires installed in plenums shall be listed as having a maximum flame spread of 1.5 m (5.0 ft) or less, a maximum peak optical density of 0.50 or less, and a maximum average optical density of 0.15 or less when tested in accordance with NFPA 262.

**8.8.2.8.2** Communications raceways installed in plenums shall be listed as having a maximum flame spread of 1.5 m (5.0 ft) or less, a maximum peak optical density of 0.50 or less, and a maximum average optical density of 0.15 or less when tested in accordance with ANSI/UL 2024, *Cable Routing Assemblies and Communications Raceways*.

**8.8.2.8.3** Cable routing assemblies shall be listed to the requirements of ANSI/UL 2024.

**8.8.2.8.4\*** Nonmetallic cable trays used in plenums shall be listed for use in plenums and shall be constructed of materials that are either noncombustible or that exhibit a maximum flame spread index of 25 and a maximum smoke developed index of 50 when tested in accordance with ASTM E84, *Standard Test Method for Surface Burning Characteristics of Building Materials*, or with ANSI/UL 723, *Standard for Test for Surface Burning Characteristics of Building Materials*.

### 8.8.2.9 Risers.

**8.8.2.9.1** Telecommunications cables, optical fiber cables, wires and cables intended for powering signal-processing equipment, insulated ground wires, communications raceways, and nonmetallic cable trays installed vertically between floors in a building shall comply with ANSI/UL 1666. These cables shall demonstrate limited smoke generation by testing in accordance with ANSI/UL 1685.

**8.8.2.9.2** Telecommunications cables, optical fiber cables, wires and cables intended for powering signal-processing equipment, and insulated ground wires meeting the requirements of 8.8.2.8.1 shall be permitted.

**8.8.2.9.3** Communications raceways meeting the requirements of 8.8.2.8.2 shall be permitted.

**8.8.2.9.4** Cable routing assemblies meeting the requirements of 8.8.2.8.3 shall be permitted.

**8.8.2.9.5** Cable routing assemblies shall be listed to the requirements of ANSI/UL 2024.

**8.8.2.9.6** Cable routing assemblies meeting the requirements of 8.8.2.8.4 shall be permitted.

**8.8.2.10 Installations Other Than Risers and Plenums.** Installations of telecommunications wires and cables, optical fiber cables, wires and cables intended for powering signal-processing equipment, and insulated ground wires in spaces other than risers or plenums shall comply with 8.8.2.10.1 or 8.8.2.10.2 or 8.8.2.10.3.

**8.8.2.10.1** Telecommunications wires and cables, optical fiber cables, wires and cables intended for powering signal-processing equipment, and insulated ground wires shall be listed as not spreading fire to the top of the tray and shall demonstrate limited smoke generation in the vertical-tray flame test in ANSI/UL 1685.

**8.8.2.10.2** Telecommunications wires and cables, optical fiber cables, wires and cables intended for powering signal-processing equipment, and insulated ground wires shall be listed as meeting the requirements of the FT-4 test in CSA Vertical Flame Test — Cables in Cable Trays in the *Test Methods for Electrical Wires and Cables*, C22.2 No. 0.3-M-1996, with char length not to exceed 1.5 m (4 ft 11 in.). These cables shall demonstrate limited smoke generation by testing in accordance with ANSI/UL 1685.

**8.8.2.10.3** Telecommunications cables, optical fiber cables, wires and cables intended for powering signal-processing equipment, and insulated ground wires meeting the requirements of 8.8.2.8.1 or 8.8.2.9.1 shall be permitted.

**8.8.2.10.4** Communications raceways shall not spread fire to the top of the tray in the vertical-tray flame test in ANSI/UL 2024.

**8.8.2.10.5** Cable routing assemblies shall be listed to the requirements of ANSI/UL 2024.

**8.8.2.10.6** Cable routing assemblies and communications raceways meeting the requirements of 8.8.2.8.2 or 8.8.2.9.1 shall be permitted.

**8.8.2.10.7** Cable routing assemblies meeting the requirements of 8.8.2.8.4 or 8.8.2.9.5 shall be permitted.

**8.8.3\* Major Telecommunications Equipment Systems.** Major telecommunications equipment shall be classified as follows:

- (1) *Level A.* Equipment that meets the fire resistance criteria specified in Telcordia GR-63-CORE, following the methodologies specified in ATIS 0600307 and ATIS 0600319
- (2) *Level B.* Equipment that meets the requirements of ANSI/UL 60950-1 only, and does not qualify for Level A classification
- (3) *Level C.* Equipment that does not meet the requirements of either Level A or Level B

**8.8.4 Nonlabeled Wire, Cable, and Telecommunications Equipment.** Where wire, cable, and telecommunications equipment are not labeled to indicate compliance with the requirements

of Section 8.8, the documentation regarding compliance with the fire resistance criteria specified in Section 8.8 shall be readily available.

## Chapter 9 Fire Prevention

### 9.1\* Housekeeping.

**Δ 9.1.1\* Removal or Storage of Combustibles.** Combustibles shall be removed from telecommunications equipment areas or shall be stored appropriately in protected storage rooms, noncombustible enclosed storage cabinets or bins, approved noncombustible refuse containers, or listed self-extinguishing-type trash receptacles.

### 9.1.2\* Limiting Other Combustibles.

**9.1.2.1** Combustible materials, such as packing materials and office supplies, shall not be stored in areas exposing critical telecommunications equipment and related components unless these materials are located in noncombustible cabinets or are within nontelecommunications equipment areas provided with fire suppression systems.

**9.1.2.2** Areas around the outside of the facility shall be free of combustibles.

**9.1.3\* Portable Heating Appliances.** Portable heaters shall not be permitted except where temporarily permitted by the building management.

**9.1.4\* Heat-Producing Appliances.** Portable heat-producing appliances shall not be used in any telecommunications equipment area, computer room, individual office area, individual office cubicle, storage area, or shipping area.

**9.1.4.1** The use of portable heat-producing tools necessary for installation and maintenance activities within the telecommunications facility shall be permitted.

**9.1.5\* Smoking.** Smoking, carrying, or depositing any lighted or smoldering substance shall not be permitted in telecommunications equipment and building support areas and all additional areas identified by local management as a risk to the network operation.

**■ 9.1.5.1 Vaporizing E-Cigarettes.** Use of vaporizing e-cigarettes shall not be permitted in the telecommunications equipment and building support areas and all additional areas identified by local management as a risk to the network operation.

**9.1.5.2\* Designated Smoking Areas.** If a designated smoking area is to be allowed in other areas of the building, local management shall conduct a fire risk analysis prior to designating such areas.

### 9.1.5.3 Signage.

**9.1.5.3.1** In buildings where smoking is prohibited, signs shall be posted at the entrances to the building.

**9.1.5.3.2** If smoking is permitted only in designated areas, signs shall be posted at the entrances of the building and at the designated area that state, "Smoking permitted only in the designated smoking area."

**9.1.5.3.3** In buildings where smoking is permitted, "No Smoking" signs shall be posted in conspicuous designated locations where smoking is prohibited.

### 9.1.6\* Hot Work.

**9.1.6.1** Prior to conducting hot work, a hot work permit shall be acquired.

**9.1.6.2** The hot work permit shall comply with Chapter 9 and NFPA 51B for areas not designed for this type of operation.

### 9.1.7\* Flammable and Combustible Liquids and Gases.

**9.1.7.1** The storage, handling, and use of flammable and combustible liquids, including waste liquids, shall comply with the requirements of NFPA 30.

**9.1.7.2** All flammable and combustible liquids shall be stored in approved fire-rated cabinets at the end of each shift.

**9.1.7.3\*** Propane stored in cylinders and containers on the exterior of the telecommunications facility shall comply with NFPA 54, NFPA 58, and NFPA 51B.

**9.1.7.4** Combustible gas storage within the telecommunications equipment area shall not be permitted except in the standby engine area.

**9.1.8 Clear Access.** Clear and unobstructed access to telecommunications facilities shall be maintained for fire and EMS operations.

**9.2\* Telecommunications Electrical Equipment and Wiring.** Telecommunications equipment under the exclusive control of one or more telecommunications utilities located outdoors or in building spaces used exclusively for such installation shall not be required to be installed in accordance with *NFPA 70*.

### 9.3 Nontelecommunications Electrical Equipment and Wiring.

**9.3.1** The installation and maintenance of nontelecommunications-related electrical equipment and wiring, such as the use of listed electrical fittings, materials, and equipment, shall be in accordance with *NFPA 70*.

### 9.3.2\* Electrical Cords.

**9.3.2.1** Electrical extension cords shall be used only when a flexible, temporary connection is necessary, and never for permanent wiring.

**9.3.2.2** Flexible electrical cords shall be adequate to carry the anticipated current and shall be listed.

**9.3.2.3** Cords shall not be permitted under carpets, rugs, or chair mats.

**9.4\* Construction, Alterations, and Equipment Installations.** All construction and alteration projects shall comply with NFPA 241 or an equivalent standard.

**9.4.1 Staging Areas.** Staging areas assigned for crating, dewatering, and containment of combustibles for telecommunications equipment installation and removal shall be designed with appropriate detection or separation or both and managed so as not to lower the overall level of fire safety within the telecommunications building.

**9.4.2 Cutting and Welding Activities.** Cutting and welding activities shall comply with 9.1.6, and portable fire extinguishers shall be provided and shall comply with 8.6.3.1.

**9.4.3\* Use and Storage of Combustible Materials.** Combustible materials for construction and installation that directly

support telecommunications equipment installation shall not exceed a 7-day supply in telecommunications equipment areas.

**9.4.4\* Building Construction and Alteration Work.** The delivery, storage, construction, and cleanup associated with building construction and alteration work shall be performed in accordance with NFPA 241.

**9.4.4.1** In buildings under construction, renovation, or alteration, adequate escape facilities shall be maintained at all times for the use of construction workers.

**9.4.4.2** Escape facilities shall consist of doors, walkways, stairs, ramps, fire escapes, ladders, or other approved means or devices arranged in accordance with NFPA 101.

**9.4.5 Bus Bar Protection During Construction Work.** Provisions shall be provided to protect the bus bars when building construction activity occurs in the area around or over live bus bars.

**9.4.6\* Fire Prevention Awareness for Contractors.**

**9.4.6.1** Telecommunications companies shall provide awareness information to contractors of fire prevention and protection issues or measures within telecommunications facilities.

**9.4.6.2** Contractors shall disseminate this information to all of their employees and their contractors working at the facility prior to commencement of work.

**9.5 Employee Awareness.** All employees of the facility shall be provided information regarding fire prevention policies, procedures, and fire safety hazards.

**9.6 Means of Egress.** All means of egress shall be maintained in accordance with the requirements of NFPA 101.

**9.7 Displays and Decorations.** Displays, holiday trees, or other decorations shall not be allowed in telecommunications equipment areas.

**9.8\* Cable Management.** The management of telecommunications and power cables shall be based on the consideration of potential fuel load and hazards within any given telecommunications equipment area or hazard area.

**9.8.1\*** For new cable distribution installations, ac, dc, and telecommunications cable shall be run in separate paths and not mixed.

**9.8.2** Points or tips of metal horns and other protruding devices on cable racks and ladders shall be insulated from the cables.

**9.8.3\*** Abandoned cables shall be removed provided that they can be removed without damaging adjacent cables and the building structure or finish.

## Chapter 10 Pre-Fire Planning, Damage Control, and Emergency Recovery

### 10.1 General

**10.1.1 Pre-Fire Plan.** Management of each telecommunications facility containing more than 9290 m<sup>2</sup> (100,000 ft<sup>2</sup>) of signal-processing equipment areas shall develop and implement a written pre-fire plan. (See also Annex E.)

**10.1.1.1** The pre-fire plan shall be reviewed and updated as personnel changes, management structure realignment, or facility changes occur that potentially affect the existing pre-fire plan.

**10.1.1.2** All employees of the facility shall be provided with appropriate information regarding their emergency assignments, relocation, or evacuation during an emergency.

**10.1.1.3\*** This plan shall identify authority responsibilities and actions of employees.

**10.1.1.4** All documentation shall be in writing and approved by the management of the facility.

**10.1.1.5\*** For telecommunications facilities containing more than 13,935 m<sup>2</sup> (150,000 ft<sup>2</sup>) of signal-processing equipment areas, the plan shall include an annual exercise of the plan.

**10.1.2 Elements.** A pre-fire plan shall be developed and shall include the following:

- (1) Identification of an emergency contact and telephone number
- (2) Life safety issues of the occupants of the facility
- (3) Life safety of the responding fire fighters to the facility
- (4) Life safety issues of the community provided by the telecommunications facility through its normal operation and its continuity during fire emergencies (e.g., 911-type services)

**10.2\* Life Safety of Occupants of the Facility.** As part of the pre-fire plan, a building evacuation procedure shall be developed, exercised, and updated annually.

**10.2.1** All employees shall receive orientation regarding the building evacuation procedure.

**10.2.2** In circumstances regarding specially assigned tasks, orientation shall be provided.

**10.3\* Fire Safety of Fire Fighters.**

**10.3.1 Fire Department Information.** Where requested by the local fire department, the following shall be provided:

- (1) A general description of the telecommunications equipment within the building and how it is powered
- (2) An up-to-date floor plan(s)
- (3) Actions to be taken concerning ventilation and the prevention of contamination of areas not affected by the fire

**10.3.2\* Fire Service Orientation and Information.** When requested by the local fire department, orientation and information shall be provided to the fire personnel by the company management as follows:

- (1) A general description of the facilities and all the telecommunications equipment
- (2) An orientation walk-through of the facility to address all the orientation and information issues to ensure that life safety, fire protection systems, and service continuity are upheld

**10.4\* Selective Depowering**

**10.4.1\*** A procedure shall be developed or a knowledgeable person shall be available for selective depowering of portions of the facility electrical systems. (See Sections 6.5 and 7.5).

**10.4.2** Selective depowering of the electrical systems shall be performed only after the investigation and evaluation indicates either one or both of the following:

- (1) Intervention will mitigate the event.
- (2) Removal of a circuit pack or power to an overloaded circuit will terminate the event.

## Chapter 11 Small Unoccupied Structures

**11.1 Scope.** This chapter shall apply to small structures that are normally unoccupied and that house telecommunications equipment, including on-grade, walk-in cabinets; on-grade huts; cell huts; and controlled environmental vaults (CEVs).

### 11.2 General.

**11.2.1** The provisions of Chapters 4 through 10 shall not be required for facilities covered by this chapter.

**11.2.2** For the application of NFPA 101 and NFPA 5000, the occupancy shall be classified as special-purpose industrial.

**11.2.3\*** Portable fire extinguishers shall not be required in these facilities.

## Annex A Explanatory Material

*Annex A is not a part of the requirements of this NFPA document but is included for informational purposes only. This annex contains explanatory material, numbered to correspond with the applicable text paragraphs.*

**A.1.1** It is not intended that this standard apply to private telecommunications facilities. Private telecommunications facilities include rooms specifically used for a business to deliver telecommunications to its employees, containing telecommunication for employees of a company. However, private telecommunications facilities do not include facilities that are owned by non-utility business that provide telecommunications services to the public, including, but not limited to, large medical facilities, universities, large corporate telecommunications networks, military bases, and private prisons. Telecommunications facilities are referred to as *telephone exchanges* in NFPA 101 and NFPA 5000. The 2012 edition of NFPA 101 classifies telephone exchanges as special-purpose industrial occupancies, and the 2012 edition of NFPA 5000 classifies telephone exchanges as industrial occupancies.

**A.1.2** This standard is intended to avoid requirements that could involve unnecessary complications for or interfere with the normal use, occupancy, and operations of telecommunications facilities and equipment.

This standard provides a means by which the industry's accepted fire safety methods are applied to continue the historically good fire safety record of these facilities.

Fire loss records for the industry are compiled infrequently. The most current authoritative study can be found in the Federal Communications Commission Network Reliability Council Report to the Nation, Section G, "Fire Prevention in Telecommunications Facilities." This report includes a compilation of fire incidents, a root cause of analysis, and recommended countermeasures and business practices. Additional information is found in the NFPA *Fire Protection Handbook*. In general, the lessons learned in the prior incidents have been incorporated into this document.

The telecommunications industry has a remarkably good fire safety record, with the exception of only a few highly visible incidents, which do not diminish its overall performance record.

**A.1.3** This document contains both performance and prescriptive requirements for new buildings and installations. Existing buildings and installations were designed using prescriptive features and are difficult to summarize into one comprehensive set of prescriptive requirements. Existing buildings could benefit from an evaluation using a performance-based perspective.

The performance of the varying prescriptive standards in existing buildings has been validated over time. Care should be taken when this document is applied in existing buildings because the new prescriptive requirements could vary from the existing standard.

**A.1.3.2** The presence of batteries directly supporting power and fuels for standby engines has been considered in the occupancy classification of these facilities.

Telecommunications facilities are unique in their fire resistant/limited combustibility construction and the degree of control and high standards for content ignition and combustibility.

**A.1.5** Users of this standard outside of the United States and Canada should be aware that telecommunications equipment and cables used in the United States and Canada have fire resistance properties that limit flame spread and fire growth.

**A.1.5.2** Telecommunications facilities declared as being replaceable under Chapter 7 should not contain telecommunications equipment hazard areas that are not replaceable.

**A.3.2.1 Approved.** The National Fire Protection Association does not approve, inspect, or certify any installations, procedures, equipment, or materials; nor does it approve or evaluate testing laboratories. In determining the acceptability of installations, procedures, equipment, or materials, the authority having jurisdiction may base acceptance on compliance with NFPA or other appropriate standards. In the absence of such standards, said authority may require evidence of proper installation, procedure, or use. The authority having jurisdiction may also refer to the listings or labeling practices of an organization that is concerned with product evaluations and is thus in a position to determine compliance with appropriate standards for the current production of listed items.

**A.3.2.2 Authority Having Jurisdiction (AHJ).** The phrase "authority having jurisdiction," or its acronym AHJ, is used in NFPA documents in a broad manner, since jurisdictions and approval agencies vary, as do their responsibilities. Where public safety is primary, the authority having jurisdiction may be a federal, state, local, or other regional department or individual such as a fire chief; fire marshal; chief of a fire prevention bureau, labor department, or health department; building official; electrical inspector; or others having statutory authority. For insurance purposes, an insurance inspection department, rating bureau, or other insurance company representative may be the authority having jurisdiction. In many circumstances, the property owner or his or her designated agent assumes the role of the authority having jurisdiction; at government installations, the commanding officer or departmental official may be the authority having jurisdiction.

**A.3.2.3 Listed.** The means for identifying listed equipment may vary for each organization concerned with product evaluation; some organizations do not recognize equipment as listed unless it is also labeled. The authority having jurisdiction should utilize the system employed by the listing organization to identify a listed product.

**N A.3.3.2.4 Sodium-Nickel Battery.** In VRLA batteries the liquid electrolyte in the cells is immobilized in an absorptive glass mat (AGM cells or batteries) or by the addition of a gelling agent (gel cells or gelled batteries).

**N A.3.3.2.5 Valve-Regulated Lead Acid (VRLA).** Vented batteries have a provision for the user to add water to the cell and are equipped with a flame-arresting vent that permits the escape of hydrogen and oxygen gas from the cell in a manner such that a spark or other ignition source outside the cell will not ignite the gases inside the cell.

**A.3.3.20 Voice over Internet Protocol (VoIP).** VoIP communications do not use a defined connection for the duration of the call. It is most probable that segments of the call will be routed over a variety of connections and through a variety of telecommunications facilities. The transmission of voice telecommunications using VoIP can result in a variety of telecommunications facilities (i.e., the Internet cloud) being used for the completion of one call.

**A.3.4.11 Technical Support Area.** These areas are usually separated from the equipment area by glass or solid partitions and have one or two computer workstations where technicians program the signal-processing equipment. These areas are not occupied on a full-time basis.

**A.3.4.12 Telecommunications Equipment Area.** This includes hazard areas such as a signal-processing equipment area, cable entrance facility (CEF) area, power area (including batteries), main distribution frame (MDF) area, standby engine area, and technical support areas contiguous to the above hazard areas and noncontiguous technical support areas.

The tree shown in Figure A.3.4.12 assists in understanding the space/area and equipment hierarchy in telecommunications facilities.

**A.3.5** There are two key reasons for detection in telecommunications facilities as follows:

- (1) Rapid detection of a fire, pre-alarm condition, to allow operations time to intervene prior to fire department deployment and larger scale incidents
- (2) Locate the source of the fire within reason to assist with surgical depowering efforts, particularly important for operations that receive a pre-alarm condition

**A.3.6.2 Cable Entrance Facility (CEF) Equipment.** Large cables from the outside are spliced to smaller cables or wires that run to the main distribution frame or signal-processing equipment.

**A.3.6.4 Main Distribution Frame (MDF) Equipment.** Auxiliary equipment could include central testing equipment used to determine the electrical characteristics of the circuits.

**A.3.6.6 Signal-Processing Equipment.** This equipment typically includes, but is not limited to, switch and transport/access equipment, servers, routers, computers, and cable television equipment that establishes any form of one- or two-way communications. The equipment is generally owned or leased

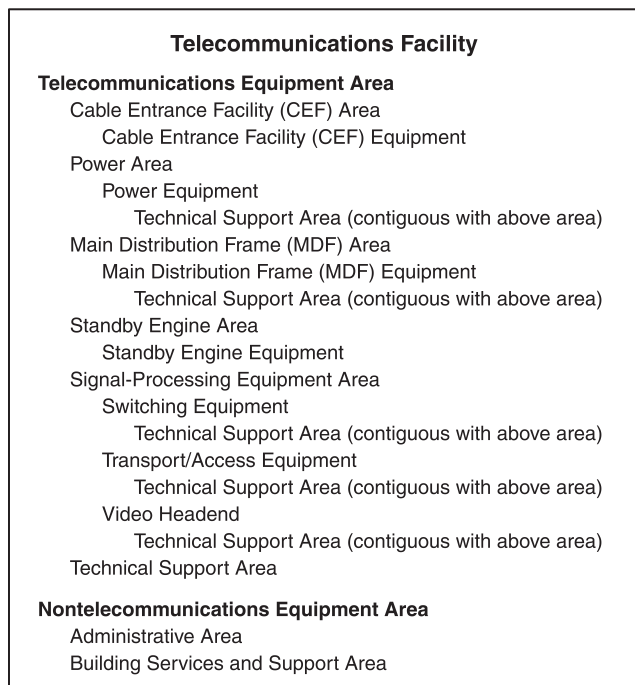

**FIGURE A.3.4.12 Space/Area and Equipment Hierarchy in Telecommunications Facility.**

by a telecommunications company offering wired telephone, wireless, cable television, or internet service.

**A.3.7.2 Exposure Fire.** This term usually refers to a fire that starts outside a building (e.g., wildland fire or vehicle fire) and that consequently exposes the building to a fire. Exposure fires include fires starting in areas or floors occupied by other tenants of a multiple-tenant building.

**A.3.7.3 Fire Model.** Due to the complex nature of the principles involved, fire models are often packaged as computer software. Relevant input data, assumptions, and limitations needed to properly implement the model should be considered. The user should be aware of the limitations of the software or calculation method and not exceed these limitations.

**A.3.7.4 Fire Scenario.** The fire scenario describes factors critical to the outcome of the fire such as ignition sources and locations, nature and configuration of the fuel, ventilation, characteristics and locations of occupants, and condition of the supporting structure and other equipment.

**A.3.7.8 Performance Criteria.** Engineering terms include temperatures, radiant heat flux, and levels of exposure to fire products. Performance criteria provide threshold values that are treated as data for calculations used to develop a proposed design and implementation plan.

**A.3.8.1 Aisle.** The key elements of this definition are as follows:

- (1) Passageway between equipment, meaning it is intended for movement of people and/or equipment
- (2) Typically between opposing rows of telecommunications equipment enclosures or racks but could be between two freestanding pieces of equipment

- (3) Intended for routine human activity such as service or operation (therefore not a plenum space)

**A.3.8.2 Aisle Containment.** The key elements of this definition are as follows:

- (1) An occupied area (excluding areas above a ceiling or below a raised floor)
- (2) Utilizing “nonstructural separation” between hot and cold air (excluding construction methods such as fire-rated walls)
- (3) The aisle can be a “hot aisle,” a “cold aisle,” or a mix of both at select portions of the aisle

**A.3.8.3 Cold Aisle.** The key elements of this definition are as follows:

- (1) Airflow is controlled
- (2) Intake air is cold, implying an aisle normally intended for operation of the telecommunications equipment
- (3) Air is from the output of the HVAC

**A.3.8.4 Hot Air Collar.** The key elements of this definition are as follows:

- (1) Air conveyance assembly, sometimes referred to as a “duct” or a “chimney”
- (2) Typically from specific equipment rather than from larger areas such as aisles
- (3) Not required to be physically connected to a duct or plenum

**A.3.8.5 Hot Aisle.** The key elements of this definition are as follows:

- (1) Airflow is controlled
- (2) Exhaust air is hot, implying an aisle normally intended for servicing of the telecommunications equipment
- (3) Air returns to the input of the HVAC

**A.4.1.2** The hazard of adjacent tenants/occupancies should be identified and evaluated with respect to the consequences that could result from a fire or explosion exposure to the telecommunications equipment areas.

**A.4.2.1** The complexity and scope of signal-processing operations can make it necessary to provide internal redundancy, alternative routing, and in some cases dual access terminal in order to prevent communication outages.

**A.5.1.1** The objectives of this standard are as follows:

- (1) Provide fire protection measures so that the risk of injury or death due to fire in a telecommunications facility is comparable to the levels of risk abatement for similar business-type uses
- (2) Provide fire protection measures so that telecommunications equipment is not damaged due to a fire to a point that the damage will have an unacceptable impact on network operation
- (3) Provide fire protection measures so that property is not damaged due to a fire to a point that the damage will have an unacceptable impact on property

**A.5.1.2** Qualifications should include experience, education, and credentials that demonstrate knowledgeable and responsible use of applicable models and methods.

**A.5.1.3** A third-party reviewer is a person(s) selected to review proposed performance-based designs. SFPE's *Guidelines for Peer Review in the Fire Protection Design Process* provides guidance on the review process for fire protection designs.

**A.5.1.5** Continued compliance with the goals and objectives of this standard involves many things. The building construction — including openings, interior finish, and fire- and smoke-resistant construction; contents and hazards within the facility; and the facility fire protection systems — should retain at least the same level of performance as provided by the original design parameters. The use and hazards should not change to the degree that assumptions made about life safety and network reliability characteristics, combustibility of furnishings, and existence of trained personnel are no longer valid.

In addition, actions provided by other personnel, such as emergency responders, should not be diminished below the documented assumed levels. Also, actions needed to maintain reliability of systems at the anticipated level should meet the initial design criteria. Significant changes in any of these factors should result in a review of the performance plan.

**A.5.3.1** See Figure A.5.3.1.

**A.5.3.2.1** One method that has been demonstrated to provide a measure of the ability of equipment to withstand elevated temperature exposure is ANSI/IEEE 304. Additional information can be found in Telcordia's GR-63-CORE.

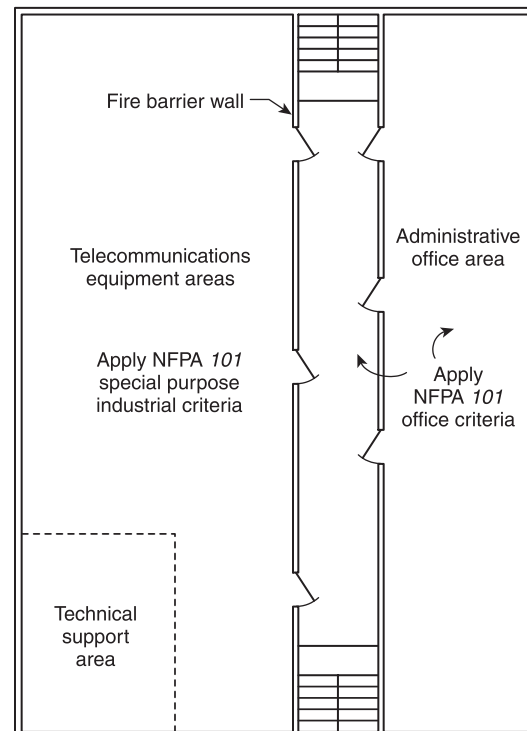

**FIGURE A.5.3.1** Example of the Application of NFPA 101 to Telecommunications Equipment Areas and an Administrative Office Area.

**A.5.3.2.2** Acid corrosion and conductive products of combustion have been known to cause problems after fires. (Also see *Annex D*.) The following paragraph is extracted from “Smoke Corrosivity: Generation, Impact, Detection and Protection Colloquium on Smoke Corrosivity”:

“In general, an electronic switch would be expected to accumulate zinc chloride levels in the range of 30 to 60  $\mu\text{g}/\text{in.}^2$  (micrograms per square inch) from interaction with the normal environment over its expected lifetime of 20+ years. A clean product is expected to have less than 10  $\mu\text{g}/\text{in.}^2$  of chloride contamination present. After exposure to a fire involving halogenated materials, we have observed levels that range from 30 to 6000  $\mu\text{g}/\text{in.}^2$ . As a general rule we have found that telecommunications equipment with contamination levels below 200  $\mu\text{g}/\text{in.}^2$  can be easily restored to service with very little impact on long-term reliability. Telecommunications equipment with exposure from 200 to 600  $\mu\text{g}/\text{in.}^2$ , can also be restored to service as long as no unusual corrosion problems arise and the environment was strictly controlled soon after the fire. However, as the contamination level rises above 600  $\mu\text{g}/\text{in.}^2$ , the effectiveness of cleaning dwindles and the cost of cleaning quickly approaches the replacement cost of the telecommunications equipment.”

**A.5.4.3** This category of assumptions applies both to systems and features required by this document, that reference applicable standards, and to any additional systems or features included in the design at the discretion of the builder. The referenced standards are hereby expected to state maintenance, testing, and other requirements needed to provide positive assurance of an acceptable level of reliability. The referenced standards themselves could be prescriptive or performance based.

**A.5.4.3.3** Systems addressed by this standard include automatic fire suppression systems and fire alarm systems. Performance issues that need to be documented could include response time indexes, discharge densities, and distribution patterns. Calculations should not include an unlimited supply of extinguishing agent if only a limited supply will be provided in the actual structure or building.

**A.5.5** Scenarios define the challenge to which telecommunications equipment, personnel, and buildings can be exposed. Fire scenarios capture and limit value judgments on the type and severity of the fire challenge to which a proposed fire safety system should respond. The fire safety system includes any and all aspects of the proposed design that are intended to mitigate the effects of a fire, such as materials control, smoke management, egress system, automatic detection and suppression, barriers, staff training, and placement of manual extinguishers.

To provide a comprehensive design (i.e., demonstrate how the fire safety system will respond to a variety of fires), more than one scenario needs to be considered. Scenarios are composed of an initial fire location, an ignition source, the first and second fuel items ignited, and the geometry and ventilation features of confining spaces. In telecommunications areas, the early smoke generation rate and initial growth in fire severity could be significant considerations.

It is desirable to run a wide variety of different fire scenarios to evaluate the range of effects on telecommunications equipment, personnel, and buildings. Fire scenarios should not be limited to a single or a couple of “worst credible” fire scenarios.

Scenarios should not always assume that fire safety systems will function as designed. Furthermore, failure modes and reliability of systems should be included in scenario development.

**A.5.5.1.1** The scenario specifications should be as challenging as could realistically occur in the area.

**A.5.5.2.1** Design fires are typically quantified in terms of their potential generation of heat, smoke, and combustion gases that are released into the environment. The generation of these products could be represented as time-based rates (heat release rates or mass production rates). A fire’s heat release is partitioned between the radiative fraction and the convected fraction transported by the plume. Radiation and convection heat transfer modes control the thermal impact of the fire and should be considered. Smoke and combustion gases are the fire’s mass effluent and are generically termed *species*. In any particular fire scenario, species such as particulate smoke, CO, HCl, HBr, HF, and so forth could be important in terms of telecommunications equipment survivability and life safety hazard and should be quantified when indicated.

Heat release rates and species generation rates for specific burning objects can be obtained from the following:

- (1) Full-scale fire tests
- (2) Estimations from correlation
- (3) Generic fire curves (*t*-squared curves)
- (4) Predictions from fire models
- (5) References, including the *SFPE Handbook of Fire Protection Engineering*, *Drysdale’s Introduction to Fire Dynamics*, and the *SFPE Guide to Performance-Based Fire Protection*

Numerous data sources, fire test methods, correlation, and predictive models are available in the fire safety research and engineering literature. Specific data sources and fire test methods that could be appropriate for fire scenario development are identified in the appendices of the individual scenarios.

**A.5.5.2.1.2** An example of such a scenario would have the failure or fire initiated in a component or system where damaging combustion products would be generated and transported to a nearby critical target. Fire could spread to other components located on different racks or cabinets, depending on the fire exposure from the initially ignited component or systems and the ignition properties of the exposed materials.

Factors to be considered in developing design fire curves for component or systems fire scenarios include the following:

- (1) Chemical composition of wiring insulation, circuit boards and substrates, and electrical components
- (2) Species generation rates of overheated, electrically energized components or devices
- (3) Heat release rate and species generation rates of ignited items, and the potential for fire spread to other items based on the exposure fire and the ease of ignition of other items (racks or cabinets)

Significant amounts of combustion (pyrolysis) products could be generated prior to flaming ignition with overheated, electrically energized telecommunications equipment. These products could pose a direct threat to critical network equipment. Therefore, particular attention should be placed on the pre-ignition scenario development.

Fire tests involving energized signal-processing equipment have demonstrated that where ignition is attributable to an electrical fault, such fires are slow to develop but do release

great volumes of corrosive smoke soon after ignition. Products of combustion emitted during such tests included chlorine from combusted plastics, tin and lead from solder connections, zinc from transistor chip coatings, copper and bromine from circuit boards, manganese, silicon, and so forth. When combined with moisture, chlorine formed hydrochloric acid, and ionic chlorides formed electrically conducting compounds that can lead to corrosion damage and electrical shorts or signal noise in the system. [“Fire Extinguishment Testing of Sprinkler Protected Telecommunications Equipment”; “The Special Need for a Smoke Exhaust System to Minimize Secondary Damage to Electronic Telephone Switching Equipment.”]

Research sponsored by the Nuclear Regulatory Commission and performed by Sandia National Laboratories of the effects of smoke on electronic circuit reliability was performed. The research suggests that particle deposition onto circuit packs leads to bridging and resultant current leakage that contributes to the deterioration of telecommunications equipment performance and a loss of reliability. [Tanaka, Nowlen, and Anderson; Tanaka]

Two useful benchmarks in considering signal-processing equipment fires are a fully involved printed circuit board fire, which can release 5 kW, and a fully involved frame, which can release 150 kW, heat release rate. This higher heat release rate was observed in testing to Telcordia GR-63-CORE.

**A.5.5.2.1.3** The ignition is electrical in nature and caused by an electrical overload or short circuit fault. An example of such a scenario would be arcing ignition of cable insulation resulting in a growing fire and an inability to interrupt power due to failure or absence of emergency power disconnection. Factors to be considered in developing design fire curves for cable fire scenarios include the following:

- (1) Rating of cables (plenum, riser, vertical tray, FMRC Group 1, 2, or 3 of FM Approvals Class Number 3972, *Test Standard for Cable Fire Propagation*, or other appropriate tests)
- (2) Quantity of cables
- (3) Orientation of cables (vertical or horizontal)
- (4) Quantity and composition of materials used in cable construction (jacketing and insulation)
- (5) Presence or absence of fire-stopping materials

Literature values for heat release and species generation rates for cable fires measured in large-scale calorimeter tests can be useful as a basis for scenario and design fire development.

**A.5.5.2.1.4** An example of such a scenario would be ignition of construction waste by a defective or damaged electrical extension cord igniting equipment packaging in a signal-processing equipment area or rack space. Another example would be ignition of computer equipment in an office module and failure to achieve closure of openings connecting to telecommunications equipment areas. Literature values for heat release and species generation rates for typical nontelecommunications equipment fuel packages measured in large-scale calorimeter tests can be useful as a basis for scenario and design fire development. Typical fuels and sources of data can be found in the *SFPE Handbook of Fire Protection Engineering* and in reports of full-scale tests by the Building Fire and Research Laboratories at the National Institute of Standards and Technology.

In the absence of available literature data, large-scale calorimeter tests can be conducted. In some cases, typical nontelecommunications equipment fuel package fire scenarios could be represented by “standard” *t*-squared fires commonly referred to as “slow, medium, fast, and ultra-fast” fires (*see NFPA 72 and SFPE Handbook of Fire Protection Engineering*). Design fire curves should include the heat release contributions of the first fuel ignited and the subsequent fuel packages associated with the scenario in question.

**A.5.5.2.1.5** An example of such a scenario would be failure of a fuel line on an operating generator; vaporization of the spilled fuel on a hot surface with subsequent ignition resulting in a flash fire or deflagration. Another example of such a scenario would be an accidental spill and ignition of a flammable liquid solvent in telecommunications equipment areas and nontelecommunications equipment areas.

Factors to be considered in developing design fire curves for ignitable liquid fires include the following:

- (1) Volatility and flash point of liquid
- (2) Initial quantity spilled and rate of additional liquid release
- (3) Liquid surface area and burning rate

In some cases, the growth phase of ignitable liquid fire scenarios could be represented by “standard” *t*-squared fires commonly referred to as “fast or ultra-fast” fires (*see NFPA 72 and SFPE Handbook of Fire Protection Engineering*).

Some flammable liquids with high vapor pressures can result in explosive range mixtures and damaging deflagrations. Flash fires or deflagrations can also result from accidental releases of liquids into heated environments or onto surfaces above their flash points. Overpressures from explosions and deflagrations can cause further release of fuel or failure of compartment boundaries. Guidance for determining pressure rise is provided in NFPA 68.

**A.5.5.2.1.6** An example of such a scenario would be a combustible gas leaking into a cable entrance facility or vault from sources outside the telecommunications facility followed by ignition of an explosive mixture. Another example of such a scenario would be accumulation of hydrogen gas produced from battery use in an area with inadequate ventilation followed by ignition of an explosive mixture. Guidance for determining pressure rise can be found in NFPA 68.

**A.5.5.2.1.7** An example of such a scenario would be a fire in a nontelecommunications third-party controlled space involving flaming ignition of stored upholstered furniture that is controlled but not extinguished by a sprinkler system. The fire compartment is open to a corridor that is common to a leased area containing telecommunications equipment such as signal-processing equipment.

Factors to consider in analysis of interior exposure fire scenarios include the following:

- (1) The nature and degree of closure of the opening between compartments
- (2) Integrity of fire and smoke barriers between compartments
- (3) The presence or absence of telecommunications equipment in the exposed area

Experimental values of heat release rate and species generation rates for suppressed and unsuppressed full-scale compart-



ment fires are available in the literature and can be a basis for the interior exposure fire.

**A.5.5.2.1.8** An example of such a scenario would be a fire involving chemicals producing corrosive products of combustion and a failure of the detection system to shut down air intakes for the HVAC serving a central office facility.

Factors to consider in analysis of exterior exposure fire scenarios include the following:

- (1) Existing and potential property uses of the adjacent property
- (2) Property line setback (separation distance)
- (3) Exposure geometry (shape factor)
- (4) Radiant flux required for ignition
- (5) Ignition and flame spread properties of exposed materials
- (6) Degree of closure or protection of outside air intake
- (7) Proximity of driveways or loading docks to fresh air intake

**A.5.6.6** The performance predicted by the performance design analysis should be verified by field testing of the installed systems and subsystems. Where a fire detection system is used in a performance-based approach, system performance should be verified by test. VEWFD systems should be designed, installed, and maintained to detect the products of combustion from the heated wire test described in Annex B. EWFD systems should be designed, installed, and maintained to detect the products of combustion from the lactose–potassium chlorate test described in Annex B.

It should be recognized that there are potential fire scenarios in most telecommunications facilities that can grow to the point where a major service interruption can occur before an effective response can be mounted by facility personnel. Examples of such scenarios include fires of incendiary origin and arcing short circuits in battery plants or other primary power systems or cables. Because fires involving these scenarios are rare, the performance objectives and design approaches in this document have been developed to provide protection against more frequently occurring scenarios.

The performance verification indicated in 5.6.6 is based in part on the criteria in BS 6266. The criteria define test fires for the VEWFD and EWFD levels of fire detection discussed in this document. The appropriate test fire is used to properly demonstrate fire detection system operation at initial acceptance and subsequent periodic system testing.

Fire detection systems should be designed, installed, and maintained to detect the test fires referenced in this section when the HVAC system serving the area is operating at normal air exchange rates, and also when the HVAC system is shut off. They should also be designed, installed, and maintained to detect the test fires when telecommunications equipment in the area is fully operational.

It is common practice in some companies for some areas to have minimal HVAC for energy conservation purposes. This is typical in colder regions where mechanical cooling is not necessary to relieve the heat gain from telecommunications equipment with high energy density. Fan cycling is also a typical condition for telecommunications equipment with lower energy density that does not produce as much heat (e.g., frame areas, many transmission systems). Because a fire of a given size can cause the same damage irrespective of airflow in the area, it is essential that the fire detection system be able to function

in any foreseeable condition. This recommendation can also ensure adequate fire detection in the event of fan failure.

**Δ A.6.1.1** The fire protection required is based on noncombustible construction, fire ratings of major systems installed in the telecommunications areas, compartmentation of fire areas, EWFD and VEWFD systems, and effective response of trained individuals.

Traditional telecommunications industry practices for fire safety have been largely based on a chain of necessary actions and elements. Any missing action or element breaks the chain and increases the fire risk. The successful chain might include the following:

- (1) Fire prevention practices, when needed
- (2) Noncombustible construction
- (3) Compartmentation
- (4) Fire-resistance-rated equipment
- (5) Fire-resistance-rated cable
- (6) Very early warning fire detection
- (7) Alarm processing and notification
- (8) Response by knowledgeable personnel
- (9) Power interruption
- (10) Fire suppression, when needed
- (11) Smoke ventilation, when needed

The prescriptive solutions found in this standard are based on maintaining this chain unbroken for the life of a telecommunications facility.

Those prescriptive solutions are based on the widespread use of fire-resistance-rated telecommunications equipment and cables. Successful fire protection of major portions of the U.S. telecommunications network includes a strong reliance on very slowly developing fires in fire-resistive equipment and cables, appropriate response, and manual intervention. Implementation of that strategy and sequence has enabled large portions of the industry to compile its remarkable fire record.

For areas in which the predominant equipment and cable is not fire resistance rated, the chain is broken. An alternative strategy is required, generally including automatic suppression systems. Indeed, segments of the industry rely upon automatic suppression systems as part of its network fire protection practices.

**A.6.1.2** The prescriptive approach consists of elements including fire-resistant major telecommunications equipment systems, cable, and wire; compartmentation; fire detection; alarm processing; and manual intervention strategies as the primary means to prevent major network failure due to fire.

**A.6.1.3** See Figure A.6.1.3(a) and Figure A.6.1.3(b).

**A.6.1.4** The objective in multiple-tenant buildings not controlled by the telecommunications service providers is to ensure that the telecommunications facility is located in a building that has a low probability of a catastrophic fire loss. As such, care should be taken in selecting the host structure to house the telecommunications facility, both from a fire protection and risk consideration (see Chapter 4).

**A.6.3** Site selection should anticipate exposures from other hazards such as flood and earthquake.

**A.6.4** Standard 29 CFR 1910.268(b)(1)iii specifies that wiring and maintenance aisles are working spaces and are not part of the means of egress for purposes of 29 CFR 1910.34.

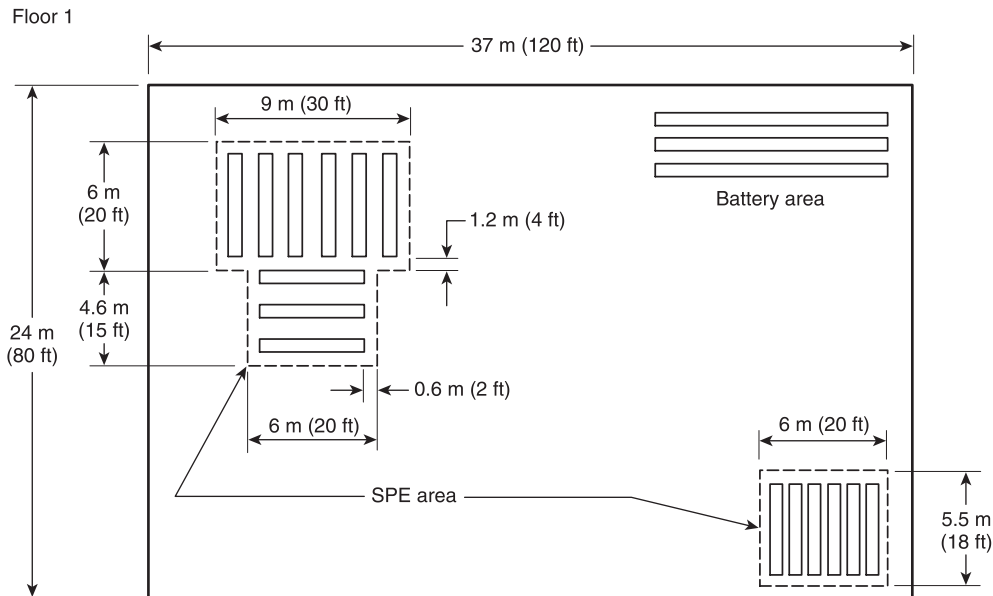

Calculated signal-processing equipment (SPE) area is  $117 \text{ m}^2$  ( $1260 \text{ ft}^2$ ).  
 The calculations do not consider the room size.  
 The battery area is not an SPE area.  
 The  $232 \text{ m}^2$  ( $2500 \text{ ft}^2$ ) threshold is not exceeded if a single story facility.

**FIGURE A.6.1.3(a) Example 1 of Calculated Signal-Processing Equipment Area.**

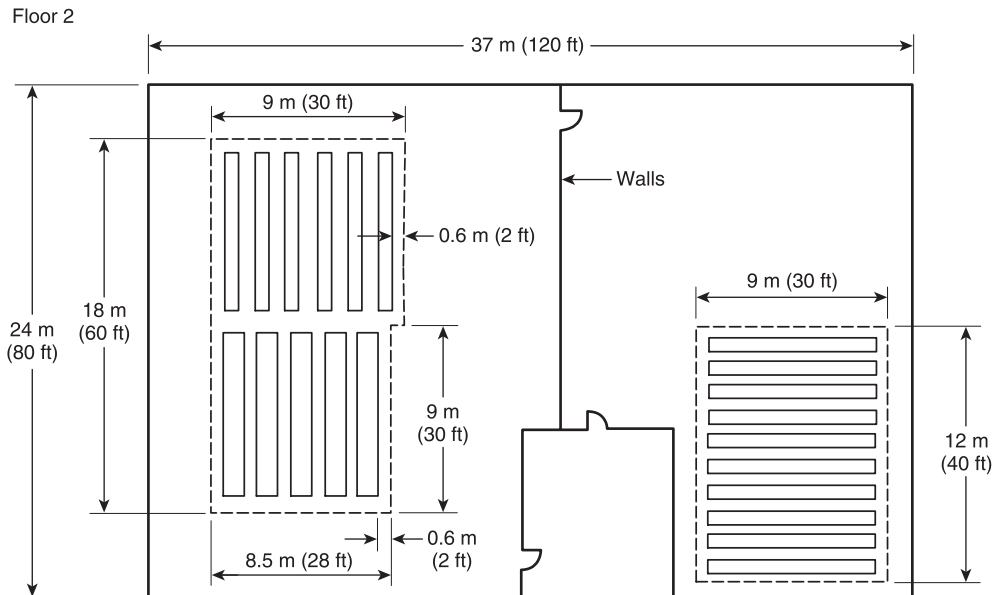

Calculated signal-processing equipment (SPE) area is  $273 \text{ m}^2$  ( $2940 \text{ ft}^2$ ).  
 The calculations do not consider the room size.  
 Floor 1 and Floor 2 SPE areas in the same building should be added together to determine the accumulated SPE area in a multistory telecommunications facility.

**FIGURE A.6.1.3(b) Example 2 of Calculated Signal-Processing Equipment Area.**

**A.6.5** The intent is to provide a procedure and any necessary marking of disconnect equipment to remove all sources of power from specific equipment or building areas that could be electrically overloaded or involved in a fire incident. The intent is not to provide an emergency power off capability as required in Article 645 of *NFPA 70* and *NFPA 75*, because the use of telecommunications equipment and the consequences of disconnecting power are more severe than for the IT equipment covered by the requirements of *NFPA 70* and *NFPA 75*. The means to disconnect power should not be readily available to a casual occupant of the facility. It is permitted to require special knowledge of the power systems to operate the disconnecting means.

**A.6.5.1** The depowering procedure often includes special marking of otherwise standard power disconnect equipment. The depowering procedure is permitted to be progressive, depending upon the severity of the incident, from circuit pack to equipment bay to area of a central office (see *Figure A.6.5.1*).

**A.6.5.2** Figure A.6.5.2(a) and Figure A.6.5.2(b) show typical telecommunications facility power sources indicating selective disconnect points and dc power distribution.

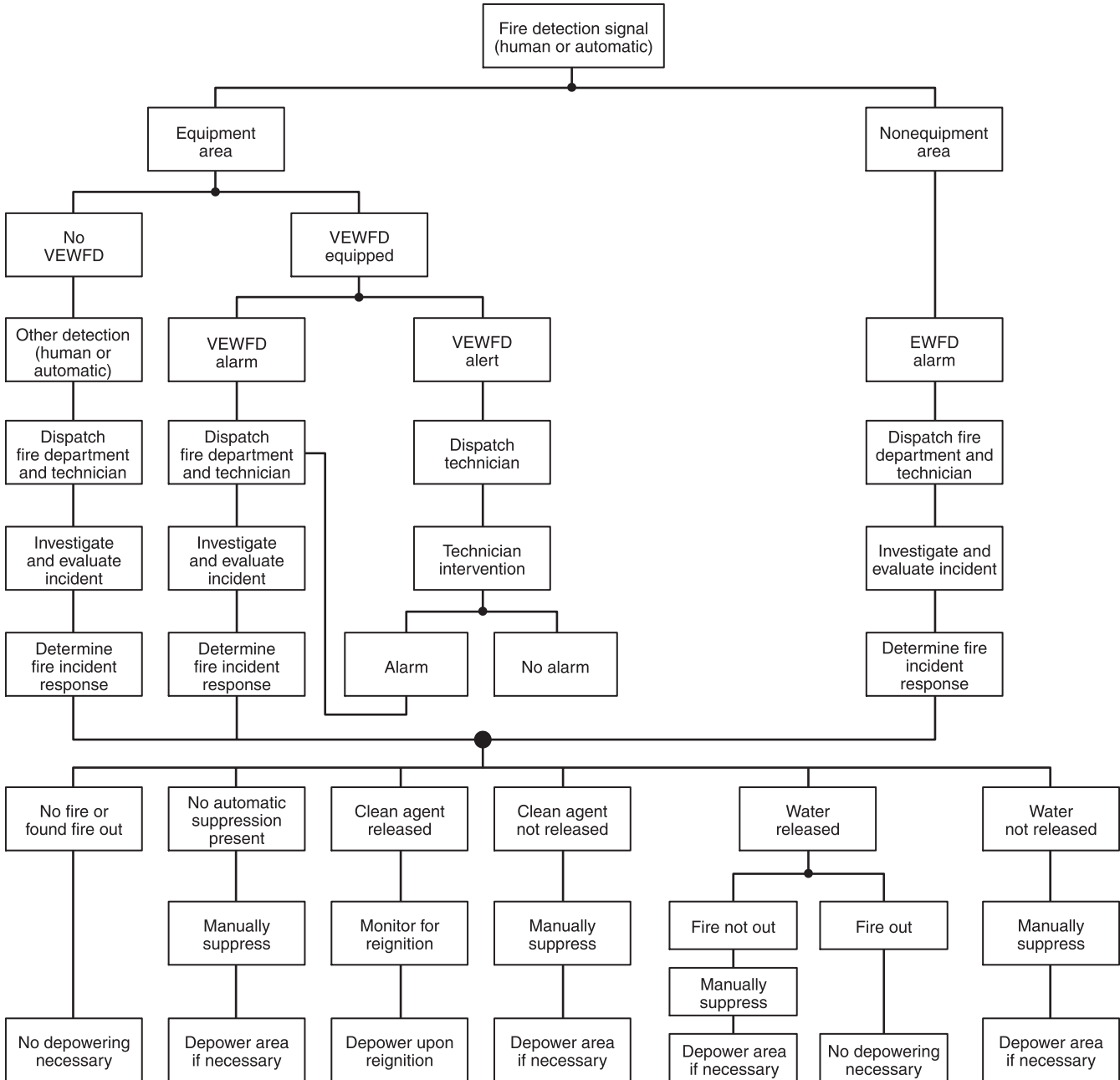

**FIGURE A.6.5.1** Depowering Decision Tree.

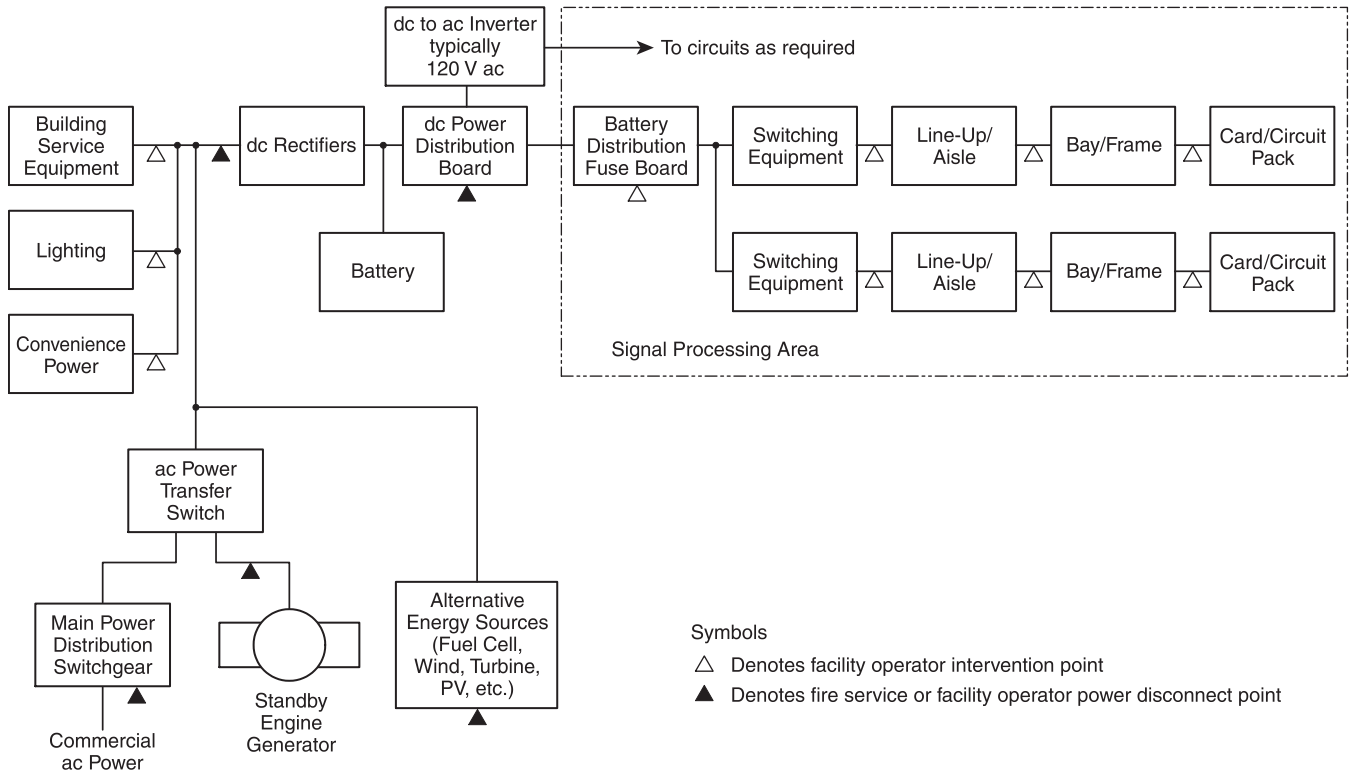

FIGURE A.6.5.2(a) Typical Telecommunications Facility Power Sources Indicating Selective Disconnect Points.

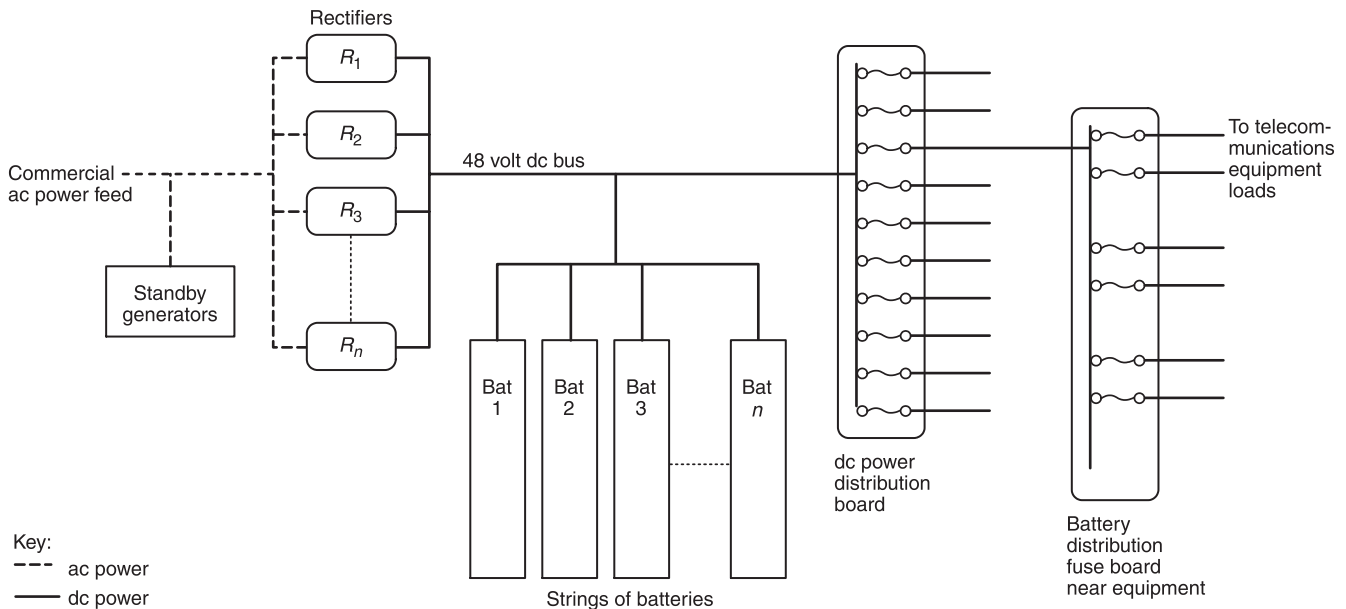

FIGURE A.6.5.2(b) Typical Telecommunications Facility dc Power Distribution.

**N A.6.6.1** An HVAC economizer is a dampered vent system designed to lower energy costs by taking in outside air to cool the telecommunications facility. This use has the risk of introducing smoke from outside the facility.

Where HVAC units operate in economizer mode using outside air intakes serving signal-processing equipment areas, smoke detection should be provided unless filters with minimum efficiency reporting value (MERV) ratings of 13 or greater are used to filter the outside intake air. For more information on MERV ratings, see ASHRAE 52.2.

The practice of detecting smoke from a source outside the facility will help facility personnel be aware that the smoke alarm was not created from an internal building thermal event, but from smoke outside the facility, and will notify them as to where to investigate the thermal event. This investigation will begin outside the facility, not inside the facility.

Where economizers introduce outside air, outside air intakes serving the space should be provided with VEWFDF prior to filtration, and detection sensitivity should meet or exceed the detection sensitivity in the signal-processing area.

Each outside air intake should be monitored by detectors or ports prior to filtration to monitor incoming air for smoke. An appropriate number of spot-type smoke detectors or ports should be installed to efficiently and adequately cover designated outside air intakes. Detector or port spacing for outside air intake detection should be based upon a distribution of a maximum of one (1) detector or port for every 0.37 m<sup>2</sup> (4 ft<sup>2</sup>) of intake opening. Spot-type smoke detectors or ports should not be directly exposed to the outside environment. Precautions should be taken to ensure that detectors or air sampling smoke detection apparatuses operate within their listed temperature range and condensation is prevented from entering the detector or air sampling spot-type smoke detector apparatus. Spot-type smoke detectors or ports should be installed in accordance with the manufacturer's published instructions. Spot-type smoke detectors or ports monitoring outside air intakes are supervisory conditions to the fire alarm control unit (FACU) only and should not alarm the building, causing evacuation.

**A.6.6.5.2** The confirmation of the presence of smoke can be accomplished by the following:

- (1) Cross-zoning
- (2) Time/smoke density factors
- (3) Activation of multiple detectors
- (4) Manual pull station in combination with detection strategy
- (5) Heat detection
- (6) Automatic suppression system actuation

**A.6.6.7** The objective is to prevent undesirable smoke movement between compartments or areas or both while permitting HVAC operation to prevent telecommunications equipment from overheating.

**A.6.6.8** HVAC operation within a fire-affected compartment is permitted until it circulates smoke that contributes to the signal-processing equipment contamination.

**A.6.7.1** The telecommunications facility normally has a battery system to operate the telecommunications equipment during power failure. This enables the public to use the communication network during power failures or planned outages for

equipment servicing. In selected cases, where the telecommunications company acknowledges adequate power reserve, the battery system can be used as a source for emergency lighting systems as required by NFPA 101.

**A.6.7.2** The telecommunications facility battery system is normally designed for a 3-hour battery reserve when the facility has an auto start backup generator. Longer battery reserves can be supplied when the facility is served by a portable or manual start backup generator.

**A.6.8.1** Signal-processing equipment areas should be arranged to provide protection against fires in adjacent areas; to provide protection against fire spread to adjacent equipment; and to provide protection from fire, smoke, and related thermal and nonthermal equipment damage.

Large cables enter a telecommunications facility in underground ducts. These ducts can collect combustible gases and liquids and direct them toward the telecommunications facility. The cable penetrations should be sealed to prevent gas and liquid intrusion into the building.

**A.6.8.2.2.3** Floor pullers should be located in break-open boxes.

**A.6.8.3** Compliance with compartmentation should be achieved in existing signal-processing equipment areas, provided rated separations and listed penetrations are practicable.

**A.6.8.4.2** Central building services equipment (e.g., chillers, pumps, main air handlers, boilers) should not be located in signal-processing equipment areas. Self-contained air-conditioning units should be located outside of the signal-processing equipment areas unless there is a need to place them within the signal-processing equipment areas. It is preferable to install HVAC ducts serving non-signal-processing equipment areas so that they do not pass through signal-processing equipment areas.

**A.6.8.5.1** The signal-processing equipment area is designated according to the classification level of the signal-processing equipment within the area, thus determining the level of risk of fire ignition and fire spread for the area.

**A.6.8.5.2** A provision of wires, cables, and signal-processing equipment that is resistant to ignition and subsequent fire spread has a direct reduction on the frequency and severity of fires in telecommunications facilities.

**A.6.9.1** Cable entrance facilities should be arranged to minimize the intrusion of gas into the building, to limit the fuel load, to prevent the spread of fire and smoke to other areas, and to prevent the intrusion of unwanted electrical sheath currents.

**A.6.9.3.2** Central building services equipment (e.g., chillers, pumps, main air handlers, boilers) should not be located in the cable entrance facility area. Self-contained air-conditioning or heating units located inside the cable entrance facility area should not service other areas. It is preferable to install HVAC ducts serving other areas so that they do not pass through the cable entrance facility area.

**A.6.9.4** Cable entering the cable entrance facility from outside normally does not have any fire-resistive properties, because it is buried and not exposed to fire. This incoming cable is then spliced to cable, which complies with 8.8.2, in order to connect to equipment elsewhere in the facility.

**A.6.9.4.2** A provision of wire, cable, and equipment that are resistant to ignition and subsequent fire spread has a direct reduction on the frequency and severity of fires in telecommunications facilities.

**A.6.9.5.2** A provision of signal-processing equipment that is resistant to ignition and subsequent fire spread has a direct reduction on the frequency and severity of fires in telecommunications facilities.

**A.6.10.1** Power areas should be arranged to enhance the survivability of power equipment for continuity of service and be arranged to provide protection against fire and smoke spread to adjacent areas, to provide protection against fire and smoke spread to adjacent telecommunications equipment, and to provide for the capability to disconnect power from signal-processing telecommunications equipment to facilitate emergency intervention.

**A.6.10.3.2** Central building services equipment (e.g., chillers, pumps, main air handlers, boilers) should not be located in power areas. Self-contained air-conditioning units should be located outside of the power areas unless there is a need to place them within the power areas. It is preferable to install HVAC ducts serving other areas so that they do not pass through the power areas.

**A.6.10.4.2** A provision of wire, cable, and equipment that is resistant to ignition and subsequent fire spread has a direct reduction on the frequency and severity of fires in telecommunications facilities.

•  
**N A.6.10.8.2.4.2** Methods of achieving this protection can include, but are not limited to, the following:

- (1) Liquidtight sloped or recessed floors in indoor locations or similar areas in outdoor locations
- (2) Liquidtight floors in indoor locations or similar areas in outdoor locations provided with liquidtight raised or recessed sills or dikes
- (3) Sumps and collection systems
- (4) Spill containment systems such as that described in A.6.10.8.2.5.1

[1:A.52.2.2.4.2]

**N A.6.10.8.2.5.1** One method to determine compliance with the neutralization requirements of this subsection is found in Underwriters Laboratories Subject 2436, *Outline of Investigation for Spill Containment for Stationary Lead Acid Battery Systems*. Subject 2436 investigates the liquid tightness, level of electrolyte absorption, pH neutralization capability, and flame spread resistance of spill containment systems. [1:A.52.2.2.5.1]

**N A.6.10.8.2.6** Information on battery room ventilation can be found in IEEE 1635/ASHRAE 21, *Guide to Battery Room Ventilation and Thermal Management*. [1:A.52.2.2.6]

**N A.6.10.8.3.3** A stationary battery array is an arrangement of individual stationary storage batteries in close proximity to each other, mounted on storage racks or in modules, battery cabinets, or other enclosures. [1:A.52.3.2.3]

**N A.6.10.8.3.5.1** A prepackaged stationary storage battery system is designed and investigated as a single unit, assembled in a factory, and shipped to the site. A pre-engineered stationary storage battery system is designed and investigated as a single unit, but is shipped in modular form for assembly at the site. [1:A.52.3.2.5.1]

**N A.6.10.8.3.6.4** This section is intended to address unique situations where the installation of different types of batteries in the same room or cabinet could create a situation where there is unacceptable chemical, thermal, or other interaction between them, or where the surrounding environment is not within the battery manufacturers' specifications. The AHJ has the option to require a hazard mitigation analysis, conducted in accordance with 6.10.8.3.4, to identify hazards and potential solutions that will mitigate the hazards. [1:A.52.3.2.6.8]

**A.6.10.9** Where spill containment systems are used, they should be evaluated to address flammability. The assessment should take into consideration the ignition resistance and propensity to propagate fire of the product assembly with consideration of the contribution of the components (outer encasement, absorbent materials, liners, or other components).

A previous loss investigation determined that the fire originated in the battery rack and that the flame spread was promoted by the flammability of the fabric covering on the acid spill containment bags.

ASTM E648 can be used to determine the critical flux for propagation of flames along spill containment systems when installed on a floor. The most stringent requirement of model building or fire codes is Class 1, which has critical flux of 0.45 W/cm<sup>2</sup>.

**A.6.10.9.1** For the installation of stationary fuel cell power systems, see NFPA 853. For solar photovoltaic (PV) systems, see Article 690 of *NFPA 70*. For fuel cell systems, see Article 692 of *NFPA 70*. For small wind electric systems, see Article 694 of *NFPA 70*.

**Δ A.6.11.1** Main distribution frame (MDF) areas should be arranged to provide protection against fires in adjacent areas, to protect against fire spread to adjacent telecommunications equipment, to provide protection from smoke and related nonthermal damage, and to enhance the survivability of the main distribution frame equipment and adjacent signal-processing equipment. The restoration time for an urban MDF that has incurred significant fire or water damage can be measured in weeks, with a resultant loss of telecommunications service for tens of thousands of subscribers until the MDF is restored or replaced.

**A.6.11.2.2.3** Floor pullers should be located in break-open boxes.

**A.6.11.3** Compliance with compartmentation should be achieved in existing main frame distribution areas, provided rated separations and listed penetrations can be achieved.

**A.6.11.4.2** Central building services equipment (e.g., chillers, pumps, main air handlers, boilers) should not be located in main distribution frame areas. Self-contained air-conditioning units should be located outside of the main distribution frame areas unless there is a need to place them within the main distribution frame areas. It is preferable to install HVAC ducts serving others areas so that they do not pass through the main distribution frame areas.

**A.6.11.5.1** The main distribution frame (MDF) consists of numerous structural frames supporting wires, cables, and MDF equipment connected together to create a large assembly. The area with the assembled MDF should be classified as Level A or

Level C in accordance with 8.8.3 in order to determine the fire protection requirements.

**A.6.11.5.2** A provision of wires, cable, and equipment that is resistant to ignition and subsequent fire spread has a direct reduction on the frequency and severity of fires in telecommunications facilities.

**A.6.12.3.1** Standby engine areas for multiple-tenant buildings should comply with the requirements of Section 6.12. Fuel handling for the standby engines should be in accordance with NFPA 30, except that the volume requirements for tank location and fuel protection should apply to the total aggregated volume in the tank storage area.

**A.6.12.4** Appropriate segregation of the fuel supply is accomplished with a thermally actuated valve or equivalent in the fuel line to the standby generator to isolate the fuel sources from the engine in the event of fire. Drainage or secondary containment systems or both should be provided to prevent fuel spills or leaks from contaminating soils or public drainage systems.

**A.6.12.5** Central building services equipment (i.e., chillers, pumps, main air handlers, boilers) should not be located in standby engine equipment areas. Self-contained air-conditioning units should be located outside of the standby engine equipment areas unless there is a need to place them within the telecommunications equipment areas.

**A.7.1** See A.6.1.1.

**A.7.3** Exposure protection should be provided in accordance with NFPA 80A.

**A.7.6.2** If separate rooms are desired, the signal-processing equipment area should be separated with noncombustible construction.

**A.7.6.3.2** The provisions of wire, cable, and equipment that is resistant to ignition and subsequent fire spread has a direct reduction on the frequency and severity of fires in telecommunications facilities.

**A.7.7.2** Central building services equipment (e.g., chillers, pumps, main air handlers, boilers) should not be located in telecommunications equipment areas. Self-contained air-conditioning units should be located outside of the telecommunications equipment areas unless there is a need to place them within the telecommunications equipment areas.

**A.7.8.1** The telecommunications facility normally has a battery system to operate the telecommunications equipment during power failure. This enables the public to use the communication network during power failures or planned outages for equipment servicing. In selected cases, where the telecommunications company acknowledges adequate power reserve, the battery system can be used as a source for emergency lighting systems as required by NFPA 101.

**A.7.8.2** The telecommunications facility battery system is normally designed for a 3-hour or more battery reserve when the facility has an auto start backup generator. Longer battery reserves can be supplied when the facility is served by a portable or manual start backup generator.

**N A.8.2.3** If an existing telecommunications facility has aisle containment systems added after construction of the room, the principles of 8.2.3 should be followed and the fire protection systems should be modified accordingly.

**A.8.2.3.1** Some aisle containment systems are provided as part of a factory-packaged and listed system by the manufacturer of the telecommunications equipment, while others are field-installed aftermarket systems. In either case, the application of these systems should be in accordance with the manufacturer's instructions.

**A.8.2.3.4** Where plenums are present, the space above the raised floor and below the suspended ceiling is typically accessible space to both occupants and first responders for maintenance access, fire-fighting activities, and so forth, and therefore does not need to be classified as a plenum. The addition of aisle containment systems does not change the hazards contained within those containment areas and therefore does not necessitate different construction materials as required in plenum spaces as defined elsewhere in this standard and others.

**A.8.2.3.6** The temperatures in hot aisles can exceed 37.8°C (100°F), which is often the listing limit on many types of detectors.

**Δ A.8.2.3.7** The design and installation of fire detection and suppression systems for areas in which aisle containment systems are installed should meet the performance or prescriptive requirements of Chapters 5, 6, or 7 that have been applied to the areas.

The following outline provides smoke detector sensitivity and spacing guidance for protection of signal-processing equipment in high airflow areas:

*General.* For smoke detection systems to detect products of combustion, the products must travel from the source to a smoke detector or port and arrive there in sufficient density to be detectable.

Products of combustion follow forced air streams early in the development of a fire or overheat condition where the influence of mechanical systems is greater than the buoyant forces of the fire or overheat condition. Detection system smoke detectors or ports installed in the paths of cooling air exhaust from the cooled equipment can be expected to respond to a small fire in the equipment sooner than smoke detectors or ports located outside of the ventilation air envelope. To be effective, the detection equipment installed within the ventilation air envelope should be suitable to meet the required sensitivity objectives and for the temperatures, air velocities, and other conditions present. If suitable detection equipment cannot be installed within the exhaust ventilation air envelope, a fire in the cooled equipment should be expected to grow to a size at which its energy is sufficient to overcome the mechanical forces of the HVAC containment system.

In the presence of aisle containment systems used to enhance the effectiveness of cooling signal-processing equipment, smoke detectors or ports located in hot aisles or in the above ceiling plenum are required.

Regardless, smoke detectors or ports located on the ceiling in signal-processing equipment areas are a basic requirement and contribute to effective detection over a broad range of signal-processing equipment area configurations.

Listed signal-processing equipment has inherent fire-resistant characteristics. Failing or overheated components or connections can lead to smoldering events that produce smoke

but tend to remain small. In exceptional cases, flaming fires can result.

Automatic fire and smoke detection systems installed to detect smoldering events and/or flaming fires in signal-processing equipment areas are more effective in detecting flaming fires than smoldering events due to the respective release rates of combustion products and the effects of forced air flow on the products of combustion. The greater the air flow, which dilutes and channels detectable products of combustion, the less effective will be the performance of the detection system. Damage or losses that could result from smoldering events or flaming fires in signal-processing equipment prior to detection are likely to be greater in the presence of greater forced air flow due to the likely decrease in detection system performance.

**Smoke Detection Systems for Early Detection.** Where a smoke detection system is installed for the primary purpose of summoning responsible people to the presence of a small signal-processing equipment fire or electrical event that produces smoke (known as “pre-alarm”), the system should be arranged with high sensitivity and close spacing to achieve response to low-density products of combustion suspended in air with reasonable stability and tolerance of the environment.

**Smoke Detection Systems to Initiate Operation of HVAC Dampers or to Close Openings in Fire Rated Walls.** Where a smoke detection system is installed for the primary purpose of initiating operation of dampers, shutters, doors, or other closures in the event of a fire in a signal-processing equipment area, the system should be arranged with medium sensitivity and spacing less than listed spacing to assure the integrity of fire-resistive barriers.

**Smoke Detection Systems to Initiate Release of a Fire Suppression Agent.** Where a smoke detection system is installed for the primary purpose of initiating the release of a fire suppression agent into a signal-processing equipment area, the system should be arranged with low sensitivity, spacing less than listed spacing, and should include a form of logical confirmation of the presence of products of combustion to assure that a single indication does not release the agent.

**Sensitivity and Spacing Ranges.** The following is guidance for sensitivity and spacing ranges for different locations in high airflow areas:

- (1) Where air changes per hour (ACH) in the room served by the ventilation system exceeds 60, and where the supply air is delivered to the room through a raised floor, studies show that smoke detectors or ports under the floor might not be effective in detecting a fire originating under the floor without significantly reducing spacing. Experience has shown that smoke detectors or ports under the floor can be effective in detecting a fire originating in an air-handling unit supplying air to the under-floor space, even in high airflow areas.
- (2) In applying the smoke detector or port spacing, it is recommended that smoke detectors and ports be located at strategic points where smoke is likely to pass; for example, in hot air return streams and at return air registers.
- (3) For smoke detectors and ports installed in the exhaust/return air stream in hot aisles or above ceiling plenums, the spacing and sensitivities listed in Table A.8.2.3.7 should be used. The guidance in Table A.8.2.3.7 comes partly from a study sponsored by the Fire Protection

Research Foundation. That guidance is conservative because it is based on testing using airflow without recirculation into the volume being studied.

Where aisle containment systems are installed in an area after the fire detection or suppression systems have been designed and installed in the area, the design and installation of the fire detection and suppression systems should be reviewed for the following:

- (1) If system changes are necessary to maintain the level of protection as required in 1.4.1.1.
- (2) If changes to the fire detection or suppression systems are necessary to maintain the previously existing level of protection.

Where smoke detectors or ports are installed to monitor return air in accordance with 8.5.3.1.2.3, a review should be conducted to determine that a containment system does not degrade the performance level of the detection system.

**A.8.2.3.8.1** Paragraph 8.2.3.8.1 addresses removable curtains and aisle containment materials, which are otherwise referred to as “removable obstructions.” Fixed obstructions are clearly addressed for suppression systems in NFPA 13. Means other than automatic smoke detection used for removing the obstructions (e.g., thermal, mechanical, and fusible links) still need further research by the industry and are not clearly demonstrating the capability of activating without impacting the timed response of suppression systems.

**A.8.2.3.8.1(1)** This action can be compared to readying the space before suppression, such as initiating the closing of fire doors, dampers, and the like.

**A.8.2.3.8.1(4)** The releasing devices can be similar to those used for initiating fire doors, dampers, and the like.

**A.8.2.3.9** Aisle containment and hot air collars should be reviewed for any impact on the suppression systems, where present, to produce the required design concentration throughout the entire volume they serve.

**A.8.2.3.10.1** Paragraph 8.2.3.10.1 addresses removable curtains and aisle containment materials, which are otherwise referred to as “removable obstructions.” Fixed obstructions are clearly addressed for suppression systems in NFPA 2001. Means other than automatic smoke detection used for removing the obstructions (e.g., thermal, mechanical, and fusible links) still need further research by the industry and are not clearly demonstrating the capability of activating without impacting the timed response of suppression systems.

**A.8.2.3.10.1(1)** This action can be compared to readying the space before suppression, such as initiating the closing of fire doors, dampers, and the like.

**A.8.2.3.10.1(4)** The releasing devices can be similar to those used for initiating fire doors, dampers, and the like.

**A.8.3** Compartmentation is provided to reduce the spread of fire and smoke between the telecommunications facility and other building occupancies.

**A.8.4.1.1** Alarm processing includes automatic or manual actions and responses to be performed as a result of a change in status of monitored alarm initiating devices, supervisory initiating devices, and trouble conditions.



**Table A.8.2.3.7 Recommended Sensitivity and Spacing of Smoke Detectors or Ports in Exhaust/Return Air Streams in Telecommunications Facilities with High Airflow Where Aisle Containment Is Present**

Intended Function	Low ACH — Up to 30		High ACH — Greater Than 30	
	Sensitivity	Spacing	Sensitivity	Spacing
Early detection	≤0.2%/ft	200 ft <sup>2</sup>	≤0.1%/ft	100 ft <sup>2</sup>
Operating dampers, doors, and shutters	≤1.5%/ft	400 ft <sup>2</sup>	≤0.75%/ft	200 ft <sup>2</sup>
Suppression agent release	>2.5% ≤4%/ft	400 ft <sup>2</sup>	>1.5% ≤3%/ft	200 ft <sup>2</sup>

- Notes:
- (1) See Fire Protection Research Foundation reports “Validation of Modeling Tools for Detection Design in High Air Flow Environments,” and “Validation of Modeling Tools for Detection Design in High Air Flow Environments — Phase II,” and FM Global report, “Experimental Data for Model Validation of Smoke Transport in Data Centers.”
  - (2) It is essential that the user understand the material in A.8.2.3.7 prior to the application of the recommended sensitivity and spacing in this table.
  - (3) The sensitivity levels for early detection should be considered to be pre-alarm levels.
  - (4) The sensitivity levels in the table should be considered to be above the ambient obscuration level. The listed sensitivity level should be added to the recorded average peak level in the ambient environment.

**A.8.4.1.3** In determining desired response time, whether or not a telecommunications equipment building could be un-staffed for any period of time should be considered as part of a response strategy as well as anticipated response time to an alert signal by owner or operator-designated personnel.

**A.8.4.2.2.2** Generally, alert signals from VEWFD systems should not be transmitted to the municipal fire department.

**A.8.4.2.2.5** Where hydrogen gas danger level, methane gas danger level, and battery room ventilation fan failure are not monitored by an alarm monitoring center complying with 8.4.1.4, they should be monitored by the fire alarm system as supervisory devices.

**A.8.4.2.3.3** Trouble signals should be responded to and remedied by local, trained telecommunications personnel.

**A.8.5.3.1.2.1** In general, two spot-type smoke detectors or ports per 6.1 m × 6.1 m (20 ft × 20 ft) building bay will be necessary. This size bay is typical but not universal in many traditional central offices. Installation of spot-type smoke detectors and ports should be determined on a case-by-case basis for buildings and enclosures that are different from the typical

building bay design. The spot-type smoke detectors or ports do not need to be located directly in the center of the bay but should be located so that they are exposed to the movement of smoke. The spot-type smoke detector or port should not be located within 0.9 m (3 ft) of supply duct registers. Locations selected should be visible from the floor and accessible for maintenance.

**A.8.5.3.1.2.2** In areas that have obstructions between the signal-processing or MDF equipment and the ceiling, and the obstructions are such that the free flow of smoke will be inhibited to the ceiling, sampling ports or spot-type smoke detectors should be located both at the ceiling level and below the obstructions to overcome this stratification. (Refer to NFPA 72.) In general, where stratification could be a concern, one high and one low spot-type smoke detector or port should be installed per building bay. See Figure A.8.5.3.1.2.2 for clarification.

**A.8.5.3.1.2.3** To increase performance, additional spot-type smoke detectors or ports should be provided in accordance with manufacturer's requirements. (Also see NFPA 72 for guidance on port and spot-type smoke detector placement.)

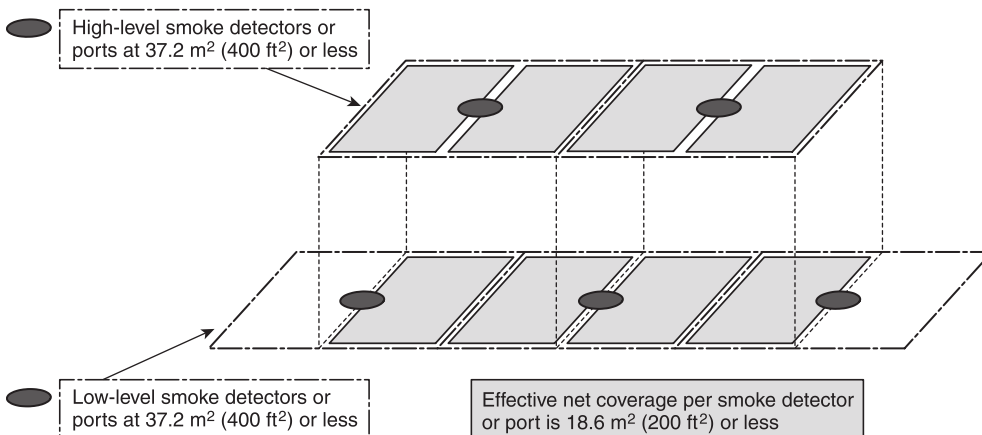
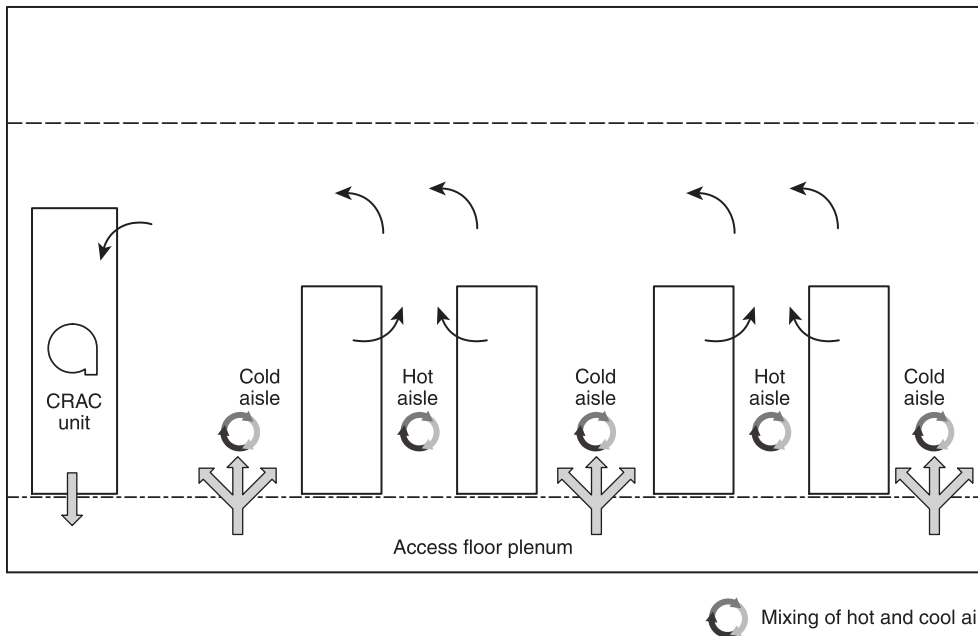

**Figure A.8.5.3.1.2.2 Staggered Layout of Sample Ports/Spot-type Smoke Detectors.**

**A.8.5.3.1.2.3(A)** Where heat containment systems are provided or retrofitted into the space, the port and spot-type smoke detector configuration should be evaluated for compliance with *NFPA 72* and the detection manufacturer's installation instructions. Heat containment systems are baffles that serve as a conduit between the equipment aisles or cabinets and the HVAC return air path(s). Where heat containments are not provided [See Figure A.8.5.3.1.2.3(A)(a)], there is a tendency for cooling air to mix with return air, which results in wasted energy in the HVAC system. Heat containments [See Figure

A.8.5.3.1.2.3(A)(b) and Figure A.8.5.3.1.2.3(A)(c)] prevent the mixing of heated air and cooling air, resulting in significant HVAC energy savings.

**N A.8.5.3.1.2.3(B)** Spot-type smoke detectors or ports at all paths where air returns within and leaves the space, such as at transfer grilles, ducts, or plenums, and prior to filtration, are intended to intersect with smoke before becoming scrubbed, highly diluted, or extracted from the building altogether.



**FIGURE A.8.5.3.1.2.3(A)(a)** Where Heat Containment Systems Are Not Provided, Significant Mixing of Heated and Cooling Air Occurs.

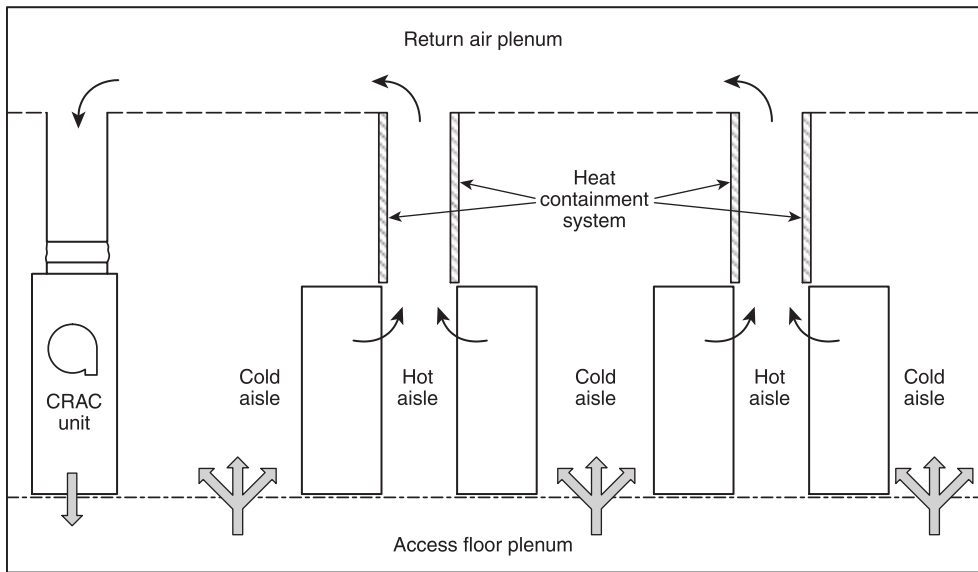

**FIGURE A.8.5.3.1.2.3(A)(b)** Heat Containment Systems Duct Heated Air to a Return Air Plenum.

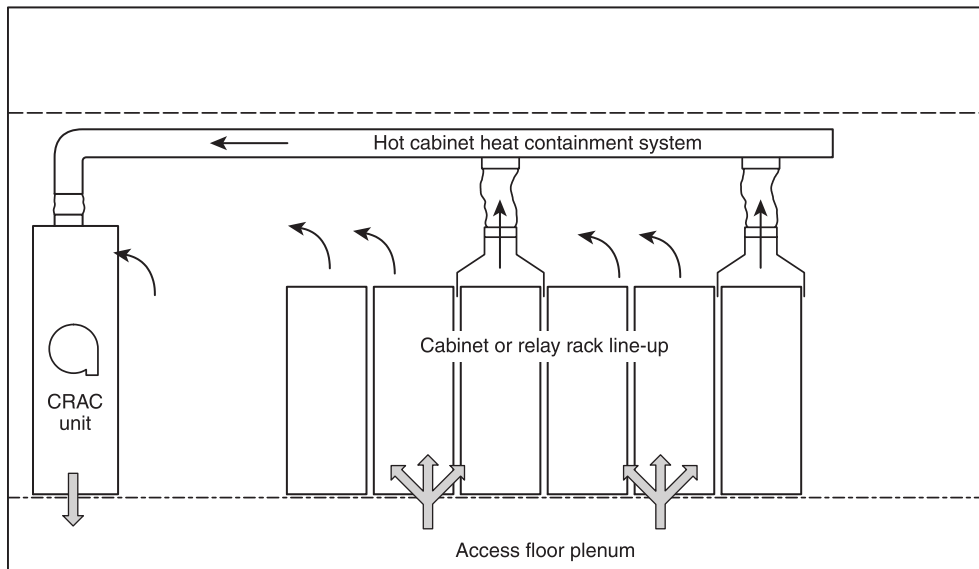

**FIGURE A.8.5.3.1.2.3(A)(c) Heat Containment Systems for High Heat Producing Bays or Cabinets Convey Heated Air to a Return Air Plenum.**

**A.8.5.3.1.2.4** The listed criteria at each sampling port should include the pipe air pressure, the airflow rate through that sampling port, the percentage of the total pipe flow through the sampling port, and the time needed for a smoke sample to be drawn from that sampling port to the detector.

**A.8.5.3.1.2.5** Because the listed sensitivity for an air-sampling smoke detection system is that measured at the detector rather than that at each individual sampling port on its piping network, the entire piping network should be evaluated to determine the effective sensitivity at a sampling port.

Sampling ports that draw in clean air will dilute smoke-laden air being drawn in by other ports. The accumulative effect of clean air being drawn through some ports causes dilution that reduces the effective sensitivity of other ports on the same pipe network. Conversely, the accumulative effect of smoke being drawn into multiple sampling ports causes the overall effective sensitivity of the air-sampling system to increase beyond the sensitivity expected at a single sampling port.

The effective sensitivity of a sampling port is a function of the total number of ports on a piping network and the percentage of those sampling smoke-laden air. As the number of ports sampling clean air increases, the effective sensitivity at individual ports on an air-sampling smoke detection system is reduced to less than the listed sensitivity of the detector unit.

The following two examples show a best and a worst credible scenario:

- (1) Assuming all sampling ports will sample smoke-laden air, with all the ports in one common interior area with the smoke being uniformly mixed throughout the space by an HVAC system, the effective sensitivity of each sampling port is approximately equal to the listed sensitivity of the detector unit.
- (2) Assuming that only one sampling port will sample smoke-laden air, and assuming a balanced piping network design where there is equal airflow, and thus equal sensitivity, at each sampling port, the effective sensitivity of each

sampling port is the listed sensitivity of the detector unit multiplied by the total number of sampling ports.

**A.8.5.3.2.1.2** In general, one spot-type smoke detector or port per 6.1 m × 6.1 m (20 ft × 20 ft) building bay will be necessary. This size bay is typical but not universal. The spot-type smoke detectors or ports do not need to be located directly in the center of the bay but should be located so that they are exposed to the movement of smoke. The spot-type smoke detector or port should not be located within 0.9 m (3 ft) of supply duct registers. Locations selected should be visible from the floor and accessible for maintenance.

**A.8.5.3.2.1.5** The listed criteria at each sampling port should include the pipe air pressure, the airflow rate through that sampling port, the percentage of the total pipe flow through the sampling port, and the time needed for a smoke sample to be drawn from that sampling port to the detector.

**A.8.5.3.2.2.2** See *NFPA 72* for flame detector selection considerations.

**N A.8.5.3.4.1.1** Sampling holes or spot-type smoke detectors should be located where smoke is more likely to migrate. For example, in an unventilated (i.e., sealed) cabinet, detection should be located within the top 10 percent, whereas in a ventilated cabinet, detection should be provided where the ventilation exits the cabinet. In a naturally vented cabinet, this area is the upper ventilation vent.

**A.8.6.1** This section provides for the use of automatic or manual fire suppression equipment as tools available to be used as fire safety elements in a fire protection plan for a telecommunications facility. Telecommunications facilities have achieved an excellent fire loss record due to the high standards of construction, compartmentation of hazards, and high quality of telecommunications equipment. This high record of reliability has been achieved mostly without the use of automatic extinguishing systems. Automatic suppression should be considered when other fire protection elements cannot be employed. Careful consideration should be made to recognize

the impact the agent could have on the energized telecommunications equipment.

**A.8.6.2.1.1** Automatic fire suppression systems provided in telecommunications facilities should be selected with due consideration of the hazards being protected and the impact of the agent on energized telecommunications equipment or on unprotected emergency responders performing depowering functions. Detection and actuation systems should be periodically reviewed in order to avoid unwanted discharges of the automatic fire suppression systems. Accidental discharge of extinguishing agents can cause damage to equipment or danger to personnel. Fire suppression agents should not cause severe damage to the telecommunications equipment. Suppression agents such as those containing dry chemical agents or corrosive wet agents in fixed systems should not be used in any area containing telecommunications equipment.

△ **A.8.6.2.2.1** Wet pipe, dry pipe, and pre-action systems are acceptable for use in the protection of technical support, administrative and buildings services, and support areas of telecommunications facilities, but they are not recommended for the power area, main distributing frame (MDF) areas, signal-processing area, and standby engine areas. The introduction of water piping in telecommunications power areas, MDF areas, or signal-processing areas should be carefully considered. Water is a risk to telecommunications signal-processing equipment and, by extension, to public safety.

The use of pre-action, double-interlocked sprinklers will minimize the risk of inadvertent water discharge.

Spilled water, sprinklered water, or water mist from a suppression system can provide voltage sources with a fault path to ground leading to equipment damage or a personnel hazard.

**A.8.6.2.3.1** Piping systems installed to deliver clean agents into telecommunications equipment areas should have particular attention paid to internal cleaning of the piping. Any debris discharged into the telecommunications equipment area can cause catastrophic damage to the telecommunications equipment. All piping systems should be cleaned internally after fabrication to prevent discharge of debris. Cleaning should be in accordance with the requirements of NFPA 2001 and manufacturer's recommended guidelines.

**A.8.6.2.4.1** Piping systems installed to deliver halon systems into telecommunications equipment areas should have particular attention paid to internal cleaning of the piping. Any debris discharged into the telecommunications equipment areas can cause catastrophic damage to the telecommunications equipment. All piping systems should be cleaned internally after fabrication to prevent discharge of debris. Cleaning should be in accordance with the requirements of NFPA 12A and manufacturer's recommended guidelines.

**A.8.6.3.1.3** Dry chemical agents and corrosive liquid agents will contaminate the signal-processing equipment and cause damage to the terminals and connectors. Experience has shown that such contamination and damage can be catastrophic to the equipment. It is recommended that any occupancy near or adjacent to telecommunications equipment areas not have dry chemical or corrosive liquid extinguishers installed.

**A.8.6.3.2** All pipes carrying water (e.g., domestic water lines, roof drain lines, sanitary drain lines) in or around telecommu-

nications equipment should be monitored for water leaks to prevent water damage and loss of network reliability. If possible, water pipes should be routed so as to avoid installation above telecommunications signal-processing equipment areas, main distributing frame areas, and power equipment areas. If it is not possible to avoid these locations, consideration should be given to the inclusion of secondary containments such as coaxial pipe enclosures and the like. In areas of the country where freezing temperatures occur, water pipes and wet-type sprinkler systems should be avoided in standby engine rooms — if the engine runs for a protracted length of time, the water in the piping could freeze and rupture the pipe. All hose connections should be installed outside telecommunications areas.

**A.8.7.1** Where properly designed, installed, tested, and maintained, smoke management systems, including smoke control systems and smoke removal systems, should be recognized as an effective means to prevent smoke from spreading to noninvolved areas in low heat release rate fires, to minimize damage, and to facilitate search, manual fire fighting, and cleanup operations.

A system designed, installed, and maintained to provide one level of protection will not, in every case, also provide another level of protection that could be necessary for a hazard area.

Where smoke or combination fire/smoke dampers are installed in separations between hazard areas with varying smoke detection performance, additional review should be performed and/or operational strategy provided to ensure that the selected smoke control sequence is correct. While it is not recommended, it is possible that two compartments share an HVAC system. The more important area will have a smoke detection system with higher detection performance. It is possible that smoke can drift between compartments from a fire in the compartment with less sensitive smoke detection and be detected by the more sensitive smoke detection in the adjacent compartment. This should result in the dampers closing. The smoke exhaust system should start only when the smoke condition is verified in the compartment experiencing fire conditions. The improper smoke exhaust operation can result in unintended damage.

△ **A.8.7.2** Smoke management for telecommunications facilities is different from smoke management applications for high-rise buildings or tall atria as prescribed in NFPA 92 and NFPA 204. Paragraph A.8.7.2 is intended to provide design guidance on the application of smoke management systems for telecommunications facilities given the unique applications. Note in this application, smoke management systems are not intended for life safety and emergency egress of building occupants as they are in other industry applications. Given that, the requirements of those other standards intended to support life safety functions are not intended to apply to the application to telecommunications facilities. The reasons for smoke management systems in this application are as follows:

- (1) To allow fire department personnel or operating personnel sufficient visibility to approach, locate, depower equipment, and extinguish a fire without depowering the entire network facility
- (2) To prevent damage to equipment and loss of emergency communication systems
- (3) To provide means for rapid removal of smoke to permit continued cooling operations and prevent indirect

damage to equipment from thermal effects and eventual loss of emergency communication systems

The smoke management system is intended to provide emergency removal of smoke **contaminants** from network equipment and power spaces in telecommunications buildings. Smoke removal is considered an important priority after a fire has been detected. Given the construction of the materials typically present in telecommunications spaces, damaging smoke and its subsequent removal require a higher priority than continued progression of a Class C fire, assuming the fire suppression (if present) is unable to extinguish the source. The fires associated with telecommunications switching equipment rooms are typically Class C, slow-burn fires (e.g., electrical fires or energy-augmented fires), involving little to no flame but with large amounts of smoke generation. It is desirable that the network equipment remain in operation throughout the duration of a fire. Because these facilities often provide emergency communications, in only the most extreme cases should the facility be completely depowered as result of a fire or disaster. Smoke management systems installed in signal-processing areas are intended to protect the electronic equipment from being exposed to the caustic and damaging contents of the smoke, thereby preventing circuit bridging, circuit pack failures, and large loss of equipment within these spaces. In addition, the smoke management system is intended to maintain the smoke layer above a minimum height necessary to allow depowering operations by operating personnel and local fire-fighting authorities. The smoke management system also should serve as a smoke purge system to remove smoke after a fire by means of dilution ventilation.

Typical design objectives of the smoke management system are as follows:

- (1) To remove smoke from the signal-processing areas
- (2) To remove smoke from design fires associated with cabling, trays, equipment, and associated packaging materials that **might** be in the space being protected
- (3) To provide the necessary makeup air
- (4) To remove smoke quickly enough to maintain the smoke above equipment racks during the worst-case design fire scenario to protect the equipment from smoke damage and allow for depowering efforts

Three distinct design approaches are commonly used for the smoke management systems used in telecommunications facilities, as follows:

- (1) Smoke management — removal of smoke products during a fire event (during depowering efforts)
- (2) Smoke removal — rapid removal of the smoke products after a fire event via dilution ventilation
- (3) Smoke control — control of the spread of smoke to rooms that are not involved in the fire event; takes place from initial fire alarm through completion of the smoke removal of the affected zone until normal operations resume

The design approach for smoke management should be based on NFPA 92 using the following criteria:

- (1)  $t^2$  design fire.
- (2) Very slow growth fire, >600 sec.
- (3) Make-up air quantities should be permitted equivalent to the exhaust air quantities for a given space.

The design approach for smoke removal should be based on dilution ventilation sufficient to remove smoke within a time frame acceptable to the owner and within sufficient time to prevent thermal failure of signal-processing equipment after the fire has been extinguished. Dilution ventilation can be calculated using the logarithmic calculation found in *Principles of Smoke Management*. To take a fire alarm system out of alarm, the smoke concentration needs to be diluted below the sensitivity level of the smoke detectors. The design should be permitted to be based on the worst-case calculation from a smoke management or smoke purge design approach.

Calculations for design fire cases should be permitted to be derived from generally accepted engineering practice.

It is important for the system designer to be aware of the limitations for any equations used in the design. Some of them **might** be applicable only under a limited range of conditions that **might or might** not be present in the job being designed.

Typical assumptions used in a performance-based design can include the following:

- (1) Good housekeeping practices are strictly followed, in which no amounts of combustible or flammable materials are stored in the critical equipment rooms.
- (2) No combustible materials are located under raised floors.
- (3) Telecommunications equipment or cabling involved in a fire will be depowered within 1 hour of an EWFD alarm.
- (4) The smoke management system will operate after the fire suppression system (if present).
- (5) Airflow is designed for smoke management during a fire event to maintain the smoke layer above equipment racks; airflow is also designed to be of sufficient rate to completely remove smoke within sufficient time to prevent thermal failure of the network equipment involved.

Smoke management systems should be provided in signal-processing equipment areas.

Refer to NFPA 92 and NFPA 101 for requirements of pressure control to ensure proper operation of doorways during system operation.

Smoke management systems should be permitted to be designed using applicable design calculations found in NFPA 92, NFPA 204, or *Principles of Smoke Management* using design fires in all spaces served by the smoke management system.

Equipment suitable for its intended use and the probable temperatures to which it is likely to be exposed should be permitted. Exhaust fans UL-listed for smoke management/control systems and carrying the UL-705 label or certified by the manufacturer to meet the minimum temperature and time requirements should be permitted. Smoke exhaust fans should be tested following ASHRAE 149.

Smoke dampers should be listed in accordance with UL 555S. Combination fire and smoke dampers should be listed in accordance with UL 555 and UL 555S. Dampers should be suitable for their intended use and the probable temperatures to which they are likely to be exposed. When present, dampers should have override capability for smoke management system operations. Damper override should not be permitted to close until temperatures exceed 177°C (350°F) in the duct. Dampers should be provided with limit switches

used for verification of damper position in the control system and to ensure safe HVAC equipment operation.

Duct materials should be selected and designed to convey smoke, withstand additional pressure (both positive and negative) by the supply and exhaust fans when operating in a smoke-control mode, and maintain their structural integrity during the period for which the system is designed to operate. Ducts suitable for their intended use and the probable temperatures to which they are likely to be exposed should be permitted.

Control systems listed in accordance with UL 864 category UUKL for their intended purpose should be permitted.

A fire fighters' smoke-control station (FSCS) per Annex H of NFPA 92 should be permitted. On/off/auto selectable switches (one per zone) should be permitted. An FSCS located behind locked cover for protection in public areas should be permitted. An FSCS located adjacent to a fire alarm panel or as directed by AHJ should be permitted.

A single control system or fire alarm system coordinating the smoke-control functions, FSCS, and any other related systems with the operation of the building HVAC systems and smoke-control equipment should be permitted.

A strobe light mounted at every entry point and labeled "EMERGENCY SMOKE MANAGEMENT SYSTEM IN OPERATION — DO NOT ENTER" at each zone served by the smoke management system should be permitted.

**A.8.7.2.2** Makeup air inlets should be designed so that the velocity of the supplied air does not exceed 61 m/min (200 ft/min) and to take maximum use of the mixing and diluting effects created. If air enters the smoke layer above the interface, it should be accounted for in the exhaust calculations. Where outside air is used, consideration should be given to conditioning the outside air to provide an environment that would be similar during regular operations, to avoid temperature shocks to electronic telecommunications equipment.

**A.8.7.2.3** Consideration should be given to using exhaust point(s) to reduce the possibility of smoke being drawn into noninvolved telecommunications equipment. Exhaust openings should be designed and positioned to take maximum use of the mixing and dilution effects created by the airflow in the room.

**A.8.7.2.5** Periodic testing and maintenance is essential to ensure operation of the smoke management systems. For guidance, see NFPA 92 and NFPA 204. Periodic testing frequency should be based on criticality of the smoke management system to service continuity and life safety.

**A.8.7.3** The design of the power supply and controls of the smoke management system should preclude unintentional shutdown of the smoke management system (see Section 6.5).

To prevent smoke migration into telecommunications areas during fire department overhaul and to facilitate cleanup, means for smoke removal should be provided. Examples are provisions of special openings for use by fire department smoke ejectors, access panels in walls, and roof vents for gravity venting.

**A.8.7.4.2** The design of the power supply and controls of the smoke management system should preclude unintentional shutdown of the smoke management system (see Section 6.5).

**A.8.8.1** Section 8.8 describes the procedures and test methods used to quantify ignition and fire resistance in telecommunications equipment.

Provision of telecommunications equipment that is resistant to ignition and subsequent fire spread has a direct impact on the frequency and severity of fires in telecommunications facilities.

**A.8.8.2.8.4** ANSI/UL 568 does not currently have any requirements for nonmetallic cable trays in plenums.

**A.8.8.3** UL 60950-1, *Information Technology Equipment — Safety — Part 1: General Requirements*, specifies the fire performance of the materials used in making the equipment and therefore provides a level of protection. However, UL 60950-1 does not require fire safety performance testing of the final equipment configuration as Telcordia GR-63-CORE, *Network Equipment Building System (NEBS) Requirements: Physical Protection*, does, and does not provide assurances that the fire will not continue to propagate past a single piece of equipment as required by GR-63.

**A.9.1** Inadequate housekeeping provides potential fuel for an ignition source and allows combustibles to be closer to potential ignition sources. The basic prevention is prompt disposal of combustible materials or safe storage of these materials and periodic inspections to verify this is being done.

Telecommunications facilities should implement a level of fire prevention measures and should be constructed, maintained, and occupied in a way that reduces the likelihood of ignition and the spread of a fire by minimizing the ignition potential and reducing the fire load.

**A.9.1.1** All combustibles should be kept to a minimum. Fire prevention recommendations apply to both owned and leased structures.

**A.9.1.2** Such combustibles within unprotected areas and having a heat release rate greater than 500 kW represent a potential hazard even for noncritical areas of telecommunications facilities (see annex material in NFPA 72 for examples of heat release rates; for guidance concerning such storage, see NFPA 1 and NFPA 241). If such combustibles cannot practically be stored within protected areas, other prevention measures in this standard should be implemented to ensure that the buildup of or the amount of combustibles is limited or otherwise kept to a minimum. Areas near the ventilation system intake, or any openings (e.g., equipment doors and egress routes), are areas of greatest concern because these are places a fire could enter a building.

**A.9.1.3** If the primary heating source is inadequate, the building management should take appropriate permanent action to correct the heating deficiencies.

Where portable space heaters are necessary for work activities or due to extraordinary problems with the HVAC system, they should include the following features:

- (1) Electrically powered
- (2) Listed
- (3) De-energized upon tilt or tipover
- (4) Illuminated "power-on" pilot light
- (5) Variable temperature control
- (6) Building management approval
- (7) Limited to temporary use of no more than 30 consecutive days

**A.9.1.4** Heat-producing appliances can be located in an established break or food services area within a facility. The intent of this restriction is to prohibit the presence and use of appliances not directly related to the support and operation of telecommunications equipment, such as portable heaters, mug warmers, coffee pots, hot plates, microwave units, and refrigerators. These and other unnecessary potential sources of ignition should not be located in any telecommunications equipment area, computer room, individual office spaces, individual cubicles, storage areas, or shipping areas. It is not the intent of this section to restrict the intermittent use of portable heat-producing tools necessary for installation and maintenance activities within the telecommunications facility.

**A.9.1.5** Smoking is defined as the carrying or use of a lighted pipe, cigar, cigarette, tobacco, or any other type of smoking substance. Examples of telecommunications equipment areas and support buildings include signal-processing areas; power and battery areas; standby engine areas, warehouse, combustible storage, staging areas; and computer rooms.

**A.9.1.5.2** The fire risk analysis should include consideration of the following criteria to protect the network:

- (1) Noncombustible ash trays
- (2) Noncombustible waste receptacles
- (3) Ignition-resistant furnishings
- (4) Commensurate detection and/or suppression
- (5) Minimum 1-hour fire separation of the area

**A.9.1.6** The objectives of these actions should be to reduce ignition risks and to provide appropriate fire prevention intervention strategies. Where soldering irons, heat guns, glue guns, and other similar heat-producing tools are used, they should be attended at all times when in use. Additionally, these tools should be de-energized and safely stored when not in use.

**A.9.1.7** Flammable and combustible liquids such as paints, solvents, and other lubricants generally should not be permitted in telecommunications equipment facilities.

**A.9.1.7.3** Noncombustible compressed gases within telecommunications equipment areas should follow the Compressed Gas Association guide for safe handling, CGA P-1.

**A.9.2** *NFPA 70* does not cover "Installations of communications equipment under the exclusive control of communications utilities located outdoors or in building spaces used exclusively for such installations." [See Section 90.2(B)(4) of *NFPA 70*.]

**A.9.3.2** A temporary connection is considered to be one that is less than 30 days in duration. An example of a flexible electric cord is an extension cord. If additional electrical demand is needed, the local management should be consulted.

**A.9.4** Construction and alteration projects should be carefully reviewed by management to ensure conformance with all codes, regulations, and company standards. The delivery, storage, installation, testing, and cleanup associated with the installation of telecommunications equipment should be performed in a manner that exhibits the highest degree of fire safety procedures. The vendors, installers, and contractors associated with the installation of telecommunications equipment should comply with the safety standards of the telephone company during the installation of such equipment.

**A.9.4.3** Where tarps are used to cover combustible construction, alteration, and installation materials, they should be listed as fire-resistive tarps.

**A.9.4.4** NFPA 25, NFPA 1, and other appropriate standards can be referenced for additional information. The delivery, storage, construction, and cleanup associated with building construction and alteration work should also be performed in a manner that complies with the telecommunications company policies. The activities of building construction contractors should be regulated by policies of the telecommunications company.

**A.9.4.6** Building maintenance and janitorial staff should consider all the activities that would increase the fire load or ignition probability and should take appropriate steps to limit or remove these potential hazards.

Examples of potential hazards include flammable cleaning solvents, aerosol products, worn or frayed extension cords, improperly sized extension cords, improperly maintained motors, and improperly grounded equipment.

**A.9.8** For new cabling installations, ac, dc, and telecommunications cables should be run in separate paths and not mixed. Where practical, unused or dead cables should be mined (removed) and discarded. Care should be taken during the removal process so as to protect the existing live cables from damage.

Infrared thermography or other like technology can be used to detect hot spots in telecommunications operations. Thermography scanning should be conducted for power boards, rectifiers, batteries, power room bus connectors, switchgear, ac/dc, and primary power supply.

**A.9.8.1** The intent is to separate major cable distribution systems. In-bay or in-cabinet wiring should be installed in accordance with manufacturer's instructions.

**A.9.8.3** Care should be taken during the removal process so as to protect the existing live cables from damage.

**A.10.1.1.3** The plan is intended to ensure the safety of employees and all occupants of the facility.

**A.10.1.1.5** The intent of the exercise is to ensure that management and staff can implement and work with the plan and incorporate lessons learned from the exercise into an updated plan.

**A.10.2** The telecommunications company should ensure that employees receive periodic and regular orientation pertinent to their assigned responsibilities involving the following:

- (1) Facility evacuation
- (2) Facility fire prevention measures
- (3) Facility fire detection systems
- (4) Alarm processing
- (5) Fire suppression or response to fire incidents

Fire drills should be conducted annually at the facility for all employees assigned to the facility.

See NFPA 101 for exemptions for number of occupants.

**A.10.3** Figure A.10.3 is an example of a pre-fire plan drawing.

**A.10.3.2** Fire service orientation and information might include the review of the telecommunications equipment placement, the depowering issues, and how to perform them.

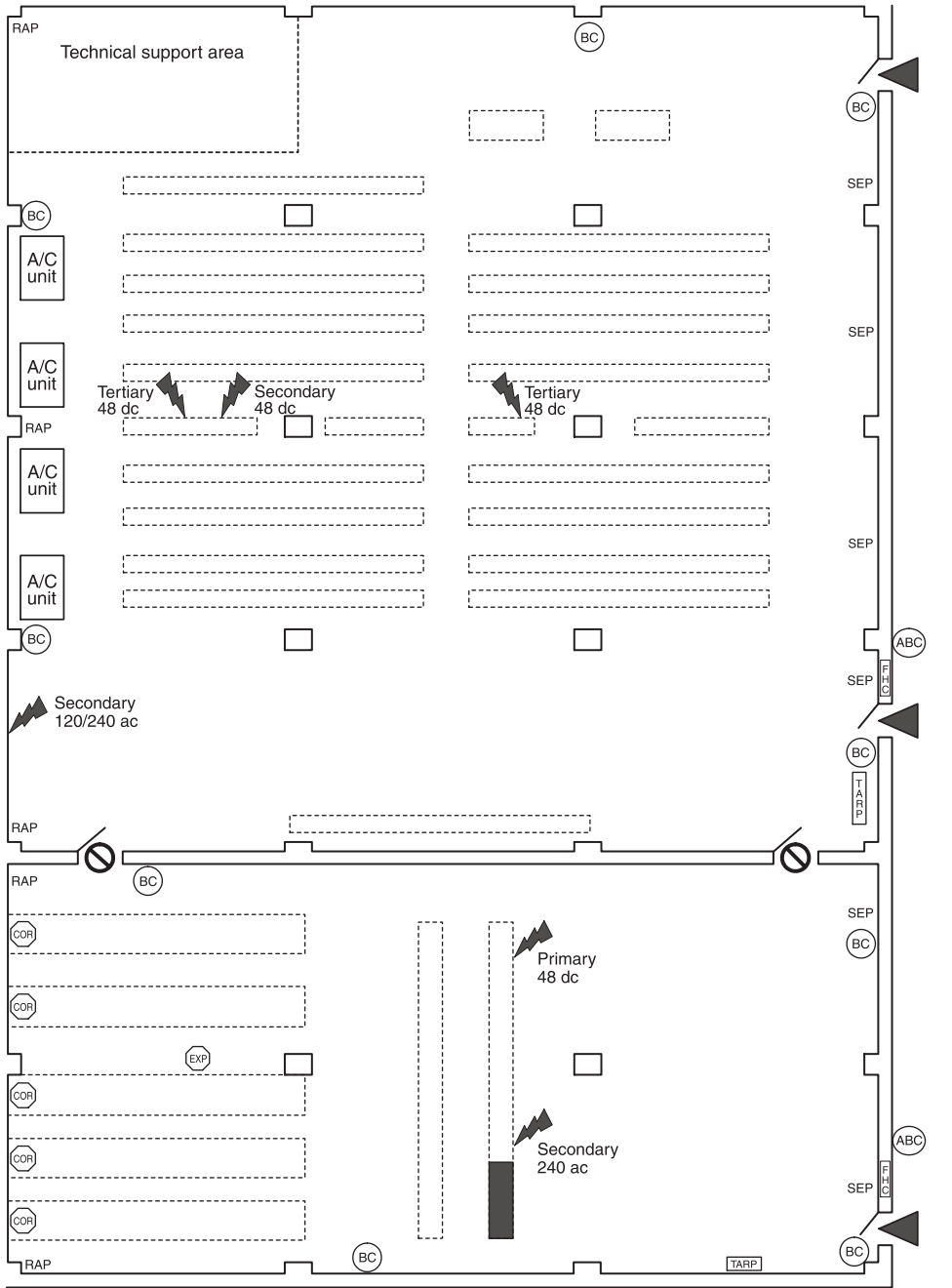

Legend

- |                          |  |                          |
|--------------------------|--|--------------------------|
| Corrosive material       | Telephone equipment, etc.                | RAP Replacement air port |
| No fire-fighting access  | Fire hose cabinet                        | Tarpaulin                |
| Contamination danger     | Equipment with PCB-containing components | ABC extinguisher         |
| Fire-fighting access     | SEP Smoke exhaust port                   | BC extinguisher          |
| Power supply and voltage |  |                          |
| Explosive gas potential  |  |                          |

▲ FIGURE A.10.3 Example of a Pre-Fire Plan Drawing.



This orientation can also include suggestions regarding strategy and tactics to confine, suppress, and limit an incident's impact on telecommunications services. Additionally, presence and operation of unique room or building protection systems, such as smoke management systems, should be reviewed.

**A.10.4** When developing the procedure for depowering, the possible effects of depowering on the continuity of communications services should be considered.

**A.10.4.1** In large telecommunications facilities where there are multiple switching systems or separate switching and transport signal-processing equipment, a full dc depowering effort could have a much broader impact on telecommunications services than is warranted. Therefore, consideration should be given to clearly identifying signal-processing areas with individual zones and fuses or circuit breakers on the dc power board that feed those zones. Accordingly, if fire or deflagration occurs in one such signal-processing equipment zone, selectively depowering only that zone mitigates the problem and allows the remaining systems to continue functioning normally. The first switching system entity installed in a facility might be one zone, while subsequent switching system entities would be installed as separate zones. The first major transport system and related equipment installed in a facility might be identified as one transport zone, while subsequent systems would be identified as separate zones. Due to the higher voltages produced by inverters in the power equipment area feeding certain equipment types in the signal-processing equipment areas, inverter-supplied equipment might be identified as a separate zone to improve the safety afforded to fire responders who might need to depower a particular zone. Color coding is one effective means of zone identification that has received wide acceptance by fire departments.

**A.11.2.3** Due to the unoccupied status of these facilities, portable fire extinguishers are not considered necessary for fire protection.

## **Annex B Performance Test Procedures for Very Early Warning and Early Warning Fire Detection Systems**

*This annex is not a part of the requirements of this NFPA document but is included for informational purposes only.*

### **B.1 Introduction.**

**B.1.1 Scope.** Performance of the tests described in this annex can result in the release of noxious fumes, the presence of localized heat, and the introduction of a fire hazard to the tested area. Precautions should be taken to protect personnel from these potential hazards. It is the responsibility of the testing personnel to conduct testing in a manner that complies with federal, state, and local health and safety regulations.

**B.1.1.1** These tests are intended to simulate the small amounts of smoke that would be created in the early stages of a fire in a telecommunications equipment area. If an actual fire were to produce the amounts of smoke produced by these tests, telecommunications companies would want to be alerted by the fire alarm system.

**B.1.1.2** The tests represent a good balance between the desire to use smoke sources that are representative of the types of fires that have occurred in telecommunications equipment areas and the desire to minimize the introduction of smoke

that can cause damage to operating telecommunications equipment in the area.

**B.1.2 Objectives.** These tests are also intended to meet the general objectives listed in B.1.2.1 through B.1.2.4.

**B.1.2.1** The tests are intended to be repeatable, in that a consistent quantity, temperature, and color of smoke is produced each time the test is performed.

**B.1.2.2** The tests are intended to use test equipment that can be set up quickly in actual telecommunications facilities (i.e., in situ).

**B.1.2.3** The tests are intended to prevent or minimize the potential for smoke damage to the telecommunications equipment in the room under test. They should create little or no corrosive products of combustion.

**B.1.2.4** The tests are intended to avoid the creation of large amounts of smoke and gas that could pose a health threat to personnel in the test area.

### **B.2 Heated Wire Test.**

**B.2.1** This test uses an electrically overloaded PVC-coated wire to simulate the early stages of a fire. Although a PVC wire is used, hydrogen chloride vapor is unlikely to be produced in quantities significant enough to be of concern, if the test procedures herein are followed, due to the relatively low temperatures reached. If the current is applied for a longer time, or if the wire sample is shorter than stated, small quantities of hydrogen chloride can be generated. In either event, a clearly perceptible odor that should dissipate in short time is produced by the test.

The tests are based on the test specified in Section A.3 of BS 6266. The principal differences for some tests include the use of a regulated dc power supply and different wire, electrical load, and wire length.

Users are directed to Table B.2.1 to select the parameters to be used during the testing.

The test parameters to be used should be selected based on the detection system performance levels dictated by the performance-based analysis.

**B.2.2 Test Apparatus.** The test apparatus consists of the items listed in B.2.2.1 through B.2.2.4.

**B.2.2.1 Wire.** Table B.2.1 lists four options for wire selection and test parameters for the users to select. Test wire should be cut cleanly to the length specified in Table B.2.1.

**B.2.2.2 Wire Mounting.** The wire should be arranged by placing it on a noncombustible, nonconductive board, or suspending it on a noncombustible, nonconductive support. The wire should be arranged so that there are no kinks or crossovers where localized higher temperature heating can occur.

**B.2.2.3 Power Supply and Leads.** A regulated dc power supply should be capable of supplying a current of 0 to 30 amperes at 0 to 18 volts dc (i.e., Kenwood Model XL6524E-D). The lead wires between the power supply and the test wire(s) should be 10 AWG, 3.25 m (10.66 ft) long to avoid unacceptable voltage drop.

**B.2.2.4 Stopwatch.** A stopwatch or clock accurate to 1 second should be used.

△ Table B.2.1 Heated Wire Test Parameters

Parameter	BS 6266 Test		Modified BS 6266 Test: Two 1 m Wires in Parallel	North American Wire Test: North American Wire
	2 m Wire Test	1 m Wire Test		
Wire specs	10 strands of 0.1 mm diameter (38 AWG) tinned copper wire insulated with PVC to a radial thickness of 0.3 mm.	Total cross-sectional area of conductor is 0.078 mm <sup>2</sup> (28 AWG). Insulated with PVC to a radial thickness of 0.3 mm.	Wire is very flexible due to stranded construction and highly plasticized insulation.	A single strand of 22 AWG copper wire, insulated with PVC to a diameter of 1.19 mm (0.047 in.). This wire is stiffer than the BSI wire due to the single-strand construction and the minimally plasticized PVC insulation.
Smoke characterization	Smoke is very light (barely visible). HCl vapor is unlikely to be produced due to the low temperature achieved in the wire. The primary constituent of the smoke is plasticizer.	More visible smoke than the 2 m test, but still very light smoke. Due to the higher temperature in the wire, a very small amount of HCl vapor will be produced.	More visible smoke than the 2 m test or the single wire 1 m test but still very light smoke. Due to the higher temperature in the wires, a small amount of HCl vapor will be produced.	More visible smoke than the BSI wire tests but still very light. A minor amount of HCl is produced but for a shorter duration than the BSI wire tests.
Test period	180 seconds	60 seconds	60 seconds	30 seconds
Electrical load	Constant voltage — 6.0 volts dc, current varies from 0 to 15 A during the test due to changing resistance in the wire.	Constant voltage — 6.0 volts dc, current varies from 0 to 15 A during the test due to changing resistance in the wire.	Constant voltage — 6.0 volts dc, current varies from 0 to 30 A during the test due to changing resistance in the wire.	Constant current of 28 A. Voltage varies from 0 to 18 volts dc during test due to changing resistance in the wire.
Pass/fail criteria	Fire detection system should “respond” within 120 seconds of the end of the test period.		“Alert” or “pre-alarm” signal within 120 seconds of the end of the test period.	

### B.2.3 Test Procedure.

**B.2.3.1** The test should be performed in the room in which the detection system is installed, with all normal ventilation fans (e.g., fans internal to equipment, room ventilation fans) operating. Testing should also be performed with the fans turned off to simulate the potential for fan cycling and/or a power failure. This does not preclude testing required by *NFPA 72*.

**B.2.3.2 Detector Programming.** The detector alarm sensitivity setting (i.e., pre-alarm or alarm) used during the test should be identical to those used during normal operation of the system. Alarm verification or time delay features should be disabled during the test to permit the detector response to be annunciated immediately upon activation.

This testing is intended to verify that the detectors “see” smoke in sufficient concentrations to reach the specified alarm levels. Because the test produces a small amount of smoke for a brief period of time (i.e., a puff of smoke), the use of the alarm verification or time delay features would likely result in the detector not reaching the specified alarm levels. In a “real-world” fire, the smoke would continue to be produced as the fire grows, permitting the detector to reach alarm. If these features are disabled during the testing, they should be

enabled at the conclusion of the testing before leaving the room.

**B.2.3.3 Test Locations.** Test locations should be selected by considering the airflow patterns in the room and choosing challenging locations for the tests (i.e., both low airflow and high airflow can be challenging). If possible, the locations and elevations of the test apparatus should be varied to simulate the range of possible fire locations in the room. Locations where the smoke would be drawn directly into the telecommunications equipment cooling ports or fans should be avoided. Locations where the smoke would be entrained into the air exhausting from an equipment cabinet are acceptable.

**B.2.3.4 Positioning.** The test apparatus should be positioned at the test location, and the test equipment should be secured to prevent damage.

**B.2.3.5 Preparation.** The test wire should be prepared by carefully removing not more than 12 mm (½ in.) of the insulation from each end of the sample so that the conductor(s) is not nicked.

**B.2.3.6 Mounting.** The wire should be mounted on the insulating material so that there are no kinks or crossovers in the wire.

**B.2.3.7 Setting.** The power supply should be set to supply either a constant voltage or constant current as shown in Table B.2.3.7.

**B.2.3.8 Connection.** The ends of the test wire(s) should be connected to the power supply leads.

**B.2.3.9 Test.** When all other preparations are complete, the power supply should be switched on for a period shown in Table B.2.3.7. After the appropriate current application time, the power supply should be turned off, and the test results should be observed and recorded.

To avoid burns, the wire should not be touched during the test, or for 3 minutes after turning off the power supply. If the wire is located close to HVAC registers or equipment exhaust ports, the airflow can cool the wire and result in inadequate production of smoke. In this event, either the apparatus should be repositioned or the wire should be shielded from the airflow.

**B.2.3.10 Test Sequence.** The test should be repeated at least three times for each HVAC condition, with the test apparatus placed in a different location in the room each time. If possible, the elevation of the test apparatus should be varied.

**B.2.3.11 Pass/Fail Criteria.** The pass or fail criteria for the VEWFD system should be as indicated in Table B.2.1.

### B.3 Lactose–Potassium Chlorate Test.

**B.3.1 Description.** The lactose–potassium chlorate test is one of the test methods specified in BS 6266 with modifications to the mass of mixture used for North American conditions. A mixture of 50 percent by weight of lactose and 50 percent by weight of potassium chlorate is ignited by a long-handled butane lighter to produce a small, vigorous flame and clean white smoke.

**B.3.2 Test Apparatus.** The test apparatus should consist of the items listed in B.3.2.1 through B.3.2.6.

**B.3.2.1 Crucible or Open Cup.** A noncombustible (i.e., metal, silica, or porcelain) crucible or similar cup-shaped item should be used to hold the mixture of lactose and potassium chlorate during combustion.

**B.3.2.2 Support.** A noncombustible surface should be used to hold the crucible upright and to insulate it from the supporting surface below.

**B.3.2.3 Scale.** A scale accurate to 0.1 g should be used for weighing the required mass of lactose and potassium chlorate.

**B.3.2.4 Stopwatch.** A stopwatch or clock accurate to 1 second should be used.

**B.3.2.5 Igniter.** A long-handled butane lighter (i.e., one used to light a barbecue grill) should be used.

**CAUTION: DO NOT USE AN ORDINARY CIGARETTE LIGHTER — BURNS COULD RESULT.**

**B.3.2.6 Ignition Mixture.** A mixture composed of equal masses of lactose and potassium chlorate should be used. (This mixture is approximately 1.4 volumes of lactose to 1 volume of potassium chlorate.) For testing EWFD systems, the mass of lactose/chlorate mixture should be 4.0 g.

### B.3.3 Procedure.

**B.3.3.1 Detector Programming.** The detector alarm sensitivity setting (i.e., pre-alarm or alarm) used during the test should be identical to those used during normal operation of the system. Alarm verification or time delay features should be disabled during the test to permit the detector response to be annunciated immediately upon activation.

This testing is intended to verify that the detectors will “see” smoke in sufficient concentrations to reach the specified alarm levels. Because the test produces a small amount of smoke for a brief period of time (i.e., a puff of smoke), the use of the alarm verification or time delay features would likely result in the detector not reaching the specified alarm levels. In a “real-world” fire, the smoke would continue to be produced as the fire grows, permitting the detector to reach alarm. If these features are disabled during the testing, they should be enabled at the conclusion of the testing before leaving the room.

**B.3.3.2 Test Locations.** Test locations should be selected by considering the airflow patterns in the room and choosing challenging locations for the tests (i.e., both low airflow and high airflow can be challenging). If possible, the locations and elevations of the test apparatus should be varied to simulate the range of possible fire locations in the room. Locations where the smoke will be drawn directly into the telecommunications equipment cooling ports or fans should be avoided. Locations where the smoke will be entrained into the air exhausting from an equipment cabinet are acceptable.

**B.3.3.3 Preparation.** The required mass of lactose and potassium chlorate should be weighed into a mixing container, and mixed well by shaking or stirring to break up all lumps or clumps. The mixing container should be sealed tightly until ready to conduct the test.

**B.3.3.4 Placement.** The crucible should be placed on the support in the test location.

**Table B.2.3.7 Heated Wire Test Electrical Specifications**

Test	Voltage Setting	Current Setting	Current Application Time
2 m BSI wire test	6.0 volts dc	0 to 15 amperes (varies)	180 seconds
1 m BSI wire test	6.0 volts dc	0 to 15 amperes (varies)	60 seconds
Two BSI 6266 wires in parallel	6.0 volts dc	Current varies from 0 to 30 amperes during the test due to changing resistance in the wire	60 seconds
One North American wire	Voltage varies from 0 to 18 volts dc during the test due to changing resistance in the wire	0.28 ampere	30 seconds

**B.3.3.5 Test.** When all other test preparations are complete, the required amount of mixture should be poured into the crucible, keeping it in a compact mound (without packing it down). The mixture should be ignited with the long-handled butane lighter.

This mixture is essentially the formula for a match head. When ignited, it burns vigorously like a match (and smells the same). Be sure to use a long lighter to avoid being burned when the mixture ignites.

**B.3.4 Test Sequence.** The test should be repeated at least three times for each HVAC condition, with the test apparatus placed in a different location in the room each time. If possible, the elevation of the test apparatus should be varied.

**B.3.5 Pass/Fail Criteria.** The EWFD system should produce an “alert” or “pre-alarm” signal within 120 seconds of the cessation of ignition.

### Annex C Hazard Areas and Other Issues of Concern

*This annex is not a part of the requirements of this NFPA document but is included for informational purposes only.*

**C.1** The hazard areas or issues that should be known when visiting a telecommunications facility are covered in C.1.1 through C.1.22.

**C.1.1 Familiarizing with Hazard Areas.** When visiting a telecommunications facility to determine the conditions or familiarize oneself with the nature of telecommunications hazard areas, it is wise to be aware of characteristics of the areas and hazards or issues that can be associated with them.

**C.1.2 Standby Engine Area.** Standby power generators are located within these areas and are used as a power source during commercial power failures. The generators are driven by engines and or turbines that are fueled using a variety of fuels including diesel, propane, natural gas, or #2 fuel oil. Fire hazards associated with liquid and gaseous fuels should be considered. Electrical hazards should also be considered, including the power generated and the starting circuit for the engine. Technicians should wear hearing protection while the engine is running. They might not hear audible fire alarm signals while the engine is running or when they are wearing hearing protection.

**C.1.3 Main Distribution Frame (MDF) Area.** The wiring associated with distribution frames could be combustible due to the type of wire insulation used in the past and the large surface area created by the separation of wires. The wires forming the individual telecommunications circuits are usually protected against externally induced over-voltage conditions at the main distribution frame. Cables typically enter the frame area from a cable entrance facility area below through a floor or wall. Sealing of cable penetrations and ongoing maintenance of the seals are necessary for integrity of the MDF area floor fire separation.

**C.1.4 Cable Entrance Facility Area.** An unventilated cable entrance facility area could have natural gas or methane gas accumulations having explosion potential if not properly ventilated. There is also the possibility of flammable liquids leaking into the cable entrance facility area from external fuel spills. Cable entering from outside the telecommunications facility could be combustible. Cables entering the cable entrance facility area often have metallic sheaths grounded within the

vault to protect against accidental exposure of the sheath to external current sources.

**C.1.5 Power Areas.** Alternating current (ac) power is converted to direct current (dc) power by rectifiers and is stored in batteries to power the telecommunications equipment. The batteries provide power during commercial ac power failures. The batteries can be expected to provide power to the signal-processing equipment for several hours. Visitors should act as if the batteries are fully charged at all times. This should be a consideration even when working in or around a “depowered” power area. Direct current bus bars are often not insulated, presenting a danger to personnel using metal tools or wearing metallic jewelry or watches in proximity to the bus bars. Hydrogen gas could be present and should be vented to prevent the buildup to explosive levels. Many types of batteries contain dilute sulfuric acid-based electrolyte.

Hydrogen gas can be produced during battery use for both flooded cell and valve regulated lead acid (VRLA) batteries. Battery areas require proper ventilation. VRLA batteries minimize acid spill potential, because the electrolyte is immobilized. The VRLA batteries do have the potential for thermal runaway. VRLA batteries need to be maintained in a properly conditioned environment and should be monitored for signs of thermal runaway, increases in charging voltage, charging current, or battery temperature, so that proper action can be taken.

**C.1.5.1** Alternative energy systems (photovoltaic, fuel cell, wind turbine, microturbine and others) typically are dc output systems that convert to ac through the use of inverters or other power conversion process. All such systems should meet the applicable codes and standards. (See also A.6.10.9.1.)

**C.1.6 Uninterruptible Power Systems (UPS).** UPS could be present in various areas to power certain ac-powered telecommunications equipment. These are not generally considered to be power areas unless they are large and, therefore, similar to power areas.

**C.1.7 Signal-Processing Equipment Areas.** Signal-processing equipment provides paths and switching for data, voice, video, broadband signals, packets, and streams. Circuit boards and wiring insulation are combustible, but much of the telecommunications equipment and cables in use in North America are designed and manufactured with fire-resistant components and treatments. Many of the requirements of this standard anticipate that the signal-processing equipment, wire, and cable in use has fire resistance characteristics and ratings. The signal-processing equipment could contain both ac and dc power circuits from more than one source. The signal-processing equipment is very sensitive to products of combustion, including acid gases and soot, and can be sensitive to rapid changes in conditions, including ambient temperature and humidity.

**C.1.8 Security Requirements.** Access to the telecommunications facility as well as to vital areas within the facility should be controlled and limited.

**C.1.9 Environmental Equipment Concerns.** Telecommunications equipment requires a controlled environment to operate properly. Abrupt changes to the environment should be avoided.

**C.1.10 Multiple Power Sources.** Expect voltages of 120, 208, 240, and possibly 600 volts ac. The dc power most commonly used is 48 volts, 24 volts, and even lower for some circuits;

however, newer dc systems with nominal voltages of 380 and 575 volts are being deployed.

**C.1.11 External Exposures.** Telecommunications equipment should not be exposed to explosion, dust, electromagnetic fields, and high-intensity radio frequency signals and should not be located adjacent to high hazard occupancies.

**C.1.12 Effects of Water.** Water on energized telecommunications equipment could cause permanent damage.

**C.1.13 Building Support Equipment.** When building support equipment is installed on floors over telecommunications equipment areas, there is the potential for liquid releases from any source (e.g., plumbing systems, water piping) to penetrate through openings in the floor and damage telecommunications equipment below. Floors should be sealed to prevent the entry of liquids. Building support equipment should not be installed over signal-processing equipment, main distribution frames, power areas, generator rooms, or cable entrance areas.

**C.1.14 Nonthermal Threat.** Smoke from all types of fires, in any combustible materials, poses a significant hazard to electronic telecommunications equipment and should be minimized or exhausted.

**C.1.15 Limited Combustibility.** Limited combustibility has typically been used for telecommunications facility construction. Much of the telecommunications equipment and cable contents could exceed the potential heat value given in NFPA 220 of 8141 kJ/kg (3500 Btu/lb) when tested in accordance with NFPA 259. The committee has cited acceptable industry standards that have been used by telecommunications service providers to limit the fire loading, flame spread, and heat release rates of combustibles in telecommunications facilities.

**C.1.16 Removing Power from Telecommunications Equipment.** Familiarization with the proper procedures to shut down power to telecommunications equipment should be done in concert with the telecommunications personnel who are responsible for the facility.

**C.1.17 Compartmentation.** Separation of sensitive electronic telecommunications equipment from other hazard areas, such as administrative office and storage areas, is important.

**C.1.18 Installation Precautions.** During installation of fire protection systems, protection against dust and falling objects on telecommunications equipment should be considered. Contact with exposed conductors and battery terminals should be prevented.

**C.1.19 Alternating Current and Direct Current Power Panels and Lines.** Care should be taken not to touch any electrical connections or exposed conductors to prevent electric shock hazards.

**C.1.20 Static Electricity.** Some signal-processing equipment is extremely sensitive to static electricity discharge. People entering telecommunications equipment areas should take care to avoid static discharge on equipment.

**C.1.21 Combustible Packaging Material.** Excess packaging material should be limited to a few days' supply. Typically, boxed new electronic telecommunications equipment is brought in and staged in preparation for change out of older electronic equipment. (See Chapter 9 for guidance.)

**▲ C.1.22 People.** Telecommunications equipment areas in most facilities have a very low density of people. However, in some larger facilities, a growing number of administrative office areas can contain people in densities that are more typical of commercial office buildings.

#### Annex D Smoke Management

*This annex is not a part of the requirements of this NFPA document but is included for informational purposes only.*

**D.1** The following information is adapted from "Network Reliability: A Report to the Nation," Federal Communications Commission's Network Reliability Council.

Although smoke management is applicable to all areas of a building, it is most important in the signal-processing equipment areas, main distribution frame areas, and power areas. It is estimated that 95 percent of the fire damage in telephone central offices is attributed to the smoke products and only 5 percent is caused by the thermal effect of fires. In any fire accident there is a quantity of combustion products generated before the complete suppression of the fire that can cause short- or long-term damage to sensitive telecommunications equipment. The objective of smoke management systems is the rapid confinement and elimination of the products of combustion. Therefore, the design parameters of smoke management systems are driven by telecommunications equipment vulnerability criteria and the respective smoke generation rate and transport patterns.

The hazards associated with materials involved in fires can be defined and quantified by the heat release rate during their combustion, the rate of generation of fire products (gases, liquids, and solids), and the total amount of heat and fire products generated. In addition it is necessary to know the amount of cooling air (forced and convection) passing through equipment that will enter the smoke layer. This fire source information is necessary input to smoke movement and transport models. Information about the heat release rates and smoke yields of materials and commodities is catalogued, and methods for obtaining these values have been reported in the *SFPE Handbook of Fire Protection Engineering*. Pyrolysis and combustion models that simulate fire spread and growth have also been developed. They could be used in combination with computer models that predict the smoke movement (e.g., models for smoke detection and models predicting the descent of smoke from the ceiling to the floor, or the transport of smoke to adjacent areas). The cumulative quantity of the collected smoke, and the rate of deposition on the surfaces exposed to the combustion products as a function of time and source intensity, is used to assess the damage inflicted on sensitive telecommunications equipment.

Research and field experience have suggested a casual relationship between zinc chloride accumulation on electronic components and telecommunications equipment damage. The success of post-fire recovery and restoration of equipment exposed to smoke containing halogenated gases was found to depend strongly on the amount of zinc chloride accumulated on equipment surfaces. For electronic signal-processing equipment, levels of 30 to 60  $\mu\text{g}/\text{in.}^2$  were observed to accumulate over greater than 20 years of normal environmental exposure and pose no special problem. Signal-processing equipment exposed to fire gases and attaining accumulations of below 200  $\mu\text{g}/\text{in.}^2$  were easily restorable with little loss of reliability. Accu-

mulation levels up to 600  $\mu\text{g}/\text{in.}^2$  were restorable as long as strict environmental controls were implemented soon after the fire. The cost of restoration of telecommunications equipment with accumulations above 600  $\mu\text{g}/\text{in.}^2$  approached the cost of the telecommunications equipment itself, with no guarantee of long-term reliability.

The goal of any smoke management solution in a telecommunications facility is the mitigation of possible service interruption consequences by reducing smoke damage to acceptable levels. The following steps are necessary to evaluate the potential damage caused by a fire and to establish quantitative criteria and objectives for any engineered solution averting smoke damage:

- (1) Determination of detection time
- (2) Determination of smoke control system activation
- (3) Determination of the distribution of smoke spatial concentration
- (4) Calculation of deposition rate of smoke products on vulnerable surfaces
- (5) Calculation of total deposition of smoke products from fire initiation until final smoke control

Currently available tools and methods provide the vehicle for the computation of these five parameters.

The next step is the selection of the most appropriate and feasible smoke management strategy that minimizes the total smoke deposition and reflects the realistic conditions of the facility.

The most appropriate considerations for telecommunications facilities are as follows:

- (1) Compartmentation
- (2) Early and reliable detection of smoke from flaming and nonflaming fires
- (3) Automatic and reliable activation of smoke removal systems at the early stages of the fire (small flame size)
- (4) Measures limiting migration of smoke into connecting areas in combination with passive smoke barriers, opposing airflow, and pressurization of surrounding area

The most attractive smoke strategy for existing facilities that are not scheduled for any other retrofit is the early smoke detection with automatic activation of smoke exhaust system. For systems that will undergo planned equipment changes, compartmentation combined with early detection and automatic exhaust system actuation could be a desirable and feasible smoke control strategy. For new facilities (new designs) — in particular multistory, multioccupant buildings — compartmentalization on passive or active and automatic pressurization of adjacent areas connected with the room of the fire origin would be a recommended strategy.

## Annex E Pre-Fire Planning

*This annex is not a part of the requirements of this NFPA document but is included for informational purposes only.*

**E.1** Pre-fire planning for telecommunications facilities covered by this standard is an essential component for life safety considerations of its occupants and for the fire fighters providing protection for the facility. Telecommunications facilities vary both in size and complexity of operation. Further, the critical nature of the communications service provided by the facility might not be reflected by the variables of size and

complexity of operation. In any event, achieving the objective of this section, pre-fire plans would be expected to vary significantly in details from those for a small facility and those for a large facility, as described within this standard. The plan can incorporate actions, including investigation, evaluation and mitigation of the incident, fire suppression activities, and evacuation/relocation guidelines and assignments.

A fundamental concept of effective fire protection of a telecommunications facility is the recognition that there should be a good relationship or interaction or both between the telecommunications industry provider and the emergency services provider (normally the local fire department).

Telecommunications facilities are unique occupancies that normally provide vital links for the community for emergency services through 911-type communications links and other vital government-type circuits in addition to routine communication services expected of their customers.

It is recognized that sensitivity to this and other unique services provided to the community by the facility are brought to the awareness level of the emergency services provider through pre-fire planning. Pre-fire planning for the facility by the fire officials along with the necessary interface with representatives of the facility can ensure that objectives during actual fire emergencies are accomplished effectively and efficiently with as little interruption to the service as possible.

It is recognized that as the magnitude of a fire within a facility increases, issues of depowering parts of the facility become critical to controlling the fire and minimizing life safety exposure to fire suppression officers.

Decisions regarding depowering a facility should be carefully weighed, having been considered during pre-fire planning and given full consideration to the loss of the vital community communication links. When it is deemed necessary to depower a facility or part of a facility, the pre-fire planning done for the facility will help ensure the safe and efficient accomplishment of this objective with the minimum amount of service interruption for the facility as is possible.

The pre-fire plan can also include the following:

- (1) Location of all pre-fire plan documents.
- (2) Location of facility's alarm panel.
- (3) Completed building fact sheet including a list of emergency contacts.
- (4) Specific responsibilities assigned to designated personnel, including the use of a guard service (where provided). The telecommunications management should ensure that guards are knowledgeable of fire emergency systems in the facility and the pre-fire plan.
- (5) Depowering procedures to enable continuity of service in a fire situation by identifying the locations of electrical depowering devices. This procedure should include the following:
  - (a) Coded floor prints located in the pre-fire plan document and facility signage to direct fire personnel to depowering locations
  - (b) The method of turning off power to the following:
    - i. Alternating current power board. This is the primary source of electric power for a telecommunications facility and is supplied by the local power company.

- ii. Standby power generator. This unit, usually a turbine or diesel generator, provides standby ac power that is transferred manually or automatically whenever a loss of ac power is experienced.
- iii. Direct current primary disconnect fuse or circuit breaker bay. This unit distributes dc power to the secondary fuse or circuit breaker panels throughout the central office. The secondary fuse or circuit breaker panels feed all the operating voltages to the central office branch circuits.
- iv. Uninterruptible power supply (UPS)
- v. HVAC systems serving the area
- vi. Alternative energy devices, such as wind turbines, fuel cells, photovoltaic systems, or other devices providing power to the facility

### Annex F Assumptions Related to Specific Hazard Areas

*This annex is not a part of the requirements of this NFPA document but is included for informational purposes only.*

**F.1** Sections F.2 through F.9 address typical areas in telecommunications facilities and provide information that should be considered in the development of assumptions. Additional considerations can be required for specific scenarios or design situations.

**F.2 Telecommunications Equipment Areas.** Telecommunications equipment areas extending to fire safe compartmentation (either fire-rated walls or exterior walls of the facility in small facilities) could contain associated signal processing, power, main distribution frame, communications cables, and related support equipment. Telecommunications equipment areas, if occupied, are normally occupied only by employees directly supporting the equipment. The occupants are assumed to be trained, alert, and capable of self-rescue. The occupant load is assumed to be low from an egress standpoint. These areas have a low probability of fire ignition and sustainability because of the limited quantity of combustible products. If a fire does start, the items in the area that could burn include cables that when burning will produce highly corrosive products of combustion.

**F.3 Signal-Processing Equipment Areas.** A signal-processing equipment area is an area in which the signal-processing equipment is located. Signal-processing equipment areas, if occupied, are normally occupied only by employees directly supporting the equipment. The occupants are assumed to be trained, alert, and capable of self-rescue. The occupant load is assumed to be low from an egress standpoint. These areas have a low probability of fire ignition and sustainability because of the limited quantity of combustible products. If a fire does start, the items in the area that could burn include cables that when burning will produce highly corrosive products of combustion.

**F.4 Cable Entrance Facilities.** A cable entrance facility is the interface point between the outside plant cabling and the telecommunications equipment. These areas are normally unoccupied. Where these areas are occupied during cable alterations, it is assumed that the occupants within these areas are trained, alert, and capable of self-rescue. The occupant load is assumed to be low from an egress standpoint. These areas have the potential for accumulating combustible gases and liquids, such

as methane, that enter the facility through underground cable openings.

Fires within cable entrance facilities, whether of high or low heat release rate, are a concern due to the corrosivity of the products of combustion. Combustion products generally contain acid gases and solid particulates. Effects on the reliability of electronic equipment range from degradation of performance and reduction in the expected service life to complete failure of the telecommunications equipment. Recovery methods such as reduced levels of relative humidity within the space and cleaning of the equipment have shown to minimize the detrimental effects of exposure to combustion products.

**F.5 Power Areas.** These areas typically include the batteries, rectifiers, inverters, and related bus bars and cables. It is assumed that the thermal effects of a fire in the power equipment will be contained within the equipment. Fires in battery casings and cables are a concern due to the corrosivity of the smoke that is generated. Occupants are assumed to be trained, alert, and capable of self-rescue. The occupant load is relatively low from an egress standpoint. The fire loading of the area is low. Batteries can generate hydrogen during charging that could be an explosion hazard. It is assumed that the possibility of thermal runaway has been mitigated through battery management. Additionally, it is assumed that the hydrogen explosion hazard will be mitigated and localized by adequate ventilation of the area.

**F.6 Main Distribution Frame.** The main distribution frame is a wiring frame through which customers' phone lines are physically connected to signal-processing equipment or where cable connections between signal-processing equipment are made. Replacement of a frame damaged as a result of a fire is extremely labor intensive. Occupants in this area are assumed to be trained, alert, and capable of self-rescue. The occupant load is relatively low from an egress standpoint. This area typically includes large amounts of low voltage communication wire.

Fires within main distribution frame areas, whether of high or low heat release rate, are a concern due to the corrosivity of the products of combustion. Combustion products generally contain acid gases and solid particulates. Effects on the reliability of telecommunications equipment range from degradation of performance and reduction in the expected service life to complete failure of the equipment. Recovery methods such as reduced levels of relative humidity within the area and cleaning of the telecommunications have been shown to minimize the detrimental effects of exposure to combustion products.

**F.7 Standby Engine Areas.** These areas typically include internal combustion engines, generators, combustible liquids (day tank) or flammable gas, and starting batteries. It is assumed that a fire in the area is a Class B fire or a Class C fire. Occupants are trained, alert, and capable of self-rescue. The occupant load is low from an egress standpoint. Although it could be expected that a fire in this area could be a Class B liquid fuel fire, recent history has shown that fires in these areas have been Class C electrical in nature.

**F.8 Technical Support Areas and Ancillary Areas.** The technical support and vendor staging areas that directly support telecommunications equipment are a part of the telecommunications areas. The occupant load is low from an egress standpoint. The typical work location consists of metal

furniture with a personal computer workstation. Some amounts of file storage and catalog library are expected.

**F.9 Administrative Areas.** These areas typically include offices (e.g., administrative, accounting, engineering), mail rooms, cafeterias, and customer service operation center types of working environments. The fire loading of these areas varies from low for customer service center to medium for accounting and engineering offices. The occupant load is medium from an egress standpoint.

**F.10 Building Services and Support Areas.** These areas typically include utility areas, mechanical equipment areas, the various maintenance shops, loading docks, and associated storage areas. The fire loading of these areas varies from medium for maintenance shops to high for storage areas. It is assumed that combustibles will be in accordance with 9.1.1. Characteristics requiring assumptions include occupant abilities and locations, and the nature of the thermal and nonthermal threats expected in telecommunications facilities (e.g., fuel loading and heat release rate of materials, extent of fire spread, amount and nature of smoke generated). The fuel loading and potential heat release rate of fires are dependent on the materials and equipment that are employed.

## Annex G Informational References

**G.1 Referenced Publications.** The documents or portions thereof listed in this annex are referenced within the informational sections of this standard and are not part of the requirements of this document unless also listed in Chapter 2 for other reasons.

**▲ G.1.1 NFPA Publications.** National Fire Protection Association, 1 Batterymarch Park, Quincy, MA 02169-7471.

NFPA 1, *Fire Code*, 2018 edition.

NFPA 12A, *Standard on Halon 1301 Fire Extinguishing Systems*, 2018 edition.

NFPA 13, *Standard for the Installation of Sprinkler Systems*, 2019 edition.

NFPA 25, *Standard for the Inspection, Testing, and Maintenance of Water-Based Fire Protection Systems*, 2020 edition.

NFPA 30, *Flammable and Combustible Liquids Code*, 2018 edition.

NFPA 68, *Standard on Explosion Protection by Deflagration Venting*, 2018 edition.

NFPA 70®, *National Electrical Code®*, 2020 edition.

NFPA 72®, *National Fire Alarm and Signaling Code®*, 2019 edition.

NFPA 75, *Standard for the Fire Protection of Information Technology Equipment*, 2020 edition.

NFPA 80A, *Recommended Practice for Protection of Buildings from Exterior Fire Exposures*, 2017 edition.

NFPA 92, *Standard for Smoke Control Systems*, 2018 edition.

NFPA 101®, *Life Safety Code®*, 2018 edition.

NFPA 204, *Standard for Smoke and Heat Venting*, 2018 edition.

NFPA 220, *Standard on Types of Building Construction*, 2018 edition.

NFPA 241, *Standard for Safeguarding Construction, Alteration, and Demolition Operations*, 2019 edition.

NFPA 259, *Standard Test Method for Potential Heat of Building Materials*, 2018 edition.

NFPA 853, *Standard for the Installation of Stationary Fuel Cell Power Systems*, 2020 edition.

NFPA 2001, *Standard on Clean Agent Fire Extinguishing Systems*, 2018 edition.

NFPA 5000®, *Building Construction and Safety Code®*, 2018 edition.

*Fire Protection Handbook*, 20th edition.

FPFR, “Validation of Modeling Tools for Detection Design in High Air Flow Environments,” 2012.

FPFR, “Validation of Modeling Tools for Detection Design in High Air Flow Environments — Phase II,” 2014.

**▲ G.1.2 Other Publications.**

**▲ G.1.2.1 ASHRAE Publications.** ASHRAE, 1791 Tullie Circle, NE, Atlanta, GA 30329-2305.

ASHRAE 52.2, *Method of Testing General Ventilation Air-Cleaning Devices for Removal Efficiency by Particle Size*, 2017.

ASHRAE 149, *Laboratory Methods of Testing Fans Used to Exhaust Smoke in Smoke Management Systems*, 2013.

Klote, J. H., and J. A. Milke, *Principles of Smoke Management*, 2002.

**G.1.2.2 ASTM Publications.** ASTM International, 100 Barr Harbor Drive, P.O. Box C700, West Conshohocken, PA 19428-2959.

ASTM E648, *Standard Test Method for Critical Radiant Flux of Floor-Covering Systems Using a Radiant Heat Energy Source*, 2017a.

**G.1.2.3 BSI Publications.** BSI Group, 12950 Worldgate Drive, Suite 800, Herndon, VA 20170

BS 6266, *Fire Protection for Electronic Data Processing Installations*, 2011.

**▲ G.1.2.4 CGA Publications.** Compressed Gas Association, 14501 George Carter Way, Suite 103, Chantilly, VA 20151.

CGA P-1, *Safe Handling of Compressed Gases in Containers*, 2015.

**G.1.2.5 FM Publications.** FM Global, 270 Central Avenue, P.O. Box 7500, Johnston, RI 02919.

Thumuluru, S., B. Ditch, P. Chatterjee, and M. Chaos, “Experimental Data for Model Validation of Smoke Transport in Data Centers,” 2014.

**G.1.2.6 FM Approvals Publications.** FM Approvals LLC, 1151 Boston-Providence Turnpike, P.O. Box 9102, Norwood, MA 02062.

FM Approvals Class Number 3972, *Test Standard for Cable Fire Propagation*, 2009.



**G.1.2.7 IEEE Publications.** IEEE, 3 Park Avenue, 17th Floor, New York, NY 10016-5997.

ANSI/IEEE 304, *Test Procedure for Evaluation and Classification of Insulation Systems for Direct-Current Machines*, 1977, reaffirmed 1991 (withdrawn 2004).

IEEE 1635/ASHRAE 21, *Guide for the Ventilation and Thermal Management of Batteries for Stationary Applications*, 2018.

**N G.1.2.8 SFPE Publications.** Society of Fire Protection Engineers, 9711 Washingtonian Blvd, Suite 380, Gaithersburg, MD 20878.

SFPE *Engineering Guide to Performance-Based Fire Protection*, 2nd edition.

SFPE *Guidelines for Peer Review in the Fire Protection Design Process*, 2009.

SFPE *Handbook of Fire Protection Engineering*, 5th edition.

**G.1.2.9 UL Publications.** Underwriters Laboratories Inc., 333 Pfingsten Road, Northbrook, IL 60062-2096.

ANSI/UL 555, *Standard for Fire Dampers*, 2006.

ANSI/UL 555S, *Standard for Smoke Dampers*, 2014.

UL 568, *Nonmetallic Cable Tray Systems*, 2002.

ANSI/UL 864, *Standard for Control Units and Accessories for Fire Alarm Systems*, 2014.

ANSI/UL 60950-1, *Information Technology Equipment — Safety — Part 1: General Requirements*, 2013.

UL Subject 2436, *Outline of Investigation for Spill Containment for Lead Acid Battery Systems*, 2006.

**G.1.2.10 U.S. Government Publications.** U.S. Government Publishing Office, 732 North Capitol Street, NW, Washington, DC 20401-0001.

Title 29, Code of Federal Regulations, Part 1910, “Telecommunications.”

Title 29, Code of Federal Regulations, Part 1910.34, “Coverage and Definitions.”

**G.1.2.11 Other Publications.**

Drysdale, D., *An Introduction to Fire Dynamics*, John Wiley & Sons, Chichester, England, 1998.

“Network Reliability: A Report to the Nation; Fire Prevention in Telecommunications Facilities,” Federal Communications Commission Network Reliability Council, 1993.

“Fire Extinguishment Testing of Sprinkler Protected Telecommunications Equipment,” Bell Northern Research, 1987.

Reagor, B. T., “Smoke Corrosivity: Generation, Impact, Detection and Protection Colloquium on Smoke Corrosivity,” *Journal of Fire Sciences*, Baltimore, MD, November 7–8, 1991.

“The Special Need for a Smoke Exhaust System to Minimize Secondary Damage to Electronic Telephone Switching Equipment,” H. H. Angus & Associates, 1992.

Tanaka, T. J., “Effects of Smoke on Functional Circuits,” NUREG/CR-6542 SAND97-2544.

Tanaka T. J., S. P. Nowlen, and D. J. Anderson, “Circuit Bridging of Components by Smoke,” NUREG/CR-6476 SAND96-2633.

Telcordia GR-63-CORE, (formerly Bellcore), *Network Equipment Building System (NEBS)™ Requirements: Physical Protection*, Issue 2, April 2002.

**G.2 Informational References.** The following documents or portions thereof are listed here as informational resources only. They are not a part of the requirements of this document.

**G.2.1 ASTM Publications.** ASTM International, 100 Barr Harbor Drive, P.O. Box C700, West Conshohocken, PA 19428-2959.

ASTM D2863, *Standard Test Method for Measuring the Minimum Oxygen Concentration to Support Candle-like Combustion of Plastics (Oxygen Index)*, 2017a.

ASTM E380, *Standard Practice for Use of the International System of Units (SI) (The Modernized Metric System)*, 1993.

ASTM E1354, *Standard Test Method for Heat and Visible Smoke Release Rates for Materials and Products Using an Oxygen Consumption Calorimeter*, 2013m (withdrawn 2017).

**Δ G.2.2 ATIS Publications.** Alliance for Telecommunications Industry Solutions, 1200 G Street NW, Suite 500, Washington, DC 20005.

ATIS 0600311, *DC Power Systems — Telecommunications Environment Protection*, 2007 (R2012).

ATIS 0600328, *Protection of Telecommunications Links from Physical Stress and Radiation Effects and Associated Requirements for DC Power Systems*, 2012.

**G.2.3 CSA Group Publications.** CSA Group, 178 Rexdale Boulevard, Toronto, ON M9W 1R3, Canada.

CSA C22.2, No. 0.3, *Test Methods for Electrical Wires and Cables*, 2009, revised 2014.

**G.2.4 DOE Publications.** U.S. Department of Energy, 1000 Independence Avenue, SW, Washington, DC 20585.

DOE/EP-0108, *Standard for Fire Protection of DOE Electronic Computer/Data Processing Systems, Annex B, Reconditioning of Flooded and Smoke-Contaminated Equipment*, 1986.

**G.2.5 IEEE Publications.** IEEE, 3 Park Avenue, 17th Floor, New York, NY 10016-5997.

ANSI/IEEE 383, *Standard for Qualifying Class IE Electric Cables and Field Splices for Nuclear Power Generating Stations*, 2015.

ANSI/IEEE 1202, *Standard for Flame-Propagation Testing of Wire and Cable*, 2006/Cor 1-2012.

**G.2.6 NFPA Publications.** National Fire Protection Association, 1 Batterymarch Park, Quincy, MA 02169-7471.

NFPA 262, *Standard Method of Test for Flame Travel and Smoke of Wires and Cables for Use in Air-Handling Spaces*, 2019.

**G.2.7 UL Publications.** UL LLC, 333 Pfingsten Road, Northbrook, IL 60062-2096.

ANSI/UL 263, *Standard for Fire Tests of Building Construction and Materials*, 2011.

UL 510, *Standard for Safety Polyvinyl Chloride, Polyethylene and Rubber Insulating Tape*, 2017.

ANSI/UL 1441, *Coated Electrical Slewing*, 2005.

ANSI/UL 1479, *Standard for Fire Tests of Through-Penetration Firestops*, 2015.

ANSI/UL 1581, *Reference Standard for Electrical Wires, Cables, and Flexible Cords*, 2001.

ANSI/UL 1666, *Standard for Test for Flame Propagation Height of Electrical and Optical-Fiber Cables Installed Vertically in Shafts*, 2007.

ANSI/UL 1685, *Standard for Vertical-Tray Fire-Propagation and Smoke-Release Test for Electrical and Optical-Fiber Cables*, 2007.

ANSI/UL 1784, *Air Leakage Tests of Door Assemblies*, 2015.

#### **G.2.8 Other Publications.**

ASHRAE *Handbook — Fundamentals*, 2013.

IEC 60695-4, *Fire Hazard Testing — Part 4: Terminology concerning fire tests for electromechanical products*, 2012.

IEC 60695-11-5, *Fire Hazard Testing — Part 11-5: Test flames - Needle-flame test method - Apparatus, confirmatory test arrangement and guidance*, 2014.

ISO 9705, *Fire Test — Full Scale Room Test for Surface Products*, 1993.

Klote, J.H., J.A. Milke, P.G. Turnbull, A. Kashef, and M.J. Ferreira, *Handbook of Smoke Control Engineering*, 2012.

National Bureau of Standards Handbook 91, *Experimental Statistics*, Mary Gibbons Natrella, August 1963.

T1E1.8/95-032, *Telecommunications Central Office Equipment Fire Research Report*, May 1992.

#### **G.3 References for Extracts in Informational Sections. (Reserved)**

## Index

Copyright © 2019 National Fire Protection Association. All Rights Reserved.

The copyright in this index is separate and distinct from the copyright in the document that it indexes. The licensing provisions set forth for the document are not applicable to this index. This index may not be reproduced in whole or in part by any means without the express written permission of NFPA.

### -A-

#### **Abandoned Cables**

Definition, 3.3.1

#### **Administration, Chap. 1**

Application, 1.3, A.1.3

Design Options, 1.5, A.1.5

Equivalency, 1.6

Purpose, 1.2, A.1.2

Retroactivity, 1.4

Scope, 1.1, A.1.1

#### **Administrative Areas**

Definition, 3.4.1

#### **Aisle**

Definition, 3.8.1, A.3.8.1

#### **Aisle Containment**

Definition, 3.8.2, A.3.8.2

#### **Analysis**

Definition, 3.7.1

Sensitivity Analysis

Definition, 3.7.1.1

Uncertainty Analysis

Definition, 3.7.1.2

#### **Approved**

Definition, 3.2.1, A.3.2.1

#### **Assumptions Related to Specific Hazard Areas, Annex F**

Administrative Areas, F.9

Building Services and Support Areas, F.10

Cable Entrance Facilities, F.4

Main Distribution Frame, F.6

Power Areas, F.5

Signal-Processing Equipment Areas, F.3

Standby Engine Areas, F.7

Technical Support Areas and Ancillary Areas, F.8

Telecommunications Equipment Areas, F.2

#### **Authority Having Jurisdiction (AHJ)**

Definition, 3.2.2, A.3.2.2

### -B-

#### **Battery**

Definition, 3.3.2

Lithium-Ion Battery

Definition, 3.3.2.1

Nickel Cadmium (NiCd) Battery

Definition, 3.3.2.2

Sodium-Nickel Battery

Definition, 3.3.2.3

Valve-Regulated Lead Acid (VRLA)

Definition, 3.3.2.4, A.3.3.2.4

Vented (Flooded)

Definition, 3.3.2.5, A.3.3.2.5

#### **Building Automation System**

Definition, 3.3.3

#### **Building Services and Support Areas**

Definition, 3.4.2

#### **Building Services Equipment**

Definition, 3.6.1

### -C-

#### **Cable Entrance Facility (CEF) Area**

Definition, 3.4.3

#### **Cable Entrance Facility (CEF) Equipment**

Definition, 3.6.2, A.3.6.2

#### **Cable Routing Assembly**

Definition, 3.3.4

#### **Cable Telecommunications**

Definition, 3.3.5

#### **Cable Vault**

Definition, 3.4.4

#### **Central Office (CO)**

Definition, 3.3.6

#### **Co-Located Telecommunications Equipment**

Definition, 3.6.3

#### **Cold Aisle**

Definition, 3.8.3, A.3.8.3

#### **Communications Raceway**

Definition, 3.3.7

#### **Contractor**

Definition, 3.3.8

#### **Controlled Environmental Vault (CEV)**

Definition, 3.3.9

### -D-

#### **Definitions, Chap. 3**

### -E-

#### **Early Warning Fire Detection (EWFD) Systems**

Definition, 3.5.1

#### **Explanatory Material, Annex A**

#### **Exposure Fire**

Definition, 3.7.2, A.3.7.2

### -F-

#### **Fire Model**

Definition, 3.7.3, A.3.7.3

#### **Fire Prevention, Chap. 9**

Cable Management, 9.8, A.9.8

Construction, Alterations, and Equipment Installations, 9.4, A.9.4

Building Construction and Alteration Work, 9.4.4, A.9.4.4

Bus Bar Protection During Construction Work, 9.4.5

- Cutting and Welding Activities, 9.4.2
  - Fire Prevention Awareness for Contractors, 9.4.6, A.9.4.6
  - Staging Areas, 9.4.1
  - Use and Storage of Combustible Materials, 9.4.3, A.9.4.3
  - Displays and Decorations, 9.7
  - Employee Awareness, 9.5
  - Housekeeping, 9.1, A.9.1
    - Clear Access, 9.1.8
    - Flammable and Combustible Liquids and Gases, 9.1.7, A.9.1.7
    - Heat-Producing Appliances, 9.1.4, A.9.1.4
    - Hot Work, 9.1.6, A.9.1.6
    - Limiting Other Combustibles, 9.1.2, A.9.1.2
    - Portable Heating Appliances, 9.1.3, A.9.1.3
    - Removal or Storage of Combustibles, 9.1.1, A.9.1.1
    - Smoking, 9.1.5, A.9.1.5
      - Designated Smoking Areas, 9.1.5.2, A.9.1.5.2
      - Signage, 9.1.5.3
      - Vaporizing E-Cigarettes, 9.1.5.1
  - Means of Egress, 9.6
  - Nontelecommunications Electrical Equipment and Wiring, 9.3
    - Electrical Cords, 9.3.2, A.9.3.2
  - Telecommunications Electrical Equipment and Wiring, 9.2, A.9.2
  - Fire Protection Elements**, Chap. 8
    - Alarm Processing, 8.4
      - General, 8.4.1
      - Signal Path Integrity, 8.4.3
      - Signaling, 8.4.2
        - Fire Alarm Signals, 8.4.2.1
        - Supervisory Signals, 8.4.2.2
        - Trouble Signals, 8.4.2.3
    - Compartmentation, 8.3, A.8.3
      - Fire-Resistance-Rated Construction, 8.3.1
      - Penetrations in Fire-Resistance-Rated Construction, 8.3.3
        - HVAC Systems, 8.3.3.2
        - Pipes, Conduits, Cables, and Cable Trays, 8.3.3.1
      - Protection of Fire-Resistance-Rated Construction Openings, 8.3.2
        - Construction Joints, 8.3.2.4
        - Doors, 8.3.2.1
          - Glazing Materials in Doors, 8.3.2.2
          - Glazing Materials in Fire-Resistance-Rated Construction, 8.3.2.3
    - Construction, 8.2
      - Aisle Containment Systems for Telecommunications Equipment, 8.2.3, A.8.2.3
      - Buildings, 8.2.1
      - Interior Walls, 8.2.2
    - Fire Detection, 8.5
      - Detection Systems, 8.5.2
        - General, 8.5.1
        - Installation, 8.5.3
          - EWFD, 8.5.3.2
            - Flame Detection Systems, 8.5.3.2.2
            - Smoke Detection Systems, 8.5.3.2.1
          - In-Cabinet Detection, 8.5.3.4
            - General, 8.5.3.4.1
      - SFD, 8.5.3.3
      - VEWFD, 8.5.3.1
        - VEWFD Spot-type Smoke Detector and Port Installation, 8.5.3.1.2
  - Fire-Extinguishing Systems, 8.6
    - Automatic Fire Suppression, 8.6.2
      - Clean Agents, 8.6.2.3
      - General, 8.6.2.1
      - Halon Systems, 8.6.2.4
      - In-Cabinet Suppression. (Reserved.), 8.6.2.6
      - Sprinkler Systems, 8.6.2.2
        - Water Mist Fire Protection Systems, 8.6.2.5
    - General, 8.6.1, A.8.6.1
    - Manual Fire Suppression, 8.6.3
      - Portable Fire Extinguishers, 8.6.3.1
        - Standpipes, 8.6.3.2, A.8.6.3.2
    - General, 8.1
  - Smoke Management Systems, 8.7
    - Design and Installation, 8.7.2, A.8.7.2
    - General, 8.7.1, A.8.7.1
    - Power Supply, 8.7.4
      - Loss of Power or Control Signal, 8.7.4.1
      - Manual Override, 8.7.4.2, A.8.7.4.2
    - Smoke Removal, 8.7.3, A.8.7.3
  - Telecommunications Equipment Ignition and Fire Performance, 8.8
    - General, 8.8.1, A.8.8.1
    - Major Telecommunications Equipment Systems, 8.8.3, A.8.8.3
    - Nonlabeled Wire, Cable, and Telecommunications Equipment, 8.8.4
    - Wire and Cables, 8.8.2
      - Installations Other Than Risers and Plenums, 8.8.2.10
      - Raised Floor and Ceiling Cavity Plenums, 8.8.2.8
      - Risers, 8.8.2.9
  - Fire Scenario**
    - Definition, 3.7.4, A.3.7.4
  - Firestop**
    - Definition, 3.3.10
  - Fuel Load**
    - Definition, 3.7.5
- H-**
- Hazard Area**
    - Definition, 3.4.5
  - Hazard Areas and Other Issues of Concern**, Annex C
  - Hot Air Collar**
    - Definition, 3.8.4, A.3.8.4
  - Hot Aisle**
    - Definition, 3.8.5, A.3.8.5
  - Hut**
    - Cell Hut
      - Definition, 3.3.11.1
    - Definition, 3.3.11
    - On-Grade Hut
      - Definition, 3.3.11.2

- I-**
  - Incapacitation**
    - Definition, 3.7.6
  - Informational References, Annex G**
  - L-**
  - Liquid Cooling**
    - Definition, 3.3.13
  - Listed**
    - Definition, 3.2.3, A.3.2.3
  - M-**
  - Main Distribution Frame (MDF) Area**
    - Definition, 3.4.6
  - Main Distribution Frame (MDF) Equipment**
    - Definition, 3.6.4, A.3.6.4
  - Maximum Allowable Quantity (MAQ)**
    - Definition, 3.3.12
  - N-**
  - Nontelecommunications Equipment Area**
    - Definition, 3.4.7
  - O-**
  - Occupant Characteristics**
    - Definition, 3.7.7
  - P-**
  - Performance Criteria**
    - Definition, 3.7.8, A.3.7.8
  - Performance Test Procedures for Very Early Warning and Early Warning Fire Detection Systems, Annex B**
    - Heated Wire Test, B.2
      - Test Apparatus, B.2.2
        - Power Supply and Leads, B.2.2.3
        - Stopwatch, B.2.2.4
          - Wire, B.2.2.1
            - Wire Mounting, B.2.2.2
      - Test Procedure, B.2.3
        - Connection, B.2.3.8
        - Detector Programming, B.2.3.2
        - Mounting, B.2.3.6
        - Pass/Fail Criteria, B.2.3.11
        - Positioning, B.2.3.4
        - Preparation, B.2.3.5
        - Setting, B.2.3.7
        - Test, B.2.3.9
        - Test Locations, B.2.3.3
        - Test Sequence, B.2.3.10
      - Introduction, B.1
        - Objectives, B.1.2
        - Scope, B.1.1
      - Lactose–Potassium Chlorate Test, B.3
        - Description, B.3.1
        - Pass/Fail Criteria, B.3.5
        - Procedure, B.3.3
          - Detector Programming, B.3.3.1
            - Placement, B.3.3.4
            - Preparation, B.3.3.3
            - Test, B.3.3.5
              - Test Locations, B.3.3.2
                - Test Apparatus, B.3.2
                  - Crucible or Open Cup, B.3.2.1
                    - Igniter, B.3.2.5
                    - Ignition Mixture, B.3.2.6
                    - Scale, B.3.2.3
                    - Stopwatch, B.3.2.4
                    - Support, B.3.2.2
                      - Test Sequence, B.3.4
- Performance-Based Approaches, Chap. 5**
  - Acceptance, 5.8
  - Design Assumptions, 5.4
    - Assumptions Regarding Emergency Response Personnel, 5.4.4
    - Assumptions Regarding Facility Characteristics, 5.4.2
    - Assumptions Regarding Off-Site Conditions, 5.4.5
    - Assumptions Regarding Operational Status and Effectiveness of Building Features and Systems, 5.4.3, A.5.4.3
    - Consistency of Assumptions, 5.4.6
    - General, 5.4.1
    - Specific Facility Hazard Areas Assumptions, 5.4.7
  - Documentation, 5.7
    - Building Design Specifications, 5.7.3
    - Fire Scenarios, 5.7.5
      - General, 5.7.1
      - Hazard Mitigation Specifications, 5.7.2
      - Input Data, 5.7.6
      - Output Data, 5.7.7
      - Prescriptive Elements, 5.7.9
      - Safety Factors, 5.7.8
      - Survivability Criteria, 5.7.4
  - Fire Scenarios, 5.5, A.5.5
    - Design Fire Scenarios, 5.5.2
      - Specified Scenarios, 5.5.2.1, A.5.5.2.1
        - Combustible Gas Fires, 5.5.2.1.6, A.5.5.2.1.6
          - Communications Cable or Power Cable Fires, 5.5.2.1.3, A.5.5.2.1.3
            - Electrical Component or Systems Fires, 5.5.2.1.2, A.5.5.2.1.2
              - Exterior Exposure Fires, 5.5.2.1.8, A.5.5.2.1.8
                - General, 5.5.2.1.1
                - Ignitable Liquid Fires, 5.5.2.1.5, A.5.5.2.1.5
                - Interior Exposure Fires, 5.5.2.1.7, A.5.5.2.1.7
                  - Nontelecommunications Equipment Fires, 5.5.2.1.4, A.5.5.2.1.4
        - Design Fires, 5.5.1
          - General, 5.1
            - Application, 5.1.1, A.5.1.1
            - Approved Qualifications, 5.1.2, A.5.1.2
            - Final Determination, 5.1.4
            - Independent Review, 5.1.3, A.5.1.3
            - Maintenance of Design Features, 5.1.5, A.5.1.5
            - Special Definitions, 5.1.6
          - Methods of Assessing Performance, 5.6
            - General, 5.6.1

- Methods for Verifying Performance, 5.6.6, A.5.6.6
- Output Data, 5.6.4
- Safety Factors, 5.6.3
- Use, 5.6.2
- Validity, 5.6.5
- Performance Criteria, 5.3
  - Life Safety Performance Criteria, 5.3.1, A.5.3.1
  - Network Performance Criteria, 5.3.2
- Performance Objectives, 5.2
  - Life Safety Objectives, 5.2.1
  - Network Objectives, 5.2.2
- Port**
  - Definition, 3.5.2
- Power Area**
  - Definition, 3.4.8
- Power Equipment**
  - Definition, 3.6.5
- Pre-Fire Planning**, Annex E
- Pre-Fire Planning, Damage Control, and Emergency Recovery**, Chap. 10
  - Fire Safety of Fire Fighters, 10.3, A.10.3
    - Fire Department Information, 10.3.1
    - Fire Service Orientation and Information, 10.3.2, A.10.3.2
  - General, 10.1
    - Elements, 10.1.2
    - Pre-Fire Plan, 10.1.1
  - Life Safety of Occupants of the Facility, 10.2, A.10.2
  - Selective Depowering, 10.4, A.10.4
- Prescriptive-Based Approaches**, Chap. 6
  - Administrative Areas, 6.14
    - Compartmentation, 6.14.3
    - Construction, 6.14.2
    - Cooking Areas, 6.14.5
    - Fire Protection, 6.14.4
      - Fire Detection, 6.14.4.1
        - Installation, Testing, and Maintenance, 6.14.4.1.2
      - Fire Suppression, 6.14.4.2
        - Automatic Fire Suppression, 6.14.4.2.2
        - Portable Fire Extinguishers, 6.14.4.2.1
    - General, 6.14.1
  - Building Service and Support Areas, 6.15
    - Compartmentation, 6.15.3
    - Construction, 6.15.2
    - Electrical, 6.15.6
    - Fire Protection, 6.15.4
      - Fire Detection, 6.15.4.1
        - Installation, Testing, and Maintenance, 6.15.4.1.2
      - Fire Suppression, 6.15.4.2
        - Automatic Fire Suppression, 6.15.4.2.2
        - Portable Fire Extinguishers, 6.15.4.2.1
    - General, 6.15.1
    - HVAC Systems, 6.15.5
    - Lightning and Surge Protection, 6.15.7
    - Special Hazards, 6.15.8
  - Building Services Equipment, 6.6
  - Cable Entrance Facility Area, 6.9
    - Building Services Equipment, 6.9.3
    - Cable Entrance Facility Equipment, 6.9.4, A.6.9.4
    - Compartmentation, 6.9.2
    - Fire Detection, 6.9.5
      - General, 6.9.5.1
        - Installation, Testing, and Maintenance, 6.9.5.2, A.6.9.5.2
    - Fire Suppression, 6.9.6
      - Automatic Fire Suppression, 6.9.6.2
      - Portable Fire Extinguishers, 6.9.6.1
        - General, 6.9.1, A.6.9.1
      - Limitation of Combustibles, 6.9.7
      - Smoke Management Systems, 6.9.9
      - Special Hazards, 6.9.8
  - Construction, 6.2
  - Emergency Lighting, 6.7
  - General, 6.1
    - Application, 6.1.1, A.6.1.1
    - Co-Located Telecommunications Equipment, 6.1.5
    - Determination of Signal-Processing Equipment Area, 6.1.3, A.6.1.3
    - Multiple Tenant Buildings, 6.1.4, A.6.1.4
    - Prescriptive Approach, 6.1.2, A.6.1.2
- Main Distribution Frame Areas, 6.11
  - Building Services Equipment, 6.11.4
  - Compartmentation, 6.11.3, A.6.11.3
  - Construction, 6.11.2
    - Floor/Ceiling Assemblies, 6.11.2.1
    - Raised Floors, 6.11.2.2
  - Fire Detection, 6.11.6
    - General, 6.11.6.2
    - General, 6.11.6.1
      - Installation, Testing, and Maintenance, 6.11.6.3
  - Fire Suppression, 6.11.7
    - Automatic Fire Suppression, 6.11.7.2
    - Portable Fire Extinguishers, 6.11.7.1
      - General, 6.11.1, A.6.11.1
    - Limitation of Combustibles, 6.11.8
  - Main Distribution Frame (MDF) Equipment, 6.11.5
  - Smoke Management Systems, 6.11.11
  - Special Hazards, 6.11.10
  - Technical Support Areas, 6.11.9
- Means for Selective Depowering, 6.5, A.6.5
- Means of Egress, 6.4, A.6.4
- Power Areas, 6.10
  - Batteries, 6.10.8
    - Additional Battery Technologies, 6.10.8.3
      - Battery Arrays, 6.10.8.3.3, A.6.10.8.3.3
      - Battery-Specific Protection, 6.10.8.3.9
        - Lithium-Ion Batteries, 6.10.8.3.9.1
        - Sodium-Nickel Batteries, 6.10.8.3.9.2
      - General, 6.10.8.3.1
      - Hazard Mitigation Analysis, 6.10.8.3.4
      - Installation, 6.10.8.3.6
        - Battery Chargers, 6.10.8.3.6.2
        - Battery Management System, 6.10.8.3.6.1
        - Mixed Battery Systems, 6.10.8.3.6.4, A.6.10.8.3.6.4
        - Signage, 6.10.8.3.6.3
      - Listings, 6.10.8.3.5

- Prepackaged and Pre-engineered Systems, 6.10.8.3.5.1, A.6.10.8.3.5.1
  - Maximum Allowable Quantities, 6.10.8.3.2
  - Suppression and Detection, 6.10.8.3.7
    - Fire Suppression, 6.10.8.3.7.1
    - Smoke Detection, 6.10.8.3.7.2
  - Testing, Maintenance, and Repairs, 6.10.8.3.10
  - Thermal Runaway, 6.10.8.3.8
  - General, 6.10.8.1
    - Environment, 6.10.8.1.2
      - Labels, 6.10.8.1.2.1
      - Signs, 6.10.8.1.2.2
    - Location and Occupancy Separation, 6.10.8.1.1
    - Seismic Protection, 6.10.8.1.3
  - Lead-Acid and Nickel-Cadmium Batteries, 6.10.8.2
    - General, 6.10.8.2.1
    - Neutralization, 6.10.8.2.5
    - Safety Venting, 6.10.8.2.2
      - Nonrecombinant Batteries, 6.10.8.2.2.1
      - Recombinant Batteries, 6.10.8.2.2.2
    - Signs, 6.10.8.2.7
    - Smoke Detection, 6.10.8.2.8
    - Spill Control, 6.10.8.2.4
    - Thermal Runaway, 6.10.8.2.3
    - Ventilation, 6.10.8.2.6, A.6.10.8.2.6
  - Other Battery Types, 6.10.8.4
  - Building Services Equipment, 6.10.3
  - Compartmentation, 6.10.2
  - Fire Detection, 6.10.5
    - General, 6.10.5.1
    - Installation, Testing, and Maintenance, 6.10.5.2
  - Fire Suppression, 6.10.6
    - Automatic Fire Suppression, 6.10.6.2
    - Portable Fire Extinguishers, 6.10.6.1
  - General, 6.10.1, A.6.10.1
  - Limitation of Combustibles, 6.10.7
  - Power Equipment, 6.10.4
  - Smoke Management Systems, 6.10.10
  - Special Hazards, 6.10.9, A.6.10.9
  - Protection from Exposures, 6.3, A.6.3
  - Signal-Processing Equipment Area, 6.8
    - Building Services Equipment, 6.8.4
    - Compartmentation, 6.8.3, A.6.8.3
    - Construction, 6.8.2
      - Floor/Ceiling Assemblies, 6.8.2.1
      - Raised Floors, 6.8.2.2
    - Fire Detection, 6.8.6
      - General, 6.8.6.2
      - General, 6.8.6.1
      - Installation, Testing, and Maintenance, 6.8.6.3
    - Fire Suppression, 6.8.7
      - Automatic Fire Suppression, 6.8.7.2
      - Portable Fire Extinguishers, 6.8.7.1
  - General, 6.8.1, A.6.8.1
  - Leak Detection for Liquid-Cooled Equipment, 6.8.8
  - Limitation of Combustibles, 6.8.9
  - Signal-Processing Equipment, 6.8.5
  - Smoke Management Systems, 6.8.11
  - Special Hazards, 6.8.10
  - Standby Engine Areas, 6.12
    - Building Services Equipment, 6.12.5, A.6.12.5
    - Compartmentation, 6.12.3
    - Construction, 6.12.2
    - Fire Detection, 6.12.7
      - General, 6.12.7.1
      - Installation, Testing, and Maintenance, 6.12.7.2
    - Fire Suppression, 6.12.8
      - Automatic Fire Suppression, 6.12.8.2
      - Portable Fire Extinguishers, 6.12.8.1
    - Fuel Control, 6.12.4, A.6.12.4
      - General, 6.12.1
    - Limitation of Combustibles, 6.12.9
    - Smoke Management Systems, 6.12.10
    - Standby Engine Installation, 6.12.6
  - Technical Support Areas, 6.13
    - Fire Protection Measures, 6.13.2
      - General, 6.13.1
- Proposed Design**
- Definition, 3.7.9
- R-**
- Redundant or Replacement-Based Approaches, Chap. 7**
- Building Services Equipment, 7.7
  - Construction, 7.2
  - Emergency Lighting, 7.8
  - Means for Depowering, 7.5
    - General, 7.5.1
  - Means of Egress, 7.4
  - Protection from Exposures, 7.3, A.7.3
  - Redundancy or Replacement Approach, 7.1, A.7.1
    - Application, 7.1.1
      - Redundancy Off Site, 7.1.1.2
      - Redundancy On Site, 7.1.1.1
      - Replacement, 7.1.1.3
    - Maintenance of Redundant or Replacement-Based Approach, 7.1.2
  - Telecommunications Equipment Areas, 7.6
    - Compartmentation, 7.6.2, A.7.6.2
    - Emergency Lighting, 7.6.1
    - Fire Detection, 7.6.4
    - Fire Suppression, 7.6.5
      - Automatic Fire Suppression, 7.6.5.2
      - Portable Fire Extinguishers, 7.6.5.1
    - Limitation of Combustibles, 7.6.6
    - Smoke Management, 7.6.8
    - Special Hazards, 7.6.7
    - Telecommunications Equipment, 7.6.3
- Referenced Publications, Chap. 2**
- Risk Considerations, Chap. 4**
- Risk Factors, 4.1
  - Service Continuity Risks, 4.2
    - Evaluation of Loss of Operations, 4.2.1, A.4.2.1
    - Risk Management Considerations, 4.2.2

**-S-**

**Safe Location**  
Definition, 3.7.10

**Safety Factor**  
Definition, 3.7.11

**Safety Margin**  
Definition, 3.7.12

**Sampling Port**  
Definition, 3.5.3

**Shall**  
Definition, 3.2.4

**Signal-Processing Equipment**  
Definition, 3.6.6, A.3.6.6

**Signal-Processing Equipment Area**  
Definition, 3.4.9

**Small Unoccupied Structures**, Chap. 11  
General, 11.2  
Scope, 11.1

**Smoke Control**  
Definition, 3.3.14

**Smoke Management**, Annex D

**Smoke Management System**  
Definition, 3.3.15

**Smoke Removal**  
Definition, 3.3.16

**Standard**  
Definition, 3.2.5

**Standard Fire Detection (SFD) Systems**  
Definition, 3.5.4

**Standby Engine Area**  
Definition, 3.4.10

**Standby Engine Equipment**

Definition, 3.6.7

**-T-****Technical Support Area**

Definition, 3.4.11, A.3.4.11

**Telecommunications**

Definition, 3.3.17

**Telecommunications Equipment**

Definition, 3.6.8

**Telecommunications Equipment Area**

Definition, 3.4.12, A.3.4.12

**Telecommunications Facility**

Definition, 3.3.18

**-U-****Utility**

Definition, 3.3.19

**-V-****Verification Method**

Definition, 3.7.13

**Very Early Warning Fire Detection (VEWFD) Systems**

Definition, 3.5.5

**Voice over Internet Protocol (VoIP)**

Definition, 3.3.20, A.3.3.20

**-W-****Walk-In Cabinet**

Definition, 3.3.21



## *Sequence of Events for the Standards Development Process*

Once the current edition is published, a Standard is opened for Public Input.

### **Step 1 – Input Stage**

- Input accepted from the public or other committees for consideration to develop the First Draft
- Technical Committee holds First Draft Meeting to revise Standard (23 weeks); Technical Committee(s) with Correlating Committee (10 weeks)
- Technical Committee ballots on First Draft (12 weeks); Technical Committee(s) with Correlating Committee (11 weeks)
- Correlating Committee First Draft Meeting (9 weeks)
- Correlating Committee ballots on First Draft (5 weeks)
- First Draft Report posted on the document information page

### **Step 2 – Comment Stage**

- Public Comments accepted on First Draft (10 weeks) following posting of First Draft Report
- If Standard does not receive Public Comments and the Technical Committee chooses not to hold a Second Draft meeting, the Standard becomes a Consent Standard and is sent directly to the Standards Council for issuance (see Step 4) or
- Technical Committee holds Second Draft Meeting (21 weeks); Technical Committee(s) with Correlating Committee (7 weeks)
- Technical Committee ballots on Second Draft (11 weeks); Technical Committee(s) with Correlating Committee (10 weeks)
- Correlating Committee Second Draft Meeting (9 weeks)
- Correlating Committee ballots on Second Draft (8 weeks)
- Second Draft Report posted on the document information page

### **Step 3 – NFPA Technical Meeting**

- Notice of Intent to Make a Motion (NITMAM) accepted (5 weeks) following the posting of Second Draft Report
- NITMAMs are reviewed and valid motions are certified by the Motions Committee for presentation at the NFPA Technical Meeting
- NFPA membership meets each June at the NFPA Technical Meeting to act on Standards with “Certified Amending Motions” (certified NITMAMs)
- Committee(s) vote on any successful amendments to the Technical Committee Reports made by the NFPA membership at the NFPA Technical Meeting

### **Step 4 – Council Appeals and Issuance of Standard**

- Notification of intent to file an appeal to the Standards Council on Technical Meeting action must be filed within 20 days of the NFPA Technical Meeting
- Standards Council decides, based on all evidence, whether to issue the standard or to take other action

#### **Notes:**

1. Time periods are approximate; refer to published schedules for actual dates.
2. Annual revision cycle documents with certified amending motions take approximately 101 weeks to complete.
3. Fall revision cycle documents receiving certified amending motions take approximately 141 weeks to complete.

## *Committee Membership Classifications<sup>1,2,3,4</sup>*

The following classifications apply to Committee members and represent their principal interest in the activity of the Committee.

1. M *Manufacturer*: A representative of a maker or marketer of a product, assembly, or system, or portion thereof, that is affected by the standard.
2. U *User*: A representative of an entity that is subject to the provisions of the standard or that voluntarily uses the standard.
3. IM *Installer/Maintainer*: A representative of an entity that is in the business of installing or maintaining a product, assembly, or system affected by the standard.
4. L *Labor*: A labor representative or employee concerned with safety in the workplace.
5. RT *Applied Research/Testing Laboratory*: A representative of an independent testing laboratory or independent applied research organization that promulgates and/or enforces standards.
6. E *Enforcing Authority*: A representative of an agency or an organization that promulgates and/or enforces standards.
7. I *Insurance*: A representative of an insurance company, broker, agent, bureau, or inspection agency.
8. C *Consumer*: A person who is or represents the ultimate purchaser of a product, system, or service affected by the standard, but who is not included in (2).
9. SE *Special Expert*: A person not representing (1) through (8) and who has special expertise in the scope of the standard or portion thereof.

NOTE 1: “Standard” connotes code, standard, recommended practice, or guide.

NOTE 2: A representative includes an employee.

NOTE 3: While these classifications will be used by the Standards Council to achieve a balance for Technical Committees, the Standards Council may determine that new classifications of member or unique interests need representation in order to foster the best possible Committee deliberations on any project. In this connection, the Standards Council may make such appointments as it deems appropriate in the public interest, such as the classification of “Utilities” in the National Electrical Code Committee.

NOTE 4: Representatives of subsidiaries of any group are generally considered to have the same classification as the parent organization.

## *Submitting Public Input / Public Comment Through the Online Submission System*

Following publication of the current edition of an NFPA standard, the development of the next edition begins and the standard is open for Public Input.

### **Submit a Public Input**

NFPA accepts Public Input on documents through our online submission system at [www.nfpa.org](http://www.nfpa.org). To use the online submission system:

- Choose a document from the List of NFPA codes & standards or filter by Development Stage for “codes accepting public input.”
- Once you are on the document page, select the “Next Edition” tab.
- Choose the link “The next edition of this standard is now open for Public Input.” You will be asked to sign in or create a free online account with NFPA before using this system.
- Follow the online instructions to submit your Public Input (see [www.nfpa.org/publicinput](http://www.nfpa.org/publicinput) for detailed instructions).
- Once a Public Input is saved or submitted in the system, it can be located on the “My Profile” page by selecting the “My Public Inputs/Comments/NITMAMs” section.

### **Submit a Public Comment**

Once the First Draft Report becomes available there is a Public Comment period. Any objections or further related changes to the content of the First Draft must be submitted at the Comment Stage. To submit a Public Comment follow the same steps as previously explained for the submission of Public Input.

### **Other Resources Available on the Document Information Pages**

**Header:** View document title and scope, access to our codes and standards or NFCSS subscription, and sign up to receive email alerts.



Research current and previous edition information.



Follow the committee’s progress in the processing of a standard in its next revision cycle.



View current committee rosters or apply to a committee.



For members, officials, and AHJs to submit standards questions to NFPA staff. Our Technical Questions Service provides a convenient way to receive timely and consistent technical assistance when you need to know more about NFPA standards relevant to your work.



Provides links to available articles and research and statistical reports related to our standards.



Discover and purchase the latest products and training.



View related publications, training, and other resources available for purchase.

## *Information on the NFPA Standards Development Process*

**I. Applicable Regulations.** The primary rules governing the processing of NFPA standards (codes, standards, recommended practices, and guides) are the NFPA *Regulations Governing the Development of NFPA Standards (Regs)*. Other applicable rules include NFPA *Bylaws*, NFPA *Technical Meeting Convention Rules*, NFPA *Guide for the Conduct of Participants in the NFPA Standards Development Process*, and the NFPA *Regulations Governing Petitions to the Board of Directors from Decisions of the Standards Council*. Most of these rules and regulations are contained in the *NFPA Standards Directory*. For copies of the *Directory*, contact Codes and Standards Administration at NFPA headquarters; all these documents are also available on the NFPA website at “[www.nfpa.org/regs](http://www.nfpa.org/regs).”

The following is general information on the NFPA process. All participants, however, should refer to the actual rules and regulations for a full understanding of this process and for the criteria that govern participation.

**II. Technical Committee Report.** The Technical Committee Report is defined as “the Report of the responsible Committee(s), in accordance with the Regulations, in preparation of a new or revised NFPA Standard.” The Technical Committee Report is in two parts and consists of the First Draft Report and the Second Draft Report. (See *Regs* at Section 1.4.)

**III. Step 1: First Draft Report.** The First Draft Report is defined as “Part one of the Technical Committee Report, which documents the Input Stage.” The First Draft Report consists of the First Draft, Public Input, Committee Input, Committee and Correlating Committee Statements, Correlating Notes, and Ballot Statements. (See *Regs* at 4.2.5.2 and Section 4.3.) Any objection to an action in the First Draft Report must be raised through the filing of an appropriate Comment for consideration in the Second Draft Report or the objection will be considered resolved. [See *Regs* at 4.3.1(b).]

**IV. Step 2: Second Draft Report.** The Second Draft Report is defined as “Part two of the Technical Committee Report, which documents the Comment Stage.” The Second Draft Report consists of the Second Draft, Public Comments with corresponding Committee Actions and Committee Statements, Correlating Notes and their respective Committee Statements, Committee Comments, Correlating Revisions, and Ballot Statements. (See *Regs* at 4.2.5.2 and Section 4.4.) The First Draft Report and the Second Draft Report together constitute the Technical Committee Report. Any outstanding objection following the Second Draft Report must be raised through an appropriate Amending Motion at the NFPA Technical Meeting or the objection will be considered resolved. [See *Regs* at 4.4.1(b).]

**V. Step 3a: Action at NFPA Technical Meeting.** Following the publication of the Second Draft Report, there is a period during which those wishing to make proper Amending Motions on the Technical Committee Reports must signal their intention by submitting a Notice of Intent to Make a Motion (NITMAM). (See *Regs* at 4.5.2.) Standards that receive notice of proper Amending Motions (Certified Amending Motions) will be presented for action at the annual June NFPA Technical Meeting. At the meeting, the NFPA membership can consider and act on these Certified Amending Motions as well as Follow-up Amending Motions, that is, motions that become necessary as a result of a previous successful Amending Motion. (See 4.5.3.2 through 4.5.3.6 and Table 1, Columns 1-3 of *Regs* for a summary of the available Amending Motions and who may make them.) Any outstanding objection following action at an NFPA Technical Meeting (and any further Technical Committee consideration following successful Amending Motions, see *Regs* at 4.5.3.7 through 4.6.5) must be raised through an appeal to the Standards Council or it will be considered to be resolved.

**VI. Step 3b: Documents Forwarded Directly to the Council.** Where no NITMAM is received and certified in accordance with the *Technical Meeting Convention Rules*, the standard is forwarded directly to the Standards Council for action on issuance. Objections are deemed to be resolved for these documents. (See *Regs* at 4.5.2.5.)

**VII. Step 4a: Council Appeals.** Anyone can appeal to the Standards Council concerning procedural or substantive matters related to the development, content, or issuance of any document of the NFPA or on matters within the purview of the authority of the Council, as established by the *Bylaws* and as determined by the Board of Directors. Such appeals must be in written form and filed with the Secretary of the Standards Council (see *Regs* at Section 1.6). Time constraints for filing an appeal must be in accordance with 1.6.2 of the *Regs*. Objections are deemed to be resolved if not pursued at this level.

**VIII. Step 4b: Document Issuance.** The Standards Council is the issuer of all documents (see Article 8 of *Bylaws*). The Council acts on the issuance of a document presented for action at an NFPA Technical Meeting within 75 days from the date of the recommendation from the NFPA Technical Meeting, unless this period is extended by the Council (see *Regs* at 4.7.2). For documents forwarded directly to the Standards Council, the Council acts on the issuance of the document at its next scheduled meeting, or at such other meeting as the Council may determine (see *Regs* at 4.5.2.5 and 4.7.4).

**IX. Petitions to the Board of Directors.** The Standards Council has been delegated the responsibility for the administration of the codes and standards development process and the issuance of documents. However, where extraordinary circumstances requiring the intervention of the Board of Directors exist, the Board of Directors may take any action necessary to fulfill its obligations to preserve the integrity of the codes and standards development process and to protect the interests of the NFPA. The rules for petitioning the Board of Directors can be found in the *Regulations Governing Petitions to the Board of Directors from Decisions of the Standards Council* and in Section 1.7 of the *Regs*.

**X. For More Information.** The program for the NFPA Technical Meeting (as well as the NFPA website as information becomes available) should be consulted for the date on which each report scheduled for consideration at the meeting will be presented. To view the First Draft Report and Second Draft Report as well as information on NFPA rules and for up-to-date information on schedules and deadlines for processing NFPA documents, check the NFPA website ([www.nfpa.org/docinfo](http://www.nfpa.org/docinfo)) or contact NFPA Codes & Standards Administration at (617) 984-7246.

# Xchange

The Online Community of the  
National Fire Protection Association®



## CONNECT WITH YOUR PEERS FROM AROUND THE WORLD



**NFPA® Xchange™ is an online forum for finding and sharing knowledge among an open community of professionals worldwide.**

This educational tool and job aid allows you to explore content relevant to you, participate in discussions with peers and industry leaders, ask and answer questions, and receive expert advice.

Membership to NFPA Xchange is free and provides access to:

- An active community of more than **50,000 professionals collaborating** in a single place
- Insights and information on **trending topics, emerging issues, and new technologies**
- **Blogs and webinars for learning on-the-job skills, and forums** for submitting queries to be answered by peers and NFPA® technical staff
- **Job board for posting open positions and discovering employment opportunities** from NFPA and partner organizations
- **A robust collection of previously asked questions and subject matter** in a searchable database accessible anywhere, anytime, from any device

Have the resources you need by your side at all times. NFPA Xchange provides the knowledge and support to help you do your job better and help protect lives and property. **Join the conversation today!**



Join now for free at [nfpa.org/xchange-community](https://nfpa.org/xchange-community)



IT'S A BIG WORLD.  
LET'S PROTECT IT TOGETHER.®