

NFPA[®]

54

ANSI Z223.1

**National
Fuel Gas
Code**

2018



IMPORTANT NOTICES AND DISCLAIMERS CONCERNING AGA AND NFPA® STANDARDS

NOTICE AND DISCLAIMER OF LIABILITY CONCERNING THE USE OF AGA AND NFPA STANDARDS





NFPA® codes, standards, recommended practices, and guides (“NFPA Standards”), of which the document contained herein is one, and AGA’s Z223.1 are each developed through a consensus standards development process approved by the American National Standards Institute. These processes bring together volunteers representing varied viewpoints and interests to achieve consensus on fire and other safety issues. While the AGA and the NFPA each administer their own standards development process and establish rules to promote fairness in the development of consensus, neither one independently tests, evaluates, or verifies the accuracy of any information or the soundness of any judgments contained in their codes and standards.

The AGA and NFPA each disclaim liability for any personal injury, property, or other damages of any nature whatsoever, whether special, indirect, consequential or compensatory, directly or indirectly resulting from the publication, use of, or reliance on this document. The AGA and the NFPA also make no guaranty or warranty as to the accuracy or completeness of any information published herein.

In issuing and making this document available, neither the AGA nor the NFPA are undertaking to render professional or other services for or on behalf of any person or entity. Nor are the AGA or the NFPA undertaking to perform any duty owed by any person or entity to someone else. Anyone using this document should rely on his or her own independent judgment or, as appropriate, seek the advice of a competent professional in determining the exercise of reasonable care in any given circumstances.

Neither the AGA nor the NFPA have power, nor do either of them undertake, to police or enforce compliance with the contents of this document. Nor do the AGA or the NFPA list, certify, test, or inspect products, designs, or installations for compliance with this document. Any certification or other statement of compliance with the requirements of this document shall not be attributable to the AGA or the NFPA and is solely the responsibility of the certifier or maker of the statement.

REVISION SYMBOLS IDENTIFYING CHANGES FROM THE PREVIOUS EDITION

Text revisions are shaded. A  before a section number indicates that words within that section were deleted and a  to the left of a table or figure number indicates a revision to an existing table or figure. When a chapter was heavily revised, the entire chapter is marked throughout with the  symbol. Where one or more sections were deleted, a • is placed between the remaining sections. Chapters, annexes, sections, figures, and tables that are new are indicated with an .

Note that these indicators are a guide. Rearrangement of sections may not be captured in the markup, but users can view complete revision details in the First and Second Draft Reports located in the archived revision information section of each code at www.nfpa.org/docinfo. Any subsequent changes from the NFPA Technical Meeting, Tentative Interim Amendments, and Errata are also located there.



ALERT: THIS STANDARD HAS BEEN MODIFIED BY A TIA OR ERRATA

Users of NFPA codes, standards, recommended practices, and guides (“NFPA Standards”) should be aware that NFPA Standards may be amended from time to time through the issuance of a Tentative Interim Amendment (TIA) or corrected by Errata. An official NFPA Standard at any point in time consists of the current edition of the document together with any TIAs and Errata then in effect.

To determine whether an NFPA Standard has been amended through the issuance of TIAs or corrected by Errata, go to www.nfpa.org/docinfo to choose from the list of NFPA Standards or use the search feature to select the NFPA Standard number (e.g., NFPA 13). The document information page provides up-to-date document-specific information as well as postings of all existing TIAs and Errata. It also includes the option to register for an “Alert” feature to receive an automatic email notification when new updates and other information are posted regarding the document.

ISBN: 978-145591667-2 (Print)

ISBN: 978-145591668-9 (PDF)

ISBN: 978-145591787-7 (eBook)

IMPORTANT NOTICES AND DISCLAIMERS CONCERNING AGA AND NFPA® STANDARDS

ADDITIONAL NOTICES AND DISCLAIMERS

Updating of AGA and NFPA Standards

Users of NFPA codes, standards, recommended practices, and guides (“NFPA Standards”) and AGA Z223.1 should be aware that these documents may be superseded at any time by the issuance of new editions or may be amended from time to time through the issuance of Tentative Interim Amendments or corrected by Errata. An official NFPA or AGA document at any point in time consists of the current edition of the document together with any Tentative Interim Amendments and any Errata then in effect. In order to determine whether a given document is the current edition and whether it has been amended through the issuance of Tentative Interim Amendments or corrected through the issuance of Errata, consult appropriate NFPA publications such as the National Fire Codes® Subscription Service, visit the NFPA website at www.nfpa.org, or contact the AGA or NFPA at the addresses listed below.

Interpretations of AGA and NFPA Standards

A statement, written or oral, that is not processed in accordance with the interpretation procedures of the Z223 Committee or Section 6 of the Regulations Governing the Development of NFPA Standards shall not be considered the official position of the Z223 Committee or the NFPA or any of their respective Committees and shall not be considered to be, nor be relied upon as, a Formal Interpretation.

Patents

Neither the AGA nor the NFPA take any position with respect to the validity of any patent rights referenced in, related to, or asserted in connection with an AGA or NFPA document. The users of AGA and NFPA documents bear the sole responsibility for determining the validity of any such patent rights, as well as the risk of infringement of such rights, and the AGA and NFPA disclaim liability for the infringement of any patent resulting from the use of or reliance on AGA and NFPA documents.

AGA and NFPA adhere to the policy of the American National Standards Institute (ANSI) regarding the inclusion of patents in American National Standards (“the ANSI Patent Policy”), and hereby give the following notice pursuant to that policy:

NOTICE: The user’s attention is called to the possibility that compliance with an AGA or NFPA document may require use of an invention covered by patent rights. AGA and NFPA take no position as to the validity of any such patent rights or as to whether such patent rights constitute or include essential patent claims under the ANSI Patent Policy. If, in connection with the ANSI Patent Policy, a patent holder has filed a statement of willingness to grant licenses under these rights on reasonable and nondiscriminatory terms and conditions to applicants desiring to obtain such a license, copies of such filed statements can be obtained, on request, from NFPA. For further information, contact the NFPA at the address listed below.

Law and Regulations

Users of AGA and NFPA documents should consult applicable federal, state, and local laws and regulations. The AGA and the NFPA do not, by the publication of their codes, standards, recommended practices, and guides, intend to urge action that is not in compliance with applicable laws, and this document may not be construed as doing so.

Copyrights

This document is copyrighted by the AGA and the NFPA. It is made available for a wide variety of both public and private uses. These include both use, by reference, in laws and regulations, and use in private self-regulation, standardization, and the promotion of safe practices and methods. By making this document available for use and adoption by public authorities and private users, the AGA and the NFPA do not waive any rights in copyright to these documents.

Use of AGA and NFPA documents for regulatory purposes should be accomplished through adoption by reference. The term “adoption by reference” means the citing of title, edition, and publishing information only. Any deletions, additions, and changes desired by the adopting authority should be noted separately in the adopting instrument. In order to assist NFPA in following the uses made of its documents, adopting authorities are requested to notify the NFPA (Attention: Secretary, Standards Council) in writing of such use. For technical assistance and questions concerning adoption of AGA and NFPA documents, contact the AGA or the NFPA at the addresses below.

For Further Information

All questions or other communications relating to AGA and NFPA documents and all requests for information on AGA and NFPA procedures governing their codes and standards development process, including information on the procedures for requesting Formal Interpretations, for proposing Tentative Interim Amendments, and for proposing revisions to AGA or NFPA documents during regular revision cycles, should be sent to AGA headquarters, addressed to the attention of the Secretary, Accredited Standards Committee Z223, 400 N. Capitol Street, N.W., Washington, DC 20001 and to NFPA headquarters, addressed to the attention of the Secretary, Standards Council, NFPA, 1 Batterymarch Park, P.O. Box 9101, Quincy, MA 02269-9101; email: stds_admin@nfpa.org.

For more information about NFPA, visit the NFPA website at www.nfpa.org. All NFPA codes and standards can be viewed at no cost at www.nfpa.org/docinfo. For more information about AGA, visit the AGA website at www.aga.org.

Copyright © 2017 National Fire Protection Association® and the American Gas Association. All Rights Reserved.

NFPA® 54–2018

ANSI Z223.1–2018

National Fuel Gas Code

2018 Edition

This edition of NFPA 54, *National Fuel Gas Code*, was prepared by the Technical Committee on National Fuel Gas Code and acted on by NFPA at its June Association Technical Meeting held June 4–7, 2017, in Boston, MA. It was issued by the Standards Council on August 17, 2017, with an effective date of September 6, 2017, and supersedes all previous editions.

This document has been amended by one or more Tentative Interim Amendments (TIAs) and/or Errata. See “Codes & Standards” at www.nfpa.org for more information.

This edition of ANSI Z223.1/NFPA 54 was approved as an American National Standard on September 6, 2017. The ANSI designation is Z223.1-2018 approved on August 3, 2017. The NFPA designation is NFPA 54-2018.

Origin and Development of ANSI Z223.1/NFPA 54

This code offers criteria for the installation and operation of gas piping and gas equipment on consumers’ premises. It is the cumulative result of years of experience of many individuals and many organizations acquainted with the installation of gas piping and equipment designed for utilization of gaseous fuels. It is intended to promote public safety by providing requirements for the safe and satisfactory utilization of gas.

Changes in this code can become necessary from time to time. When any revision is deemed advisable, recommendations should be forwarded to the Secretary, Accredited Standards Committee Z223, 400 N. Capitol St. NW, Washington, DC 20001, and the Secretary, Standards Council, National Fire Protection Association, 1 Batterymarch Park, Quincy, MA 02169-7471.

Prior to 1974, the following three codes covered the installation of gas piping and appliances:

- (1) *American National Standard Installation of Gas Appliances and Gas Piping*, ANSI Z21.30 (NFPA 54)
- (2) *Installation of Gas Piping and Gas Equipment on Industrial Premises and Certain Other Premises*, ANSI Z83.1 (NFPA 54A)
- (3) *Fuel Gas Piping*, ASME B31.2

The first edition of the code was issued in 1974. It combined the requirements of the three predecessor documents. The American Gas Association and the National Fire Protection Association have continued co-sponsorship of the code following the first edition.

The second edition of the code, incorporating pertinent portions of B31.2, was issued in 1980, and reorganized the code to the current format. Subsequent editions were issued in 1984, 1988, 1992, 1996, 1999, and 2002, respectively. The scope of the code was expanded in 1988 to include piping systems up to and including 125 psi (862 kPa). Revision highlights from subsequent editions include:

The 2006 edition incorporated expanded steel, copper, and polyethylene pipe sizing tables. Requirements for appliance shutoff valves were revised to allow manifold systems with all shutoff valves in one location up to 50 ft (15 m) from the most remote appliance, and the chapters were reorganized by application.

The 2009 edition included allowing press-connect fittings for gas tubing systems, new requirements for bonding of CSST piping systems, expanded CSST sizing tables to recognize additional available sizes, new coverage of outdoor decorative appliances, and a new requirement to seal the annular space around the side wall vent penetrations.

The 2012 edition included revised fuel gas piping purging procedures that require outdoor purging of piping with larger pipe sizes or higher operating pressures and allows smaller or lower operating pressure piping to be purged indoors under specific conditions.

The 2015 edition revised the bonding requirements for CSST so that the bonding connection can be placed on any metallic fitting in the piping system as long as the bonding jumper does not exceed 75 ft (22 m) in length. Overpressure protection requirements were rewritten and overpressure protection is required on any system containing an appliance with a maximum inlet pressure of 14 in. w.c. (3.5 kPa) that is supplied with gas at the point of delivery at a pressure greater than 2 psig (14 kPa). Annex G, Recommended Procedure for Safety Inspection of an Existing Appliance Installation, was expanded and revised to reflect modern appliances and test methods.

In the 2018 edition, revisions to piping include allowing listed arc-resistant jacket or coated CSST to use the appliance's electrical grounding connector as the bonding means and recognizing stainless steel smooth wall pipe and tubing products as acceptable piping materials. The minimum allowed wall thickness of carbon and stainless steel pipe has been revised to Schedule 10 but joints on Schedule 10 pipe cannot be made with screwed fittings. Press-connect fittings have been added as an acceptable joining method for pipe.

Revisions to the venting requirements include requiring listing to the appropriate UL standards for plastic venting materials, factory-built chimneys, Type B and BW vents, chimney lining systems, and special gas vents. Direct vent clearances to building openings for appliances with an input above 150,000 Btu (44 kW) are to be in accordance with the appliance manufacturer's installation instructions.

Finally, in Chapter 9 a requirement has been added that an existing gas appliance installation be inspected for combustion air and venting code compliance when the building structure that it is installed in is modified with specific air infiltration-reducing changes.

**Technical Committee on National Fuel Gas Code
Joint Listing of NFPA 54 and ASC Z223 Committee**

Thomas R. Crane, *Chair*
Crane Engineering, MN [SE/SE]

Paul W. Cabot, *Nonvoting Secretary*
American Gas Association, DC [IM]
Rep. American Gas Association

Stephen V. Abernathy,† Piedmont Natural Gas, SC [ES]
Rep. American Gas Association

Hugo Aguilar,* International Association of Plumbing & Mechanical Officials, CA [E]

Dmitry Antonov, Intertek, NY [RT/AR-TL]

David Berning, A.O. Smith Corporation, SC [M/M]
Rep. Air-Conditioning, Heating, & Refrigeration Institute

Jonathan Brania, UL LLC, NC [RT/AR-TL]

James P. Brewer, Magic Sweep Corporation, VA [IM/I-M]
Rep. National Chimney Sweep Guild

Sidney L. Cavanaugh,† Cavanaugh Consulting, NM [I-M]
Rep. United Association

Shannon M. Corcoran, CSA Group, OH [RT/AR-TL]

Gerald G. Davis, Washington Gas, VA [IM/ES]
Rep. American Gas Association

Mike Deegan, Clearwater Gas System, FL [U/ES]
Rep. American Public Gas Association

John P. Doucette,† Connecticut Office of State Fire Marshal, CT [EA]

Glen A. Edgar, VenTech, OH [SE/SE]

Mark Fasel,* Viega LLC, IN [M]

Pennie L. Feehan,† Pennie L. Feehan Consulting, CA [M]
Rep. Copper Development Association

Alberto Jose Fossa,* MDJ, Assessoria & Engenharia Consultiva, Brasil [SE]
Rep. NFPA Latin American Section

Mike Gorham, Northwest Gas Company, MN [IM/ES]
Rep. National Propane Gas Association

Gregg A. Gress, International Code Council, IL [E/EA]

Roger W Griffith,* Griffith Engineering, TN [U]

Steen Hagensen, ENERVEX, GA [M/M]

William T. Hamilton, UGI Utilities Inc., PA [IM/ES]
Rep. American Gas Association

Patricio J. Himes, Sistemas de Energia, Mexico [U/ES]
Rep. Asociación Mexicana de Distribuidores de Gas

Peter T. Holmes,* Maine Fuel Board, ME [E]

Marek Kulik,* Technical Standards & Safety Authority, Canada [E]

Theodore C. Lemoff, Naples, FL [SE/SE]

Frank J. Mortimer, EMC Insurance Company, IA [I/I]
Rep. Property Casualty Insurers Association of America

James T. Osterhaus, Railroad Commission of Texas, TX [E/EA]

Andrea Lanier Papageorge, Southern Company Gas/AGL Resources, GA [IM/ES]
Rep. American Gas Association

Dale L. Powell,* Copper Development Association, Inc., PA [M]
Rep. Copper Development Association Inc.

Phillip H. Ribbs,* PHR Consultants, CA [L]
Rep. California State Pipe Trades Council

John "Jack" Scanlon,† Rheem Manufacturing Company, AL [M]
Rep. Air-Conditioning, Heating, and Refrigeration Institute

Lynne Simnick,† International Association of Plumbing & Mechanical Officials, CA [EA]

Eric C. Smith, Nevada LP-Gas Board, NV [E/EA]
Rep. International Fire Marshals Association

Kenneth Sons,† U.S. Department of the Interior, CO [EA]

Thomas R. Stroud,† Hearth, Patio & Barbeque Association, [M]

Don Surrena,† National Association of Home Builders, DC [I-M]

Peter C. Swim,* Whirlpool Corporation, MI [M]

Franklin R. Switzer, Jr., S-safe, Inc., NY [SE/SE]

Matthew B. Williams,† Association of Home Appliance Manufacturers, DC [M]

Alternates

Stephen V. Abernathy,* Piedmont Natural Gas, SC [IM]
Rep. American Gas Association
(Alt. to Andrea Lanier Papageorge)

Muhammad Ali,† Association of Home Appliance Manufacturers,
DC [M]
(Alt. to Matthew B. Williams)

Kody N. Daniel, EMC Insurance Companies, IA [I/I]
(Alt. to Frank J. Mortimer)

John P. Doucette,* State of CT Department of Administrative
Services, CT [E]
(Alt. to Peter T. Holmes)

Craig Drumheller,† National Association of Home Builders, DC [I-
M]
(Alt. to Don Surrena)

Pennie L. Feehan,* Pennie L. Feehan Consulting, CA [M]
Rep. Copper Development Association
(Alt. to Dale L. Powell)

Fred Grable, International Code Council, IL [E/EA]
(Alt. to Gregg A. Gress)

John Kory, CSA America, Inc., OH [RT/AR-TL]
(Alt. to Shannon M. Corcoran)

Laura E. Montville, NFPA Staff Liaison

Donald MacBride,† Dominion East Ohio, OH [ES]
Rep. American Gas Association
(Alt. to Gerald G. Davis)

April Dawn Richardson,* Railroad Commission of Texas, TX [E]
(Alt. to James T. Osterhaus)

John “Jack” Scanlon,* Rheem Manufacturing Company, AL [M]
Rep. Air-Conditioning, Heating, & Refrigeration Institute
(Alt. to David Berning)

Lynne Simnick,* International Association of Plumbing &
Mechanical Officials, CA [E]
(Alt. to Hugo Aguilar)

Jason Stanek, Metropolitan Utilities District (MUD), NE [IM/ES]
Rep. American Gas Association
(Alt. to William T. Hamilton)

Bruce J. Swiecicki, National Propane Gas Association, IL [IM/ES]
(Alt. to Mike Gorham)

Matthew W. Wilber,* Crane Engineering, MN [SE]
(Alt. to Thomas R. Crane)

*NFPA 54 Committee only. † Committee only. [NFPA Interest Category/ASC Z223 Interest Category]

This list represents the membership at the time the Committee was balloted on the final text of this edition. Since that time, changes in the membership may have occurred. A key to classifications is found at the back of the document.

NOTE: Membership on a committee shall not in and of itself constitute an endorsement of the Association or any document developed by the committee on which the member serves.

The National Fuel Gas Code Committee is a committee functioning jointly under American National Standards Institute Accredited Standard Committee Z223 procedures and the National Fire Protection Association and, accordingly, the National Fuel Gas Code bears two designations, ANSI Z223.1 and NFPA 54. In the ANSI context, the code is prepared by the Accredited Standards Committee on National Fuel Gas Code, Z223, sponsored by the American Gas Association (Administrative Secretariat). In the NFPA context, the committee is an NFPA Technical Committee submitted to ANSI under NFPA audited designation.

Committee Scope: This Committee shall have primary responsibility for documents on safety code for gas piping systems on consumers' premises and the installation of gas utilization equipment and accessories for use with fuel gases such as natural gas, manufactured gas, liquefied petroleum gas in the vapor phase, liquefied petroleum gas-air mixtures, or mixtures of these gases, including: a. The design, fabrication, installation, testing, operation, and maintenance of gas piping systems from the point of delivery to the connections with each gas utilization device. Piping systems covered by this Code are limited to a maximum operating pressure of 125 psig. For purposes of this Code, the point of delivery is defined as the outlet of the meter set assembly, or the outlet of the service regulator or service shutoff valve where no meter is provided. b. The installation of gas utilization equipment, related accessories, and their ventilation and venting systems.

Contents

| | | | |
|--------------------------------------------------------------------------------|--------|---------------------------------------------------------------------------------------|--------|
| Chapter 1 Administration | 54- 7 | Chapter 8 Inspection, Testing, and Purging | 54- 64 |
| 1.1 Scope. | 54- 7 | 8.1 Pressure Testing and Inspection. | 54- 64 |
| 1.2 Purpose. | 54- 8 | 8.2 Piping System Leak Check. | 54- 65 |
| 1.3 Retroactivity. | 54- 8 | 8.3 Purging Requirements. | 54- 65 |
| 1.4 Equivalency. | 54- 8 | | |
| 1.5 Enforcement. | 54- 8 | Chapter 9 Appliance, Equipment, and Accessory Installation | 54- 66 |
| Chapter 2 Referenced Publications | 54- 8 | 9.1 General. | 54- 66 |
| 2.1 General. | 54- 8 | 9.2 Accessibility and Clearance. | 54- 68 |
| 2.2 NFPA Publications. | 54- 8 | 9.3 Air for Combustion and Ventilation. | 54- 69 |
| 2.3 Other Publications. | 54- 8 | 9.4 Appliances on Roofs. | 54- 70 |
| 2.4 References for Extracts in Mandatory Sections. ... | 54- 9 | 9.5 Appliances in Attics. | 54- 71 |
| | | 9.6 Appliance and Equipment Connections to Building Piping. | 54- 71 |
| Chapter 3 Definitions | 54- 9 | 9.7 Electrical. | 54- 73 |
| 3.1 General. | 54- 9 | 9.8 Room Temperature Thermostats. | 54- 73 |
| 3.2 NFPA Official Definitions. | 54- 9 | | |
| 3.3 General Definitions. | 54- 10 | Chapter 10 Installation of Specific Appliances | 54- 73 |
| Chapter 4 General | 54- 17 | 10.1 General. | 54- 73 |
| 4.1 Qualified Agency. | 54- 17 | 10.2 Air-Conditioning Appliances (Gas-Fired Air Conditioners and Heat Pumps). | 54- 73 |
| 4.2 Interruption of Service. | 54- 17 | 10.3 Central Heating Boilers and Furnaces. | 54- 75 |
| 4.3 Prevention of Accidental Ignition. | 54- 17 | 10.4 Clothes Dryers. | 54- 77 |
| 4.4 Noncombustible Material. | 54- 17 | 10.5 Conversion Burners. | 54- 77 |
| Chapter 5 Gas Piping System Design, Materials, and Components | 54- 17 | 10.6 Decorative Appliances for Installation in Vented Fireplaces. | 54- 77 |
| 5.1 Piping Plan. | 54- 17 | 10.7 Gas Fireplaces, Vented. | 54- 78 |
| 5.2 Provision for Location of Point of Delivery. | 54- 17 | 10.8 Non-Recirculating Direct Gas-Fired Industrial Air Heaters. | 54- 78 |
| 5.3 Interconnections Between Gas Piping Systems. | 54- 17 | 10.9 Recirculating Direct Gas-Fired Industrial Air Heaters. | 54- 79 |
| 5.4 Sizing of Gas Piping Systems. | 54- 18 | 10.10 Duct Furnaces. | 54- 79 |
| 5.5 Operating Pressure. | 54- 18 | 10.11 Floor Furnaces. | 54- 80 |
| 5.6 Acceptable Piping Materials and Joining Methods. | 54- 18 | 10.12 Food Service Appliance, Floor-Mounted. | 54- 81 |
| 5.7 Gas Meters. | 54- 21 | 10.13 Food Service Appliances, Counter Appliances. | 54- 82 |
| 5.8 Gas Pressure Regulators. | 54- 21 | 10.14 Household Cooking Appliances. | 54- 82 |
| 5.9 Overpressure Protection Devices. | 54- 22 | 10.15 Illuminating Appliances. | 54- 82 |
| 5.10 Back Pressure Protection. | 54- 23 | 10.16 Incinerators, Commercial-Industrial. | 54- 83 |
| 5.11 Low-Pressure Protection. | 54- 23 | 10.17 Infrared Heaters. | 54- 83 |
| 5.12 Shutoff Valves. | 54- 23 | 10.18 Open-Top Broiler Units. | 54- 83 |
| 5.13 Excess Flow Valve(s). | 54- 23 | 10.19 Outdoor Cooking Appliances. | 54- 83 |
| 5.14 Expansion and Flexibility. | 54- 23 | 10.20 Pool Heaters. | 54- 83 |
| | | 10.21 Refrigerators. | 54- 84 |
| Chapter 6 Pipe Sizing | 54- 23 | 10.22 Room Heaters. | 54- 84 |
| 6.1 Pipe Sizing Methods. | 54- 23 | 10.23 Stationary Gas Engines. | 54- 84 |
| 6.2 Sizing Natural Gas Piping Systems. | 54- 23 | 10.24 Gas-Fired Toilets. | 54- 84 |
| 6.3 Sizing Propane Piping Systems. | 54- 23 | 10.25 Unit Heaters. | 54- 84 |
| 6.4 Sizing Equations. | 54- 23 | 10.26 Wall Furnaces. | 54- 85 |
| | | 10.27 Water Heaters. | 54- 85 |
| Chapter 7 Gas Piping Installation | 54- 59 | 10.28 Compressed Natural Gas (CNG) Vehicular Fuel Systems. | 54- 86 |
| 7.1 Installation of Underground Piping. | 54- 59 | 10.29 Appliances for Installation in Manufactured Housing. | 54- 86 |
| 7.2 Installation of Aboveground Piping. | 54- 61 | 10.30 Fuel Cell Power Plants. | 54- 86 |
| 7.3 Concealed Piping in Buildings. | 54- 61 | 10.31 Outdoor Open Flame Decorative Appliances. | 54- 86 |
| 7.4 Piping in Vertical Chases. | 54- 62 | | |
| 7.5 Gas Pipe Turns. | 54- 62 | Chapter 11 Procedures to Be Followed to Place Appliance in Operation | 54- 86 |
| 7.6 Drips and Sediment Traps. | 54- 62 | 11.1 Adjusting the Burner Input. | 54- 86 |
| 7.7 Outlets. | 54- 62 | 11.2 Primary Air Adjustment. | 54- 86 |
| 7.8 Manual Gas Shutoff Valves. | 54- 63 | 11.3 Safety Shutoff Devices. | 54- 86 |
| 7.9 Prohibited Devices. | 54- 63 | 11.4 Automatic Ignition. | 54- 86 |
| 7.10 Systems Containing Gas-Air Mixtures Outside the Flammable Range. | 54- 63 | 11.5 Protective Devices. | 54- 86 |
| 7.11 Systems Containing Flammable Gas-Air Mixtures. | 54- 63 | 11.6 Checking the Draft. | 54- 87 |
| 7.12 Electrical Bonding and Grounding. | 54- 64 | 11.7 Operating Instructions. | 54- 87 |
| 7.13 Electrical Circuits. | 54- 64 | | |
| 7.14 Electrical Connections. | 54- 64 | | |

| | | | |
|---------------------------------------------------------------------------------------|---------|---------------------------------------------------------------------------------------------------------------------------------------------------------------------|---------|
| Chapter 12 Venting of Appliances | 54– 87 | Annex C Suggested Method of Checking for Leakage | 54– 138 |
| 12.1 Minimum Safe Performance. | 54– 87 | Annex D Suggested Emergency Procedure for Gas Leaks | 54– 139 |
| 12.2 General. | 54– 87 | Annex E Flow of Gas Through Fixed Orifices | 54– 140 |
| 12.3 Specification for Venting. | 54– 87 | Annex F Sizing of Venting Systems Serving Appliances Equipped with Draft Hoods, Category I Appliances, and Appliances Listed for Use with Type B Vents | 54– 145 |
| 12.4 Design and Construction. | 54– 87 | Annex G Recommended Procedure for Safety Inspection of an Existing Appliance Installation | 54– 153 |
| 12.5 Type of Venting System to Be Used. | 54– 88 | Annex H Indoor Combustion Air Calculation Examples | 54– 158 |
| 12.6 Masonry, Metal, and Factory-Built Chimneys. | 54– 88 | Annex I Example of Combination of Indoor and Outdoor Combustion and Ventilation Opening Design | 54– 159 |
| 12.7 Gas Vents. | 54– 90 | Annex J Enforcement | 54– 160 |
| 12.8 Single-Wall Metal Pipe. | 54– 91 | Annex K Informational References | 54– 161 |
| 12.9 Through-the-Wall Vent Termination. | 54– 93 | Index | 54– 164 |
| 12.10 Condensation Drain. | 54– 93 | | |
| 12.11 Vent Connectors for Category I Appliances. | 54– 93 | | |
| 12.12 Vent Connectors for Category II, Category III, and Category IV Appliances. | 54– 95 | | |
| 12.13 Draft Hoods and Draft Controls. | 54– 95 | | |
| 12.14 Manually Operated Dampers. | 54– 95 | | |
| 12.15 Automatically Operated Vent Dampers. | 54– 96 | | |
| 12.16 Obstructions. | 54– 96 | | |
| Chapter 13 Sizing of Category I Venting Systems | 54– 96 | | |
| 13.1 Additional Requirements to Single Appliance Vent. | 54– 96 | | |
| 13.2 Additional Requirements to Multiple-Appliance Vent. | 54– 104 | | |
| Annex A Explanatory Material | 54– 116 | | |
| Annex B Sizing and Capacities of Gas Piping | 54– 129 | | |

NFPA 54

ANSI Z223.1–2018

National Fuel Gas Code

2018 Edition

IMPORTANT NOTE: This AGA and NFPA document is made available for use subject to important notices and legal disclaimers. These notices and disclaimers appear in all publications containing this document and may be found under the heading “Important Notices and Disclaimers Concerning AGA and NFPA Standards.” They can also be obtained on request from NFPA or viewed at www.nfpa.org/disclaimers.

UPDATES, ALERTS, AND FUTURE EDITIONS: New editions of NFPA codes, standards, recommended practices, and guides (i.e., NFPA Standards) are released on scheduled revision cycles. This edition may be superseded by a later one, or it may be amended outside of its scheduled revision cycle through the issuance of Tentative Interim Amendments (TIAs). An official NFPA Standard at any point in time consists of the current edition of the document, together with all TIAs and Errata in effect. To verify that this document is the current edition or to determine if it has been amended by TIAs or Errata, please consult the National Fire Codes® Subscription Service or the “List of NFPA Codes & Standards” at www.nfpa.org/docinfo. In addition to TIAs and Errata, the document information pages also include the option to sign up for alerts for individual documents and to be involved in the development of the next edition.

NOTICE: An asterisk (*) following the number or letter designating a paragraph indicates that explanatory material on the paragraph can be found in Annex A.

A reference in brackets [] following a section or paragraph indicates material that has been extracted from another NFPA document. As an aid to the user, the complete title and edition of the source documents for extracts in mandatory sections of the document are given in Chapter 2 and those for extracts in informational sections are given in Annex K. Extracted text may be edited for consistency and style and may include the revision of internal paragraph references and other references as appropriate. Requests for interpretations or revisions of extracted text shall be sent to the technical committee responsible for the source document.

Information on referenced publications can be found in Chapter 2 and Annex K.

All pressures used in this code are gauge pressure unless otherwise indicated.

Chapter 1 Administration

1.1 Scope.

1.1.1 Applicability.

1.1.1.1 This code is a safety code that shall apply to the installation of fuel gas piping systems, appliances, equipment, and related accessories as shown in 1.1.1.1(A) through 1.1.1.1(F).

(A)* Coverage of piping systems shall extend from the point of delivery to the appliance connections. For other than undiluted liquefied petroleum gas (LP-Gas) systems, the point of delivery shall be the outlet of the service meter assembly or the outlet of the service regulator or service shutoff valve where no meter is provided. For undiluted LP-Gas systems, the point of

delivery shall be considered to be the outlet of the final pressure regulator, exclusive of line gas regulators where no meter is installed. Where a meter is installed, the point of delivery shall be the outlet of the meter.

(B) This code shall apply to natural gas systems operating at a pressure of 125 psi (862 kPa) or less.

(C) This code shall apply to LP-Gas systems operating at a pressure of 50 psi (345 kPa) or less.

(D) This code shall apply to gas–air mixture systems operating within the flammable range at a pressure of 10 psi (69 kPa) or less.

(E) Requirements for piping systems shall include design, materials, components, fabrication, assembly, installation, testing, inspection, operation, and maintenance.

(F) Requirements for appliances, equipment, and related accessories shall include installation, combustion, and ventilation air and venting.

▲ 1.1.1.2 This code shall not apply to the following items:

- (1) Portable LP-Gas appliances and equipment of all types that are not connected to a fixed fuel piping system
- (2) Installation of appliances such as brooders, dehydrators, dryers, and irrigation equipment used for agricultural purposes
- (3) Raw material (feedstock) applications except for piping to special atmosphere generators
- (4) Oxygen–fuel gas cutting and welding systems
- (5) Industrial gas applications using such gases as acetylene and acetylenic compounds, hydrogen, ammonia, carbon monoxide, oxygen, and nitrogen
- (6) Petroleum refineries, pipeline compressor or pumping stations, loading terminals, compounding plants, refinery tank farms, and natural gas processing plants
- (7) Large integrated chemical plants or portions of such plants where flammable or combustible liquids or gases are produced by chemical reactions or used in chemical reactions
- (8) LP-Gas installations at utility gas plants
- (9) Liquefied natural gas (LNG) installations
- (10) Fuel gas piping in electric utility power plants
- (11) Proprietary items of equipment, apparatus, or instruments such as gas generating sets, compressors, and calorimeters
- (12) LP-Gas equipment for vaporization, gas mixing, and gas manufacturing
- (13) LP-Gas piping for buildings under construction or renovations that is not to become part of the permanent building piping system — that is, temporary fixed piping for building heat
- (14) Installation of LP-Gas systems for railroad switch heating
- (15) Installation of LP-Gas and compressed natural gas (CNG) systems on vehicles
- (16) Gas piping, meters, gas pressure regulators, and other appurtenances used by the serving gas supplier in distribution of gas, other than undiluted LP-Gas
- (17) Building design and construction, except as specified herein
- (18) Fuel gas systems on recreational vehicles manufactured in accordance with NFPA 1192
- (19) Fuel gas systems using hydrogen as a fuel
- (20) Construction of appliances

1.1.2 Other Standards. In applying this code, reference shall also be made to the manufacturers' instructions and the serving gas supplier regulations.

1.2 Purpose. (Reserved)

1.3 Retroactivity. Unless otherwise stated, the provisions of this code shall not be applied retroactively to existing systems that were in compliance with the provisions of the code in effect at the time of installation.

1.4 Equivalency. The provisions of this code are not intended to prevent the use of any material, method of construction, or installation procedure not specifically prescribed by this code, provided any such alternative is acceptable to the authority having jurisdiction. The authority having jurisdiction shall require that sufficient evidence be submitted to substantiate any claims made regarding the safety of such alternatives.

1.5 Enforcement. This code shall be administered and enforced by the authority having jurisdiction designated by the governing authority.

Chapter 2 Referenced Publications

2.1 General. The documents or portions thereof listed in this chapter are referenced within this code and shall be considered part of the requirements of this document.

2.2 NFPA Publications. National Fire Protection Association, 1 Batterymarch Park, Quincy, MA 02169-7471.

NFPA 30A, *Code for Motor Fuel Dispensing Facilities and Repair Garages*, 2018 edition.

NFPA 37, *Standard for the Installation and Use of Stationary Combustion Engines and Gas Turbines*, 2018 edition.

NFPA 51, *Standard for the Design and Installation of Oxygen–Fuel Gas Systems for Welding, Cutting, and Allied Processes*, 2018 edition.

NFPA 52, *Vehicular Natural Gas Fuel Systems Code*, 2016 edition.

NFPA 58, *Liquefied Petroleum Gas Code*, 2017 edition.

NFPA 70®, *National Electrical Code®*, 2017 edition.

NFPA 82, *Standard on Incinerators and Waste and Linen Handling Systems and Equipment*, 2014 edition.

NFPA 88A, *Standard for Parking Structures*, 2015 edition.

NFPA 90A, *Standard for the Installation of Air-Conditioning and Ventilating Systems*, 2018 edition.

NFPA 90B, *Standard for the Installation of Warm Air Heating and Air-Conditioning Systems*, 2018 edition.

NFPA 96, *Standard for Ventilation Control and Fire Protection of Commercial Cooking Operations*, 2017 edition.

NFPA 211, *Standard for Chimneys, Fireplaces, Vents, and Solid Fuel–Burning Appliances*, 2016 edition.

NFPA 409, *Standard on Aircraft Hangars*, 2016 edition.

NFPA 780, *Standard for the Installation of Lightning Protection Systems*, 2017 edition.

NFPA 853, *Standard for the Installation of Stationary Fuel Cell Power Systems*, 2015 edition.

NFPA 1192, *Standard on Recreational Vehicles*, 2018 edition.

2.3 Other Publications.

▲ **2.3.1 ASME Publications.** American Society of Mechanical Engineers, Two Park Avenue, New York, NY 10016-5990, (800) 843-2763, www.asme.org.

ANSI/ASME B1.20.1, *Pipe Threads, General Purpose, Inch*, 2013.

ANSI/ASME B16.1, *Gray Iron Pipe Flanges and Flanged Fittings: Classes 25, 125, and 250*, 2010.

ANSI/ASME B16.5, *Pipe Flanges and Flanged Fittings: NPS ½ through NPS 24 Metric/Inch Standard*, 2013.

ANSI/ASME B16.20, *Metallic Gaskets for Pipe Flanges: Ring-Joint, Spiral-Wound and Jacketed*, 2012.

ANSI/ASME B16.21, *Nonmetallic Flat Gaskets for Pipe Flanges*, 2011.

ANSI/ASME B16.24, *Cast Copper Alloy Pipe Flanges and Flanged Fittings: Classes 150, 300, 600, 900, 1500, and 2500*, 2011.

ANSI/ASME B16.42, *Ductile Iron Pipe Flanges and Flanged Fittings: Classes 150 and 300*, 2011.

ANSI/ASME B16.47, *Large Diameter Steel Flanges: NPS 26 through NPS 60 Metric/Inch Standard*, 2011.

ANSI/ASME B36.10M, *Welded and Seamless Wrought Steel Pipe*, 2015.

▲ **2.3.2 ASTM Publications.** ASTM International, 100 Barr Harbor Drive, P.O. Box C700, West Conshohocken, PA 19428-2959, (610) 832-9585, www.astm.org.

ASTM A53, *Standard Specification for Pipe, Steel, Black and Hot-Dipped, Zinc-Coated Welded and Seamless*, 2012.

ASTM A106, *Standard Specification for Seamless Carbon Steel Pipe for High-Temperature Service*, 2014.

ASTM A254, *Standard Specification for Copper-Brazed Steel Tubing*, 2012.

ASTM A268, *Standard Specification for Seamless and Welded Ferritic and Martensitic Stainless Steel Tubing for General Service*, 2010.

ASTM A269, *Standard Specification for Seamless and Welded Austenitic Stainless Steel Tubing for General Service*, 2015.

ASTM A312, *Standard Specification for Seamless, Welded, and Heavily Cold Worked Austenitic Stainless Steel Pipes*, 2015.

ASTM B88, *Standard Specification for Seamless Copper Water Tube*, 2014.

ASTM B210, *Standard Specification for Aluminum and Aluminum-Alloy Drawn Seamless Tubes*, 2012.

ASTM B241, *Standard Specification for Aluminum and Aluminum-Alloy Seamless Pipe and Seamless Extruded Tube*, 2012.

ASTM B280, *Standard Specification for Seamless Copper Tube for Air-Conditioning and Refrigeration Field Service*, 2013.

ASTM D2513, *Standard Specification for Polyethylene (PE) Gas Pressure Pipe, Tubing, and Fittings*, 2014.

ASTM E136, *Standard Test Method for Behavior of Materials in a Vertical Tube Furnace at 750°C*, 2012.

ASTM E2652, *Standard Test Method for Behavior of Materials in a Tube Furnace with a Cone-shaped Airflow Stabilizer, at 750 °C*, 2012.

ASTM F1973, *Standard Specification for Factory Assembled Anodeless Risers and Transition Fittings in Polyethylene (PE) and Polyamide 11 (PA11) and Polyamide 12 (PA12) Fuel Gas Distribution Systems*, 2013.

ASTM F2509, *Standard Specification for Field-Assembled Anodeless Riser Kits for Use on Outside Diameter Controlled Polyethylene Gas Distribution Pipe and Tubing*, 2012.

ASTM F2945, *Standard Specification for Polyamide 11 Gas Pressure Pipe, Tubing, and Fittings*, 2015.

2.3.3 CSA Group Publications. CSA Group, 178 Rexdale Boulevard, Toronto, ON M9W 1R3, Canada, (216) 524-4990, www.csagroup.org.

ANSI/CSA NGV 5.1, *Residential Fueling Appliances*, 2015.

ANSI LC 1/CSA 6.26, *Fuel Gas Piping Systems Using Corrugated Stainless Steel Tubing (CSST)*, 2014.

ANSI LC 4/CSA 6.32, *Press-Connect Metallic Fittings for Use in Fuel Gas Distribution Systems*, 2012.

ANSI Z21.8, *Installation of Domestic Gas Conversion Burners*, 1994, reaffirmed 2012.

ANSI Z21.11.2, *Gas-Fired Room Heaters — Volume II, Unvented Room Heaters*, 2013.

ANSI Z21.24/CSA 6.10, *Connectors for Gas Appliances*, 2015.

ANSI Z21.41/CSA 6.9, *Quick-Disconnect Devices for Use with Gas Fuel Appliances*, 2014.

ANSI Z21.54/CSA 8.4, *Gas Hose Connectors for Portable Outdoor Gas-Fired Appliances*, 2014.

ANSI Z21.69/CSA 6.16, *Connectors for Movable Gas Appliances*, 2009.

ANSI Z21.75/CSA 6.27, *Connectors for Outdoor Gas Appliances and Manufactured Homes*, 2007, reaffirmed 2012.

ANSI Z21.80/CSA 6.22, *Line Pressure Regulators*, 2011.

ANSI Z21.90/CSA 6.24, *Gas Convenience Outlets and Optional Enclosures*, 2015.

ANSI Z21.93/CSA 6.30, *Excess Flow Valves for Natural and LP-Gas with Pressures Up to 5 psig*, 2013.

ANSI Z83.4/CSA 3.7, *Non-Recirculating Direct Gas-Fired Industrial Air Heaters*, 2015.

ANSI Z83.18, *Recirculating Direct Gas-Fired Industrial Air Heaters*, 2015.

2.3.4 MSS Publications. Manufacturers Standardization Society of the Valve and Fittings Industry, 127 Park Street, NE, Vienna, VA 22180-4602, (703) 281-6613, www.msshq.org.

ANSI/MSS SP-58, *Pipe Hangers and Supports — Materials, Design, Manufacture, Selection, Application, and Installation*, 2009.

2.3.5 UL Publications. Underwriters Laboratories Inc., 333 Pfingsten Road, Northbrook, IL 60062-2096, www.ul.com.

ANSI/UL 103, *Chimneys, Factory-Built, Residential Type and Building Heating Appliances*, 2010, reapproved 2012.

ANSI/UL 441, *Gas Vents*, 2010, reapproved 2014.

ANSI/UL 467, *Grounding and Bonding Equipment*, 2013.

ANSI/UL 641, *Type L Low-Temperature Venting Systems*, 2010, reapproved 2013.

ANSI/UL 651, *Schedule 40 and 80 Rigid PVC Conduit and Fittings*, 2011, reapproved 2014.

ANSI/UL 959, *Medium Heat Appliance Factory-Built Chimneys*, 2010, reapproved 2014.

ANSI/UL 1738, *Venting Systems for Gas Burning Appliances, Categories II, III and IV*, 2010, reapproved 2014.

ANSI/UL 1777, *Chimney Liners*, 2015.

ANSI/UL 2158A, *Clothes Dryer Transition Ducts*, 2013.

ANSI/UL 2561, *1400 Degree Fahrenheit Factory-Built Chimneys*, 2009, reapproved 2013.

UL 378, *Draft Equipment*, 2006, reapproved 2013.

2.3.6 U.S. Government Publications. U.S. Government Publishing Office, Washington, DC 20401-0001, www.gpo.gov.

Title 49, Code of Federal Regulations, Part 192, "Transportation of Natural and Other Gas by Pipeline: Minimum Federal Standards."

2.3.7 Other Publications.

Merriam-Webster's Collegiate Dictionary, 11th edition, Merriam-Webster, Inc., Springfield, MA, 2003.

▲ 2.4 References for Extracts in Mandatory Sections.

NFPA 31, *Standard for the Installation of Oil-Burning Equipment*, 2016 edition.

NFPA 70®, *National Electrical Code®*, 2017 edition.

NFPA 88A, *Standard for Parking Structures*, 2015 edition.

NFPA 90A, *Standard for the Installation of Air-Conditioning and Ventilating Systems*, 2015 edition.

NFPA 101®, *Life Safety Code®*, 2015 edition.

NFPA 501, *Standard on Manufactured Housing*, 2017 edition.

NFPA 5000®, *Building Construction and Safety Code®*, 2015 edition.

Chapter 3 Definitions

3.1 General. The definitions contained in this chapter shall apply to the terms used in this code. Where terms are not defined in this chapter or within another chapter, they shall be defined using their ordinarily accepted meanings within the context in which they are used. *Merriam-Webster's Collegiate Dictionary*, 11th edition, shall be the source for the ordinarily accepted meaning.

3.2 NFPA Official Definitions.

3.2.1* Approved. Acceptable to the authority having jurisdiction.

3.2.2* Authority Having Jurisdiction (AHJ). An organization, office, or individual responsible for enforcing the requirements of a code or standard, or for approving equipment, materials, an installation, or a procedure.

3.2.3* Code. A standard that is an extensive compilation of provisions covering broad subject matter or that is suitable for adoption into law independently of other codes and standards.

3.2.4 Labeled. Equipment or materials to which has been attached a label, symbol, or other identifying mark of an organization that is acceptable to the authority having jurisdiction and concerned with product evaluation, that maintains periodic inspection of production of labeled equipment or materials, and by whose labeling the manufacturer indicates compliance with appropriate standards or performance in a specified manner.

3.2.5* Listed. Equipment, materials, or services included in a list published by an organization that is acceptable to the authority having jurisdiction and concerned with evaluation of products or services, that maintains periodic inspection of production of listed equipment or materials or periodic evaluation of services, and whose listing states that either the equipment, material, or service meets appropriate designated standards or has been tested and found suitable for a specified purpose.

3.2.6 Shall. Indicates a mandatory requirement.

3.3 General Definitions.

3.3.1 Accessible. Having access to but which first requires the removal of a panel, door, or similar covering of the item described.

3.3.1.1 Readily Accessible. Having direct access without the need of removing or moving any panel, door, or similar covering of the item described.

3.3.2 Air.

3.3.2.1 Circulating Air. Air for cooling, heating, or ventilation distributed to habitable spaces.

3.3.2.2 Dilution Air. Air that enters a draft hood or draft regulator and mixes with the flue gases.

3.3.2.3 Excess Air. Air that passes through the combustion chamber and the appliance flues in excess of that which is theoretically required for complete combustion.

3.3.2.4 Primary Air. The air introduced into a burner that mixes with the gas before it reaches the port or ports.

3.3.3 Air Conditioning. The treatment of air so as to control simultaneously its temperature, humidity, cleanness, and distribution to meet the requirements of a conditioned space.

3.3.4 Anodeless Riser. An assembly of steel-cased plastic pipe used to make the transition between plastic piping installed underground and metallic piping installed aboveground.

3.3.5 Appliance. Any device that utilizes a fuel to produce light, heat, power, refrigeration, or air conditioning.

3.3.5.1 Automatically Controlled Appliance. Appliance equipped with an automatic burner ignition and safety shutoff device and other automatic devices.

3.3.5.2 Decorative Appliance for Installation in a Vented Fireplace. A self-contained, freestanding, fuel gas-burning appliance designed for installation only in a vented fireplace and whose primary function lies in the aesthetic effect of the flame.

3.3.5.3 Direct Vent Appliances. Appliances that are constructed and installed so that all air for combustion is derived directly from the outdoors and all flue gases are discharged to the outdoors.

3.3.5.4 Fan-Assisted Combustion Appliance. An appliance equipped with an integral mechanical means to either draw or force products of combustion through the combustion chamber or heat exchanger.

3.3.5.5 Food Service Appliance.

3.3.5.5.1 Baking and Roasting Gas Oven. An oven primarily intended for volume food preparation that is composed of one or more sections or units of the following types: (1) cabinet oven, an oven having one or more cavities heated by a single burner or group of burners; (2) reel-type oven, an oven employing trays that are moved by mechanical means; or (3) sectional oven, an oven composed of one or more independently heated cavities.

3.3.5.5.2 Gas Counter Appliance. An appliance such as a gas coffee brewer and coffee urn and any appurtenant water heating appliance, food and dish warmer, hot plate, and griddle.

3.3.5.5.3 Gas Deep Fat Fryer. An appliance, including a cooking vessel in which oils or fats are placed to such a depth that the cooking food is essentially supported by displacement of the cooking fluid or a perforated container immersed in the cooking fluid rather than by the bottom of the vessel, designed primarily for use in hotels, restaurants, clubs, and similar institutions.

3.3.5.5.4 Gas Range. A self-contained gas range providing for cooking, roasting, baking, or broiling, or any combination of these functions, and not designed specifically for domestic use.

3.3.5.5.5 Gas Steam Cooker. An appliance that cooks, defrosts, or reconstitutes food by direct contact with steam.

3.3.5.5.6 Gas Steam Generator. A separate appliance primarily intended to supply steam for use with food service appliances.

3.3.5.5.7 Kettle. An appliance with a cooking chamber that is heated either by a steam jacket in which steam is generated by gas heat or by direct gas heat applied to the cooking chamber.

3.3.5.6 Gas Counter Appliances. See 3.3.5.5.2.

3.3.5.7 Household Cooking Appliance. An appliance for domestic food preparation, providing at least one function of (1) top or surface cooking, (2) oven cooking, or (3) broiling.

3.3.5.7.1 Household Broiler Cooking Appliance. A unit that cooks primarily by radiated heat.

3.3.5.7.2 Household Built-In Unit Cooking Appliance. A unit designed to be recessed into, placed upon, or attached to the construction of a building, but not for installation on the floor.

3.3.5.8 Nonresidential, Low-Heat Appliance. An appliance needing a chimney capable of withstanding a continuous flue gas temperature not exceeding 1000°F (538°C).

3.3.5.9 Nonresidential, Medium-Heat Appliance. An appliance needing a chimney capable of withstanding a continuous flue gas temperature not exceeding 1800°F (982°C).

3.3.5.10 Outdoor Cooking Appliance. A gas-fired cooking appliance for outdoor use only that is provided with a means of support by the manufacturer and is connected to a fixed gas piping system.

3.3.5.11 Vented Appliance.

3.3.5.11.1* Category I Vented Appliance. An appliance that operates with a nonpositive vent static pressure and with a vent gas temperature that avoids excessive condensate production in the vent.

3.3.5.11.2 Category II Vented Appliance. An appliance that operates with a nonpositive vent static pressure and with a vent gas temperature that can cause excessive condensate production in the vent.

3.3.5.11.3 Category III Vented Appliance. An appliance that operates with a positive vent static pressure and with a vent gas temperature that avoids excessive condensate production in the vent.

3.3.5.11.4 Category IV Vented Appliance. An appliance that operates with a positive vent static pressure and with a vent gas temperature that can cause excessive condensate production in the vent.

3.3.6 Appliance Categorized Vent Diameter/Area. The minimum vent diameter/area permissible for Category I appliances to maintain a nonpositive vent static pressure when tested in accordance with nationally recognized standards.

3.3.7 Automatic Firecheck. A device for stopping the progress of a flame front in burner mixture lines (flashback) and for automatically shutting off the fuel-air mixture.

3.3.8 Automatic Vent Damper. A device that is intended for installation in the venting system, in the outlet of or downstream of the appliance draft hood, of an individual automatically operated appliance and that is designed to automatically open the venting system when the appliance is in operation and to automatically close off the venting system when the appliance is in a standby or shutdown condition.

3.3.9 Backfire Preventer. See 3.3.86, Safety Blowout.

3.3.10 Baffle. An object placed in an appliance to change the direction of or retard the flow of air, air-gas mixtures, or flue gases.

3.3.11 Boiler.

3.3.11.1 Hot Water Heating Boiler. A boiler designed to heat water for circulation through an external space heating system.

3.3.11.2 Hot Water Supply Boiler. A boiler used to heat water for purposes other than space heating.

3.3.11.3 Low Pressure Boiler. A boiler for generating steam at gauge pressures not in excess of 15 psi (gauge pressure of 103 kPa) or for furnishing water at a maximum temperature of 250°F (121°C) at a maximum gauge pressure of 160 psi (gauge pressure of 1100 kPa). [31, 2016]

3.3.11.4 Steam Boiler. A boiler designed to convert water into steam that is supplied to an external system.

3.3.12 Bonding Jumper. A reliable conductor to ensure the required electrical conductivity between metal parts required to be electrically connected. [70:100]

3.3.13 Branch Line. Gas piping that conveys gas from a supply line to the appliance.

3.3.14 Breeching. See 3.3.101, Vent Connector.

3.3.15 Broiler. A general term including broilers, salamanders, barbecues, and other devices cooking primarily by radiated heat, excepting toasters.

3.3.15.1 Unit Broiler. A broiler constructed as a separate appliance.

3.3.16 Btu. Abbreviation for British thermal unit, which is the quantity of heat required to raise the temperature of 1 pound of water 1 degree Fahrenheit (equivalent to 1055 joules).

3.3.17 Burner. A device for the final conveyance of gas, or a mixture of gas and air, to the combustion zone.

3.3.17.1 Forced-Draft Burner. See 3.3.17.5, Power Burner.

3.3.17.2 Gas Conversion Burner. A unit consisting of a burner and its controls utilizing gaseous fuel for installation in an appliance originally utilizing another fuel.

3.3.17.3 Injection- (Bunsen-) Type Burner. A burner employing the energy of a jet of gas to inject air for combustion into the burner and mix it with the gas.

3.3.17.4 Main Burner. A device or group of devices essentially forming an integral unit for the final conveyance of gas or a mixture of gas and air to the combustion zone and on which combustion takes place to accomplish the function for which the appliance is designed.

3.3.17.5 Power Burner. A burner in which either gas or air, or both, are supplied at a pressure exceeding, for gas, the line pressure, and for air, atmospheric pressure; this added pressure being applied at the burner. A burner for which air for combustion is supplied by a fan ahead of the appliance is commonly designated as a forced-draft burner.

3.3.17.5.1 Fan-Assisted Power Burner. A burner that uses either induced or forced draft.

3.3.18 Chimney. One or more passageways, vertical or nearly so, for conveying flue or vent gases to the outdoors.

3.3.18.1 Exterior Masonry Chimneys. Masonry chimneys exposed to the outdoors on one or more sides below the roof line.

3.3.18.2 Factory-Built Chimney. A chimney composed of listed factory-built components assembled in accordance with the manufacturer's installation instructions to form the completed chimney.

3.3.18.3 Masonry Chimney. A field-constructed chimney of solid masonry units, bricks, stones, listed masonry chimney units, or reinforced Portland cement concrete, lined with suitable chimney flue liners.

3.3.18.4 Metal Chimney. A field-constructed chimney of metal.

3.3.19 Clothes Dryer. An appliance used to dry wet laundry by means of heat.

- 3.3.19.1 Type 1 Clothes Dryer.** Primarily used in family living environment. May or may not be coin-operated for public use.
- 3.3.19.2 Type 2 Clothes Dryer.** Used in business with direct intercourse of the function with the public. May or may not be operated by public or hired attendant. May or may not be coin-operated.
- 3.3.20 Combustion.** A chemical process of oxidation that occurs at a rate fast enough to produce heat and usually light in the form of either a glow or flame. [5000, 2015]
- 3.3.21 Combustion Chamber.** The portion of an appliance within which combustion occurs.
- 3.3.22 Combustion Products.** Constituents resulting from the combustion of a fuel with the oxygen of the air, including the inert but excluding excess air.
- 3.3.23 Condensate (Condensation).** The liquid that separates from a gas (including flue gas) due to a reduction in temperature or an increase in pressure.
- 3.3.24 Controls.** Devices designed to regulate the gas, air, water, or electrical supply to an appliance, either manually or automatically.
- 3.3.24.1 Limit Control.** A device responsive to changes in pressure, temperature, or liquid level for turning on, shutting off, or throttling the gas supply to an appliance.
- 3.3.25 Copper Alloy.** A homogenous mixture of two or more metals in which copper is the primary component, such as brass and bronze.
- 3.3.26 Cubic Foot (ft³) of Gas.** The amount of gas that would occupy 1 ft³ (0.03 m³) when at a temperature of 60°F (16°C), saturated with water vapor and under a pressure equivalent to that of 30 in. w.c. (7.5 kPa).
- 3.3.27 Deep Fat Fryer.** See 3.3.5.5.3, Gas Deep Fat Fryer.
- 3.3.28 Device.**
- 3.3.28.1 Automatic Gas Shutoff Device.** A device constructed so that the attainment of a water temperature in a hot water supply system in excess of some predetermined limit acts in such a way as to cause the gas to the system to be shut off.
- 3.3.28.2 Pressure Limiting Device.** Equipment that under abnormal conditions will act to reduce, restrict, or shut off the supply of gas flowing into a system in order to prevent the gas pressure in that system from exceeding a predetermined value.
- 3.3.28.3 Quick-Disconnect Device.** A hand-operated device that provides a means for connecting and disconnecting an appliance or an appliance connector to a gas supply and that is equipped with an automatic means to shut off the gas supply when the device is disconnected.
- 3.3.28.4 Safety Shutoff Device.** A device that will shut off the gas supply to the controlled burner(s) in the event the source of ignition fails. This device can interrupt the flow of gas to main burner(s) only or to pilot(s) and main burner(s) under its supervision.
- 3.3.29 Diversity Factor.** Ratio of the maximum probable demand to the maximum possible demand.
- 3.3.30 Draft.** A pressure difference that causes gases or air to flow through a chimney, vent, flue, or appliance.
- 3.3.30.1 Mechanical Draft.** Draft produced by a fan or an air or steam jet. When a fan is located so as to push the flue gases through the chimney or vent, the draft is forced. When the fan is located so as to pull the flue gases through the chimney or vent, the draft is induced.
- 3.3.30.2 Natural Draft.** Draft produced by the difference in the weight of a column of flue gases within a chimney or vent system and a corresponding column of air of equal dimension outside the chimney or venting system. [31, 2016]
- 3.3.31 Draft Hood.** A nonadjustable device built into an appliance, or made a part of the vent connector from an appliance, that is designed to (1) provide for the ready escape of the flue gases from the appliance in the event of no draft, back-draft, or stoppage beyond the draft hood, (2) prevent a back-draft from entering the appliance, and (3) neutralize the effect of stack action of the chimney or gas vent upon the operation of the appliance.
- 3.3.32 Drip.** The container placed at a low point in a system of piping to collect condensate and from which it may be removed.
- 3.3.33 Dry Gas.** A gas having a moisture and hydrocarbon dew point below any normal temperature to which the gas piping is exposed.
- 3.3.34 Effective Ground-Fault Current Path.** An intentionally constructed, low impedance electrically conductive path designed and intended to carry current under ground-fault conditions from the point of a ground fault on a wiring system to the electrical supply source and that facilitates the operation of the overcurrent protective device or ground-fault detectors. [70:100]
- 3.3.35 Equipment.** Devices other than appliances.
- 3.3.36 Explosion Heads (Soft Heads or Rupture Discs).** A protective device for relieving excessive pressure in a premix system by bursting of a rupturable disc.
- 3.3.37 FAN Max.** The maximum input rating of a Category I, fan-assisted appliance attached to a vent or connector.
- 3.3.38 FAN Min.** The minimum input rating of a Category I, fan-assisted appliance attached to a vent or connector.
- 3.3.39 FAN+FAN.** The maximum combined appliance input rating of two or more Category I, fan-assisted appliances attached to the common vent.
- 3.3.40 FAN+NAT.** The maximum combined appliance input rating of one or more Category I, fan-assisted appliances and one or more Category I, draft hood-equipped appliances attached to the common vent.
- 3.3.41 Fireplace.** A fire chamber and hearth constructed of noncombustible material for use with solid fuels and provided with a chimney.
- 3.3.41.1 Gas Fireplace.**
- 3.3.41.1.1 Direct Vent Gas Fireplace.** A system consisting of (1) an appliance for indoor installation that allows the view of flames and provides the simulation of a solid fuel fireplace, (2) combustion air connections between the appli-

ance and the vent air intake terminal, (3) flue-gas connections between the appliance and the vent-air intake terminal, and (4) a vent air intake terminal for installation outdoors, constructed such that all air for combustion is obtained from the outdoor atmosphere and all flue gases are discharged to the outdoor atmosphere.

3.3.41.1.2 Vented Gas Fireplace. A vented appliance that allows the view of flames and provides the simulation of a solid fuel fireplace.

3.3.42 Flame Arrester. A nonvalve device for use in a gas-air mixture line containing a means for temporarily stopping the progress of a flame front (flashback).

3.3.43 Flue.

3.3.43.1 Appliance Flue. The passage(s) within an appliance through which combustion products pass from the combustion chamber of the appliance to the draft hood inlet opening on an appliance equipped with a draft hood or to the outlet of the appliance on an appliance not equipped with a draft hood.

3.3.43.2 Chimney Flue. The passage(s) in a chimney for conveying the flue or vent gases to the outdoors.

3.3.44 Flue Collar. That portion of an appliance designed for the attachment of a draft hood, vent connector, or venting system.

3.3.45 Furnace.

3.3.45.1 Central Furnace. A self-contained appliance for heating air by transfer of heat of combustion through metal to the air and designed to supply heated air through ducts to spaces remote from or adjacent to the appliance location.

3.3.45.2 Direct Vent Wall Furnace. A system consisting of an appliance, combustion air, and flue gas connections between the appliance and the outdoor atmosphere, and a vent cap supplied by the manufacturer and constructed so that all air for combustion is obtained from the outdoor atmosphere and all flue gases are discharged to the outdoor atmosphere.

3.3.45.3 Duct Furnace. A furnace normally installed in distribution ducts of air-conditioning systems to supply warm air for heating. This definition applies only to an appliance that, for air circulation, depends on a blower not furnished as part of the furnace.

3.3.45.4 Enclosed Furnace. A specific heating, or heating and ventilating, furnace incorporating an integral total enclosure and using only outdoor air for combustion.

3.3.45.5 Floor Furnace. A completely self-contained unit furnace suspended from the floor of the space being heated, taking air for combustion from outside this space.

3.3.45.6 Forced-Air Furnace. A furnace equipped with a fan or blower that provides the primary means for circulation of air.

3.3.45.7 Vented Wall Furnace. A self-contained, vented, fuel gas-burning appliance complete with grilles or equivalent, designed for incorporation in or permanent attachment to the structure of a building and furnishing heated air, circulated by gravity or by a fan, directly into the space to be heated through openings in the casing.

3.3.46 Furnace Plenum. A compartment or chamber that is supplied with the furnace or constructed of ductwork that is attached to the inlet or outlet of a furnace or air-handling unit and has one or more circulating air ducts connected to it.

3.3.47 Garage.

3.3.47.1 Repair Garage. A building, structure, or portions thereof wherein major repair, painting, or body and fender work is performed on motorized vehicles or automobiles, and includes associated floor space used for offices, parking, and showrooms.

3.3.47.2 Residential Garage. A building or room in which self-propelled passenger vehicles are or can be stored and that will not normally be used for other than minor service or repair operations on such stored vehicles.

▲ 3.3.48 Gas Convenience Outlet. A permanently mounted, hand-operated device providing a means for connecting and disconnecting an appliance or an appliance connector to the gas supply piping.

3.3.49 Gases. Include natural gas, manufactured gas, liquefied petroleum (LP) gas in the vapor phase only, liquefied petroleum gas-air mixtures, and mixtures of these gases, plus gas-air mixtures within the flammable range, with the fuel gas or the flammable component of a mixture being a commercially distributed product.

3.3.49.1 Flue Gases. Products of combustion plus excess air in appliance flues or heat exchangers.

3.3.49.2 Utility Gases. Natural gas, manufactured gas, liquefied petroleum gas-air mixtures, or mixtures of any of these gases.

3.3.49.3 Vent Gases. Products of combustion from appliances plus excess air, plus dilution air in the venting system above the draft hood or draft regulator.

3.3.50 Gas-Fired Air Conditioner. An automatically operated appliance for supplying cooled and/or dehumidified air or chilled liquid.

3.3.51 Gas-Fired Heat Pump. An automatically operated appliance utilizing a refrigeration system for supplying either heated air or liquid or heated and/or cooled air or liquid.

3.3.52 Gas-Mixing Machine. Any combination of automatic proportioning control devices, blowers, or compressors that supply mixtures of gas and air to multiple burner installations where control devices or other accessories are installed between the mixing device and burner.

3.3.53* Gas Vent. A passageway composed of listed factory-built components assembled in accordance with the manufacturer's installation instructions for conveying vent gases from appliances or their vent connectors to the outdoors.

3.3.53.1 Common Vent. That portion of a vent or chimney system that conveys vent gases from more than one appliance.

3.3.53.2 Special-Type Gas Vent. Gas vents for venting listed Category II, III, and IV appliances.

3.3.53.3 Type B Gas Vent. A gas vent for venting listed gas appliances with draft hoods and other Category I appliances listed for use with Type B gas vents.

3.3.53.4 Type B-W Gas Vent. A gas vent for venting listed wall furnaces.

3.3.53.5 Type L Gas Vent. A gas vent for venting appliances listed for use with Type L vents and appliances listed for use with Type B gas vents.

3.3.54 Gravity. See 3.3.91, Specific Gravity.

3.3.55 Grounding Electrode. A conducting object through which a direct connection to earth is established. [70:100]

3.3.56 Heater.

3.3.56.1 Direct Gas-Fired Nonrecirculating Industrial Air Heater. A nonrecirculating industrial air heater in which all the products of combustion generated by the appliance are released into the outdoor airstream being heated.

3.3.56.2 Direct Gas-Fired Recirculating Industrial Air Heater. An air recirculating heater in which all of the products of combustion generated by the appliance are released into the airstream being heated.

3.3.56.3 Infrared Heater. A heater that directs a substantial amount of its energy output in the form of infrared energy into the area to be heated. Such heaters may be of either the vented or unvented type.

3.3.56.4 Pool Heater. An appliance designed for heating nonpotable water stored at atmospheric pressure, such as water in swimming pools, therapeutic pools, and similar applications.

3.3.56.5 Unit Heater. A self-contained, automatically controlled, vented, fuel gas-burning, space-heating appliance intended for installation in the space to be heated without the use of ducts, having integral means for circulation of air.

3.3.56.6 Unvented Room Heater. An unvented, self-contained, freestanding, nonrecessed, fuel gas-burning appliance for furnishing warm air by gravity or fan circulation to the space in which installed, directly from the heater without duct connection.

3.3.56.7 Water Heater. An appliance for supplying hot water for domestic or commercial purposes.

3.3.57 Heating Value (Total). The number of British thermal units produced by the combustion, at constant pressure, of 1 ft³ (0.03 m³) of gas when the products of combustion are cooled to the initial temperature of the gas and air, when the water vapor formed during combustion is condensed, and when all the necessary corrections have been applied.

3.3.58 Hot Plate. See 3.3.5.5.2, Gas Counter Appliance.

3.3.58.1 Domestic Hot Plate. A fuel gas-burning appliance consisting of one or more open-top-type burners mounted on short legs or a base.

3.3.59 Ignition.

3.3.59.1 Automatic Ignition. Ignition of gas at the burner(s) when the gas-controlling device is turned on, including re-ignition if the flames on the burner(s) have been extinguished by means other than by the closing of the gas-controlling device.

3.3.59.2 Sources of Ignition. Appliances or equipment that, because of their intended modes of use or operation, are capable of providing sufficient thermal energy to ignite flammable gas-air mixtures.

3.3.60 Insulating Millboard. A factory-fabricated board formed with noncombustible materials, normally fibers, and having a thermal conductivity in the range of 1 Btu/in./ft²/°F/hr (0.14 W/m/°K).

3.3.61 Kettle. See 3.3.5.5.7.

3.3.62 Manifold.

3.3.62.1 Common Vent Manifold. A horizontal extension of the common vent within the room in which the appliances are installed.

3.3.62.2 Gas Manifold. The conduit of an appliance that supplies gas to the individual burners.

3.3.63 Manufactured Home. A structure, transportable in one or more sections, that, in the traveling mode, is 8 body-ft (2.4 m) or more in width or 40 body-ft (12.2 m) or more in length or, that on site is 320 ft² (29.7 m²) or more, is built on a permanent chassis, is designed to be used as a dwelling with or without a permanent foundation, whether or not connected to the utilities, and includes plumbing, heating, air-conditioning, and electrical systems contained therein. Such terms shall include any structure that meets all the requirements of this paragraph except the size requirements and with respect to which the manufacturer voluntarily files a certification required by the regulatory agency. Calculations used to determine the number of square feet in a structure are based on the structure's exterior dimensions, include all expandable rooms, cabinets, and other projections containing interior space, but do not include bay windows. [501, 2017]

3.3.64 Material.

3.3.64.1* Combustible (Material). A material that, in the form in which it is used and under the conditions anticipated, will ignite and burn; a material that does not meet the definition of noncombustible. [101, 2015].

3.3.64.2 Noncombustible Material. A material that, in the form in which it is used and under the conditions anticipated, will not ignite, burn, support combustion, or release flammable vapors when subjected to fire or heat.

3.3.65 Meter. An instrument installed to measure the volume of gas delivered through it.

▲ 3.3.66 Mixing Blower. A motor-driven blower to produce gas-air mixtures for combustion.

3.3.67 NA. Vent configuration that is not allowed due to potential for condensate formation or pressurization of the venting system or that is not applicable due to physical or geometric restraints.

3.3.68 NAT Max. The maximum input rating of a Category I, draft hood-equipped appliance attached to a vent or connector.

3.3.69 NAT+NAT. The maximum combined appliance input rating of two or more Category I, draft hood-equipped appliances attached to the common vent.

3.3.70 Occupancy.

3.3.70.1 Health Care Occupancy. An occupancy used to provide medical or other treatment or care simultaneously to four or more patients on an inpatient basis, where such patients are mostly incapable of self-preservation due to age, physical or mental disability, or because of security measures not under the occupants' control. [5000, 2015]

3.3.70.2 Residential Board and Care Occupancy. An occupancy used for lodging and boarding of four or more residents, not related by blood or marriage to the owners or operators, for the purpose of providing personal care services. [5000, 2015]

3.3.71 Orifice. The opening in a cap, spud, or other device whereby the flow of gas is limited and through which the gas is discharged to the burner.

3.3.72 Oven, Gas Baking and Roasting. See 3.3.5.5.1, Baking and Roasting Gas Oven.

3.3.73 Parking Structure. A building, structure, or portion thereof used for the parking, storage, or both, of motor vehicles. [88A, 2015]

3.3.73.1 Basement or Underground Parking Structure. A parking structure or portion thereof located below finished ground level.

3.3.73.2 Enclosed Parking Structure. Having exterior enclosing walls that have less than 25 percent of the total wall area open to atmosphere at each level using at least two sides of the structure.

3.3.74 Pilot. A small flame that is utilized to ignite the gas at the main burner or burners.

3.3.75 Pipe. Rigid conduit used to convey fuel gas or other fluids.

3.3.75.1 Equivalent Length Pipe. The resistance of valves, controls, and fittings to gas flow expressed as equivalent length of straight pipe for convenience in calculating pipe sizes.

3.3.76 Piping. Pipe or tubing.

3.3.76.1 Concealed Gas Piping. Gas piping that, when in place in a finished building, would require removal of permanent construction to gain access to the piping.

3.3.76.2 Control Piping. All piping, valves, and fittings used to interconnect air, gas, or hydraulically operated control apparatus or instrument transmitters and receivers.

3.3.77 Plenum. A compartment or chamber to which one or more ducts are connected and that forms part of the air distribution system. [90A, 2015]

3.3.78 Pressure. Unless otherwise stated, a measurement expressed in pounds per square inch above atmospheric pressure.

3.3.78.1 Atmospheric Pressure. The pressure of the weight of air on the surface of the earth, approximately 14.7 pounds per square inch (psia) (101 kPa absolute) at sea level.

3.3.78.2 Back Pressure. Pressure against which a fluid is flowing, resulting from friction in lines, restrictions in pipes or valves, pressure in vessel to which fluid is flowing, hydro-

static head, or other impediment that causes resistance to fluid flow.

3.3.78.3 Design Pressure. The maximum operating pressure permitted by this code, as determined by the design procedures applicable to the materials involved.

3.3.78.4 Maximum Working Pressure. The maximum pressure at which a piping system can be operated in accordance with the provisions of this code.

3.3.79 Pressure Drop. The loss in pressure due to friction or obstruction in pipes, valves, fittings, regulators, and burners.

3.3.80 Purge. To free a gas conduit of air or gas, or a mixture of gas and air.

3.3.81 Qualified Agency. Any individual, firm, corporation, or company that either in person or through a representative is engaged in and is responsible for (1) the installation, testing, or replacement of gas piping or (2) the connection, installation, testing, repair, or servicing of appliances and equipment; that is experienced in such work; that is familiar with all precautions required; and that has complied with all the requirements of the authority having jurisdiction.

3.3.82 Range. See 3.3.5.5.4, Gas Range.

3.3.83 Refrigerator (Using Gas Fuel). An appliance that is designed to extract heat from a suitable chamber.

3.3.84 Regulator.

3.3.84.1 Draft Regulator. A device that functions to maintain a desired draft in the appliance by automatically reducing the draft to the desired value.

3.3.84.1.1 Barometric Draft Regulator. A balanced damper device attached to a chimney, vent connector, breeching, or flue gas manifold to control chimney draft.

3.3.84.2 Gas Appliance Pressure Regulator. A pressure regulator for controlling pressure to the appliance manifold.

3.3.84.3 Line Pressure Regulator. A pressure regulator placed in a gas line between the service regulator and the appliance regulator.

3.3.84.4* Monitor Regulator. A pressure regulator that is installed in series with another pressure regulator for the purpose of preventing an overpressure in the downstream piping system.

3.3.84.5 Pressure Regulator. Equipment placed in a gas line for reducing, controlling, and maintaining the pressure in that portion of the piping system downstream of the equipment.

N 3.3.84.6 Regulator Vent. The opening in the atmospheric side of the regulator housing permitting the in and out movement of air to compensate for the movement of the regulator diaphragm.

3.3.84.7 Series Regulator. A pressure regulator in series with one or more other pressure regulators.

3.3.84.8 Service Regulator. A pressure regulator installed by the serving gas supplier to reduce and limit the service line gas pressure to delivery pressure.

3.3.85 Relief Opening. The opening provided in a draft hood to permit the ready escape to the atmosphere of the flue prod-

ucts from the draft hood in the event of no draft, backdraft, or stoppage beyond the draft hood and to permit inspiration of air into the draft hood in the event of a strong chimney updraft.

▲ **3.3.86 Safety Blowout (Backfire Preventer).** A protective device incorporating a bursting disc for excessive pressure release, means for stopping a flame front, and an electric switch or other release mechanism for actuating a built-in or separate safety shutoff.

3.3.87 Service Head Adapter. A transition fitting for use with plastic piping (which is encased in non-pressure-carrying metal pipe) that connects the metal pipe casing and plastic pipe and tubing to the remainder of the piping system.

3.3.88 Service Meter Assembly. The piping and fittings installed by the serving gas supplier to connect the inlet side of the meter to the gas service and to connect the outlet side of the meter to the customer's house or yard piping.

3.3.89 Service Regulator. See 3.3.84.5, Pressure Regulator; and 3.3.84.7, Service Regulator.

3.3.90 Shutoff. See 3.3.99, Valve.

3.3.91 Specific Gravity. As applied to gas, the ratio of the weight of a given volume to that of the same volume of air, both measured under the same conditions.

3.3.92 Steam Cooker. See 3.3.5.5.5, Gas Steam Cooker.

3.3.93 Steam Generator. See 3.3.5.5.6, Gas Steam Generator.

3.3.94 Stress. The resultant internal force that resists change in the size or shape of a body acted on by external forces. In this code, the term *stress* is often used as being synonymous with unit stress, which is the stress per unit area (psi).

3.3.94.1 Hoop Stress. The stress in a pipe wall, acting circumferentially in a plane perpendicular to the longitudinal axis of the pipe and produced by the pressure of the fluid in the pipe.

3.3.95 System.

3.3.95.1 Central Premix System. A system that distributes flammable gas-air mixtures to two or more remote stations.

3.3.95.2 Fan-Assisted Combustion System. An appliance equipped with an integral mechanical means to either draw or force products of combustion through the combustion chamber or heat exchanger.

3.3.95.3 Hybrid Pressure System. A piping system in which the pressure at the point of delivery is reduced by one or more line pressure regulators prior to the appliance connection.

3.3.95.4 Mechanical Exhaust System. Equipment installed in and made a part of the vent to provide the required flow of gases through the vent.

3.3.95.5 Natural Draft Venting System. A venting system that relies on natural draft to convey the products of combustion.

3.3.95.6 Piping System. All pipe, tubing, valves, and fittings from the point of delivery to the outlets of the appliance shutoff valves.

3.3.95.7* Venting System. A continuous open passageway from the flue collar or draft hood of an appliance to the outdoors for the purpose of removing flue or vent gases.

3.3.95.7.1 Forced Mechanical Draft Venting System. A venting system in which a fan or other mechanical device is used to cause the flow of flue or vent gases under positive vent pressure.

3.3.95.7.2 Mechanical Draft Venting System. A venting system designed to remove flue or vent gases by mechanical means, which can consist of an induced draft portion under nonpositive static pressure or a forced draft portion under positive static pressure.

3.3.96 Tensile Strength. The highest unit tensile stress (referred to the original cross section) a material can sustain before failure (psi).

3.3.97 Thread Joint Compounds. Nonhardening materials used on pipe threads to ensure a seal.

3.3.98 Tubing. Semirigid conduit of copper, steel, aluminum, corrugated stainless steel tubing (CSST), or plastic.

3.3.99 Valve. A device used in piping to control the gas supply to any section of a system of piping or to an appliance.

3.3.99.1 Appliance Shutoff Valve. A valve located in the piping system used to shut off individual equipment.

3.3.99.2 Automatic Valve. An automatic or semiautomatic device consisting essentially of a valve and operator that control the gas supply to the burner(s) during operation of an appliance.

3.3.99.3 Excess Flow Valve (EFV). A valve designed to activate when the fuel gas passing through it exceeds a prescribed flow rate.

3.3.99.4 Manual Reset Valve. An automatic shutoff valve installed in the gas supply piping and set to shut off when unsafe conditions occur. The device remains closed until manually reopened.

3.3.99.5 Relief Valve. A safety valve designed to forestall the development of a dangerous condition by relieving either pressure, temperature, or vacuum in a hot water supply system.

3.3.99.5.1 Pressure Relief Valve. A valve that automatically opens and closes a relief vent, depending on whether the pressure is above or below a predetermined value.

3.3.99.5.2 Temperature Relief Valve. A valve that automatically opens and automatically closes a relief vent, depending on whether the temperature is above or below a predetermined value.

3.3.99.5.3 Vacuum Relief Valve. A valve that automatically opens and closes a vent for relieving a vacuum within the hot water supply system, depending on whether the vacuum is above or below a predetermined value.

3.3.99.6 Service Shutoff Valve. A valve, installed by the serving gas supplier between the service meter or source of supply and the customer piping system, to shut off the entire piping system.

3.3.100 Valve Member. That part of a gas valve rotating within or in respect to the valve body that, by its position with respect to the valve body, controls the flow of gas.

3.3.100.1 Nondisplaceable Valve Member. A valve member that cannot be moved from its seat by a force applied to the handle or to any exterior portion of the valve.

3.3.101 Vent Connector. The pipe or duct that connects a fuel gas-burning appliance to a vent or chimney.

3.3.102 Vent Offset. An arrangement of two or more fittings and pipe installed for the purpose of locating a vertical section of vent pipe in a different but parallel plane with respect to an adjacent section of vertical vent pipe.

3.3.103 Venting. The conveyance of combustion products to the outdoors.

3.3.104 Wall Head Adapter. A transition fitting for terminating plastic pipe inside of buildings at the building wall.

3.3.105 Zero Governor. A regulating device that is normally adjusted to deliver gas at atmospheric pressure within its flow rating.

Chapter 4 General

4.1 Qualified Agency. Installation, testing, purging, and replacement of gas piping, appliances, or accessories, and repair and servicing of equipment, shall be performed only by a qualified agency.

4.2 Interruption of Service.

4.2.1 Notification of Interrupted Service. When the gas supply is to be turned off, it shall be the duty of the qualified agency to notify all affected users. Where two or more users are served from the same supply system, precautions shall be exercised to ensure that service only to the proper user is turned off.

Exception: In cases of emergency, affected users shall be notified as soon as possible of the actions taken by the qualified agency.

4.2.2 Work Interruptions. When interruptions in work occur while repairs or alterations are being made to an existing piping system, the system shall be left in a safe condition.

4.3 Prevention of Accidental Ignition.

4.3.1 Potential Ignition Sources. Where work is being performed on piping that contains or has contained gas, the following shall apply:

- (1) Provisions for electrical continuity shall be made before alterations are made in a metallic piping system.
- (2) Smoking, open flames, lanterns, welding, or other sources of ignition shall not be permitted.
- (3) A metallic electrical bond shall be installed around the location of cuts in metallic gas pipes made by other than cutting torches. Where cutting torches, welding, or other sources of ignition are to be used, it shall be determined that all sources of gas or gas-air mixtures have been secured and that all flammable gas or liquids have been cleared from the area. Piping shall be purged as required in Section 8.3 before welding or cutting with a torch is attempted.

- (4) Artificial illumination shall be restricted to listed safety-type flashlights and safety lamps. Electric switches shall not be turned on or turned off.

4.3.2 Handling of Flammable Liquids.

4.3.2.1 Drip Liquids. Liquid that is removed from a drip in existing gas piping shall be handled to avoid spillage or ignition. The gas supplier shall be notified when drip liquids are removed.

4.3.2.2 Other Flammable Liquids. Flammable liquids used by the installer shall be handled with precaution and shall not be left within the premises from the end of one working day to the beginning of the next.

4.4* Noncombustible Material. A material that complies with any of the following shall be considered a noncombustible material:

- (1) A material that, in the form in which it is used and under the conditions anticipated, will not ignite, burn, support combustion, or release flammable vapors when subjected to fire or heat
- (2) A material that is reported as passing ASTM E136, *Standard Test Method for Behavior of Materials in a Vertical Tube Furnace at 750°C*
- (3) A material that is reported as complying with the pass/fail criteria of ASTM E136 when tested in accordance with the test method and procedure in ASTM E2652, *Standard Test Method for Behavior of Materials in a Tube Furnace with a Cone-shaped Airflow Stabilizer, at 750°C*

Chapter 5 Gas Piping System Design, Materials, and Components

5.1 Piping Plan.

5.1.1 Installation of Piping System. Where required by the authority having jurisdiction, a piping sketch or plan shall be prepared before proceeding with the installation. The plan shall show the proposed location of piping, the size of different branches, the various load demands, and the location of the point of delivery.

5.1.2 Addition to Existing System. When additional appliances are being connected to a gas piping system, the existing piping shall be checked to determine whether it has adequate capacity. If the capacity of the system is determined to be inadequate for the additional appliances, the existing system shall be enlarged as required, or separate gas piping of adequate capacity shall be provided.

5.2 Provision for Location of Point of Delivery. The location of the point of delivery shall be acceptable to the serving gas supplier.

5.3 Interconnections Between Gas Piping Systems.

5.3.1 Interconnections Supplying Separate Users. Where two or more meters, or two or more service regulators where meters are not provided, are located on the same premises and supply separate users, the gas piping systems shall not be interconnected on the outlet side of the meters or service regulators.

5.3.2 Interconnections for Standby Fuels.

5.3.2.1 Where a supplementary gas for standby use is connected downstream from a meter or a service regulator where a meter is not provided, equipment to prevent backflow shall be installed.

5.3.2.2 A three-way valve installed to admit the standby supply and at the same time shut off the regular supply shall be permitted to be used for this purpose.

5.4 Sizing of Gas Piping Systems.

5.4.1* General Considerations. Gas piping systems shall be of such size and so installed as to provide a supply of gas sufficient to meet the maximum demand and supply gas to each appliance inlet at not less than the minimum supply pressure required by the appliance.

5.4.2* Maximum Gas Demand.

5.4.2.1* The volumetric flow rate of gas to be provided shall be the sum of the maximum input of the appliances served.

5.4.2.2 The volumetric flow rate of gas to be provided shall be adjusted for altitude where the installation is above 2,000 ft (609.6 m).

5.4.2.3 The total connected hourly load shall be used as the basis for piping sizing, assuming all appliances are operating at full capacity simultaneously.

Exception: Sizing shall be permitted to be based upon established load diversity factors.

Δ 5.4.3* Sizing Methods. Gas piping shall be sized in accordance with one of the following:

- (1) Pipe sizing tables or sizing equations in Chapter 6
- (2) Other approved engineering methods
- (3) Sizing tables included in a listed piping system manufacturer's installation instructions

5.4.4 Allowable Pressure Drop. The design pressure loss in any piping system under maximum probable flow conditions, from the point of delivery to the inlet connection of the appliance, shall be such that the supply pressure at the appliance is greater than or equal to the minimum pressure required by the appliance.

5.5 Operating Pressure.

Δ 5.5.1 Piping System Operating Pressure Limitations. The maximum operating pressure for any piping system shall not exceed 125 psi (862 kPa).

N 5.5.2 Flammable Gas–Air Mixtures. The maximum operating pressure for piping systems for gas–air mixtures within the flammable range shall be 10 psi (69 kPa).

N 5.5.3 LP-Gas Piping Systems. The maximum operating pressure for LP-Gas piping systems shall be 20 psi (140 kPa), except as provided in 5.5.4(7).

N 5.5.4 Maximum Operating Pressure in Buildings. The maximum operating pressure for any piping systems located inside buildings shall not exceed 5 psi (34 kPa) unless one or more of the following conditions are met:

- (1)* The piping joints are welded or brazed.
- (2) The piping joints are flanged and all pipe-to-flange connections are made by welding or brazing.

- (3) The piping is located in a ventilated chase or otherwise enclosed for protection against accidental gas accumulation.
- (4) The piping is located inside buildings or separate areas of buildings used exclusively for one of the following:
 - (a) Industrial processing or heating
 - (b) Research
 - (c) Warehousing
 - (d) Boiler or mechanical rooms
- (5) The piping is a temporary installation for buildings under construction.
- (6) The piping serves appliances or equipment used for agricultural purposes.
- (7) The piping system is an LP-Gas piping system with an operating pressure greater than 20 psi (138 kPa) and complies with NFPA 58.

5.5.5 LP-Gas Systems Operating Below -5°F (-21°C). LP-Gas systems designed to operate below -5°F (-21°C) or with butane or a propane-butane mix shall be designed to either accommodate liquid LP-Gas or to prevent LP-Gas vapor from condensing back into a liquid.

5.6* Acceptable Piping Materials and Joining Methods.

5.6.1 General.

5.6.1.1 Acceptable Materials. Materials used for piping systems shall either comply with the requirements of this chapter or be acceptable to the authority having jurisdiction.

5.6.1.2 Used Materials. Pipe, fittings, valves, or other materials shall not be used again unless they are free of foreign materials and have been ascertained to be adequate for the service intended.

5.6.1.3 Other Materials. Material not covered by the standards specifications listed herein shall meet the following criteria:

- (1) Be investigated and tested to determine that it is safe and suitable for the proposed service
- (2) Be recommended for that service by the manufacturer
- (3) Be acceptable to the authority having jurisdiction

5.6.2 Metallic Pipe.

5.6.2.1 Cast Iron. Cast-iron pipe shall not be used.

Δ 5.6.2.2 Steel, Stainless Steel, and Wrought Iron. Steel, stainless steel, and wrought-iron pipe shall be at least Schedule 10 and shall comply with the dimensional standards of ANSI/ASME B36.10M, *Welded and Seamless Wrought Steel Pipe*, and one of the following:

- (1) ASTM A53, *Standard Specification for Pipe, Steel, Black and Hot-Dipped, Zinc-Coated Welded and Seamless*
- (2) ASTM A106, *Standard Specification for Seamless Carbon Steel Pipe for High-Temperature Service*
- (3) ASTM A312, *Standard Specification for Seamless, Welded, and Heavily Cold Worked Austenitic Stainless Steel Pipes*

5.6.2.3* Copper and Copper Alloy. Copper and copper alloy pipe shall not be used if the gas contains more than an average of 0.3 grains of hydrogen sulfide per 100 scf of gas (0.7 mg/100 L).

5.6.2.4 Threaded Copper, Copper Alloy, and Aluminum. Threaded copper, copper alloy, or aluminum alloy pipe shall not be used with gases corrosive to such material.

5.6.2.5 Aluminum Alloy. Aluminum alloy pipe shall comply with ASTM B241, *Standard Specification for Aluminum and Aluminum-Alloy Seamless Pipe and Seamless Extruded Tube* (except that the use of alloy 5456 is prohibited), and shall be marked at each end of each length indicating compliance. Aluminum alloy pipe shall be coated to protect against external corrosion where it is in contact with masonry, plaster, or insulation or is subject to repeated wettings by such liquids as water, detergents, or sewage.

5.6.2.6 Aluminum Installation. Aluminum alloy pipe shall not be used in exterior locations or underground.

5.6.3 Metallic Tubing.

N 5.6.3.1 Tubing shall not be used with gases corrosive to the tubing material

5.6.3.2 Steel. Steel tubing shall comply with ASTM A254, *Standard Specification for Copper-Brazed Steel Tubing*.

N 5.6.3.3 Stainless Steel. Stainless steel tubing shall comply with one of the following:

- (1) ASTM A268, *Standard Specification for Seamless and Welded Ferritic and Martensitic Stainless Steel Tubing for General Service*
- (2) ASTM A269, *Standard Specification for Seamless and Welded Austenitic Stainless Steel Tubing for General Service*

5.6.3.4* Copper and Copper Alloy. Copper and copper alloy tubing shall not be used if the gas contains more than an average of 0.3 grains of hydrogen sulfide per 100 scf of gas (0.7 mg/100 L). Copper tubing shall comply with standard Type K or Type L of ASTM B88, *Standard Specification for Seamless Copper Water Tube*, or ASTM B280, *Standard Specification for Seamless Copper Tube for Air Conditioning and Refrigeration Field Service*.

5.6.3.5 Aluminum. Aluminum alloy tubing shall comply with ASTM B210, *Standard Specification for Aluminum and Aluminum-Alloy Drawn Seamless Tubes*, or ASTM B241, *Standard Specification for Aluminum and Aluminum-Alloy Seamless Pipe and Seamless Extruded Tube*. Aluminum alloy tubing shall be coated to protect against external corrosion where it is in contact with masonry, plaster, or insulation or is subject to repeated wettings by such liquids as water, detergent, or sewage. Aluminum alloy tubing shall not be used in exterior locations or underground.

5.6.3.6 Corrugated Stainless Steel. Corrugated stainless steel tubing shall be listed in accordance with ANSI LC 1/GSA 6.26, *Fuel Gas Piping Systems Using Corrugated Stainless Steel Tubing*.

5.6.4 Plastic Pipe, Tubing, and Fittings.

5.6.4.1 Standard and Marking.

5.6.4.1.1 Polyethylene plastic pipe, tubing, and fittings used to supply fuel gas shall conform to ASTM D2513, *Standard Specification for Polyethylene (PE) Gas Pressure Pipe, Tubing, and Fittings*. Pipe to be used shall be marked “gas” and “ASTM D2513.”

Δ 5.6.4.1.2 Polyamide pipe, tubing, and fittings shall be identified in and conform to ASTM F2945, *Standard Specification for Polyamide 11 Gas Pressure Pipe, Tubing, and Fittings*. Pipe to be used shall be marked “gas” and “ASTM F2945.”

5.6.4.1.3 Polyvinyl chloride (PVC) and chlorinated polyvinyl chloride (CPVC) plastic pipe, tubing, and fittings shall not be used to supply fuel gas.

5.6.4.2* Regulator Vent Piping. Plastic pipe and fittings used to connect regulator vents to remote vent terminations shall be PVC conforming to ANSI/UL 651, *Schedule 40 and 80 Rigid PVC Conduit and Fittings*. PVC vent piping shall not be installed indoors.

Δ 5.6.4.3 Anodeless Risers. Anodeless risers shall comply with the following:

- (1) Factory-assembled anodeless risers shall be recommended by the manufacturer for the gas used and shall be leak tested by the manufacturer in accordance with written procedures.
- (2) Service head adapters and field-assembled anodeless risers incorporating service head adapters shall be recommended by the manufacturer for the gas used and shall be design-certified to meet the requirements of Category I of ASTM D2513, *Standard Specification for Polyethylene (PE) Gas Pressure Pipe, Tubing, and Fittings*, and 49 CFR 192.281(e). The manufacturer shall provide the user qualified installation instructions as prescribed by 49 CFR 192.283(b).
- (3) The use of plastic pipe, tubing, and fittings in undiluted LP-Gas piping systems shall be in accordance with NFPA 58.

5.6.5 Workmanship and Defects. Gas pipe, tubing, and fittings shall be clear and free from cutting burrs and defects in structure or threading and shall be thoroughly brushed and chip and scale blown. Defects in pipe, tubing, and fittings shall not be repaired. Defective pipe, tubing, and fittings shall be replaced.

5.6.6 Metallic Pipe Threads.

5.6.6.1 Specifications for Pipe Threads. Metallic pipe and fitting threads shall be taper pipe threads and shall comply with ANSI/ASME B1.20.1, *Pipe Threads, General Purpose, Inch*.

5.6.6.2 Damaged Threads. Pipe with threads that are stripped, chipped, corroded, or otherwise damaged shall not be used. Where a weld opens during the operation of cutting or threading, that portion of the pipe shall not be used.

5.6.6.3 Number of Threads. Field threading of metallic pipe shall be in accordance with Table 5.6.6.3.

5.6.6.4* Thread Joint Compounds. Thread joint compounds shall be resistant to the action of LP-Gas or to any other chemi-

Δ Table 5.6.6.3 Specifications for Threading Metallic Pipe

| Iron Pipe Size (in.) | Approximate Length of Threaded Portion (in.) | Approximate No. of Threads to Be Cut |
|----------------------|----------------------------------------------|--------------------------------------|
| ½ | ¾ | 10 |
| ¾ | ¾ | 10 |
| 1 | 7/8 | 10 |
| 1¼ | 1 | 11 |
| 1½ | 1 | 11 |
| 2 | 1 | 11 |
| 2½ | 1½ | 12 |
| 3 | 1½ | 12 |
| 4 | 1¾ | 13 |

For SI units, 1 in. = 25.4 mm.

cal constituents of the gases to be conducted through the piping.

5.6.7 Metallic Piping Joints and Fittings. The type of piping joint used shall be suitable for the pressure and temperature conditions and shall be selected giving consideration to joint tightness and mechanical strength under the service conditions. The joint shall be able to sustain the maximum end force due to the internal pressure and any additional forces due to temperature expansion or contraction, vibration, fatigue, or the weight of the pipe and its contents.

5.6.7.1* Pipe Joints. Schedule 40 and heavier pipe joints shall be threaded, flanged, brazed, welded, or assembled with press-connect fittings listed to ANSI LC 4/CSA 6.32, *Press-Connect Metallic Fittings for Use in Fuel Gas Distribution Systems*.

N (A) Pipe lighter than Schedule 40 shall be connected using press-connect fittings, flanges, brazing, or welding.

N (B) Where nonferrous pipe is brazed, the brazing materials shall have a melting point in excess of 1000°F (538°C).

N (C) Brazing alloys shall not contain more than 0.05 percent phosphorus.

5.6.7.2 Copper Tubing Joints. Copper tubing joints shall be assembled with approved gas tubing fittings, shall be brazed with a material having a melting point in excess of 1000°F (538°C), or shall be assembled with press-connect fittings listed to ANSI LC 4/CSA 6.32, *Press-Connect Metallic Fittings for Use in Fuel Gas Distribution Systems*. Brazing alloys shall not contain more than 0.05 percent phosphorus.

N 5.6.7.3 Stainless Steel Tubing Joints. Stainless steel joints shall be welded, assembled with approved tubing fittings, brazed with a material having a melting point in excess of 1000°F (538°C), or assembled with press-connect fittings listed to ANSI LC 4/CSA 6.32, *Press-Connect Metallic Fittings for Use in Fuel Gas Distribution Systems*. Brazing alloys and fluxes shall be recommended by the manufacturer for use on stainless steel alloys.

5.6.7.4 Flared Joints. Flared joints shall be used only in systems constructed from nonferrous pipe and tubing where experience or tests have demonstrated that the joint is suitable for the conditions and where provisions are made in the design to prevent separation of the joints.

Δ 5.6.7.5 Metallic Pipe Fittings. Metallic fittings shall comply with the following:

- (1) Threaded fittings in sizes larger than 4 in. (100 mm) shall not be used.
- (2) Fittings used with steel, stainless steel, or wrought-iron pipe shall be steel, stainless steel, copper alloy, malleable iron, or cast iron.
- (3) Fittings used with copper or copper alloy pipe shall be copper or copper alloy.
- (4) Fittings used with aluminum alloy pipe shall be aluminum alloy.
- (5) *Cast-Iron Fittings.* Cast-iron fittings shall comply with the following:
 - (a) Flanges shall be permitted.
 - (b) Bushings shall not be used.
 - (c) Fittings shall not be used in systems containing flammable gas-air mixtures.

(d) Fittings in sizes 4 in. (100 mm) and larger shall not be used indoors unless approved by the authority having jurisdiction.

(e) Fittings in sizes 6 in. (150 mm) and larger shall not be used unless approved by the authority having jurisdiction.

(6) *Aluminum Alloy Fittings.* Threads shall not form the joint seal.

(7) *Zinc-Aluminum Alloy Fittings.* Fittings shall not be used in systems containing flammable gas-air mixtures.

(8) *Special Fittings.* Fittings such as couplings, proprietary-type joints, saddle tees, gland-type compression fittings, and flared, flareless, or compression-type tubing fittings shall be as follows:

(a) Used within the fitting manufacturer's pressure-temperature recommendations

(b) Used within the service conditions anticipated with respect to vibration, fatigue, thermal expansion, or contraction

(c) Acceptable to the authority having jurisdiction

(9) When pipe fittings are drilled and tapped in the field, the operation shall be in accordance with the following:

(a) The operation shall be performed on systems having operating pressures of 5 psi (34 kPa) or less.

(b) The operation shall be performed by the gas supplier or their designated representative.

(c) The drilling and tapping operation shall be performed in accordance with written procedures prepared by the gas supplier.

(d) The fittings shall be located outdoors.

(e) The tapped fitting assembly shall be inspected and proven to be free of leaks.

Δ 5.6.8 Plastic Piping Joints and Fittings. Plastic pipe, tubing, and fittings shall be joined in accordance with the manufacturers' instructions. The following shall be observed when making such joints:

(1) The joint shall be designed and installed so that the longitudinal pullout resistance of the joint will be at least equal to the tensile strength of the plastic piping material.

(2) Heat fusion joints shall be made in accordance with qualified procedures that have been established and proven by test to produce gastight joints at least as strong as the pipe or tubing being joined. Joints shall be made with the joining method recommended by the pipe manufacturer. Heat fusion fittings shall be marked "ASTM D2513."

(3) Where compression-type mechanical joints are used, the gasket material in the fitting shall be compatible with the plastic piping and with the gas distributed by the system. An internal tubular rigid stiffener shall be used in conjunction with the fitting. The stiffener shall be flush with the end of the pipe or tubing and shall extend at least to the outside end of the compression fitting when installed. The stiffener shall be free of rough or sharp edges and shall not be a force fit in the plastic. Split tubular stiffeners shall not be used.

(4) Plastic piping joints and fittings for use in LP-Gas piping systems shall be in accordance with NFPA 58.

5.6.9 Flanges.

5.6.9.1 Flange Specifications.

5.6.9.1.1 Cast iron flanges shall be in accordance with ANSI/ASME B16.1, *Gray Iron Pipe Flanges and Flanged Fittings: Classes 25, 125, and 250*.

5.6.9.1.2 Steel flanges shall be in accordance with the following: ANSI/ASME B16.5, *Pipe Flanges and Flanged Fittings: NPS ½ through NPS 24 Metric/Inch Standard*, or ANSI/ASME B16.47, *Large Diameter Steel Flanges: NPS 26 through NPS 60 Metric/Inch Standard*.

5.6.9.1.3 Non-ferrous flanges shall be in accordance with ANSI/ASME B16.24, *Cast Copper Alloy Pipe Flanges and Flanged Fittings: Classes 150, 300, 600, 900, 1500, and 2500*.

5.6.9.1.4 Ductile iron flanges shall be in accordance with ANSI/ASME B16.42, *Ductile Iron Pipe Flanges and Flanged Fittings, Classes 150 and 300*.

5.6.9.2 Dissimilar Flange Connections. Raised-face flanges shall not be joined to flat-faced cast iron, ductile iron or non-ferrous material flanges.

5.6.9.3 Flange Facings. Standard facings shall be permitted for use under this code. Where 150 psi (1034 kPa) steel flanges are bolted to Class 125 cast-iron flanges, the raised face on the steel flange shall be removed.

5.6.9.4 Lapped Flanges. Lapped flanges shall be used only aboveground or in exposed locations accessible for inspection.

5.6.10 Flange Gaskets. The material for gaskets shall be capable of withstanding the design temperature and pressure of the piping system and the chemical constituents of the gas being conducted without change to its chemical and physical properties. The effects of fire exposure to the joint shall be considered in choosing the material.

5.6.10.1 Acceptable materials shall include the following:

- (1) Metal (plain or corrugated)
- (2) Composition
- (3) Aluminum "O" rings
- (4) Spiral-wound metal gaskets
- (5) Rubber-faced phenolic
- (6) Elastomeric

5.6.10.2 Gasket Specifications.

5.6.10.2.1 Metallic flange gaskets shall be in accordance with ANSI/ASME B16.20, *Metallic Gaskets for Pipe Flanges: Ring-Joint, Spiral-Wound and Jacketed*.

5.6.10.2.2 Non-metallic flange gaskets shall be in accordance with ANSI/ASME B16.21, *Nonmetallic Flat Gaskets for Pipe Flanges*.

5.6.10.3 Full-face flange gaskets shall be used with all non-steel flanges.

5.6.10.4 When a flanged joint is separated, the gasket shall be replaced.

5.7* Gas Meters.

5.7.1 Capacity. Gas meters shall be selected for the maximum expected pressure and permissible pressure drop.

5.7.2 Location.

5.7.2.1 Gas meters shall be located in ventilated spaces readily accessible for examination, reading, replacement, or necessary maintenance.

5.7.2.2 Gas meters shall not be placed where they will be subjected to damage, such as adjacent to a driveway, under a fire escape, in public passages, halls, or where they will be subject to excessive corrosion or vibration.

5.7.2.3 Gas meters shall not be located where they will be subjected to extreme temperatures or sudden extreme changes in temperature or in areas where they are subjected to temperatures beyond those recommended by the manufacturer.

5.7.3 Supports. Gas meters shall be supported or connected to rigid piping so as not to exert a strain on the meters. Where flexible connectors are used to connect a gas meter to downstream piping at mobile homes in mobile home parks, the meter shall be supported by a post or bracket placed in a firm footing or by other means providing equivalent support.

5.7.4 Meter Protection. Meters shall be protected against overpressure, back pressure, and vacuum.

5.7.5 Identification. Gas piping at multiple meter installations shall be marked by a metal tag or other permanent means designating the building or the part of the building being supplied and attached by the installing agency.

5.8* Gas Pressure Regulators.

Δ 5.8.1 Where Required. A line pressure regulator shall be installed where the gas supply pressure exceeds the maximum allowable inlet pressure of the appliance served.

5.8.2 Listing. Line pressure regulators shall be listed in accordance with ANSI Z21.80/CSA 6.22, *Line Pressure Regulators*, where the outlet pressure is set to 2 psi or less.

5.8.3 Location. The gas pressure regulator shall be accessible for servicing.

5.8.4 Regulator Protection. Pressure regulators shall be protected against physical damage.

5.8.5 Venting.

5.8.5.1 Line Pressure Regulators. Line pressure regulators shall comply with all of the following:

- (1) An independent vent to the exterior of the building, sized in accordance with the regulator manufacturer's instructions, shall be provided where the location of a regulator is such that a ruptured diaphragm will cause a hazard.
 - (a) Where more than one regulator is at a location, each regulator shall have a separate vent to the outdoors or, if approved by the authority having jurisdiction, the vent lines shall be permitted to be manifolded in accordance with accepted engineering practices to minimize back pressure in the event of diaphragm failure.
 - (b) Materials for vent piping shall be in accordance with Section 5.6.

Exception: A regulator and vent limiting means combination listed as complying with ANSI Z21.80/CSA 6.22, Line Pressure

Regulators, shall be permitted to be used without a vent to the outdoors.

- (2) The vent shall be designed to prevent the entry of water, insects, or other foreign materials that could cause blockage.
- (3) The regulator vent shall terminate at least 3 ft (0.9 m) from a source of ignition.
- (4) At locations where regulators might be submerged during floods, a special antiflood-type breather vent fitting shall be installed, or the vent line shall be extended above the height of the expected flood waters.
- (5) A regulator shall not be vented to the appliance flue or exhaust system.

5.8.5.2 Gas Appliance Pressure Regulators. For venting of gas appliance pressure regulators, see 9.1.19.

5.8.6 Bypass Piping. Valved and regulated bypasses shall be permitted to be placed around gas line pressure regulators where continuity of service is imperative.

5.8.7 Identification. Line pressure regulators at multiple regulator installations shall be marked by a metal tag or other permanent means designating the building or the part of the building being supplied.

5.9 Overpressure Protection Devices.

5.9.1 Where Required. Where the serving gas supplier delivers gas at a pressure greater than 2 psi (14 kPa) for piping systems serving appliances designed to operate at a gas pressure of 14 in. w.c. (3.4 kPa) or less, overpressure protection devices shall be installed. Piping systems serving equipment designed to operate at inlet pressures greater than 14 in. w.c. (3.4 kPa) shall be equipped with overpressure protection devices as required by the appliance manufacturer's installation instructions.

5.9.2 Pressure Limitation Requirements.

5.9.2.1 Where piping systems serving appliances designed to operate with a gas supply pressure of 14 in. w.c. (3.4 kPa) or less are required to be equipped with overpressure protection by 5.9.1, each overpressure protection device shall be adjusted to limit the gas pressure to each connected appliance to 2 psi (14 kPa) or less upon a failure of the line pressure regulator.

5.9.2.2 Where piping systems serving appliances designed to operate with a gas supply pressure greater than 14 in. w.c. (3.4 kPa) are required to be equipped with overpressure protection by 5.9.1, each overpressure protection device shall be adjusted to limit the gas pressure to each connected appliance as required by the appliance manufacturer's installation instructions.

5.9.2.3 Each overpressure protection device installed to meet the requirements of this section shall be capable of limiting the pressure to its connected appliance(s) as required by this section independently of any other pressure control equipment in the piping system.

5.9.2.4 Each gas piping system for which an overpressure protection device is required by this section shall be designed and installed so that a failure of the primary pressure control device(s) is detectable.

5.9.2.5 If a pressure relief valve is used to meet the requirements of this section, it shall have a flow capacity such that the

pressure in the protected system is maintained at or below the limits specified in 5.9.2.1 under the following conditions:

- (1) The line pressure regulator for which the relief valve is providing overpressure protection has failed wide open.
- (2) The gas pressure at the inlet of the line pressure regulator for which the relief valve is providing overpressure protection is not less than the regulator's normal operating inlet pressure.

5.9.3 Overpressure Protection Devices.

5.9.3.1 Overpressure protection devices shall be one of the following:

- (1) Pressure relief valve.
- (2) Monitor regulator.
- (3) Series regulator installed upstream from the line regulator and set to continuously limit the pressure on the inlet of the line regulator to the maximum values specified by 5.9.2.1 or less.
- (4) Automatic shutoff device installed in series with the line pressure regulator and set to shut off when the pressure on the downstream piping system reaches the maximum values specified by 5.9.2.1 or less. This device shall be designed so that it will remain closed until manually reset.

5.9.3.2 The devices in 5.9.3.1 shall be installed either as an integral part of the service or line pressure regulator or as separate units. Where separate overpressure protection devices are installed, they shall comply with 5.9.4 through 5.9.9.

5.9.4 Construction and Installation. All overpressure protection devices shall meet the following requirements:

- (1) Be constructed of materials so that the operation of the device is not impaired by corrosion of external parts by the atmosphere or of internal parts by the gas.
- (2) Be designed and installed so they can be operated to determine whether the valve is free. The devices shall also be designed and installed so they can be tested to determine the pressure at which they operate and be examined for leakage when in the closed position.

5.9.5 External Control Piping. External control piping shall be designed and installed so that damage to the control piping of one device does not render both the regulator and the overpressure protective device inoperative.

5.9.6 Setting. Each pressure limiting or pressure relieving device shall be set so that the gas pressure supplied to the connected appliance(s) does not exceed the limits specified in 5.9.2.1 and 5.9.2.2.

5.9.7 Unauthorized Operation. Where unauthorized operation of any shutoff valve could render a pressure relieving valve or pressure limiting device inoperative, one of the following shall be accomplished:

- (1) The valve shall be locked in the open position. Instruct authorized personnel in the importance of leaving the shutoff valve open and of being present while the shutoff valve is closed so that it can be locked in the open position before leaving the premises.
- (2) Duplicate relief valves shall be installed, each having adequate capacity to protect the system, and arrange the isolating valves or three-way valve so that only one relief valve can be rendered inoperative at a time.

5.9.8 Vents.

5.9.8.1 The discharge stacks, vents, or outlet parts of all pressure relieving and pressure limiting devices shall be located so that gas is safely discharged to the outdoors. Discharge stacks or vents shall be designed to prevent the entry of water, insects, or other foreign material that could cause blockage.

5.9.8.2 The discharge stack or vent line shall be at least the same size as the outlet of the pressure relieving device.

5.9.9 Size of Fittings, Pipe, and Openings. The fittings, pipe, and openings located between the system to be protected and the pressure relieving device shall be sized to prevent hammering of the valve and to prevent impairment of relief capacity.

5.10 Back Pressure Protection.

5.10.1 Where to Install.

5.10.1.1 Protective devices shall be installed as close to the equipment as practical where the design of equipment connected is such that air, oxygen, or standby gases could be forced into the gas supply system.

5.10.1.2 Gas and air combustion mixers incorporating double diaphragm “zero” or “atmosphere” governors or regulators shall require no further protection unless connected directly to compressed air or oxygen at pressures of 5 psi (34 kPa) or more.

5.10.2 Protective Devices. Protective devices shall include but not be limited to the following:

- (1) Check valves
- (2) Three-way valves (of the type that completely closes one side before starting to open the other side)
- (3) Reverse flow indicators controlling positive shutoff valves
- (4) Normally closed air-actuated positive shutoff pressure regulators

5.11* Low-Pressure Protection. A protective device shall be installed between the meter and the appliance or equipment if the operation of the appliance or equipment is such that it could produce a vacuum or a dangerous reduction in gas pressure at the meter. Such protective devices include, but are not limited to, mechanical, diaphragm-operated, or electrically operated low-pressure shutoff valves.

5.12 Shutoff Valves. Shutoff valves shall be approved and shall be selected giving consideration to pressure drop, service involved, emergency use, and reliability of operation. Shutoff valves of size 1 in. (25 mm) National Pipe Thread and smaller shall be listed.

5.13 Excess Flow Valve(s). Where automatic excess flow valves are installed, they shall be listed to ANSI Z21.93/CSA 6.30, *Excess Flow Valves for Natural and LP-Gas with Pressures Up to 5 psig*, and shall be sized and installed in accordance with the manufacturers' instructions.

5.14 Expansion and Flexibility.

5.14.1 Design. Piping systems shall be designed to prevent failure from thermal expansion or contraction.

5.14.2 Special Local Conditions. Where local conditions include earthquake, tornado, unstable ground, or flood hazards, special consideration shall be given to increased strength and flexibility of piping supports and connections.

Chapter 6 Pipe Sizing

6.1* Pipe Sizing Methods. Where the pipe size is to be determined using any of the methods in 6.1.1 through 6.1.3, the diameter of each pipe segment shall be obtained from the pipe sizing tables in Section 6.2 or Section 6.3 or from the sizing equations in Section 6.4. For SI units, 1 ft³ = 0.028 m³, 1 ft = 0.305 m, 1 in. w.c. = 0.249 kPa, 1 psi = 6.894 kPa, 1000 Btu/hr = 0.293 kW.

6.1.1* Longest Length Method. The pipe size of each section of gas piping shall be determined using the longest length of piping from the point of delivery to the most remote outlet and the load of the section.

6.1.2* Branch Length Method. Pipe shall be sized as follows:

- (1) Pipe size of each section of the longest pipe run from the point of delivery to the most remote outlet shall be determined using the longest run of piping and the load of the section.
- (2) The pipe size of each section of branch piping not previously sized shall be determined using the length of piping from the point of delivery to the most remote outlet in each branch and the load of the section.

6.1.3 Hybrid Pressure. The pipe size for each section of higher pressure gas piping shall be determined using the longest length of piping from the point of delivery to the most remote line pressure regulator. The pipe size from the line pressure regulator to each outlet shall be determined using the length of piping from the regulator to the most remote outlet served by the regulator.

Δ 6.2 Sizing Natural Gas Piping Systems. Sizing of piping systems shall be in accordance with 6.2.1 or 6.2.2.

N 6.2.1 Table 6.2.1(a) through Table 6.2.1(x) shall be used in conjunction with one of the methods described in 6.1.1 through 6.1.3 for piping materials other than non-corrugated stainless steel tubing.

N 6.2.2 Section 6.4 shall be used in conjunction with one of the methods described in 6.1.1 through 6.1.3 for non-corrugated stainless steel tubing.

Δ 6.3 Sizing Propane Piping Systems. Sizing of piping systems shall be in accordance with 6.3.1 or 6.3.2.

N 6.3.1 Table 6.3.1(a) through Table 6.3.1(m) shall be used in conjunction with one of the methods described in 6.1.1 through 6.1.3 for piping materials other than non-corrugated stainless steel tubing.

N 6.3.2 Section 6.4 shall be used in conjunction with one of the methods described in 6.1.1 through 6.1.3 for non-corrugated stainless steel tubing.

6.4 Sizing Equations. The inside diameter of smooth wall pipe or tubing shall be determined by the sizing equations in 6.4.1 and 6.4.2 using the equivalent pipe length determined by the methods in 6.1.1 through 6.1.3.

Table 6.2.1(a) Schedule 40 Metallic Pipe

| | | | | | | | | | | | | | Gas: Natural | | | |
|-------------|----------------------------------------|-------|-------|-------|-------|-------|-------|-------|--------|--------|--------|---------|---------------------------------|---------|--|--|
| | | | | | | | | | | | | | Inlet Pressure: Less than 2 psi | | | |
| | | | | | | | | | | | | | Pressure Drop: 0.3 in. w.c. | | | |
| | | | | | | | | | | | | | Specific Gravity: 0.60 | | | |
| | | | | | | | | | | | | | Pipe Size (in.) | | | |
| Nominal: | ½ | ¾ | 1 | 1¼ | 1½ | 2 | 2½ | 3 | 4 | 5 | 6 | 8 | 10 | 12 | | |
| Actual ID: | 0.622 | 0.824 | 1.049 | 1.380 | 1.610 | 2.067 | 2.469 | 3.068 | 4.026 | 5.047 | 6.065 | 7.981 | 10.020 | 11.938 | | |
| Length (ft) | Capacity in Cubic Feet of Gas per Hour | | | | | | | | | | | | | | | |
| 10 | 131 | 273 | 514 | 1,060 | 1,580 | 3,050 | 4,860 | 8,580 | 17,500 | 31,700 | 51,300 | 105,000 | 191,000 | 303,000 | | |
| 20 | 90 | 188 | 353 | 726 | 1,090 | 2,090 | 3,340 | 5,900 | 12,000 | 21,800 | 35,300 | 72,400 | 132,000 | 208,000 | | |
| 30 | 72 | 151 | 284 | 583 | 873 | 1,680 | 2,680 | 4,740 | 9,660 | 17,500 | 28,300 | 58,200 | 106,000 | 167,000 | | |
| 40 | 62 | 129 | 243 | 499 | 747 | 1,440 | 2,290 | 4,050 | 8,270 | 15,000 | 24,200 | 49,800 | 90,400 | 143,000 | | |
| 50 | 55 | 114 | 215 | 442 | 662 | 1,280 | 2,030 | 3,590 | 7,330 | 13,300 | 21,500 | 44,100 | 80,100 | 127,000 | | |
| 60 | 50 | 104 | 195 | 400 | 600 | 1,160 | 1,840 | 3,260 | 6,640 | 12,000 | 19,500 | 40,000 | 72,600 | 115,000 | | |
| 70 | 46 | 95 | 179 | 368 | 552 | 1,060 | 1,690 | 3,000 | 6,110 | 11,100 | 17,900 | 36,800 | 66,800 | 106,000 | | |
| 80 | 42 | 89 | 167 | 343 | 514 | 989 | 1,580 | 2,790 | 5,680 | 10,300 | 16,700 | 34,200 | 62,100 | 98,400 | | |
| 90 | 40 | 83 | 157 | 322 | 482 | 928 | 1,480 | 2,610 | 5,330 | 9,650 | 15,600 | 32,100 | 58,300 | 92,300 | | |
| 100 | 38 | 79 | 148 | 304 | 455 | 877 | 1,400 | 2,470 | 5,040 | 9,110 | 14,800 | 30,300 | 55,100 | 87,200 | | |
| 125 | 33 | 70 | 131 | 269 | 403 | 777 | 1,240 | 2,190 | 4,460 | 8,080 | 13,100 | 26,900 | 48,800 | 77,300 | | |
| 150 | 30 | 63 | 119 | 244 | 366 | 704 | 1,120 | 1,980 | 4,050 | 7,320 | 11,900 | 24,300 | 44,200 | 70,000 | | |
| 175 | 28 | 58 | 109 | 224 | 336 | 648 | 1,030 | 1,820 | 3,720 | 6,730 | 10,900 | 22,400 | 40,700 | 64,400 | | |
| 200 | 26 | 54 | 102 | 209 | 313 | 602 | 960 | 1,700 | 3,460 | 6,260 | 10,100 | 20,800 | 37,900 | 59,900 | | |
| 250 | 23 | 48 | 90 | 185 | 277 | 534 | 851 | 1,500 | 3,070 | 5,550 | 8,990 | 18,500 | 33,500 | 53,100 | | |
| 300 | 21 | 43 | 82 | 168 | 251 | 484 | 771 | 1,360 | 2,780 | 5,030 | 8,150 | 16,700 | 30,400 | 48,100 | | |
| 350 | 19 | 40 | 75 | 154 | 231 | 445 | 709 | 1,250 | 2,560 | 4,630 | 7,490 | 15,400 | 28,000 | 44,300 | | |
| 400 | 18 | 37 | 70 | 143 | 215 | 414 | 660 | 1,170 | 2,380 | 4,310 | 6,970 | 14,300 | 26,000 | 41,200 | | |
| 450 | 17 | 35 | 66 | 135 | 202 | 389 | 619 | 1,090 | 2,230 | 4,040 | 6,540 | 13,400 | 24,400 | 38,600 | | |
| 500 | 16 | 33 | 62 | 127 | 191 | 367 | 585 | 1,030 | 2,110 | 3,820 | 6,180 | 12,700 | 23,100 | 36,500 | | |
| 550 | 15 | 31 | 59 | 121 | 181 | 349 | 556 | 982 | 2,000 | 3,620 | 5,870 | 12,100 | 21,900 | 34,700 | | |
| 600 | 14 | 30 | 56 | 115 | 173 | 333 | 530 | 937 | 1,910 | 3,460 | 5,600 | 11,500 | 20,900 | 33,100 | | |
| 650 | 14 | 29 | 54 | 110 | 165 | 318 | 508 | 897 | 1,830 | 3,310 | 5,360 | 11,000 | 20,000 | 31,700 | | |
| 700 | 13 | 27 | 52 | 106 | 159 | 306 | 488 | 862 | 1,760 | 3,180 | 5,150 | 10,600 | 19,200 | 30,400 | | |
| 750 | 13 | 26 | 50 | 102 | 153 | 295 | 470 | 830 | 1,690 | 3,060 | 4,960 | 10,200 | 18,500 | 29,300 | | |
| 800 | 12 | 26 | 48 | 99 | 148 | 285 | 454 | 802 | 1,640 | 2,960 | 4,790 | 9,840 | 17,900 | 28,300 | | |
| 850 | 12 | 25 | 46 | 95 | 143 | 275 | 439 | 776 | 1,580 | 2,860 | 4,640 | 9,530 | 17,300 | 27,400 | | |
| 900 | 11 | 24 | 45 | 93 | 139 | 267 | 426 | 752 | 1,530 | 2,780 | 4,500 | 9,240 | 16,800 | 26,600 | | |
| 950 | 11 | 23 | 44 | 90 | 135 | 259 | 413 | 731 | 1,490 | 2,700 | 4,370 | 8,970 | 16,300 | 25,800 | | |
| 1,000 | 11 | 23 | 43 | 87 | 131 | 252 | 402 | 711 | 1,450 | 2,620 | 4,250 | 8,720 | 15,800 | 25,100 | | |
| 1,100 | 10 | 21 | 40 | 83 | 124 | 240 | 382 | 675 | 1,380 | 2,490 | 4,030 | 8,290 | 15,100 | 23,800 | | |
| 1,200 | NA | 20 | 39 | 79 | 119 | 229 | 364 | 644 | 1,310 | 2,380 | 3,850 | 7,910 | 14,400 | 22,700 | | |
| 1,300 | NA | 20 | 37 | 76 | 114 | 219 | 349 | 617 | 1,260 | 2,280 | 3,680 | 7,570 | 13,700 | 21,800 | | |
| 1,400 | NA | 19 | 35 | 73 | 109 | 210 | 335 | 592 | 1,210 | 2,190 | 3,540 | 7,270 | 13,200 | 20,900 | | |
| 1,500 | NA | 18 | 34 | 70 | 105 | 203 | 323 | 571 | 1,160 | 2,110 | 3,410 | 7,010 | 12,700 | 20,100 | | |
| 1,600 | NA | 18 | 33 | 68 | 102 | 196 | 312 | 551 | 1,120 | 2,030 | 3,290 | 6,770 | 12,300 | 19,500 | | |
| 1,700 | NA | 17 | 32 | 66 | 98 | 189 | 302 | 533 | 1,090 | 1,970 | 3,190 | 6,550 | 11,900 | 18,800 | | |
| 1,800 | NA | 16 | 31 | 64 | 95 | 184 | 293 | 517 | 1,050 | 1,910 | 3,090 | 6,350 | 11,500 | 18,300 | | |
| 1,900 | NA | 16 | 30 | 62 | 93 | 178 | 284 | 502 | 1,020 | 1,850 | 3,000 | 6,170 | 11,200 | 17,700 | | |
| 2,000 | NA | 16 | 29 | 60 | 90 | 173 | 276 | 488 | 1,000 | 1,800 | 2,920 | 6,000 | 10,900 | 17,200 | | |

NA: A flow of less than 10 cfh.

Note: All table entries are rounded to 3 significant digits.

Table 6.2.1(b) Schedule 40 Metallic Pipe

| | | | | | | | | | | | | | Gas: Natural | | |
|-------------|----------------------------------------|-------|-------|-------|-------|-------|-------|--------|--------|--------|--------|---------|---------------------------------|---------|--|
| | | | | | | | | | | | | | Inlet Pressure: Less than 2 psi | | |
| | | | | | | | | | | | | | Pressure Drop: 0.5 in. w.c. | | |
| | | | | | | | | | | | | | Specific Gravity: 0.60 | | |
| | | | | | | | | | | | | | Pipe Size (in.) | | |
| Nominal: | ½ | ¾ | 1 | 1¼ | 1½ | 2 | 2½ | 3 | 4 | 5 | 6 | 8 | 10 | 12 | |
| Actual ID: | 0.622 | 0.824 | 1.049 | 1.380 | 1.610 | 2.067 | 2.469 | 3.068 | 4.026 | 5.047 | 6.065 | 7.981 | 10.020 | 11.938 | |
| Length (ft) | Capacity in Cubic Feet of Gas per Hour | | | | | | | | | | | | | | |
| 10 | 172 | 360 | 678 | 1,390 | 2,090 | 4,020 | 6,400 | 11,300 | 23,100 | 41,800 | 67,600 | 139,000 | 252,000 | 399,000 | |
| 20 | 118 | 247 | 466 | 957 | 1,430 | 2,760 | 4,400 | 7,780 | 15,900 | 28,700 | 46,500 | 95,500 | 173,000 | 275,000 | |
| 30 | 95 | 199 | 374 | 768 | 1,150 | 2,220 | 3,530 | 6,250 | 12,700 | 23,000 | 37,300 | 76,700 | 139,000 | 220,000 | |
| 40 | 81 | 170 | 320 | 657 | 985 | 1,900 | 3,020 | 5,350 | 10,900 | 19,700 | 31,900 | 65,600 | 119,000 | 189,000 | |
| 50 | 72 | 151 | 284 | 583 | 873 | 1,680 | 2,680 | 4,740 | 9,660 | 17,500 | 28,300 | 58,200 | 106,000 | 167,000 | |
| 60 | 65 | 137 | 257 | 528 | 791 | 1,520 | 2,430 | 4,290 | 8,760 | 15,800 | 25,600 | 52,700 | 95,700 | 152,000 | |
| 70 | 60 | 126 | 237 | 486 | 728 | 1,400 | 2,230 | 3,950 | 8,050 | 14,600 | 23,600 | 48,500 | 88,100 | 139,000 | |
| 80 | 56 | 117 | 220 | 452 | 677 | 1,300 | 2,080 | 3,670 | 7,490 | 13,600 | 22,000 | 45,100 | 81,900 | 130,000 | |
| 90 | 52 | 110 | 207 | 424 | 635 | 1,220 | 1,950 | 3,450 | 7,030 | 12,700 | 20,600 | 42,300 | 76,900 | 122,000 | |
| 100 | 50 | 104 | 195 | 400 | 600 | 1,160 | 1,840 | 3,260 | 6,640 | 12,000 | 19,500 | 40,000 | 72,600 | 115,000 | |
| 125 | 44 | 92 | 173 | 355 | 532 | 1,020 | 1,630 | 2,890 | 5,890 | 10,600 | 17,200 | 35,400 | 64,300 | 102,000 | |
| 150 | 40 | 83 | 157 | 322 | 482 | 928 | 1,480 | 2,610 | 5,330 | 9,650 | 15,600 | 32,100 | 58,300 | 92,300 | |
| 175 | 37 | 77 | 144 | 296 | 443 | 854 | 1,360 | 2,410 | 4,910 | 8,880 | 14,400 | 29,500 | 53,600 | 84,900 | |
| 200 | 34 | 71 | 134 | 275 | 412 | 794 | 1,270 | 2,240 | 4,560 | 8,260 | 13,400 | 27,500 | 49,900 | 79,000 | |
| 250 | 30 | 63 | 119 | 244 | 366 | 704 | 1,120 | 1,980 | 4,050 | 7,320 | 11,900 | 24,300 | 44,200 | 70,000 | |
| 300 | 27 | 57 | 108 | 221 | 331 | 638 | 1,020 | 1,800 | 3,670 | 6,630 | 10,700 | 22,100 | 40,100 | 63,400 | |
| 350 | 25 | 53 | 99 | 203 | 305 | 587 | 935 | 1,650 | 3,370 | 6,100 | 9,880 | 20,300 | 36,900 | 58,400 | |
| 400 | 23 | 49 | 92 | 189 | 283 | 546 | 870 | 1,540 | 3,140 | 5,680 | 9,190 | 18,900 | 34,300 | 54,300 | |
| 450 | 22 | 46 | 86 | 177 | 266 | 512 | 816 | 1,440 | 2,940 | 5,330 | 8,620 | 17,700 | 32,200 | 50,900 | |
| 500 | 21 | 43 | 82 | 168 | 251 | 484 | 771 | 1,360 | 2,780 | 5,030 | 8,150 | 16,700 | 30,400 | 48,100 | |
| 550 | 20 | 41 | 78 | 159 | 239 | 459 | 732 | 1,290 | 2,640 | 4,780 | 7,740 | 15,900 | 28,900 | 45,700 | |
| 600 | 19 | 39 | 74 | 152 | 228 | 438 | 699 | 1,240 | 2,520 | 4,560 | 7,380 | 15,200 | 27,500 | 43,600 | |
| 650 | 18 | 38 | 71 | 145 | 218 | 420 | 669 | 1,180 | 2,410 | 4,360 | 7,070 | 14,500 | 26,400 | 41,800 | |
| 700 | 17 | 36 | 68 | 140 | 209 | 403 | 643 | 1,140 | 2,320 | 4,190 | 6,790 | 14,000 | 25,300 | 40,100 | |
| 750 | 17 | 35 | 66 | 135 | 202 | 389 | 619 | 1,090 | 2,230 | 4,040 | 6,540 | 13,400 | 24,400 | 38,600 | |
| 800 | 16 | 34 | 63 | 130 | 195 | 375 | 598 | 1,060 | 2,160 | 3,900 | 6,320 | 13,000 | 23,600 | 37,300 | |
| 850 | 16 | 33 | 61 | 126 | 189 | 363 | 579 | 1,020 | 2,090 | 3,780 | 6,110 | 12,600 | 22,800 | 36,100 | |
| 900 | 15 | 32 | 59 | 122 | 183 | 352 | 561 | 992 | 2,020 | 3,660 | 5,930 | 12,200 | 22,100 | 35,000 | |
| 950 | 15 | 31 | 58 | 118 | 178 | 342 | 545 | 963 | 1,960 | 3,550 | 5,760 | 11,800 | 21,500 | 34,000 | |
| 1,000 | 14 | 30 | 56 | 115 | 173 | 333 | 530 | 937 | 1,910 | 3,460 | 5,600 | 11,500 | 20,900 | 33,100 | |
| 1,100 | 14 | 28 | 53 | 109 | 164 | 316 | 503 | 890 | 1,810 | 3,280 | 5,320 | 10,900 | 19,800 | 31,400 | |
| 1,200 | 13 | 27 | 51 | 104 | 156 | 301 | 480 | 849 | 1,730 | 3,130 | 5,070 | 10,400 | 18,900 | 30,000 | |
| 1,300 | 12 | 26 | 49 | 100 | 150 | 289 | 460 | 813 | 1,660 | 3,000 | 4,860 | 9,980 | 18,100 | 28,700 | |
| 1,400 | 12 | 25 | 47 | 96 | 144 | 277 | 442 | 781 | 1,590 | 2,880 | 4,670 | 9,590 | 17,400 | 27,600 | |
| 1,500 | 11 | 24 | 45 | 93 | 139 | 267 | 426 | 752 | 1,530 | 2,780 | 4,500 | 9,240 | 16,800 | 26,600 | |
| 1,600 | 11 | 23 | 44 | 89 | 134 | 258 | 411 | 727 | 1,480 | 2,680 | 4,340 | 8,920 | 16,200 | 25,600 | |
| 1,700 | 11 | 22 | 42 | 86 | 130 | 250 | 398 | 703 | 1,430 | 2,590 | 4,200 | 8,630 | 15,700 | 24,800 | |
| 1,800 | 10 | 22 | 41 | 84 | 126 | 242 | 386 | 682 | 1,390 | 2,520 | 4,070 | 8,370 | 15,200 | 24,100 | |
| 1,900 | 10 | 21 | 40 | 81 | 122 | 235 | 375 | 662 | 1,350 | 2,440 | 3,960 | 8,130 | 14,800 | 23,400 | |
| 2,000 | NA | 20 | 39 | 79 | 119 | 229 | 364 | 644 | 1,310 | 2,380 | 3,850 | 7,910 | 14,400 | 22,700 | |

NA: A flow of less than 10 cfh.

Note: All table entries are rounded to 3 significant digits.

Table 6.2.1(c) Schedule 40 Metallic Pipe

| Gas: Natural | | | | | | | | | |
|-------------------------------------------------------------------------|----------------------------------------------|---------------|--------------|----------------|----------------|--------------|----------------|--------------|--------------|
| Inlet Pressure: Less than 2 psi | | | | | | | | | |
| Pressure Drop: 3.0 in. w.c. | | | | | | | | | |
| Specific Gravity: 0.60 | | | | | | | | | |
| INTENDED USE: Initial supply pressure of 8.0 in. w.c. or greater | | | | | | | | | |
| Pipe Size (in.) | | | | | | | | | |
| Nominal: | $\frac{1}{2}$ | $\frac{3}{4}$ | 1 | $1\frac{1}{4}$ | $1\frac{1}{2}$ | 2 | $2\frac{1}{2}$ | 3 | 4 |
| Actual ID: | 0.622 | 0.824 | 1.049 | 1.380 | 1.610 | 2.067 | 2.469 | 3.068 | 4.026 |
| Length (ft) | Capacity in Thousands of Btu per Hour | | | | | | | | |
| 10 | 454 | 949 | 1,790 | 3,670 | 5,500 | 10,600 | 16,900 | 29,800 | 60,800 |
| 20 | 312 | 652 | 1,230 | 2,520 | 3,780 | 7,280 | 11,600 | 20,500 | 41,800 |
| 30 | 250 | 524 | 986 | 2,030 | 3,030 | 5,840 | 9,310 | 16,500 | 33,600 |
| 40 | 214 | 448 | 844 | 1,730 | 2,600 | 5,000 | 7,970 | 14,100 | 28,700 |
| 50 | 190 | 397 | 748 | 1,540 | 2,300 | 4,430 | 7,060 | 12,500 | 25,500 |
| 60 | 172 | 360 | 678 | 1,390 | 2,090 | 4,020 | 6,400 | 11,300 | 23,100 |
| 70 | 158 | 331 | 624 | 1,280 | 1,920 | 3,690 | 5,890 | 10,400 | 21,200 |
| 80 | 147 | 308 | 580 | 1,190 | 1,790 | 3,440 | 5,480 | 9,690 | 19,800 |
| 90 | 138 | 289 | 544 | 1,120 | 1,670 | 3,230 | 5,140 | 9,090 | 18,500 |
| 100 | 131 | 273 | 514 | 1,060 | 1,580 | 3,050 | 4,860 | 8,580 | 17,500 |
| 125 | 116 | 242 | 456 | 936 | 1,400 | 2,700 | 4,300 | 7,610 | 15,500 |
| 150 | 105 | 219 | 413 | 848 | 1,270 | 2,450 | 3,900 | 6,890 | 14,100 |
| 175 | 96 | 202 | 380 | 780 | 1,170 | 2,250 | 3,590 | 6,340 | 12,900 |
| 200 | 90 | 188 | 353 | 726 | 1,090 | 2,090 | 3,340 | 5,900 | 12,000 |
| 250 | 80 | 166 | 313 | 643 | 964 | 1,860 | 2,960 | 5,230 | 10,700 |
| 300 | 72 | 151 | 284 | 583 | 873 | 1,680 | 2,680 | 4,740 | 9,660 |
| 350 | 66 | 139 | 261 | 536 | 803 | 1,550 | 2,470 | 4,360 | 8,890 |
| 400 | 62 | 129 | 243 | 499 | 747 | 1,440 | 2,290 | 4,050 | 8,270 |
| 450 | 58 | 121 | 228 | 468 | 701 | 1,350 | 2,150 | 3,800 | 7,760 |
| 500 | 55 | 114 | 215 | 442 | 662 | 1,280 | 2,030 | 3,590 | 7,330 |
| 550 | 52 | 109 | 204 | 420 | 629 | 1,210 | 1,930 | 3,410 | 6,960 |
| 600 | 50 | 104 | 195 | 400 | 600 | 1,160 | 1,840 | 3,260 | 6,640 |
| 650 | 47 | 99 | 187 | 384 | 575 | 1,110 | 1,760 | 3,120 | 6,360 |
| 700 | 46 | 95 | 179 | 368 | 552 | 1,060 | 1,690 | 3,000 | 6,110 |
| 750 | 44 | 92 | 173 | 355 | 532 | 1,020 | 1,630 | 2,890 | 5,890 |
| 800 | 42 | 89 | 167 | 343 | 514 | 989 | 1,580 | 2,790 | 5,680 |
| 850 | 41 | 86 | 162 | 332 | 497 | 957 | 1,530 | 2,700 | 5,500 |
| 900 | 40 | 83 | 157 | 322 | 482 | 928 | 1,480 | 2,610 | 5,330 |
| 950 | 39 | 81 | 152 | 312 | 468 | 901 | 1,440 | 2,540 | 5,180 |
| 1000 | 38 | 79 | 148 | 304 | 455 | 877 | 1,400 | 2,470 | 5,040 |
| 1100 | 36 | 75 | 141 | 289 | 432 | 833 | 1,330 | 2,350 | 4,780 |
| 1200 | 34 | 71 | 134 | 275 | 412 | 794 | 1,270 | 2,240 | 4,560 |
| 1300 | 33 | 68 | 128 | 264 | 395 | 761 | 1,210 | 2,140 | 4,370 |
| 1400 | 31 | 65 | 123 | 253 | 379 | 731 | 1,160 | 2,060 | 4,200 |
| 1500 | 30 | 63 | 119 | 244 | 366 | 704 | 1,120 | 1,980 | 4,050 |
| 1600 | 29 | 61 | 115 | 236 | 353 | 680 | 1,080 | 1,920 | 3,910 |
| 1700 | 28 | 59 | 111 | 228 | 342 | 658 | 1,050 | 1,850 | 3,780 |
| 1800 | 27 | 57 | 108 | 221 | 331 | 638 | 1,020 | 1,800 | 3,670 |
| 1900 | 27 | 56 | 105 | 215 | 322 | 619 | 987 | 1,750 | 3,560 |
| 2000 | 26 | 54 | 102 | 209 | 313 | 602 | 960 | 1,700 | 3,460 |

Note: All table entries are rounded to 3 significant digits.

Table 6.2.1(d) Schedule 40 Metallic Pipe

| | | Gas: | | Natural | | | | | |
|-------------------------------------------------------------------|----------------------------------------|-------------------|-------|-----------------|-------|--------|--------|--------|--------|
| | | Inlet Pressure: | | Less than 2 psi | | | | | |
| | | Pressure Drop: | | 6.0 in. w.c. | | | | | |
| | | Specific Gravity: | | 0.6 | | | | | |
| INTENDED USE: Initial supply pressure of 11.0 in. w.c. or greater | | | | | | | | | |
| Nominal: | Pipe Size (in.) | | | | | | | | |
| | ½ | ¾ | 1 | 1¼ | 1½ | 2 | 2½ | 3 | 4 |
| Actual ID: | 0.622 | 0.824 | 1.049 | 1.38 | 1.61 | 2.067 | 2.469 | 3.068 | 4.026 |
| Length (ft) | Capacity in Cubic Feet of Gas per Hour | | | | | | | | |
| 10 | 660 | 1,380 | 2,600 | 5,340 | 8,000 | 15,400 | 24,600 | 43,400 | 88,500 |
| 20 | 454 | 949 | 1,790 | 3,670 | 5,500 | 10,600 | 16,900 | 29,800 | 60,800 |
| 30 | 364 | 762 | 1,440 | 2,950 | 4,410 | 8,500 | 13,600 | 24,000 | 48,900 |
| 40 | 312 | 652 | 1,230 | 2,520 | 3,780 | 7,280 | 11,600 | 20,500 | 41,800 |
| 50 | 276 | 578 | 1,090 | 2,240 | 3,350 | 6,450 | 10,300 | 18,200 | 37,100 |
| 60 | 250 | 524 | 986 | 2,030 | 3,030 | 5,840 | 9,310 | 16,500 | 33,600 |
| 70 | 230 | 482 | 907 | 1,860 | 2,790 | 5,380 | 8,570 | 15,100 | 30,900 |
| 80 | 214 | 448 | 844 | 1,730 | 2,600 | 5,000 | 7,970 | 14,100 | 28,700 |
| 90 | 201 | 420 | 792 | 1,630 | 2,440 | 4,690 | 7,480 | 13,200 | 27,000 |
| 100 | 190 | 397 | 748 | 1,540 | 2,300 | 4,430 | 7,060 | 12,500 | 25,500 |
| 125 | 168 | 352 | 663 | 1,360 | 2,040 | 3,930 | 6,260 | 11,100 | 22,600 |
| 150 | 153 | 319 | 601 | 1,230 | 1,850 | 3,560 | 5,670 | 10,000 | 20,500 |
| 175 | 140 | 293 | 553 | 1,140 | 1,700 | 3,270 | 5,220 | 9,230 | 18,800 |
| 200 | 131 | 273 | 514 | 1,056 | 1,580 | 3,050 | 4,860 | 8,580 | 17,500 |
| 250 | 116 | 242 | 456 | 936 | 1,400 | 2,700 | 4,300 | 7,610 | 15,500 |
| 300 | 105 | 219 | 413 | 848 | 1,270 | 2,450 | 3,900 | 6,890 | 14,100 |
| 350 | 96 | 202 | 380 | 780 | 1,170 | 2,250 | 3,590 | 6,340 | 12,900 |
| 400 | 90 | 188 | 353 | 726 | 1,090 | 2,090 | 3,340 | 5,900 | 12,000 |
| 450 | 84 | 176 | 332 | 681 | 1,020 | 1,960 | 3,130 | 5,540 | 11,300 |
| 500 | 80 | 166 | 313 | 643 | 964 | 1,860 | 2,960 | 5,230 | 10,700 |
| 550 | 76 | 158 | 297 | 611 | 915 | 1,760 | 2,810 | 4,970 | 10,100 |
| 600 | 72 | 151 | 284 | 583 | 873 | 1,680 | 2,680 | 4,740 | 9,660 |
| 650 | 69 | 144 | 272 | 558 | 836 | 1,610 | 2,570 | 4,540 | 9,250 |
| 700 | 66 | 139 | 261 | 536 | 803 | 1,550 | 2,470 | 4,360 | 8,890 |
| 750 | 64 | 134 | 252 | 516 | 774 | 1,490 | 2,380 | 4,200 | 8,560 |
| 800 | 62 | 129 | 243 | 499 | 747 | 1,440 | 2,290 | 4,050 | 8,270 |
| 850 | 60 | 125 | 235 | 483 | 723 | 1,390 | 2,220 | 3,920 | 8,000 |
| 900 | 58 | 121 | 228 | 468 | 701 | 1,350 | 2,150 | 3,800 | 7,760 |
| 950 | 56 | 118 | 221 | 454 | 681 | 1,310 | 2,090 | 3,690 | 7,540 |
| 1,000 | 55 | 114 | 215 | 442 | 662 | 1,280 | 2,030 | 3,590 | 7,330 |
| 1,100 | 52 | 109 | 204 | 420 | 629 | 1,210 | 1,930 | 3,410 | 6,960 |
| 1,200 | 50 | 104 | 195 | 400 | 600 | 1,160 | 1,840 | 3,260 | 6,640 |
| 1,300 | 47 | 99 | 187 | 384 | 575 | 1,110 | 1,760 | 3,120 | 6,360 |
| 1,400 | 46 | 95 | 179 | 368 | 552 | 1,060 | 1,690 | 3,000 | 6,110 |
| 1,500 | 44 | 92 | 173 | 355 | 532 | 1,020 | 1,630 | 2,890 | 5,890 |
| 1,600 | 42 | 89 | 167 | 343 | 514 | 989 | 1,580 | 2,790 | 5,680 |
| 1,700 | 41 | 86 | 162 | 332 | 497 | 957 | 1,530 | 2,700 | 5,500 |
| 1,800 | 40 | 83 | 157 | 322 | 482 | 928 | 1,480 | 2,610 | 5,330 |
| 1,900 | 39 | 81 | 152 | 312 | 468 | 901 | 1,440 | 2,540 | 5,180 |
| 2,000 | 38 | 79 | 148 | 304 | 455 | 877 | 1,400 | 2,470 | 5,040 |

Note: All table entries are rounded to 3 significant digits.

Table 6.2.1(e) Schedule 40 Metallic Pipe

| | | | | | | | | | | Gas: Natural | | | | | | | | | | |
|-------------|----------------------------------------|-------|-------|--------|--------|--------|--------|--------|---------|-------------------------|--|--|--|--|--|--|--|--|--|--|
| | | | | | | | | | | Inlet Pressure: 2.0 psi | | | | | | | | | | |
| | | | | | | | | | | Pressure Drop: 1.0 psi | | | | | | | | | | |
| | | | | | | | | | | Specific Gravity: 0.60 | | | | | | | | | | |
| | | | | | | | | | | Pipe Size (in.) | | | | | | | | | | |
| Nominal: | ½ | ¾ | 1 | 1¼ | 1½ | 2 | 2½ | 3 | 4 | | | | | | | | | | | |
| Actual ID: | 0.622 | 0.824 | 1.049 | 1.380 | 1.610 | 2.067 | 2.469 | 3.068 | 4.026 | | | | | | | | | | | |
| Length (ft) | Capacity in Cubic Feet of Gas per Hour | | | | | | | | | | | | | | | | | | | |
| 10 | 1,510 | 3,040 | 5,560 | 11,400 | 17,100 | 32,900 | 52,500 | 92,800 | 189,000 | | | | | | | | | | | |
| 20 | 1,070 | 2,150 | 3,930 | 8,070 | 12,100 | 23,300 | 37,100 | 65,600 | 134,000 | | | | | | | | | | | |
| 30 | 869 | 1,760 | 3,210 | 6,590 | 9,880 | 19,000 | 30,300 | 53,600 | 109,000 | | | | | | | | | | | |
| 40 | 753 | 1,520 | 2,780 | 5,710 | 8,550 | 16,500 | 26,300 | 46,400 | 94,700 | | | | | | | | | | | |
| 50 | 673 | 1,360 | 2,490 | 5,110 | 7,650 | 14,700 | 23,500 | 41,500 | 84,700 | | | | | | | | | | | |
| 60 | 615 | 1,240 | 2,270 | 4,660 | 6,980 | 13,500 | 21,400 | 37,900 | 77,300 | | | | | | | | | | | |
| 70 | 569 | 1,150 | 2,100 | 4,320 | 6,470 | 12,500 | 19,900 | 35,100 | 71,600 | | | | | | | | | | | |
| 80 | 532 | 1,080 | 1,970 | 4,040 | 6,050 | 11,700 | 18,600 | 32,800 | 67,000 | | | | | | | | | | | |
| 90 | 502 | 1,010 | 1,850 | 3,810 | 5,700 | 11,000 | 17,500 | 30,900 | 63,100 | | | | | | | | | | | |
| 100 | 462 | 934 | 1,710 | 3,510 | 5,260 | 10,100 | 16,100 | 28,500 | 58,200 | | | | | | | | | | | |
| 125 | 414 | 836 | 1,530 | 3,140 | 4,700 | 9,060 | 14,400 | 25,500 | 52,100 | | | | | | | | | | | |
| 150 | 372 | 751 | 1,370 | 2,820 | 4,220 | 8,130 | 13,000 | 22,900 | 46,700 | | | | | | | | | | | |
| 175 | 344 | 695 | 1,270 | 2,601 | 3,910 | 7,530 | 12,000 | 21,200 | 43,300 | | | | | | | | | | | |
| 200 | 318 | 642 | 1,170 | 2,410 | 3,610 | 6,960 | 11,100 | 19,600 | 40,000 | | | | | | | | | | | |
| 250 | 279 | 583 | 1,040 | 2,140 | 3,210 | 6,180 | 9,850 | 17,400 | 35,500 | | | | | | | | | | | |
| 300 | 253 | 528 | 945 | 1,940 | 2,910 | 5,600 | 8,920 | 15,800 | 32,200 | | | | | | | | | | | |
| 350 | 232 | 486 | 869 | 1,790 | 2,670 | 5,150 | 8,210 | 14,500 | 29,600 | | | | | | | | | | | |
| 400 | 216 | 452 | 809 | 1,660 | 2,490 | 4,790 | 7,640 | 13,500 | 27,500 | | | | | | | | | | | |
| 450 | 203 | 424 | 759 | 1,560 | 2,330 | 4,500 | 7,170 | 12,700 | 25,800 | | | | | | | | | | | |
| 500 | 192 | 401 | 717 | 1,470 | 2,210 | 4,250 | 6,770 | 12,000 | 24,400 | | | | | | | | | | | |
| 550 | 182 | 381 | 681 | 1,400 | 2,090 | 4,030 | 6,430 | 11,400 | 23,200 | | | | | | | | | | | |
| 600 | 174 | 363 | 650 | 1,330 | 2,000 | 3,850 | 6,130 | 10,800 | 22,100 | | | | | | | | | | | |
| 650 | 166 | 348 | 622 | 1,280 | 1,910 | 3,680 | 5,870 | 10,400 | 21,200 | | | | | | | | | | | |
| 700 | 160 | 334 | 598 | 1,230 | 1,840 | 3,540 | 5,640 | 9,970 | 20,300 | | | | | | | | | | | |
| 750 | 154 | 322 | 576 | 1,180 | 1,770 | 3,410 | 5,440 | 9,610 | 19,600 | | | | | | | | | | | |
| 800 | 149 | 311 | 556 | 1,140 | 1,710 | 3,290 | 5,250 | 9,280 | 18,900 | | | | | | | | | | | |
| 850 | 144 | 301 | 538 | 1,100 | 1,650 | 3,190 | 5,080 | 8,980 | 18,300 | | | | | | | | | | | |
| 900 | 139 | 292 | 522 | 1,070 | 1,600 | 3,090 | 4,930 | 8,710 | 17,800 | | | | | | | | | | | |
| 950 | 135 | 283 | 507 | 1,040 | 1,560 | 3,000 | 4,780 | 8,460 | 17,200 | | | | | | | | | | | |
| 1,000 | 132 | 275 | 493 | 1,010 | 1,520 | 2,920 | 4,650 | 8,220 | 16,800 | | | | | | | | | | | |
| 1,100 | 125 | 262 | 468 | 960 | 1,440 | 2,770 | 4,420 | 7,810 | 15,900 | | | | | | | | | | | |
| 1,200 | 119 | 250 | 446 | 917 | 1,370 | 2,640 | 4,220 | 7,450 | 15,200 | | | | | | | | | | | |
| 1,300 | 114 | 239 | 427 | 878 | 1,320 | 2,530 | 4,040 | 7,140 | 14,600 | | | | | | | | | | | |
| 1,400 | 110 | 230 | 411 | 843 | 1,260 | 2,430 | 3,880 | 6,860 | 14,000 | | | | | | | | | | | |
| 1,500 | 106 | 221 | 396 | 812 | 1,220 | 2,340 | 3,740 | 6,600 | 13,500 | | | | | | | | | | | |
| 1,600 | 102 | 214 | 382 | 784 | 1,180 | 2,260 | 3,610 | 6,380 | 13,000 | | | | | | | | | | | |
| 1,700 | 99 | 207 | 370 | 759 | 1,140 | 2,190 | 3,490 | 6,170 | 12,600 | | | | | | | | | | | |
| 1,800 | 96 | 200 | 358 | 736 | 1,100 | 2,120 | 3,390 | 5,980 | 12,200 | | | | | | | | | | | |
| 1,900 | 93 | 195 | 348 | 715 | 1,070 | 2,060 | 3,290 | 5,810 | 11,900 | | | | | | | | | | | |
| 2,000 | 91 | 189 | 339 | 695 | 1,040 | 2,010 | 3,200 | 5,650 | 11,500 | | | | | | | | | | | |

Note: All table entries are rounded to 3 significant digits.

Table 6.2.1(f) Schedule 40 Metallic Pipe

| | | | | | | | | | | Gas: Natural | | | | | | | | | | |
|-------------|----------------------------------------|-------|-------|--------|--------|--------|--------|---------|---------|-------------------------|--|--|--|--|--|--|--|--|--|--|
| | | | | | | | | | | Inlet Pressure: 3.0 psi | | | | | | | | | | |
| | | | | | | | | | | Pressure Drop: 2.0 psi | | | | | | | | | | |
| | | | | | | | | | | Specific Gravity: 0.60 | | | | | | | | | | |
| | | | | | | | | | | Pipe Size (in.) | | | | | | | | | | |
| Nominal: | ½ | ¾ | 1 | 1¼ | 1½ | 2 | 2½ | 3 | 4 | | | | | | | | | | | |
| Actual ID: | 0.622 | 0.824 | 1.049 | 1.380 | 1.610 | 2.067 | 2.469 | 3.068 | 4.026 | | | | | | | | | | | |
| Length (ft) | Capacity in Cubic Feet of Gas per Hour | | | | | | | | | | | | | | | | | | | |
| 10 | 2,350 | 4,920 | 9,270 | 19,000 | 28,500 | 54,900 | 87,500 | 155,000 | 316,000 | | | | | | | | | | | |
| 20 | 1,620 | 3,380 | 6,370 | 13,100 | 19,600 | 37,700 | 60,100 | 106,000 | 217,000 | | | | | | | | | | | |
| 30 | 1,300 | 2,720 | 5,110 | 10,500 | 15,700 | 30,300 | 48,300 | 85,400 | 174,000 | | | | | | | | | | | |
| 40 | 1,110 | 2,320 | 4,380 | 8,990 | 13,500 | 25,900 | 41,300 | 73,100 | 149,000 | | | | | | | | | | | |
| 50 | 985 | 2,060 | 3,880 | 7,970 | 11,900 | 23,000 | 36,600 | 64,800 | 132,000 | | | | | | | | | | | |
| 60 | 892 | 1,870 | 3,520 | 7,220 | 10,800 | 20,800 | 33,200 | 58,700 | 120,000 | | | | | | | | | | | |
| 70 | 821 | 1,720 | 3,230 | 6,640 | 9,950 | 19,200 | 30,500 | 54,000 | 110,000 | | | | | | | | | | | |
| 80 | 764 | 1,600 | 3,010 | 6,180 | 9,260 | 17,800 | 28,400 | 50,200 | 102,000 | | | | | | | | | | | |
| 90 | 717 | 1,500 | 2,820 | 5,800 | 8,680 | 16,700 | 26,700 | 47,100 | 96,100 | | | | | | | | | | | |
| 100 | 677 | 1,420 | 2,670 | 5,470 | 8,200 | 15,800 | 25,200 | 44,500 | 90,800 | | | | | | | | | | | |
| 125 | 600 | 1,250 | 2,360 | 4,850 | 7,270 | 14,000 | 22,300 | 39,500 | 80,500 | | | | | | | | | | | |
| 150 | 544 | 1,140 | 2,140 | 4,400 | 6,590 | 12,700 | 20,200 | 35,700 | 72,900 | | | | | | | | | | | |
| 175 | 500 | 1,050 | 1,970 | 4,040 | 6,060 | 11,700 | 18,600 | 32,900 | 67,100 | | | | | | | | | | | |
| 200 | 465 | 973 | 1,830 | 3,760 | 5,640 | 10,900 | 17,300 | 30,600 | 62,400 | | | | | | | | | | | |
| 250 | 412 | 862 | 1,620 | 3,330 | 5,000 | 9,620 | 15,300 | 27,100 | 55,300 | | | | | | | | | | | |
| 300 | 374 | 781 | 1,470 | 3,020 | 4,530 | 8,720 | 13,900 | 24,600 | 50,100 | | | | | | | | | | | |
| 350 | 344 | 719 | 1,350 | 2,780 | 4,170 | 8,020 | 12,800 | 22,600 | 46,100 | | | | | | | | | | | |
| 400 | 320 | 669 | 1,260 | 2,590 | 3,870 | 7,460 | 11,900 | 21,000 | 42,900 | | | | | | | | | | | |
| 450 | 300 | 627 | 1,180 | 2,430 | 3,640 | 7,000 | 11,200 | 19,700 | 40,200 | | | | | | | | | | | |
| 500 | 283 | 593 | 1,120 | 2,290 | 3,430 | 6,610 | 10,500 | 18,600 | 38,000 | | | | | | | | | | | |
| 550 | 269 | 563 | 1,060 | 2,180 | 3,260 | 6,280 | 10,000 | 17,700 | 36,100 | | | | | | | | | | | |
| 600 | 257 | 537 | 1,010 | 2,080 | 3,110 | 5,990 | 9,550 | 16,900 | 34,400 | | | | | | | | | | | |
| 650 | 246 | 514 | 969 | 1,990 | 2,980 | 5,740 | 9,150 | 16,200 | 33,000 | | | | | | | | | | | |
| 700 | 236 | 494 | 931 | 1,910 | 2,860 | 5,510 | 8,790 | 15,500 | 31,700 | | | | | | | | | | | |
| 750 | 228 | 476 | 897 | 1,840 | 2,760 | 5,310 | 8,470 | 15,000 | 30,500 | | | | | | | | | | | |
| 800 | 220 | 460 | 866 | 1,780 | 2,660 | 5,130 | 8,180 | 14,500 | 29,500 | | | | | | | | | | | |
| 850 | 213 | 445 | 838 | 1,720 | 2,580 | 4,960 | 7,910 | 14,000 | 28,500 | | | | | | | | | | | |
| 900 | 206 | 431 | 812 | 1,670 | 2,500 | 4,810 | 7,670 | 13,600 | 27,700 | | | | | | | | | | | |
| 950 | 200 | 419 | 789 | 1,620 | 2,430 | 4,670 | 7,450 | 13,200 | 26,900 | | | | | | | | | | | |
| 1,000 | 195 | 407 | 767 | 1,580 | 2,360 | 4,550 | 7,240 | 12,800 | 26,100 | | | | | | | | | | | |
| 1,100 | 185 | 387 | 729 | 1,500 | 2,240 | 4,320 | 6,890 | 12,200 | 24,800 | | | | | | | | | | | |
| 1,200 | 177 | 369 | 695 | 1,430 | 2,140 | 4,120 | 6,570 | 11,600 | 23,700 | | | | | | | | | | | |
| 1,300 | 169 | 353 | 666 | 1,370 | 2,050 | 3,940 | 6,290 | 11,100 | 22,700 | | | | | | | | | | | |
| 1,400 | 162 | 340 | 640 | 1,310 | 1,970 | 3,790 | 6,040 | 10,700 | 21,800 | | | | | | | | | | | |
| 1,500 | 156 | 327 | 616 | 1,270 | 1,900 | 3,650 | 5,820 | 10,300 | 21,000 | | | | | | | | | | | |
| 1,600 | 151 | 316 | 595 | 1,220 | 1,830 | 3,530 | 5,620 | 10,000 | 20,300 | | | | | | | | | | | |
| 1,700 | 146 | 306 | 576 | 1,180 | 1,770 | 3,410 | 5,440 | 9,610 | 19,600 | | | | | | | | | | | |
| 1,800 | 142 | 296 | 558 | 1,150 | 1,720 | 3,310 | 5,270 | 9,320 | 19,000 | | | | | | | | | | | |
| 1,900 | 138 | 288 | 542 | 1,110 | 1,670 | 3,210 | 5,120 | 9,050 | 18,400 | | | | | | | | | | | |
| 2,000 | 134 | 280 | 527 | 1,080 | 1,620 | 3,120 | 4,980 | 8,800 | 18,000 | | | | | | | | | | | |

Note: All table entries are rounded to 3 significant digits.

Table 6.2.1(g) Schedule 40 Metallic Pipe

| | | | | | | | | | | Gas: Natural | |
|-----------------|----------------------------------------|-------|--------|--------|--------|--------|---------|---------|---------|-------------------------|--|
| | | | | | | | | | | Inlet Pressure: 5.0 psi | |
| | | | | | | | | | | Pressure Drop: 3.5 psi | |
| | | | | | | | | | | Specific Gravity: 0.60 | |
| Pipe Size (in.) | | | | | | | | | | | |
| Nominal: | ½ | ¾ | 1 | 1¼ | 1½ | 2 | 2½ | 3 | 4 | | |
| Actual ID: | 0.622 | 0.824 | 1.049 | 1.380 | 1.610 | 2.067 | 2.469 | 3.068 | 4.026 | | |
| Length (ft) | Capacity in Cubic Feet of Gas per Hour | | | | | | | | | | |
| 10 | 3,190 | 6,430 | 11,800 | 24,200 | 36,200 | 69,700 | 111,000 | 196,000 | 401,000 | | |
| 20 | 2,250 | 4,550 | 8,320 | 17,100 | 25,600 | 49,300 | 78,600 | 139,000 | 283,000 | | |
| 30 | 1,840 | 3,720 | 6,790 | 14,000 | 20,900 | 40,300 | 64,200 | 113,000 | 231,000 | | |
| 40 | 1,590 | 3,220 | 5,880 | 12,100 | 18,100 | 34,900 | 55,600 | 98,200 | 200,000 | | |
| 50 | 1,430 | 2,880 | 5,260 | 10,800 | 16,200 | 31,200 | 49,700 | 87,900 | 179,000 | | |
| 60 | 1,300 | 2,630 | 4,800 | 9,860 | 14,800 | 28,500 | 45,400 | 80,200 | 164,000 | | |
| 70 | 1,200 | 2,430 | 4,450 | 9,130 | 13,700 | 26,400 | 42,000 | 74,300 | 151,000 | | |
| 80 | 1,150 | 2,330 | 4,260 | 8,540 | 12,800 | 24,700 | 39,300 | 69,500 | 142,000 | | |
| 90 | 1,060 | 2,150 | 3,920 | 8,050 | 12,100 | 23,200 | 37,000 | 65,500 | 134,000 | | |
| 100 | 979 | 1,980 | 3,620 | 7,430 | 11,100 | 21,400 | 34,200 | 60,400 | 123,000 | | |
| 125 | 876 | 1,770 | 3,240 | 6,640 | 9,950 | 19,200 | 30,600 | 54,000 | 110,000 | | |
| 150 | 786 | 1,590 | 2,910 | 5,960 | 8,940 | 17,200 | 27,400 | 48,500 | 98,900 | | |
| 175 | 728 | 1,470 | 2,690 | 5,520 | 8,270 | 15,900 | 25,400 | 44,900 | 91,600 | | |
| 200 | 673 | 1,360 | 2,490 | 5,100 | 7,650 | 14,700 | 23,500 | 41,500 | 84,700 | | |
| 250 | 558 | 1,170 | 2,200 | 4,510 | 6,760 | 13,000 | 20,800 | 36,700 | 74,900 | | |
| 300 | 506 | 1,060 | 1,990 | 4,090 | 6,130 | 11,800 | 18,800 | 33,300 | 67,800 | | |
| 350 | 465 | 973 | 1,830 | 3,760 | 5,640 | 10,900 | 17,300 | 30,600 | 62,400 | | |
| 400 | 433 | 905 | 1,710 | 3,500 | 5,250 | 10,100 | 16,100 | 28,500 | 58,100 | | |
| 450 | 406 | 849 | 1,600 | 3,290 | 4,920 | 9,480 | 15,100 | 26,700 | 54,500 | | |
| 500 | 384 | 802 | 1,510 | 3,100 | 4,650 | 8,950 | 14,300 | 25,200 | 51,500 | | |
| 550 | 364 | 762 | 1,440 | 2,950 | 4,420 | 8,500 | 13,600 | 24,000 | 48,900 | | |
| 600 | 348 | 727 | 1,370 | 2,810 | 4,210 | 8,110 | 12,900 | 22,900 | 46,600 | | |
| 650 | 333 | 696 | 1,310 | 2,690 | 4,030 | 7,770 | 12,400 | 21,900 | 44,600 | | |
| 700 | 320 | 669 | 1,260 | 2,590 | 3,880 | 7,460 | 11,900 | 21,000 | 42,900 | | |
| 750 | 308 | 644 | 1,210 | 2,490 | 3,730 | 7,190 | 11,500 | 20,300 | 41,300 | | |
| 800 | 298 | 622 | 1,170 | 2,410 | 3,610 | 6,940 | 11,100 | 19,600 | 39,900 | | |
| 850 | 288 | 602 | 1,130 | 2,330 | 3,490 | 6,720 | 10,700 | 18,900 | 38,600 | | |
| 900 | 279 | 584 | 1,100 | 2,260 | 3,380 | 6,520 | 10,400 | 18,400 | 37,400 | | |
| 950 | 271 | 567 | 1,070 | 2,190 | 3,290 | 6,330 | 10,100 | 17,800 | 36,400 | | |
| 1,000 | 264 | 551 | 1,040 | 2,130 | 3,200 | 6,150 | 9,810 | 17,300 | 35,400 | | |
| 1,100 | 250 | 524 | 987 | 2,030 | 3,030 | 5,840 | 9,320 | 16,500 | 33,600 | | |
| 1,200 | 239 | 500 | 941 | 1,930 | 2,900 | 5,580 | 8,890 | 15,700 | 32,000 | | |
| 1,300 | 229 | 478 | 901 | 1,850 | 2,770 | 5,340 | 8,510 | 15,000 | 30,700 | | |
| 1,400 | 220 | 460 | 866 | 1,780 | 2,660 | 5,130 | 8,180 | 14,500 | 29,500 | | |
| 1,500 | 212 | 443 | 834 | 1,710 | 2,570 | 4,940 | 7,880 | 13,900 | 28,400 | | |
| 1,600 | 205 | 428 | 806 | 1,650 | 2,480 | 4,770 | 7,610 | 13,400 | 27,400 | | |
| 1,700 | 198 | 414 | 780 | 1,600 | 2,400 | 4,620 | 7,360 | 13,000 | 26,500 | | |
| 1,800 | 192 | 401 | 756 | 1,550 | 2,330 | 4,480 | 7,140 | 12,600 | 25,700 | | |
| 1,900 | 186 | 390 | 734 | 1,510 | 2,260 | 4,350 | 6,930 | 12,300 | 25,000 | | |
| 2,000 | 181 | 379 | 714 | 1,470 | 2,200 | 4,230 | 6,740 | 11,900 | 24,300 | | |

Note: All table entries are rounded to 3 significant digits.

Table 6.2.1(h) Semirigid Copper Tubing

| | | Gas: Natural | | | | | | | | |
|----------------------|--------|----------------------------------------|-------|-------|-------|-------|-------|-------|-------|-------|
| | | Inlet Pressure: Less than 2 psi | | | | | | | | |
| | | Pressure Drop: 0.3 in. w.c. | | | | | | | | |
| | | Specific Gravity: 0.60 | | | | | | | | |
| | | Tube Size (in.) | | | | | | | | |
| Nominal: | K & L: | 1/4 | 3/8 | 1/2 | 5/8 | 3/4 | 1 | 1 1/4 | 1 1/2 | 2 |
| | ACR: | 3/8 | 1/2 | 5/8 | 3/4 | 7/8 | 1 1/8 | 1 3/8 | — | — |
| Outside: | | 0.375 | 0.500 | 0.625 | 0.750 | 0.875 | 1.125 | 1.375 | 1.625 | 2.125 |
| Inside: ^a | | 0.305 | 0.402 | 0.527 | 0.652 | 0.745 | 0.995 | 1.245 | 1.481 | 1.959 |
| Length (ft) | | Capacity in Cubic Feet of Gas per Hour | | | | | | | | |
| 10 | 20 | 42 | 85 | 148 | 210 | 448 | 806 | 1,270 | 2,650 | |
| 20 | 14 | 29 | 58 | 102 | 144 | 308 | 554 | 873 | 1,820 | |
| 30 | 11 | 23 | 47 | 82 | 116 | 247 | 445 | 701 | 1,460 | |
| 40 | 10 | 20 | 40 | 70 | 99 | 211 | 381 | 600 | 1,250 | |
| 50 | NA | 17 | 35 | 62 | 88 | 187 | 337 | 532 | 1,110 | |
| 60 | NA | 16 | 32 | 56 | 79 | 170 | 306 | 482 | 1,000 | |
| 70 | NA | 14 | 29 | 52 | 73 | 156 | 281 | 443 | 924 | |
| 80 | NA | 13 | 27 | 48 | 68 | 145 | 262 | 413 | 859 | |
| 90 | NA | 13 | 26 | 45 | 64 | 136 | 245 | 387 | 806 | |
| 100 | NA | 12 | 24 | 43 | 60 | 129 | 232 | 366 | 761 | |
| 125 | NA | 11 | 22 | 38 | 53 | 114 | 206 | 324 | 675 | |
| 150 | NA | 10 | 20 | 34 | 48 | 103 | 186 | 294 | 612 | |
| 175 | NA | NA | 18 | 31 | 45 | 95 | 171 | 270 | 563 | |
| 200 | NA | NA | 17 | 29 | 41 | 89 | 159 | 251 | 523 | |
| 250 | NA | NA | 15 | 26 | 37 | 78 | 141 | 223 | 464 | |
| 300 | NA | NA | 13 | 23 | 33 | 71 | 128 | 202 | 420 | |
| 350 | NA | NA | 12 | 22 | 31 | 65 | 118 | 186 | 387 | |
| 400 | NA | NA | 11 | 20 | 28 | 61 | 110 | 173 | 360 | |
| 450 | NA | NA | 11 | 19 | 27 | 57 | 103 | 162 | 338 | |
| 500 | NA | NA | 10 | 18 | 25 | 54 | 97 | 153 | 319 | |
| 550 | NA | NA | NA | 17 | 24 | 51 | 92 | 145 | 303 | |
| 600 | NA | NA | NA | 16 | 23 | 49 | 88 | 139 | 289 | |
| 650 | NA | NA | NA | 15 | 22 | 47 | 84 | 133 | 277 | |
| 700 | NA | NA | NA | 15 | 21 | 45 | 81 | 128 | 266 | |
| 750 | NA | NA | NA | 14 | 20 | 43 | 78 | 123 | 256 | |
| 800 | NA | NA | NA | 14 | 20 | 42 | 75 | 119 | 247 | |
| 850 | NA | NA | NA | 13 | 19 | 40 | 73 | 115 | 239 | |
| 900 | NA | NA | NA | 13 | 18 | 39 | 71 | 111 | 232 | |
| 950 | NA | NA | NA | 13 | 18 | 38 | 69 | 108 | 225 | |
| 1,000 | NA | NA | NA | 12 | 17 | 37 | 67 | 105 | 219 | |
| 1,100 | NA | NA | NA | 12 | 16 | 35 | 63 | 100 | 208 | |
| 1,200 | NA | NA | NA | 11 | 16 | 34 | 60 | 95 | 199 | |
| 1,300 | NA | NA | NA | 11 | 15 | 32 | 58 | 91 | 190 | |
| 1,400 | NA | NA | NA | 10 | 14 | 31 | 56 | 88 | 183 | |
| 1,500 | NA | NA | NA | NA | 14 | 30 | 54 | 84 | 176 | |
| 1,600 | NA | NA | NA | NA | 13 | 29 | 52 | 82 | 170 | |
| 1,700 | NA | NA | NA | NA | 13 | 28 | 50 | 79 | 164 | |
| 1,800 | NA | NA | NA | NA | 13 | 27 | 49 | 77 | 159 | |
| 1,900 | NA | NA | NA | NA | 12 | 26 | 47 | 74 | 155 | |
| 2,000 | NA | NA | NA | NA | 12 | 25 | 46 | 72 | 151 | |

NA: A flow of less than 10 cfh.

Note: All table entries are rounded to 3 significant digits.

^aTable capacities are based on Type K copper tubing inside diameter (shown), which has the smallest inside diameter of the copper tubing products.

Table 6.2.1(i) Semirigid Copper Tubing

| | | Gas: Natural | | | | | | | | |
|-------------|--------|----------------------------------------|-------|-------|-------|-------|-------|-------|-------|-------|
| | | Inlet Pressure: Less than 2 psi | | | | | | | | |
| | | Pressure Drop: 0.5 in. w.c. | | | | | | | | |
| | | Specific Gravity: 0.60 | | | | | | | | |
| | | Tube Size (in.) | | | | | | | | |
| Nominal: | K & L: | ¼ | ⅜ | ½ | ⅝ | ¾ | 1 | 1¼ | 1½ | 2 |
| | ACR: | ⅜ | ½ | ⅝ | ¾ | ⅞ | 1⅛ | 1⅜ | — | — |
| Outside: | | 0.375 | 0.500 | 0.625 | 0.750 | 0.875 | 1.125 | 1.375 | 1.625 | 2.125 |
| Inside:* | | 0.305 | 0.402 | 0.527 | 0.652 | 0.745 | 0.995 | 1.245 | 1.481 | 1.959 |
| Length (ft) | | Capacity in Cubic Feet of Gas per Hour | | | | | | | | |
| 10 | 27 | 55 | 111 | 195 | 276 | 590 | 1,060 | 1,680 | 3,490 | |
| 20 | 18 | 38 | 77 | 134 | 190 | 406 | 730 | 1,150 | 2,400 | |
| 30 | 15 | 30 | 61 | 107 | 152 | 326 | 586 | 925 | 1,930 | |
| 40 | 13 | 26 | 53 | 92 | 131 | 279 | 502 | 791 | 1,650 | |
| 50 | 11 | 23 | 47 | 82 | 116 | 247 | 445 | 701 | 1,460 | |
| 60 | 10 | 21 | 42 | 74 | 105 | 224 | 403 | 635 | 1,320 | |
| 70 | NA | 19 | 39 | 68 | 96 | 206 | 371 | 585 | 1,220 | |
| 80 | NA | 18 | 36 | 63 | 90 | 192 | 345 | 544 | 1,130 | |
| 90 | NA | 17 | 34 | 59 | 84 | 180 | 324 | 510 | 1,060 | |
| 100 | NA | 16 | 32 | 56 | 79 | 170 | 306 | 482 | 1,000 | |
| 125 | NA | 14 | 28 | 50 | 70 | 151 | 271 | 427 | 890 | |
| 150 | NA | 13 | 26 | 45 | 64 | 136 | 245 | 387 | 806 | |
| 175 | NA | 12 | 24 | 41 | 59 | 125 | 226 | 356 | 742 | |
| 200 | NA | 11 | 22 | 39 | 55 | 117 | 210 | 331 | 690 | |
| 250 | NA | NA | 20 | 34 | 48 | 103 | 186 | 294 | 612 | |
| 300 | NA | NA | 18 | 31 | 44 | 94 | 169 | 266 | 554 | |
| 350 | NA | NA | 16 | 28 | 40 | 86 | 155 | 245 | 510 | |
| 400 | NA | NA | 15 | 26 | 38 | 80 | 144 | 228 | 474 | |
| 450 | NA | NA | 14 | 25 | 35 | 75 | 135 | 214 | 445 | |
| 500 | NA | NA | 13 | 23 | 33 | 71 | 128 | 202 | 420 | |
| 550 | NA | NA | 13 | 22 | 32 | 68 | 122 | 192 | 399 | |
| 600 | NA | NA | 12 | 21 | 30 | 64 | 116 | 183 | 381 | |
| 650 | NA | NA | 12 | 20 | 29 | 62 | 111 | 175 | 365 | |
| 700 | NA | NA | 11 | 20 | 28 | 59 | 107 | 168 | 350 | |
| 750 | NA | NA | 11 | 19 | 27 | 57 | 103 | 162 | 338 | |
| 800 | NA | NA | 10 | 18 | 26 | 55 | 99 | 156 | 326 | |
| 850 | NA | NA | 10 | 18 | 25 | 53 | 96 | 151 | 315 | |
| 900 | NA | NA | NA | 17 | 24 | 52 | 93 | 147 | 306 | |
| 950 | NA | NA | NA | 17 | 24 | 50 | 90 | 143 | 297 | |
| 1,000 | NA | NA | NA | 16 | 23 | 49 | 88 | 139 | 289 | |
| 1,100 | NA | NA | NA | 15 | 22 | 46 | 84 | 132 | 274 | |
| 1,200 | NA | NA | NA | 15 | 21 | 44 | 80 | 126 | 262 | |
| 1,300 | NA | NA | NA | 14 | 20 | 42 | 76 | 120 | 251 | |
| 1,400 | NA | NA | NA | 13 | 19 | 41 | 73 | 116 | 241 | |
| 1,500 | NA | NA | NA | 13 | 18 | 39 | 71 | 111 | 232 | |
| 1,600 | NA | NA | NA | 13 | 18 | 38 | 68 | 108 | 224 | |
| 1,700 | NA | NA | NA | 12 | 17 | 37 | 66 | 104 | 217 | |
| 1,800 | NA | NA | NA | 12 | 17 | 36 | 64 | 101 | 210 | |
| 1,900 | NA | NA | NA | 11 | 16 | 35 | 62 | 98 | 204 | |
| 2,000 | NA | NA | NA | 11 | 16 | 34 | 60 | 95 | 199 | |

NA: A flow of less than 10 cfh.

Note: All table entries are rounded to 3 significant digits.

*Table capacities are based on Type K copper tubing inside diameter (shown), which has the smallest inside diameter of the copper tubing products.

Table 6.2.1(j) Semirigid Copper Tubing

| | | Gas: Natural | | | | | | | | |
|---------------------------------------------------------------------------|--------|----------------------------------------|-------|-------|-------|-------|-------|-------|-------|-------|
| | | Inlet Pressure: Less than 2 psi | | | | | | | | |
| | | Pressure Drop: 1.0 in. w.c. | | | | | | | | |
| | | Specific Gravity: 0.60 | | | | | | | | |
| INTENDED USE: Tube Sizing Between House Line Regulator and the Appliance. | | | | | | | | | | |
| Tube Size (in.) | | | | | | | | | | |
| Nominal: | K & L: | ¼ | ⅜ | ½ | ⅝ | ¾ | 1 | 1¼ | 1½ | 2 |
| | ACR: | ⅜ | ½ | ⅝ | ¾ | ⅞ | 1⅛ | 1⅜ | — | — |
| Outside: | | 0.375 | 0.500 | 0.625 | 0.750 | 0.875 | 1.125 | 1.375 | 1.625 | 2.125 |
| Inside:* | | 0.305 | 0.402 | 0.527 | 0.652 | 0.745 | 0.995 | 1.245 | 1.481 | 1.959 |
| Length (ft) | | Capacity in Cubic Feet of Gas per Hour | | | | | | | | |
| 10 | 39 | 80 | 162 | 283 | 402 | 859 | 1,550 | 2,440 | 5,080 | |
| 20 | 27 | 55 | 111 | 195 | 276 | 590 | 1,060 | 1,680 | 3,490 | |
| 30 | 21 | 44 | 89 | 156 | 222 | 474 | 853 | 1,350 | 2,800 | |
| 40 | 18 | 38 | 77 | 134 | 190 | 406 | 730 | 1,150 | 2,400 | |
| 50 | 16 | 33 | 68 | 119 | 168 | 359 | 647 | 1,020 | 2,130 | |
| 60 | 15 | 30 | 61 | 107 | 152 | 326 | 586 | 925 | 1,930 | |
| 70 | 13 | 28 | 57 | 99 | 140 | 300 | 539 | 851 | 1,770 | |
| 80 | 13 | 26 | 53 | 92 | 131 | 279 | 502 | 791 | 1,650 | |
| 90 | 12 | 24 | 49 | 86 | 122 | 262 | 471 | 742 | 1,550 | |
| 100 | 11 | 23 | 47 | 82 | 116 | 247 | 445 | 701 | 1,460 | |
| 125 | NA | 20 | 41 | 72 | 103 | 219 | 394 | 622 | 1,290 | |
| 150 | NA | 18 | 37 | 65 | 93 | 198 | 357 | 563 | 1,170 | |
| 175 | NA | 17 | 34 | 60 | 85 | 183 | 329 | 518 | 1,080 | |
| 200 | NA | 16 | 32 | 56 | 79 | 170 | 306 | 482 | 1,000 | |
| 250 | NA | 14 | 28 | 50 | 70 | 151 | 271 | 427 | 890 | |
| 300 | NA | 13 | 26 | 45 | 64 | 136 | 245 | 387 | 806 | |
| 350 | NA | 12 | 24 | 41 | 59 | 125 | 226 | 356 | 742 | |
| 400 | NA | 11 | 22 | 39 | 55 | 117 | 210 | 331 | 690 | |
| 450 | NA | 10 | 21 | 36 | 51 | 110 | 197 | 311 | 647 | |
| 500 | NA | NA | 20 | 34 | 48 | 103 | 186 | 294 | 612 | |
| 550 | NA | NA | 19 | 32 | 46 | 98 | 177 | 279 | 581 | |
| 600 | NA | NA | 18 | 31 | 44 | 94 | 169 | 266 | 554 | |
| 650 | NA | NA | 17 | 30 | 42 | 90 | 162 | 255 | 531 | |
| 700 | NA | NA | 16 | 28 | 40 | 86 | 155 | 245 | 510 | |
| 750 | NA | NA | 16 | 27 | 39 | 83 | 150 | 236 | 491 | |
| 800 | NA | NA | 15 | 26 | 38 | 80 | 144 | 228 | 474 | |
| 850 | NA | NA | 15 | 26 | 36 | 78 | 140 | 220 | 459 | |
| 900 | NA | NA | 14 | 25 | 35 | 75 | 135 | 214 | 445 | |
| 950 | NA | NA | 14 | 24 | 34 | 73 | 132 | 207 | 432 | |
| 1,000 | NA | NA | 13 | 23 | 33 | 71 | 128 | 202 | 420 | |
| 1,100 | NA | NA | 13 | 22 | 32 | 68 | 122 | 192 | 399 | |
| 1,200 | NA | NA | 12 | 21 | 30 | 64 | 116 | 183 | 381 | |
| 1,300 | NA | NA | 12 | 20 | 29 | 62 | 111 | 175 | 365 | |
| 1,400 | NA | NA | 11 | 20 | 28 | 59 | 107 | 168 | 350 | |
| 1,500 | NA | NA | 11 | 19 | 27 | 57 | 103 | 162 | 338 | |
| 1,600 | NA | NA | 10 | 18 | 26 | 55 | 99 | 156 | 326 | |
| 1,700 | NA | NA | 10 | 18 | 25 | 53 | 96 | 151 | 315 | |
| 1,800 | NA | NA | NA | 17 | 24 | 52 | 93 | 147 | 306 | |
| 1,900 | NA | NA | NA | 17 | 24 | 50 | 90 | 143 | 297 | |
| 2,000 | NA | NA | NA | 16 | 23 | 49 | 88 | 139 | 289 | |

NA: A flow of less than 10 cfh.

Note: All table entries are rounded to 3 significant digits.

*Table capacities are based on Type K copper tubing inside diameter (shown), which has the smallest inside diameter of the copper tubing products.

Table 6.2.1(k) Semirigid Copper Tubing

| | | Gas: Natural | | | | | | | | |
|-------------|--------|----------------------------------------|-------|-------|-------|-------|-------|--------|--------|-------|
| | | Inlet Pressure: Less than 2.0 psi | | | | | | | | |
| | | Pressure Drop: 17.0 in. w.c. | | | | | | | | |
| | | Specific Gravity: 0.60 | | | | | | | | |
| | | Tube Size (in.) | | | | | | | | |
| Nominal: | K & L: | ¼ | ⅜ | ½ | ⅝ | ¾ | 1 | 1¼ | 1½ | 2 |
| | ACR: | ⅜ | ½ | ⅝ | ¾ | ⅞ | 1⅛ | 1⅜ | — | — |
| Outside: | | 0.375 | 0.500 | 0.625 | 0.750 | 0.875 | 1.125 | 1.375 | 1.625 | 2.125 |
| Inside:* | | 0.305 | 0.402 | 0.527 | 0.652 | 0.745 | 0.995 | 1.245 | 1.481 | 1.959 |
| Length (ft) | | Capacity in Cubic Feet of Gas per Hour | | | | | | | | |
| 10 | 190 | 391 | 796 | 1,390 | 1,970 | 4,220 | 7,590 | 12,000 | 24,900 | |
| 20 | 130 | 269 | 547 | 956 | 1,360 | 2,900 | 5,220 | 8,230 | 17,100 | |
| 30 | 105 | 216 | 439 | 768 | 1,090 | 2,330 | 4,190 | 6,610 | 13,800 | |
| 40 | 90 | 185 | 376 | 657 | 932 | 1,990 | 3,590 | 5,650 | 11,800 | |
| 50 | 79 | 164 | 333 | 582 | 826 | 1,770 | 3,180 | 5,010 | 10,400 | |
| 60 | 72 | 148 | 302 | 528 | 749 | 1,600 | 2,880 | 4,540 | 9,460 | |
| 70 | 66 | 137 | 278 | 486 | 689 | 1,470 | 2,650 | 4,180 | 8,700 | |
| 80 | 62 | 127 | 258 | 452 | 641 | 1,370 | 2,460 | 3,890 | 8,090 | |
| 90 | 58 | 119 | 243 | 424 | 601 | 1,280 | 2,310 | 3,650 | 7,590 | |
| 100 | 55 | 113 | 229 | 400 | 568 | 1,210 | 2,180 | 3,440 | 7,170 | |
| 125 | 48 | 100 | 203 | 355 | 503 | 1,080 | 1,940 | 3,050 | 6,360 | |
| 150 | 44 | 90 | 184 | 321 | 456 | 974 | 1,750 | 2,770 | 5,760 | |
| 175 | 40 | 83 | 169 | 296 | 420 | 896 | 1,610 | 2,540 | 5,300 | |
| 200 | 38 | 77 | 157 | 275 | 390 | 834 | 1,500 | 2,370 | 4,930 | |
| 250 | 33 | 69 | 140 | 244 | 346 | 739 | 1,330 | 2,100 | 4,370 | |
| 300 | 30 | 62 | 126 | 221 | 313 | 670 | 1,210 | 1,900 | 3,960 | |
| 350 | 28 | 57 | 116 | 203 | 288 | 616 | 1,110 | 1,750 | 3,640 | |
| 400 | 26 | 53 | 108 | 189 | 268 | 573 | 1,030 | 1,630 | 3,390 | |
| 450 | 24 | 50 | 102 | 177 | 252 | 538 | 968 | 1,530 | 3,180 | |
| 500 | 23 | 47 | 96 | 168 | 238 | 508 | 914 | 1,440 | 3,000 | |
| 550 | 22 | 45 | 91 | 159 | 226 | 482 | 868 | 1,370 | 2,850 | |
| 600 | 21 | 43 | 87 | 152 | 215 | 460 | 829 | 1,310 | 2,720 | |
| 650 | 20 | 41 | 83 | 145 | 206 | 441 | 793 | 1,250 | 2,610 | |
| 700 | 19 | 39 | 80 | 140 | 198 | 423 | 762 | 1,200 | 2,500 | |
| 750 | 18 | 38 | 77 | 135 | 191 | 408 | 734 | 1,160 | 2,410 | |
| 800 | 18 | 37 | 74 | 130 | 184 | 394 | 709 | 1,120 | 2,330 | |
| 850 | 17 | 35 | 72 | 126 | 178 | 381 | 686 | 1,080 | 2,250 | |
| 900 | 17 | 34 | 70 | 122 | 173 | 370 | 665 | 1,050 | 2,180 | |
| 950 | 16 | 33 | 68 | 118 | 168 | 359 | 646 | 1,020 | 2,120 | |
| 1,000 | 16 | 32 | 66 | 115 | 163 | 349 | 628 | 991 | 2,060 | |
| 1,100 | 15 | 31 | 63 | 109 | 155 | 332 | 597 | 941 | 1,960 | |
| 1,200 | 14 | 29 | 60 | 104 | 148 | 316 | 569 | 898 | 1,870 | |
| 1,300 | 14 | 28 | 57 | 100 | 142 | 303 | 545 | 860 | 1,790 | |
| 1,400 | 13 | 27 | 55 | 96 | 136 | 291 | 524 | 826 | 1,720 | |
| 1,500 | 13 | 26 | 53 | 93 | 131 | 280 | 505 | 796 | 1,660 | |
| 1,600 | 12 | 25 | 51 | 89 | 127 | 271 | 487 | 768 | 1,600 | |
| 1,700 | 12 | 24 | 49 | 86 | 123 | 262 | 472 | 744 | 1,550 | |
| 1,800 | 11 | 24 | 48 | 84 | 119 | 254 | 457 | 721 | 1,500 | |
| 1,900 | 11 | 23 | 47 | 81 | 115 | 247 | 444 | 700 | 1,460 | |
| 2,000 | 11 | 22 | 45 | 79 | 112 | 240 | 432 | 681 | 1,420 | |

Note: All table entries are rounded to 3 significant digits.

*Table capacities are based on Type K copper tubing inside diameter (shown), which has the smallest inside diameter of the copper tubing products.

Table 6.2.1(l) Semirigid Copper Tubing

| | | Gas: Natural | | | | | | | | |
|--------------------|-------------------|-----------------------------------------------|--------------|--------------|--------------|--------------|--------------|--------------|--------------|--------------|
| | | Inlet Pressure: 2.0 psi | | | | | | | | |
| | | Pressure Drop: 1.0 psi | | | | | | | | |
| | | Specific Gravity: 0.60 | | | | | | | | |
| | | Tube Size (in.) | | | | | | | | |
| Nominal: | K & L: | ¼ | ⅜ | ½ | ⅝ | ¾ | 1 | 1¼ | 1½ | 2 |
| | ACR: | ⅜ | ½ | ⅝ | ¾ | ⅞ | 1⅛ | 1⅜ | — | — |
| Outside: | | 0.375 | 0.500 | 0.625 | 0.750 | 0.875 | 1.125 | 1.375 | 1.625 | 2.125 |
| Inside:* | | 0.305 | 0.402 | 0.527 | 0.652 | 0.745 | 0.995 | 1.245 | 1.481 | 1.959 |
| Length (ft) | | Capacity in Cubic Feet of Gas per Hour | | | | | | | | |
| 10 | 245 | 506 | 1,030 | 1,800 | 2,550 | 5,450 | 9,820 | 15,500 | 32,200 | |
| 20 | 169 | 348 | 708 | 1,240 | 1,760 | 3,750 | 6,750 | 10,600 | 22,200 | |
| 30 | 135 | 279 | 568 | 993 | 1,410 | 3,010 | 5,420 | 8,550 | 17,800 | |
| 40 | 116 | 239 | 486 | 850 | 1,210 | 2,580 | 4,640 | 7,310 | 15,200 | |
| 50 | 103 | 212 | 431 | 754 | 1,070 | 2,280 | 4,110 | 6,480 | 13,500 | |
| 60 | 93 | 192 | 391 | 683 | 969 | 2,070 | 3,730 | 5,870 | 12,200 | |
| 70 | 86 | 177 | 359 | 628 | 891 | 1,900 | 3,430 | 5,400 | 11,300 | |
| 80 | 80 | 164 | 334 | 584 | 829 | 1,770 | 3,190 | 5,030 | 10,500 | |
| 90 | 75 | 154 | 314 | 548 | 778 | 1,660 | 2,990 | 4,720 | 9,820 | |
| 100 | 71 | 146 | 296 | 518 | 735 | 1,570 | 2,830 | 4,450 | 9,280 | |
| 125 | 63 | 129 | 263 | 459 | 651 | 1,390 | 2,500 | 3,950 | 8,220 | |
| 150 | 57 | 117 | 238 | 416 | 590 | 1,260 | 2,270 | 3,580 | 7,450 | |
| 175 | 52 | 108 | 219 | 383 | 543 | 1,160 | 2,090 | 3,290 | 6,850 | |
| 200 | 49 | 100 | 204 | 356 | 505 | 1,080 | 1,940 | 3,060 | 6,380 | |
| 250 | 43 | 89 | 181 | 315 | 448 | 956 | 1,720 | 2,710 | 5,650 | |
| 300 | 39 | 80 | 164 | 286 | 406 | 866 | 1,560 | 2,460 | 5,120 | |
| 350 | 36 | 74 | 150 | 263 | 373 | 797 | 1,430 | 2,260 | 4,710 | |
| 400 | 33 | 69 | 140 | 245 | 347 | 741 | 1,330 | 2,100 | 4,380 | |
| 450 | 31 | 65 | 131 | 230 | 326 | 696 | 1,250 | 1,970 | 4,110 | |
| 500 | 30 | 61 | 124 | 217 | 308 | 657 | 1,180 | 1,870 | 3,880 | |
| 550 | 28 | 58 | 118 | 206 | 292 | 624 | 1,120 | 1,770 | 3,690 | |
| 600 | 27 | 55 | 112 | 196 | 279 | 595 | 1,070 | 1,690 | 3,520 | |
| 650 | 26 | 53 | 108 | 188 | 267 | 570 | 1,030 | 1,620 | 3,370 | |
| 700 | 25 | 51 | 103 | 181 | 256 | 548 | 986 | 1,550 | 3,240 | |
| 750 | 24 | 49 | 100 | 174 | 247 | 528 | 950 | 1,500 | 3,120 | |
| 800 | 23 | 47 | 96 | 168 | 239 | 510 | 917 | 1,450 | 3,010 | |
| 850 | 22 | 46 | 93 | 163 | 231 | 493 | 888 | 1,400 | 2,920 | |
| 900 | 22 | 44 | 90 | 158 | 224 | 478 | 861 | 1,360 | 2,830 | |
| 950 | 21 | 43 | 88 | 153 | 217 | 464 | 836 | 1,320 | 2,740 | |
| 1,000 | 20 | 42 | 85 | 149 | 211 | 452 | 813 | 1,280 | 2,670 | |
| 1,100 | 19 | 40 | 81 | 142 | 201 | 429 | 772 | 1,220 | 2,540 | |
| 1,200 | 18 | 38 | 77 | 135 | 192 | 409 | 737 | 1,160 | 2,420 | |
| 1,300 | 18 | 36 | 74 | 129 | 183 | 392 | 705 | 1,110 | 2,320 | |
| 1,400 | 17 | 35 | 71 | 124 | 176 | 376 | 678 | 1,070 | 2,230 | |
| 1,500 | 16 | 34 | 68 | 120 | 170 | 363 | 653 | 1,030 | 2,140 | |
| 1,600 | 16 | 33 | 66 | 116 | 164 | 350 | 630 | 994 | 2,070 | |
| 1,700 | 15 | 31 | 64 | 112 | 159 | 339 | 610 | 962 | 2,000 | |
| 1,800 | 15 | 30 | 62 | 108 | 154 | 329 | 592 | 933 | 1,940 | |
| 1,900 | 14 | 30 | 60 | 105 | 149 | 319 | 575 | 906 | 1,890 | |
| 2,000 | 14 | 29 | 59 | 102 | 145 | 310 | 559 | 881 | 1,830 | |

Note: All table entries are rounded to 3 significant digits.

*Table capacities are based on Type K copper tubing inside diameter (shown), which has the smallest inside diameter of the copper tubing products.

Table 6.2.1(m) Semirigid Copper Tubing

| | | Gas: Natural | | | | | | | | |
|--------------------------------------------------------------------------------------------------------------------------------------------------------------------------------|--------|----------------------------------------|-------|-------|-------|-------|--------|--------|--------|-------|
| | | Inlet Pressure: 2.0 psi | | | | | | | | |
| | | Pressure Drop: 1.5 psi | | | | | | | | |
| | | Specific Gravity: 0.60 | | | | | | | | |
| INTENDED USE: Pipe Sizing Between Point of Delivery and the House Line Regulator. Total Load Supplied by a Single House Line Regulator Not Exceeding 150 Cubic Feet per Hour.* | | | | | | | | | | |
| | | Tube Size (in.) | | | | | | | | |
| Nominal: | K & L: | ¼ | ⅜ | ½ | ⅝ | ¾ | 1 | 1¼ | 1½ | 2 |
| | ACR: | ⅜ | ½ | ⅝ | ¾ | ⅞ | 1⅛ | 1⅜ | — | — |
| Outside: | | 0.375 | 0.500 | 0.625 | 0.750 | 0.875 | 1.125 | 1.375 | 1.625 | 2.125 |
| Inside:† | | 0.305 | 0.402 | 0.527 | 0.652 | 0.745 | 0.995 | 1.245 | 1.481 | 1.959 |
| Length (ft) | | Capacity in Cubic Feet of Gas per Hour | | | | | | | | |
| 10 | 303 | 625 | 1,270 | 2,220 | 3,150 | 6,740 | 12,100 | 19,100 | 39,800 | |
| 20 | 208 | 430 | 874 | 1,530 | 2,170 | 4,630 | 8,330 | 13,100 | 27,400 | |
| 30 | 167 | 345 | 702 | 1,230 | 1,740 | 3,720 | 6,690 | 10,600 | 22,000 | |
| 40 | 143 | 295 | 601 | 1,050 | 1,490 | 3,180 | 5,730 | 9,030 | 18,800 | |
| 50 | 127 | 262 | 532 | 931 | 1,320 | 2,820 | 5,080 | 8,000 | 16,700 | |
| 60 | 115 | 237 | 482 | 843 | 1,200 | 2,560 | 4,600 | 7,250 | 15,100 | |
| 70 | 106 | 218 | 444 | 776 | 1,100 | 2,350 | 4,230 | 6,670 | 13,900 | |
| 80 | 98 | 203 | 413 | 722 | 1,020 | 2,190 | 3,940 | 6,210 | 12,900 | |
| 90 | 92 | 190 | 387 | 677 | 961 | 2,050 | 3,690 | 5,820 | 12,100 | |
| 100 | 87 | 180 | 366 | 640 | 907 | 1,940 | 3,490 | 5,500 | 11,500 | |
| 125 | 77 | 159 | 324 | 567 | 804 | 1,720 | 3,090 | 4,880 | 10,200 | |
| 150 | 70 | 144 | 294 | 514 | 729 | 1,560 | 2,800 | 4,420 | 9,200 | |
| 175 | 64 | 133 | 270 | 472 | 670 | 1,430 | 2,580 | 4,060 | 8,460 | |
| 200 | 60 | 124 | 252 | 440 | 624 | 1,330 | 2,400 | 3,780 | 7,870 | |
| 250 | 53 | 110 | 223 | 390 | 553 | 1,180 | 2,130 | 3,350 | 6,980 | |
| 300 | 48 | 99 | 202 | 353 | 501 | 1,070 | 1,930 | 3,040 | 6,320 | |
| 350 | 44 | 91 | 186 | 325 | 461 | 984 | 1,770 | 2,790 | 5,820 | |
| 400 | 41 | 85 | 173 | 302 | 429 | 916 | 1,650 | 2,600 | 5,410 | |
| 450 | 39 | 80 | 162 | 283 | 402 | 859 | 1,550 | 2,440 | 5,080 | |
| 500 | 36 | 75 | 153 | 268 | 380 | 811 | 1,460 | 2,300 | 4,800 | |
| 550 | 35 | 72 | 146 | 254 | 361 | 771 | 1,390 | 2,190 | 4,560 | |
| 600 | 33 | 68 | 139 | 243 | 344 | 735 | 1,320 | 2,090 | 4,350 | |
| 650 | 32 | 65 | 133 | 232 | 330 | 704 | 1,270 | 2,000 | 4,160 | |
| 700 | 30 | 63 | 128 | 223 | 317 | 676 | 1,220 | 1,920 | 4,000 | |
| 750 | 29 | 60 | 123 | 215 | 305 | 652 | 1,170 | 1,850 | 3,850 | |
| 800 | 28 | 58 | 119 | 208 | 295 | 629 | 1,130 | 1,790 | 3,720 | |
| 850 | 27 | 57 | 115 | 201 | 285 | 609 | 1,100 | 1,730 | 3,600 | |
| 900 | 27 | 55 | 111 | 195 | 276 | 590 | 1,060 | 1,680 | 3,490 | |
| 950 | 26 | 53 | 108 | 189 | 268 | 573 | 1,030 | 1,630 | 3,390 | |
| 1,000 | 25 | 52 | 105 | 184 | 261 | 558 | 1,000 | 1,580 | 3,300 | |
| 1,100 | 24 | 49 | 100 | 175 | 248 | 530 | 954 | 1,500 | 3,130 | |
| 1,200 | 23 | 47 | 95 | 167 | 237 | 505 | 910 | 1,430 | 2,990 | |
| 1,300 | 22 | 45 | 91 | 160 | 227 | 484 | 871 | 1,370 | 2,860 | |
| 1,400 | 21 | 43 | 88 | 153 | 218 | 465 | 837 | 1,320 | 2,750 | |
| 1,500 | 20 | 42 | 85 | 148 | 210 | 448 | 806 | 1,270 | 2,650 | |
| 1,600 | 19 | 40 | 82 | 143 | 202 | 432 | 779 | 1,230 | 2,560 | |
| 1,700 | 19 | 39 | 79 | 138 | 196 | 419 | 753 | 1,190 | 2,470 | |
| 1,800 | 18 | 38 | 77 | 134 | 190 | 406 | 731 | 1,150 | 2,400 | |
| 1,900 | 18 | 37 | 74 | 130 | 184 | 394 | 709 | 1,120 | 2,330 | |
| 2,000 | 17 | 36 | 72 | 126 | 179 | 383 | 690 | 1,090 | 2,270 | |

Note: All table entries are rounded to 3 significant digits.

*When this table is used to size the tubing upstream of a line pressure regulator, the pipe or tubing downstream of the line pressure regulator shall be sized using a pressure drop no greater than 1 in. w.c.

†Table capacities are based on Type K copper tubing inside diameter (shown), which has the smallest inside diameter of the copper tubing products.

Table 6.2.1(n) Semirigid Copper Tubing

| | | Gas: Natural | | | | | | | | |
|-------------|--------|----------------------------------------|-------|-------|-------|--------|--------|--------|--------|-------|
| | | Inlet Pressure: 5.0 psi | | | | | | | | |
| | | Pressure Drop: 3.5 psi | | | | | | | | |
| | | Specific Gravity: 0.60 | | | | | | | | |
| | | Tube Size (in.) | | | | | | | | |
| Nominal: | K & L: | ¼ | ⅜ | ½ | ⅝ | ¾ | 1 | 1¼ | 1½ | 2 |
| | ACR: | ⅜ | ½ | ⅝ | ¾ | ⅞ | 1⅛ | 1⅜ | — | — |
| Outside: | | 0.375 | 0.500 | 0.625 | 0.750 | 0.875 | 1.125 | 1.375 | 1.625 | 2.125 |
| Inside*: | | 0.305 | 0.402 | 0.527 | 0.652 | 0.745 | 0.995 | 1.245 | 1.481 | 1.959 |
| Length (ft) | | Capacity in Cubic Feet of Gas per Hour | | | | | | | | |
| 10 | 511 | 1,050 | 2,140 | 3,750 | 5,320 | 11,400 | 20,400 | 32,200 | 67,100 | |
| 20 | 351 | 724 | 1,470 | 2,580 | 3,650 | 7,800 | 14,000 | 22,200 | 46,100 | |
| 30 | 282 | 582 | 1,180 | 2,070 | 2,930 | 6,270 | 11,300 | 17,800 | 37,000 | |
| 40 | 241 | 498 | 1,010 | 1,770 | 2,510 | 5,360 | 9,660 | 15,200 | 31,700 | |
| 50 | 214 | 441 | 898 | 1,570 | 2,230 | 4,750 | 8,560 | 13,500 | 28,100 | |
| 60 | 194 | 400 | 813 | 1,420 | 2,020 | 4,310 | 7,750 | 12,200 | 25,500 | |
| 70 | 178 | 368 | 748 | 1,310 | 1,860 | 3,960 | 7,130 | 11,200 | 23,400 | |
| 80 | 166 | 342 | 696 | 1,220 | 1,730 | 3,690 | 6,640 | 10,500 | 21,800 | |
| 90 | 156 | 321 | 653 | 1,140 | 1,620 | 3,460 | 6,230 | 9,820 | 20,400 | |
| 100 | 147 | 303 | 617 | 1,080 | 1,530 | 3,270 | 5,880 | 9,270 | 19,300 | |
| 125 | 130 | 269 | 547 | 955 | 1,360 | 2,900 | 5,210 | 8,220 | 17,100 | |
| 150 | 118 | 243 | 495 | 866 | 1,230 | 2,620 | 4,720 | 7,450 | 15,500 | |
| 175 | 109 | 224 | 456 | 796 | 1,130 | 2,410 | 4,350 | 6,850 | 14,300 | |
| 200 | 101 | 208 | 424 | 741 | 1,050 | 2,250 | 4,040 | 6,370 | 13,300 | |
| 250 | 90 | 185 | 376 | 657 | 932 | 1,990 | 3,580 | 5,650 | 11,800 | |
| 300 | 81 | 167 | 340 | 595 | 844 | 1,800 | 3,250 | 5,120 | 10,700 | |
| 350 | 75 | 154 | 313 | 547 | 777 | 1,660 | 2,990 | 4,710 | 9,810 | |
| 400 | 69 | 143 | 291 | 509 | 722 | 1,540 | 2,780 | 4,380 | 9,120 | |
| 450 | 65 | 134 | 273 | 478 | 678 | 1,450 | 2,610 | 4,110 | 8,560 | |
| 500 | 62 | 127 | 258 | 451 | 640 | 1,370 | 2,460 | 3,880 | 8,090 | |
| 550 | 58 | 121 | 245 | 429 | 608 | 1,300 | 2,340 | 3,690 | 7,680 | |
| 600 | 56 | 115 | 234 | 409 | 580 | 1,240 | 2,230 | 3,520 | 7,330 | |
| 650 | 53 | 110 | 224 | 392 | 556 | 1,190 | 2,140 | 3,370 | 7,020 | |
| 700 | 51 | 106 | 215 | 376 | 534 | 1,140 | 2,050 | 3,240 | 6,740 | |
| 750 | 49 | 102 | 207 | 362 | 514 | 1,100 | 1,980 | 3,120 | 6,490 | |
| 800 | 48 | 98 | 200 | 350 | 497 | 1,060 | 1,910 | 3,010 | 6,270 | |
| 850 | 46 | 95 | 194 | 339 | 481 | 1,030 | 1,850 | 2,910 | 6,070 | |
| 900 | 45 | 92 | 188 | 328 | 466 | 1,000 | 1,790 | 2,820 | 5,880 | |
| 950 | 43 | 90 | 182 | 319 | 452 | 967 | 1,740 | 2,740 | 5,710 | |
| 1,000 | 42 | 87 | 177 | 310 | 440 | 940 | 1,690 | 2,670 | 5,560 | |
| 1,100 | 40 | 83 | 169 | 295 | 418 | 893 | 1,610 | 2,530 | 5,280 | |
| 1,200 | 38 | 79 | 161 | 281 | 399 | 852 | 1,530 | 2,420 | 5,040 | |
| 1,300 | 37 | 76 | 154 | 269 | 382 | 816 | 1,470 | 2,320 | 4,820 | |
| 1,400 | 35 | 73 | 148 | 259 | 367 | 784 | 1,410 | 2,220 | 4,630 | |
| 1,500 | 34 | 70 | 143 | 249 | 353 | 755 | 1,360 | 2,140 | 4,460 | |
| 1,600 | 33 | 68 | 138 | 241 | 341 | 729 | 1,310 | 2,070 | 4,310 | |
| 1,700 | 32 | 65 | 133 | 233 | 330 | 705 | 1,270 | 2,000 | 4,170 | |
| 1,800 | 31 | 63 | 129 | 226 | 320 | 684 | 1,230 | 1,940 | 4,040 | |
| 1,900 | 30 | 62 | 125 | 219 | 311 | 664 | 1,200 | 1,890 | 3,930 | |
| 2,000 | 29 | 60 | 122 | 213 | 302 | 646 | 1,160 | 1,830 | 3,820 | |

Note: All table entries are rounded to 3 significant digits.

*Table capacities are based on Type K copper tubing inside diameter (shown), which has the smallest inside diameter of the copper tubing products.

Table 6.2.1(o) Corrugated Stainless Steel Tubing (CSST)

| | | | | | | | | | | | | | | Gas: Natural | | | | | | | | | | | | | |
|--------------------------|-----------------------------------------------|-----------|-----------|-----------|-----------|-----------|-----------|-----------|-----------|-----------|-----------|-----------|-----------|----------------------------------------|--|--|--|--|--|--|--|--|--|--|--|--|--|
| | | | | | | | | | | | | | | Inlet Pressure: Less than 2 psi | | | | | | | | | | | | | |
| | | | | | | | | | | | | | | Pressure Drop: 0.5 in. w.c. | | | | | | | | | | | | | |
| | | | | | | | | | | | | | | Specific Gravity: 0.60 | | | | | | | | | | | | | |
| | | | | | | | | | | | | | | Tube Size (EHD) | | | | | | | | | | | | | |
| Flow Designation: | 13 | 15 | 18 | 19 | 23 | 25 | 30 | 31 | 37 | 39 | 46 | 48 | 60 | 62 | | | | | | | | | | | | | |
| Length (ft) | Capacity in Cubic Feet of Gas per Hour | | | | | | | | | | | | | | | | | | | | | | | | | | |
| 5 | 46 | 63 | 115 | 134 | 225 | 270 | 471 | 546 | 895 | 1,037 | 1,790 | 2,070 | 3,660 | 4,140 | | | | | | | | | | | | | |
| 10 | 32 | 44 | 82 | 95 | 161 | 192 | 330 | 383 | 639 | 746 | 1,260 | 1,470 | 2,600 | 2,930 | | | | | | | | | | | | | |
| 15 | 25 | 35 | 66 | 77 | 132 | 157 | 267 | 310 | 524 | 615 | 1,030 | 1,200 | 2,140 | 2,400 | | | | | | | | | | | | | |
| 20 | 22 | 31 | 58 | 67 | 116 | 137 | 231 | 269 | 456 | 536 | 888 | 1,050 | 1,850 | 2,080 | | | | | | | | | | | | | |
| 25 | 19 | 27 | 52 | 60 | 104 | 122 | 206 | 240 | 409 | 482 | 793 | 936 | 1,660 | 1,860 | | | | | | | | | | | | | |
| 30 | 18 | 25 | 47 | 55 | 96 | 112 | 188 | 218 | 374 | 442 | 723 | 856 | 1,520 | 1,700 | | | | | | | | | | | | | |
| 40 | 15 | 21 | 41 | 47 | 83 | 97 | 162 | 188 | 325 | 386 | 625 | 742 | 1,320 | 1,470 | | | | | | | | | | | | | |
| 50 | 13 | 19 | 37 | 42 | 75 | 87 | 144 | 168 | 292 | 347 | 559 | 665 | 1,180 | 1,320 | | | | | | | | | | | | | |
| 60 | 12 | 17 | 34 | 38 | 68 | 80 | 131 | 153 | 267 | 318 | 509 | 608 | 1,080 | 1,200 | | | | | | | | | | | | | |
| 70 | 11 | 16 | 31 | 36 | 63 | 74 | 121 | 141 | 248 | 295 | 471 | 563 | 1,000 | 1,110 | | | | | | | | | | | | | |
| 80 | 10 | 15 | 29 | 33 | 60 | 69 | 113 | 132 | 232 | 277 | 440 | 527 | 940 | 1,040 | | | | | | | | | | | | | |
| 90 | 10 | 14 | 28 | 32 | 57 | 65 | 107 | 125 | 219 | 262 | 415 | 498 | 887 | 983 | | | | | | | | | | | | | |
| 100 | 9 | 13 | 26 | 30 | 54 | 62 | 101 | 118 | 208 | 249 | 393 | 472 | 843 | 933 | | | | | | | | | | | | | |
| 150 | 7 | 10 | 20 | 23 | 42 | 48 | 78 | 91 | 171 | 205 | 320 | 387 | 691 | 762 | | | | | | | | | | | | | |
| 200 | 6 | 9 | 18 | 21 | 38 | 44 | 71 | 82 | 148 | 179 | 277 | 336 | 600 | 661 | | | | | | | | | | | | | |
| 250 | 5 | 8 | 16 | 19 | 34 | 39 | 63 | 74 | 133 | 161 | 247 | 301 | 538 | 591 | | | | | | | | | | | | | |
| 300 | 5 | 7 | 15 | 17 | 32 | 36 | 57 | 67 | 95 | 148 | 226 | 275 | 492 | 540 | | | | | | | | | | | | | |

EHD: Equivalent hydraulic diameter. A measure of the relative hydraulic efficiency between different tubing sizes. The greater the value of EHD, the greater the gas capacity of the tubing.

- Notes:
- (1) Table includes losses for four 90 degree bends and two end fittings. Tubing runs with larger numbers of bends and/or fittings shall be increased by an equivalent length of tubing to the following equation: $L = 1.3n$, where L is additional length (ft) of tubing and n is the number of additional fittings and/or bends.
 - (2) All table entries are rounded to 3 significant digits.

Table 6.2.1(p) Corrugated Stainless Steel Tubing (CSST)

| | | | | | | | | | | | | | | Gas: | Natural |
|-------------------------------------------------------------------|----------------------------------------|-----|-----|-----|-----|-----|-------|-------|-------|------|-------|-------|-------|-------------------|-----------------|
| | | | | | | | | | | | | | | Inlet Pressure: | Less than 2 psi |
| | | | | | | | | | | | | | | Pressure Drop: | 3.0 in. w.c. |
| | | | | | | | | | | | | | | Specific Gravity: | 0.60 |
| INTENDED USE: Initial Supply Pressure of 8.0 in. w.c. or Greater. | | | | | | | | | | | | | | | |
| Tube Size (EHD) | | | | | | | | | | | | | | | |
| Flow Designation: | 13 | 15 | 18 | 19 | 23 | 25 | 30 | 31 | 37 | 39 | 46 | 48 | 60 | 62 | |
| Length (ft) | Capacity in Cubic Feet of Gas per Hour | | | | | | | | | | | | | | |
| 5 | 120 | 160 | 277 | 327 | 529 | 649 | 1,180 | 1,370 | 2,140 | 2423 | 4,430 | 5,010 | 8,800 | 10,100 | |
| 10 | 83 | 112 | 197 | 231 | 380 | 462 | 828 | 958 | 1,530 | 1740 | 3,200 | 3,560 | 6,270 | 7,160 | |
| 15 | 67 | 90 | 161 | 189 | 313 | 379 | 673 | 778 | 1,250 | 1433 | 2,540 | 2,910 | 5,140 | 5,850 | |
| 20 | 57 | 78 | 140 | 164 | 273 | 329 | 580 | 672 | 1,090 | 1249 | 2,200 | 2,530 | 4,460 | 5,070 | |
| 25 | 51 | 69 | 125 | 147 | 245 | 295 | 518 | 599 | 978 | 1123 | 1,960 | 2,270 | 4,000 | 4,540 | |
| 30 | 46 | 63 | 115 | 134 | 225 | 270 | 471 | 546 | 895 | 1029 | 1,790 | 2,070 | 3,660 | 4,140 | |
| 40 | 39 | 54 | 100 | 116 | 196 | 234 | 407 | 471 | 778 | 897 | 1,550 | 1,800 | 3,180 | 3,590 | |
| 50 | 35 | 48 | 89 | 104 | 176 | 210 | 363 | 421 | 698 | 806 | 1,380 | 1,610 | 2,850 | 3,210 | |
| 60 | 32 | 44 | 82 | 95 | 161 | 192 | 330 | 383 | 639 | 739 | 1,260 | 1,470 | 2,600 | 2,930 | |
| 70 | 29 | 41 | 76 | 88 | 150 | 178 | 306 | 355 | 593 | 686 | 1,170 | 1,360 | 2,420 | 2,720 | |
| 80 | 27 | 38 | 71 | 82 | 141 | 167 | 285 | 331 | 555 | 644 | 1,090 | 1,280 | 2,260 | 2,540 | |
| 90 | 26 | 36 | 67 | 77 | 133 | 157 | 268 | 311 | 524 | 609 | 1,030 | 1,200 | 2,140 | 2,400 | |
| 100 | 24 | 34 | 63 | 73 | 126 | 149 | 254 | 295 | 498 | 579 | 974 | 1,140 | 2,030 | 2,280 | |
| 150 | 19 | 27 | 52 | 60 | 104 | 122 | 206 | 240 | 409 | 477 | 793 | 936 | 1,660 | 1,860 | |
| 200 | 17 | 23 | 45 | 52 | 91 | 106 | 178 | 207 | 355 | 415 | 686 | 812 | 1,440 | 1,610 | |
| 250 | 15 | 21 | 40 | 46 | 82 | 95 | 159 | 184 | 319 | 373 | 613 | 728 | 1,290 | 1,440 | |
| 300 | 13 | 19 | 37 | 42 | 75 | 87 | 144 | 168 | 234 | 342 | 559 | 665 | 1,180 | 1,320 | |

EHD: Equivalent hydraulic diameter. A measure of the relative hydraulic efficiency between different tubing sizes. The greater the value of EHD, the greater the gas capacity of the tubing.

Notes:

(1) Table includes losses for four 90 degree bends and two end fittings. Tubing runs with larger numbers of bends and/or fittings shall be increased by an equivalent length of tubing to the following equation: $L = 1.3n$, where L is additional length (ft) of tubing and n is the number of additional fittings and/or bends.

(2) All table entries are rounded to 3 significant digits.

Table 6.2.1(q) Corrugated Stainless Steel Tubing (CSST)

| | | | | | | | | | | | | | | Gas: | Natural |
|--------------------------------------------------------------------|----------------------------------------|-----|-----|-----|-----|-----|-------|-------|-------|-------|-------|-------|--------|-------------------|-----------------|
| | | | | | | | | | | | | | | Inlet Pressure: | Less than 2 psi |
| | | | | | | | | | | | | | | Pressure Drop: | 6.0 in. w.c. |
| | | | | | | | | | | | | | | Specific Gravity: | 0.60 |
| INTENDED USE: Initial Supply Pressure of 11.0 in. w.c. or Greater. | | | | | | | | | | | | | | | |
| Tube Size (EHD) | | | | | | | | | | | | | | | |
| Flow Designation: | 13 | 15 | 18 | 19 | 23 | 25 | 30 | 31 | 37 | 39 | 46 | 48 | 60 | 62 | |
| Length (ft) | Capacity in Cubic Feet of Gas per Hour | | | | | | | | | | | | | | |
| 5 | 173 | 229 | 389 | 461 | 737 | 911 | 1,690 | 1,950 | 3,000 | 3,375 | 6,280 | 7,050 | 12,400 | 14,260 | |
| 10 | 120 | 160 | 277 | 327 | 529 | 649 | 1,180 | 1,370 | 2,140 | 2,423 | 4,430 | 5,010 | 8,800 | 10,100 | |
| 15 | 96 | 130 | 227 | 267 | 436 | 532 | 960 | 1,110 | 1,760 | 1,996 | 3,610 | 4,100 | 7,210 | 8,260 | |
| 20 | 83 | 112 | 197 | 231 | 380 | 462 | 828 | 958 | 1,530 | 1,740 | 3,120 | 3,560 | 6,270 | 7,160 | |
| 25 | 74 | 99 | 176 | 207 | 342 | 414 | 739 | 855 | 1,370 | 1,564 | 2,790 | 3,190 | 5,620 | 6,400 | |
| 30 | 67 | 90 | 161 | 189 | 313 | 379 | 673 | 778 | 1,250 | 1,433 | 2,540 | 2,910 | 5,140 | 5,850 | |
| 40 | 57 | 78 | 140 | 164 | 273 | 329 | 580 | 672 | 1,090 | 1,249 | 2,200 | 2,530 | 4,460 | 5,070 | |
| 50 | 51 | 69 | 125 | 147 | 245 | 295 | 518 | 599 | 978 | 1,123 | 1,960 | 2,270 | 4,000 | 4,540 | |
| 60 | 46 | 63 | 115 | 134 | 225 | 270 | 471 | 546 | 895 | 1,029 | 1,790 | 2,070 | 3,660 | 4,140 | |
| 70 | 42 | 58 | 106 | 124 | 209 | 250 | 435 | 505 | 830 | 956 | 1,660 | 1,920 | 3,390 | 3,840 | |
| 80 | 39 | 54 | 100 | 116 | 196 | 234 | 407 | 471 | 778 | 897 | 1,550 | 1,800 | 3,180 | 3,590 | |
| 90 | 37 | 51 | 94 | 109 | 185 | 221 | 383 | 444 | 735 | 848 | 1,460 | 1,700 | 3,000 | 3,390 | |
| 100 | 35 | 48 | 89 | 104 | 176 | 210 | 363 | 421 | 698 | 806 | 1,380 | 1,610 | 2,850 | 3,210 | |
| 150 | 28 | 39 | 73 | 85 | 145 | 172 | 294 | 342 | 573 | 664 | 1,130 | 1,320 | 2,340 | 2,630 | |
| 200 | 24 | 34 | 63 | 73 | 126 | 149 | 254 | 295 | 498 | 579 | 974 | 1,140 | 2,030 | 2,280 | |
| 250 | 21 | 30 | 57 | 66 | 114 | 134 | 226 | 263 | 447 | 520 | 870 | 1,020 | 1,820 | 2,040 | |
| 300 | 19 | 27 | 52 | 60 | 104 | 122 | 206 | 240 | 409 | 477 | 793 | 936 | 1,660 | 1,860 | |

EHD: Equivalent hydraulic diameter. A measure of the relative hydraulic efficiency between different tubing sizes. The greater the value of EHD, the greater the gas capacity of the tubing.

Notes:

(1) Table includes losses for four 90 degree bends and two end fittings. Tubing runs with larger numbers of bends and/or fittings shall be increased by an equivalent length of tubing to the following equation: $L = 1.3n$, where L is additional length (ft) of tubing and n is the number of additional fittings and/or bends.

(2) All table entries are rounded to 3 significant digits.

Table 6.2.1(r) Corrugated Stainless Steel Tubing (CSST)

| | | | | | | | | | | | | | | Gas: | Natural | | | | | | | | | | | | |
|-------------------|----------------------------------------|-----|-----|-----|-------|-------|-------|-------|-------|-------|-------|--------|--------|-------------------|---------|--|--|--|--|--|--|--|--|--|--|--|--|
| | | | | | | | | | | | | | | Inlet Pressure: | 2.0 psi | | | | | | | | | | | | |
| | | | | | | | | | | | | | | Pressure Drop: | 1.0 psi | | | | | | | | | | | | |
| | | | | | | | | | | | | | | Specific Gravity: | 0.60 | | | | | | | | | | | | |
| | | | | | | | | | | | | | | Tube Size (EHD) | | | | | | | | | | | | | |
| Flow Designation: | 13 | 15 | 18 | 19 | 23 | 25 | 30 | 31 | 37 | 39 | 46 | 48 | 60 | 62 | | | | | | | | | | | | | |
| Length (ft) | Capacity in Cubic Feet of Gas per Hour | | | | | | | | | | | | | | | | | | | | | | | | | | |
| 10 | 270 | 353 | 587 | 700 | 1,100 | 1,370 | 2,590 | 2,990 | 4,510 | 5,037 | 9,600 | 10,700 | 18,600 | 21,600 | | | | | | | | | | | | | |
| 25 | 166 | 220 | 374 | 444 | 709 | 876 | 1,620 | 1,870 | 2,890 | 3,258 | 6,040 | 6,780 | 11,900 | 13,700 | | | | | | | | | | | | | |
| 30 | 151 | 200 | 342 | 405 | 650 | 801 | 1,480 | 1,700 | 2,640 | 2,987 | 5,510 | 6,200 | 10,900 | 12,500 | | | | | | | | | | | | | |
| 40 | 129 | 172 | 297 | 351 | 567 | 696 | 1,270 | 1,470 | 2,300 | 2,605 | 4,760 | 5,380 | 9,440 | 10,900 | | | | | | | | | | | | | |
| 50 | 115 | 154 | 266 | 314 | 510 | 624 | 1,140 | 1,310 | 2,060 | 2,343 | 4,260 | 4,820 | 8,470 | 9,720 | | | | | | | | | | | | | |
| 75 | 93 | 124 | 218 | 257 | 420 | 512 | 922 | 1,070 | 1,690 | 1,932 | 3,470 | 3,950 | 6,940 | 7,940 | | | | | | | | | | | | | |
| 80 | 89 | 120 | 211 | 249 | 407 | 496 | 892 | 1,030 | 1,640 | 1,874 | 3,360 | 3,820 | 6,730 | 7,690 | | | | | | | | | | | | | |
| 100 | 79 | 107 | 189 | 222 | 366 | 445 | 795 | 920 | 1,470 | 1,685 | 3,000 | 3,420 | 6,030 | 6,880 | | | | | | | | | | | | | |
| 150 | 64 | 87 | 155 | 182 | 302 | 364 | 646 | 748 | 1,210 | 1,389 | 2,440 | 2,800 | 4,940 | 5,620 | | | | | | | | | | | | | |
| 200 | 55 | 75 | 135 | 157 | 263 | 317 | 557 | 645 | 1,050 | 1,212 | 2,110 | 2,430 | 4,290 | 4,870 | | | | | | | | | | | | | |
| 250 | 49 | 67 | 121 | 141 | 236 | 284 | 497 | 576 | 941 | 1,090 | 1,890 | 2,180 | 3,850 | 4,360 | | | | | | | | | | | | | |
| 300 | 44 | 61 | 110 | 129 | 217 | 260 | 453 | 525 | 862 | 999 | 1,720 | 1,990 | 3,520 | 3,980 | | | | | | | | | | | | | |
| 400 | 38 | 52 | 96 | 111 | 189 | 225 | 390 | 453 | 749 | 871 | 1,490 | 1,730 | 3,060 | 3,450 | | | | | | | | | | | | | |
| 500 | 34 | 46 | 86 | 100 | 170 | 202 | 348 | 404 | 552 | 783 | 1,330 | 1,550 | 2,740 | 3,090 | | | | | | | | | | | | | |

EHD: Equivalent hydraulic diameter. A measure of the relative hydraulic efficiency between different tubing sizes. The greater the value of EHD, the greater the gas capacity of the tubing.

Notes:

- (1) Table does not include effect of pressure drop across the line regulator. Where regulator loss exceeds $\frac{3}{4}$ psi, do not use this table. Consult with regulator manufacturer for pressure drops and capacity factors. Pressure drops across a regulator may vary with flow rate.
- (2) CAUTION: Capacities shown in table may exceed maximum capacity for a selected regulator. Consult with regulator or tubing manufacturer for guidance.
- (3) Table includes losses for four 90 degree bends and two end fittings. Tubing runs with larger number of bends and/or fittings shall be increased by an equivalent length of tubing according to the following equation: $L = 1.3n$, where L is additional length (ft) of tubing and n is the number of additional fittings and/or bends.
- (4) All table entries are rounded to 3 significant digits.

Table 6.2.1(s) Corrugated Stainless Steel Tubing (CSST)

| | | | | | | | | | | | | | | Gas: Natural | | | | | | | | | | | | | | |
|-------------------|----------------------------------------|-----|-------|-------|-------|-------|-------|-------|-------|-------|--------|--------|--------|-------------------------|--|--|--|--|--|--|--|--|--|--|--|--|--|--|
| | | | | | | | | | | | | | | Inlet Pressure: 5.0 psi | | | | | | | | | | | | | | |
| | | | | | | | | | | | | | | Pressure Drop: 3.5 psi | | | | | | | | | | | | | | |
| | | | | | | | | | | | | | | Specific Gravity: 0.60 | | | | | | | | | | | | | | |
| | | | | | | | | | | | | | | Tube Size (EHD) | | | | | | | | | | | | | | |
| Flow Designation: | 13 | 15 | 18 | 19 | 23 | 25 | 30 | 31 | 37 | 39 | 46 | 48 | 60 | 62 | | | | | | | | | | | | | | |
| Length (ft) | Capacity in Cubic Feet of Gas per Hour | | | | | | | | | | | | | | | | | | | | | | | | | | | |
| 10 | 523 | 674 | 1,080 | 1,300 | 2,000 | 2,530 | 4,920 | 5,660 | 8,300 | 9,140 | 18,100 | 19,800 | 34,400 | 40,400 | | | | | | | | | | | | | | |
| 25 | 322 | 420 | 691 | 827 | 1,290 | 1,620 | 3,080 | 3,540 | 5,310 | 5,911 | 11,400 | 12,600 | 22,000 | 25,600 | | | | | | | | | | | | | | |
| 30 | 292 | 382 | 632 | 755 | 1,180 | 1,480 | 2,800 | 3,230 | 4,860 | 5,420 | 10,400 | 11,500 | 20,100 | 23,400 | | | | | | | | | | | | | | |
| 40 | 251 | 329 | 549 | 654 | 1,030 | 1,280 | 2,420 | 2,790 | 4,230 | 4,727 | 8,970 | 10,000 | 17,400 | 20,200 | | | | | | | | | | | | | | |
| 50 | 223 | 293 | 492 | 586 | 926 | 1,150 | 2,160 | 2,490 | 3,790 | 4,251 | 8,020 | 8,930 | 15,600 | 18,100 | | | | | | | | | | | | | | |
| 75 | 180 | 238 | 403 | 479 | 763 | 944 | 1,750 | 2,020 | 3,110 | 3,506 | 6,530 | 7,320 | 12,800 | 14,800 | | | | | | | | | | | | | | |
| 80 | 174 | 230 | 391 | 463 | 740 | 915 | 1,690 | 1,960 | 3,020 | 3,400 | 6,320 | 7,090 | 12,400 | 14,300 | | | | | | | | | | | | | | |
| 100 | 154 | 205 | 350 | 415 | 665 | 820 | 1,510 | 1,740 | 2,710 | 3,057 | 5,650 | 6,350 | 11,100 | 12,800 | | | | | | | | | | | | | | |
| 150 | 124 | 166 | 287 | 339 | 548 | 672 | 1,230 | 1,420 | 2,220 | 2,521 | 4,600 | 5,200 | 9,130 | 10,500 | | | | | | | | | | | | | | |
| 200 | 107 | 143 | 249 | 294 | 478 | 584 | 1,060 | 1,220 | 1,930 | 2,199 | 3,980 | 4,510 | 7,930 | 9,090 | | | | | | | | | | | | | | |
| 250 | 95 | 128 | 223 | 263 | 430 | 524 | 945 | 1,090 | 1,730 | 1,977 | 3,550 | 4,040 | 7,110 | 8,140 | | | | | | | | | | | | | | |
| 300 | 86 | 116 | 204 | 240 | 394 | 479 | 860 | 995 | 1,590 | 1,813 | 3,240 | 3,690 | 6,500 | 7,430 | | | | | | | | | | | | | | |
| 400 | 74 | 100 | 177 | 208 | 343 | 416 | 742 | 858 | 1,380 | 1,581 | 2,800 | 3,210 | 5,650 | 6,440 | | | | | | | | | | | | | | |
| 500 | 66 | 89 | 159 | 186 | 309 | 373 | 662 | 766 | 1,040 | 1,422 | 2,500 | 2,870 | 5,060 | 5,760 | | | | | | | | | | | | | | |

EHD: Equivalent hydraulic diameter. A measure of the relative hydraulic efficiency between different tubing sizes. The greater the value of EHD, the greater the gas capacity of the tubing.

Notes:

- (1) Table does not include effect of pressure drop across line regulator. Where regulator loss exceeds 1 psi, do not use this table. Consult with regulator manufacturer for pressure drops and capacity factors. Pressure drop across regulator may vary with the flow rate.
- (2) CAUTION: Capacities shown in table may exceed maximum capacity of selected regulator. Consult with tubing manufacturer for guidance.
- (3) Table includes losses for four 90 degree bends and two end fittings. Tubing runs with larger numbers of bends and/or fittings shall be increased by an equivalent length of tubing to the following equation: $L = 1.3n$, where L is additional length (ft) of tubing and n is the number of additional fittings and/or bends.
- (4) All table entries are rounded to 3 significant digits.

Table 6.2.1(t) Polyethylene Plastic Pipe

| | | Gas: Natural | | | | | | |
|--------------|----------------------------------------|---------------------------------|--------|--------|--------|--------|--------|--------|
| | | Inlet Pressure: Less than 2 psi | | | | | | |
| | | Pressure Drop: 0.3 in. w.c. | | | | | | |
| | | Specific Gravity: 0.60 | | | | | | |
| | | Pipe Size (in.) | | | | | | |
| Nominal OD: | 1/2 | 3/4 | 1 | 1 1/4 | 1 1/2 | 2 | 3 | 4 |
| Designation: | SDR 9.3 | SDR 11 | SDR 11 | SDR 10 | SDR 11 | SDR 11 | SDR 11 | SDR 11 |
| Actual ID: | 0.660 | 0.860 | 1.077 | 1.328 | 1.554 | 1.943 | 2.864 | 3.682 |
| Length (ft) | Capacity in Cubic Feet of Gas per Hour | | | | | | | |
| 10 | 153 | 305 | 551 | 955 | 1,440 | 2,590 | 7,170 | 13,900 |
| 20 | 105 | 210 | 379 | 656 | 991 | 1,780 | 4,920 | 9,520 |
| 30 | 84 | 169 | 304 | 527 | 796 | 1,430 | 3,950 | 7,640 |
| 40 | 72 | 144 | 260 | 451 | 681 | 1,220 | 3,380 | 6,540 |
| 50 | 64 | 128 | 231 | 400 | 604 | 1,080 | 3,000 | 5,800 |
| 60 | 58 | 116 | 209 | 362 | 547 | 983 | 2,720 | 5,250 |
| 70 | 53 | 107 | 192 | 333 | 503 | 904 | 2,500 | 4,830 |
| 80 | 50 | 99 | 179 | 310 | 468 | 841 | 2,330 | 4,500 |
| 90 | 46 | 93 | 168 | 291 | 439 | 789 | 2,180 | 4,220 |
| 100 | 44 | 88 | 159 | 275 | 415 | 745 | 2,060 | 3,990 |
| 125 | 39 | 78 | 141 | 243 | 368 | 661 | 1,830 | 3,530 |
| 150 | 35 | 71 | 127 | 221 | 333 | 598 | 1,660 | 3,200 |
| 175 | 32 | 65 | 117 | 203 | 306 | 551 | 1,520 | 2,940 |
| 200 | 30 | 60 | 109 | 189 | 285 | 512 | 1,420 | 2,740 |
| 250 | 27 | 54 | 97 | 167 | 253 | 454 | 1,260 | 2,430 |
| 300 | 24 | 48 | 88 | 152 | 229 | 411 | 1,140 | 2,200 |
| 350 | 22 | 45 | 81 | 139 | 211 | 378 | 1,050 | 2,020 |
| 400 | 21 | 42 | 75 | 130 | 196 | 352 | 974 | 1,880 |
| 450 | 19 | 39 | 70 | 122 | 184 | 330 | 914 | 1,770 |
| 500 | 18 | 37 | 66 | 115 | 174 | 312 | 863 | 1,670 |

Note: All table entries are rounded to 3 significant digits.

Table 6.2.1(u) Polyethylene Plastic Pipe

| | | Gas: Natural | | | | | | |
|--------------|----------------------------------------|---------------------------------|--------|--------|--------|--------|--------|--------|
| | | Inlet Pressure: Less than 2 psi | | | | | | |
| | | Pressure Drop: 0.5 in. w.c. | | | | | | |
| | | Specific Gravity: 0.60 | | | | | | |
| | | Pipe Size (in.) | | | | | | |
| Nominal OD: | ½ | ¾ | 1 | 1¼ | 1½ | 2 | 3 | 4 |
| Designation: | SDR 9.3 | SDR 11 | SDR 11 | SDR 10 | SDR 11 | SDR 11 | SDR 11 | SDR 11 |
| Actual ID: | 0.660 | 0.860 | 1.077 | 1.328 | 1.554 | 1.943 | 2.864 | 3.682 |
| Length (ft) | Capacity in Cubic Feet of Gas per Hour | | | | | | | |
| 10 | 201 | 403 | 726 | 1,260 | 1,900 | 3,410 | 9,450 | 18,260 |
| 20 | 138 | 277 | 499 | 865 | 1,310 | 2,350 | 6,490 | 12,550 |
| 30 | 111 | 222 | 401 | 695 | 1,050 | 1,880 | 5,210 | 10,080 |
| 40 | 95 | 190 | 343 | 594 | 898 | 1,610 | 4,460 | 8,630 |
| 50 | 84 | 169 | 304 | 527 | 796 | 1,430 | 3,950 | 7,640 |
| 60 | 76 | 153 | 276 | 477 | 721 | 1,300 | 3,580 | 6,930 |
| 70 | 70 | 140 | 254 | 439 | 663 | 1,190 | 3,300 | 6,370 |
| 80 | 65 | 131 | 236 | 409 | 617 | 1,110 | 3,070 | 5,930 |
| 90 | 61 | 123 | 221 | 383 | 579 | 1,040 | 2,880 | 5,560 |
| 100 | 58 | 116 | 209 | 362 | 547 | 983 | 2,720 | 5,250 |
| 125 | 51 | 103 | 185 | 321 | 485 | 871 | 2,410 | 4,660 |
| 150 | 46 | 93 | 168 | 291 | 439 | 789 | 2,180 | 4,220 |
| 175 | 43 | 86 | 154 | 268 | 404 | 726 | 2,010 | 3,880 |
| 200 | 40 | 80 | 144 | 249 | 376 | 675 | 1,870 | 3,610 |
| 250 | 35 | 71 | 127 | 221 | 333 | 598 | 1,660 | 3,200 |
| 300 | 32 | 64 | 115 | 200 | 302 | 542 | 1,500 | 2,900 |
| 350 | 29 | 59 | 106 | 184 | 278 | 499 | 1,380 | 2,670 |
| 400 | 27 | 55 | 99 | 171 | 258 | 464 | 1,280 | 2,480 |
| 450 | 26 | 51 | 93 | 160 | 242 | 435 | 1,200 | 2,330 |
| 500 | 24 | 48 | 88 | 152 | 229 | 411 | 1,140 | 2,200 |

Note: All table entries are rounded to 3 significant digits.

Table 6.2.1(v) Polyethylene Plastic Pipe

| | | Gas: Natural | | | | | | |
|--------------|----------------------------------------|-------------------------|--------|--------|--------|--------|--------|---------|
| | | Inlet Pressure: 2.0 psi | | | | | | |
| | | Pressure Drop: 1.0 psi | | | | | | |
| | | Specific Gravity: 0.60 | | | | | | |
| | | Pipe Size (in.) | | | | | | |
| Nominal OD: | ½ | ¾ | 1 | 1¼ | 1½ | 2 | 3 | 3 |
| Designation: | SDR 9.3 | SDR 11 | SDR 11 | SDR 10 | SDR 11 | SDR 11 | SDR 11 | SDR 11 |
| Actual ID: | 0.660 | 0.860 | 1.077 | 1.328 | 1.554 | 1.943 | 2.864 | 3.682 |
| Length (ft) | Capacity in Cubic Feet of Gas per Hour | | | | | | | |
| 10 | 1,860 | 3,720 | 6,710 | 11,600 | 17,600 | 31,600 | 87,300 | 169,000 |
| 20 | 1,280 | 2,560 | 4,610 | 7,990 | 12,100 | 21,700 | 60,000 | 116,000 |
| 30 | 1,030 | 2,050 | 3,710 | 6,420 | 9,690 | 17,400 | 48,200 | 93,200 |
| 40 | 878 | 1,760 | 3,170 | 5,490 | 8,300 | 14,900 | 41,200 | 79,700 |
| 50 | 778 | 1,560 | 2,810 | 4,870 | 7,350 | 13,200 | 36,600 | 70,700 |
| 60 | 705 | 1,410 | 2,550 | 4,410 | 6,660 | 12,000 | 33,100 | 64,000 |
| 70 | 649 | 1,300 | 2,340 | 4,060 | 6,130 | 11,000 | 30,500 | 58,900 |
| 80 | 603 | 1,210 | 2,180 | 3,780 | 5,700 | 10,200 | 28,300 | 54,800 |
| 90 | 566 | 1,130 | 2,050 | 3,540 | 5,350 | 9,610 | 26,600 | 51,400 |
| 100 | 535 | 1,070 | 1,930 | 3,350 | 5,050 | 9,080 | 25,100 | 48,600 |
| 125 | 474 | 949 | 1,710 | 2,970 | 4,480 | 8,050 | 22,300 | 43,000 |
| 150 | 429 | 860 | 1,550 | 2,690 | 4,060 | 7,290 | 20,200 | 39,000 |
| 175 | 395 | 791 | 1,430 | 2,470 | 3,730 | 6,710 | 18,600 | 35,900 |
| 200 | 368 | 736 | 1,330 | 2,300 | 3,470 | 6,240 | 17,300 | 33,400 |
| 250 | 326 | 652 | 1,180 | 2,040 | 3,080 | 5,530 | 15,300 | 29,600 |
| 300 | 295 | 591 | 1,070 | 1,850 | 2,790 | 5,010 | 13,900 | 26,800 |
| 350 | 272 | 544 | 981 | 1,700 | 2,570 | 4,610 | 12,800 | 24,700 |
| 400 | 253 | 506 | 913 | 1,580 | 2,390 | 4,290 | 11,900 | 22,900 |
| 450 | 237 | 475 | 856 | 1,480 | 2,240 | 4,020 | 11,100 | 21,500 |
| 500 | 224 | 448 | 809 | 1,400 | 2,120 | 3,800 | 10,500 | 20,300 |
| 550 | 213 | 426 | 768 | 1,330 | 2,010 | 3,610 | 9,990 | 19,300 |
| 600 | 203 | 406 | 733 | 1,270 | 1,920 | 3,440 | 9,530 | 18,400 |
| 650 | 194 | 389 | 702 | 1,220 | 1,840 | 3,300 | 9,130 | 17,600 |
| 700 | 187 | 374 | 674 | 1,170 | 1,760 | 3,170 | 8,770 | 16,900 |
| 750 | 180 | 360 | 649 | 1,130 | 1,700 | 3,050 | 8,450 | 16,300 |
| 800 | 174 | 348 | 627 | 1,090 | 1,640 | 2,950 | 8,160 | 15,800 |
| 850 | 168 | 336 | 607 | 1,050 | 1,590 | 2,850 | 7,890 | 15,300 |
| 900 | 163 | 326 | 588 | 1,020 | 1,540 | 2,770 | 7,650 | 14,800 |
| 950 | 158 | 317 | 572 | 990 | 1,500 | 2,690 | 7,430 | 14,400 |
| 1,000 | 154 | 308 | 556 | 963 | 1,450 | 2,610 | 7,230 | 14,000 |
| 1,100 | 146 | 293 | 528 | 915 | 1,380 | 2,480 | 6,870 | 13,300 |
| 1,200 | 139 | 279 | 504 | 873 | 1,320 | 2,370 | 6,550 | 12,700 |
| 1,300 | 134 | 267 | 482 | 836 | 1,260 | 2,270 | 6,270 | 12,100 |
| 1,400 | 128 | 257 | 463 | 803 | 1,210 | 2,180 | 6,030 | 11,600 |
| 1,500 | 124 | 247 | 446 | 773 | 1,170 | 2,100 | 5,810 | 11,200 |
| 1,600 | 119 | 239 | 431 | 747 | 1,130 | 2,030 | 5,610 | 10,800 |
| 1,700 | 115 | 231 | 417 | 723 | 1,090 | 1,960 | 5,430 | 10,500 |
| 1,800 | 112 | 224 | 404 | 701 | 1,060 | 1,900 | 5,260 | 10,200 |
| 1,900 | 109 | 218 | 393 | 680 | 1,030 | 1,850 | 5,110 | 9,900 |
| 2,000 | 106 | 212 | 382 | 662 | 1,000 | 1,800 | 4,970 | 9,600 |

Note: All table entries are rounded to 3 significant digits.

Table 6.2.1(w) Polyethylene Plastic Tubing

| | Gas: Natural | |
|--------------|----------------------------------------|-------------------|
| | Inlet Pressure: | Less than 2.0 psi |
| | Pressure Drop: | 0.3 in. w.c. |
| | Specific Gravity: | 0.60 |
| | Plastic Tubing Size (CTS) (in.) | |
| Nominal OD: | ½ | 1 |
| Designation: | SDR 7 | SDR 11 |
| Actual ID: | 0.445 | 0.927 |
| Length (ft) | Capacity in Cubic Feet of Gas per Hour | |
| 10 | 54 | 372 |
| 20 | 37 | 256 |
| 30 | 30 | 205 |
| 40 | 26 | 176 |
| 50 | 23 | 156 |
| 60 | 21 | 141 |
| 70 | 19 | 130 |
| 80 | 18 | 121 |
| 90 | 17 | 113 |
| 100 | 16 | 107 |
| 125 | 14 | 95 |
| 150 | 13 | 86 |
| 175 | 12 | 79 |
| 200 | 11 | 74 |
| 225 | 10 | 69 |
| 250 | NA | 65 |
| 275 | NA | 62 |
| 300 | NA | 59 |
| 350 | NA | 54 |
| 400 | NA | 51 |
| 450 | NA | 47 |
| 500 | NA | 45 |

CTS: Copper tube size.

NA: A flow of less than 10 cfh.

Note: All table entries are rounded to 3 significant digits.

Table 6.2.1(x) Polyethylene Plastic Tubing

| | Gas: Natural | |
|--------------|----------------------------------------|-------------------|
| | Inlet Pressure: | Less than 2.0 psi |
| | Pressure Drop: | 0.5 in. w.c. |
| | Specific Gravity: | 0.60 |
| | Plastic Tubing Size (CTS) (in.) | |
| Nominal OD: | ½ | 1 |
| Designation: | SDR 7 | SDR 11 |
| Actual ID: | 0.445 | 0.927 |
| Length (ft) | Capacity in Cubic Feet of Gas per Hour | |
| 10 | 72 | 490 |
| 20 | 49 | 337 |
| 30 | 39 | 271 |
| 40 | 34 | 232 |
| 50 | 30 | 205 |
| 60 | 27 | 186 |
| 70 | 25 | 171 |
| 80 | 23 | 159 |
| 90 | 22 | 149 |
| 100 | 21 | 141 |
| 125 | 18 | 125 |
| 150 | 17 | 113 |
| 175 | 15 | 104 |
| 200 | 14 | 97 |
| 225 | 13 | 91 |
| 250 | 12 | 86 |
| 275 | 11 | 82 |
| 300 | 11 | 78 |
| 350 | 10 | 72 |
| 400 | NA | 67 |
| 450 | NA | 63 |
| 500 | NA | 59 |

CTS: Copper tube size.

NA: A flow of less than 10 cfh.

Note: All table entries are rounded to 3 significant digits.

Table 6.3.1(a) Schedule 40 Metallic Pipe

| | | | | | | | Gas: | Undiluted Propane | | |
|--------------------------------------------------------------------------------------------------------------------|---------------------------------------|-------|--------|--------|--------|--------|-------------------|-------------------|---------|--|
| | | | | | | | Inlet Pressure: | 10.0 psi | | |
| | | | | | | | Pressure Drop: | 1.0 psi | | |
| | | | | | | | Specific Gravity: | 1.50 | | |
| INTENDED USE: Pipe Sizing Between First-Stage (High-Pressure) Regulator and Second-Stage (Low-Pressure) Regulator. | | | | | | | | | | |
| Pipe Size (in.) | | | | | | | | | | |
| Nominal Inside: | ½ | ¾ | 1 | 1¼ | 1½ | 2 | 2 ½ | 3 | 4 | |
| Actual: | 0.622 | 0.824 | 1.049 | 1.380 | 1.610 | 2.067 | 2.469 | 3.068 | 4.026 | |
| Length (ft) | Capacity in Thousands of Btu per Hour | | | | | | | | | |
| 10 | 3,320 | 6,950 | 13,100 | 26,900 | 40,300 | 77,600 | 124,000 | 219,000 | 446,000 | |
| 20 | 2,280 | 4,780 | 9,000 | 18,500 | 27,700 | 53,300 | 85,000 | 150,000 | 306,000 | |
| 30 | 1,830 | 3,840 | 7,220 | 14,800 | 22,200 | 42,800 | 68,200 | 121,000 | 246,000 | |
| 40 | 1,570 | 3,280 | 6,180 | 12,700 | 19,000 | 36,600 | 58,400 | 103,000 | 211,000 | |
| 50 | 1,390 | 2,910 | 5,480 | 11,300 | 16,900 | 32,500 | 51,700 | 91,500 | 187,000 | |
| 60 | 1,260 | 2,640 | 4,970 | 10,200 | 15,300 | 29,400 | 46,900 | 82,900 | 169,000 | |
| 70 | 1,160 | 2,430 | 4,570 | 9,380 | 14,100 | 27,100 | 43,100 | 76,300 | 156,000 | |
| 80 | 1,080 | 2,260 | 4,250 | 8,730 | 13,100 | 25,200 | 40,100 | 70,900 | 145,000 | |
| 90 | 1,010 | 2,120 | 3,990 | 8,190 | 12,300 | 23,600 | 37,700 | 66,600 | 136,000 | |
| 100 | 956 | 2,000 | 3,770 | 7,730 | 11,600 | 22,300 | 35,600 | 62,900 | 128,000 | |
| 125 | 848 | 1,770 | 3,340 | 6,850 | 10,300 | 19,800 | 31,500 | 55,700 | 114,000 | |
| 150 | 768 | 1,610 | 3,020 | 6,210 | 9,300 | 17,900 | 28,600 | 50,500 | 103,000 | |
| 175 | 706 | 1,480 | 2,780 | 5,710 | 8,560 | 16,500 | 26,300 | 46,500 | 94,700 | |
| 200 | 657 | 1,370 | 2,590 | 5,320 | 7,960 | 15,300 | 24,400 | 43,200 | 88,100 | |
| 250 | 582 | 1,220 | 2,290 | 4,710 | 7,060 | 13,600 | 21,700 | 38,300 | 78,100 | |
| 300 | 528 | 1,100 | 2,080 | 4,270 | 6,400 | 12,300 | 19,600 | 34,700 | 70,800 | |
| 350 | 486 | 1,020 | 1,910 | 3,930 | 5,880 | 11,300 | 18,100 | 31,900 | 65,100 | |
| 400 | 452 | 945 | 1,780 | 3,650 | 5,470 | 10,500 | 16,800 | 29,700 | 60,600 | |
| 450 | 424 | 886 | 1,670 | 3,430 | 5,140 | 9,890 | 15,800 | 27,900 | 56,800 | |
| 500 | 400 | 837 | 1,580 | 3,240 | 4,850 | 9,340 | 14,900 | 26,300 | 53,700 | |
| 550 | 380 | 795 | 1,500 | 3,070 | 4,610 | 8,870 | 14,100 | 25,000 | 51,000 | |
| 600 | 363 | 759 | 1,430 | 2,930 | 4,400 | 8,460 | 13,500 | 23,900 | 48,600 | |
| 650 | 347 | 726 | 1,370 | 2,810 | 4,210 | 8,110 | 12,900 | 22,800 | 46,600 | |
| 700 | 334 | 698 | 1,310 | 2,700 | 4,040 | 7,790 | 12,400 | 21,900 | 44,800 | |
| 750 | 321 | 672 | 1,270 | 2,600 | 3,900 | 7,500 | 12,000 | 21,100 | 43,100 | |
| 800 | 310 | 649 | 1,220 | 2,510 | 3,760 | 7,240 | 11,500 | 20,400 | 41,600 | |
| 850 | 300 | 628 | 1,180 | 2,430 | 3,640 | 7,010 | 11,200 | 19,800 | 40,300 | |
| 900 | 291 | 609 | 1,150 | 2,360 | 3,530 | 6,800 | 10,800 | 19,200 | 39,100 | |
| 950 | 283 | 592 | 1,110 | 2,290 | 3,430 | 6,600 | 10,500 | 18,600 | 37,900 | |
| 1,000 | 275 | 575 | 1,080 | 2,230 | 3,330 | 6,420 | 10,200 | 18,100 | 36,900 | |
| 1,100 | 261 | 546 | 1,030 | 2,110 | 3,170 | 6,100 | 9,720 | 17,200 | 35,000 | |
| 1,200 | 249 | 521 | 982 | 2,020 | 3,020 | 5,820 | 9,270 | 16,400 | 33,400 | |
| 1,300 | 239 | 499 | 940 | 1,930 | 2,890 | 5,570 | 8,880 | 15,700 | 32,000 | |
| 1,400 | 229 | 480 | 903 | 1,850 | 2,780 | 5,350 | 8,530 | 15,100 | 30,800 | |
| 1,500 | 221 | 462 | 870 | 1,790 | 2,680 | 5,160 | 8,220 | 14,500 | 29,600 | |
| 1,600 | 213 | 446 | 840 | 1,730 | 2,590 | 4,980 | 7,940 | 14,000 | 28,600 | |
| 1,700 | 206 | 432 | 813 | 1,670 | 2,500 | 4,820 | 7,680 | 13,600 | 27,700 | |
| 1,800 | 200 | 419 | 789 | 1,620 | 2,430 | 4,670 | 7,450 | 13,200 | 26,900 | |
| 1,900 | 194 | 407 | 766 | 1,570 | 2,360 | 4,540 | 7,230 | 12,800 | 26,100 | |
| 2,000 | 189 | 395 | 745 | 1,530 | 2,290 | 4,410 | 7,030 | 12,400 | 25,400 | |

Note: All table entries are rounded to 3 significant digits.

Table 6.3.1(b) Schedule 40 Metallic Pipe

| | | | | | | | | | | Gas: Undiluted Propane |
|---------------------------------------------------------------------------------------------------------------------------|---------------------------------------|--------|--------|--------|--------|---------|---------|---------|---------|--------------------------|
| | | | | | | | | | | Inlet Pressure: 10.0 psi |
| | | | | | | | | | | Pressure Drop: 3.0 psi |
| | | | | | | | | | | Specific Gravity: 1.50 |
| INTENDED USE: Pipe Sizing Between First-Stage (High-Pressure) Regulator and Second-Stage (Low-Pressure) Regulator. | | | | | | | | | | |
| Pipe Size (in.) | | | | | | | | | | |
| Nominal Inside: | ½ | ¾ | 1 | 1¼ | 1½ | 2 | 2½ | 3 | 4 | |
| Actual: | 0.622 | 0.824 | 1.049 | 1.380 | 1.610 | 2.067 | 2.469 | 3.068 | 4.026 | |
| Length (ft) | Capacity in Thousands of Btu per Hour | | | | | | | | | |
| 10 | 5,890 | 12,300 | 23,200 | 47,600 | 71,300 | 137,000 | 219,000 | 387,000 | 789,000 | |
| 20 | 4,050 | 8,460 | 15,900 | 32,700 | 49,000 | 94,400 | 150,000 | 266,000 | 543,000 | |
| 30 | 3,250 | 6,790 | 12,800 | 26,300 | 39,400 | 75,800 | 121,000 | 214,000 | 436,000 | |
| 40 | 2,780 | 5,810 | 11,000 | 22,500 | 33,700 | 64,900 | 103,000 | 183,000 | 373,000 | |
| 50 | 2,460 | 5,150 | 9,710 | 19,900 | 29,900 | 57,500 | 91,600 | 162,000 | 330,000 | |
| 60 | 2,230 | 4,670 | 8,790 | 18,100 | 27,100 | 52,100 | 83,000 | 147,000 | 299,000 | |
| 70 | 2,050 | 4,300 | 8,090 | 16,600 | 24,900 | 47,900 | 76,400 | 135,000 | 275,000 | |
| 80 | 1,910 | 4,000 | 7,530 | 15,500 | 23,200 | 44,600 | 71,100 | 126,000 | 256,000 | |
| 90 | 1,790 | 3,750 | 7,060 | 14,500 | 21,700 | 41,800 | 66,700 | 118,000 | 240,000 | |
| 100 | 1,690 | 3,540 | 6,670 | 13,700 | 20,500 | 39,500 | 63,000 | 111,000 | 227,000 | |
| 125 | 1,500 | 3,140 | 5,910 | 12,100 | 18,200 | 35,000 | 55,800 | 98,700 | 201,000 | |
| 150 | 1,360 | 2,840 | 5,360 | 11,000 | 16,500 | 31,700 | 50,600 | 89,400 | 182,000 | |
| 175 | 1,250 | 2,620 | 4,930 | 10,100 | 15,200 | 29,200 | 46,500 | 82,300 | 167,800 | |
| 200 | 1,160 | 2,430 | 4,580 | 9,410 | 14,100 | 27,200 | 43,300 | 76,500 | 156,100 | |
| 250 | 1,030 | 2,160 | 4,060 | 8,340 | 12,500 | 24,100 | 38,400 | 67,800 | 138,400 | |
| 300 | 935 | 1,950 | 3,680 | 7,560 | 11,300 | 21,800 | 34,800 | 61,500 | 125,400 | |
| 350 | 860 | 1,800 | 3,390 | 6,950 | 10,400 | 20,100 | 32,000 | 56,500 | 115,300 | |
| 400 | 800 | 1,670 | 3,150 | 6,470 | 9,690 | 18,700 | 29,800 | 52,600 | 107,300 | |
| 450 | 751 | 1,570 | 2,960 | 6,070 | 9,090 | 17,500 | 27,900 | 49,400 | 100,700 | |
| 500 | 709 | 1,480 | 2,790 | 5,730 | 8,590 | 16,500 | 26,400 | 46,600 | 95,100 | |
| 550 | 673 | 1,410 | 2,650 | 5,450 | 8,160 | 15,700 | 25,000 | 44,300 | 90,300 | |
| 600 | 642 | 1,340 | 2,530 | 5,200 | 7,780 | 15,000 | 23,900 | 42,200 | 86,200 | |
| 650 | 615 | 1,290 | 2,420 | 4,980 | 7,450 | 14,400 | 22,900 | 40,500 | 82,500 | |
| 700 | 591 | 1,240 | 2,330 | 4,780 | 7,160 | 13,800 | 22,000 | 38,900 | 79,300 | |
| 750 | 569 | 1,190 | 2,240 | 4,600 | 6,900 | 13,300 | 21,200 | 37,400 | 76,400 | |
| 800 | 550 | 1,150 | 2,170 | 4,450 | 6,660 | 12,800 | 20,500 | 36,200 | 73,700 | |
| 850 | 532 | 1,110 | 2,100 | 4,300 | 6,450 | 12,400 | 19,800 | 35,000 | 71,400 | |
| 900 | 516 | 1,080 | 2,030 | 4,170 | 6,250 | 12,000 | 19,200 | 33,900 | 69,200 | |
| 950 | 501 | 1,050 | 1,970 | 4,050 | 6,070 | 11,700 | 18,600 | 32,900 | 67,200 | |
| 1,000 | 487 | 1,020 | 1,920 | 3,940 | 5,900 | 11,400 | 18,100 | 32,000 | 65,400 | |
| 1,100 | 463 | 968 | 1,820 | 3,740 | 5,610 | 10,800 | 17,200 | 30,400 | 62,100 | |
| 1,200 | 442 | 923 | 1,740 | 3,570 | 5,350 | 10,300 | 16,400 | 29,000 | 59,200 | |
| 1,300 | 423 | 884 | 1,670 | 3,420 | 5,120 | 9,870 | 15,700 | 27,800 | 56,700 | |
| 1,400 | 406 | 849 | 1,600 | 3,280 | 4,920 | 9,480 | 15,100 | 26,700 | 54,500 | |
| 1,500 | 391 | 818 | 1,540 | 3,160 | 4,740 | 9,130 | 14,600 | 25,700 | 52,500 | |
| 1,600 | 378 | 790 | 1,490 | 3,060 | 4,580 | 8,820 | 14,100 | 24,800 | 50,700 | |
| 1,700 | 366 | 765 | 1,440 | 2,960 | 4,430 | 8,530 | 13,600 | 24,000 | 49,000 | |
| 1,800 | 355 | 741 | 1,400 | 2,870 | 4,300 | 8,270 | 13,200 | 23,300 | 47,600 | |
| 1,900 | 344 | 720 | 1,360 | 2,780 | 4,170 | 8,040 | 12,800 | 22,600 | 46,200 | |
| 2,000 | 335 | 700 | 1,320 | 2,710 | 4,060 | 7,820 | 12,500 | 22,000 | 44,900 | |

Note: All table entries are rounded to 3 significant digits.

Table 6.3.1(c) Schedule 40 Metallic Pipe

| | | | | | | | | | | Gas: | Undiluted Propane |
|-------------------------------------------------------------------------------|---------------------------------------|-------|--------|--------|--------|--------|--------|---------|---------|-------------------|-------------------|
| | | | | | | | | | | Inlet Pressure: | 2.0 psi |
| | | | | | | | | | | Pressure Drop: | 1.0 psi |
| | | | | | | | | | | Specific Gravity: | 1.50 |
| INTENDED USE: Pipe Sizing Between 2 psig Service and Line Pressure Regulator. | | | | | | | | | | | |
| | | | | | | | | | | Pipe Size (in.) | |
| Nominal: | ½ | ¾ | 1 | 1¼ | 1½ | 2 | 2½ | 3 | 4 | | |
| Actual ID: | 0.622 | 0.824 | 1.049 | 1.380 | 1.610 | 2.067 | 2.469 | 3.068 | 4.026 | | |
| Length (ft) | Capacity in Thousands of Btu per Hour | | | | | | | | | | |
| 10 | 2,680 | 5,590 | 10,500 | 21,600 | 32,400 | 62,400 | 99,500 | 176,000 | 359,000 | | |
| 20 | 1,840 | 3,850 | 7,240 | 14,900 | 22,300 | 42,900 | 68,400 | 121,000 | 247,000 | | |
| 30 | 1,480 | 3,090 | 5,820 | 11,900 | 17,900 | 34,500 | 54,900 | 97,100 | 198,000 | | |
| 40 | 1,260 | 2,640 | 4,980 | 10,200 | 15,300 | 29,500 | 47,000 | 83,100 | 170,000 | | |
| 50 | 1,120 | 2,340 | 4,410 | 9,060 | 13,600 | 26,100 | 41,700 | 73,700 | 150,000 | | |
| 60 | 1,010 | 2,120 | 4,000 | 8,210 | 12,300 | 23,700 | 37,700 | 66,700 | 136,000 | | |
| 70 | 934 | 1,950 | 3,680 | 7,550 | 11,300 | 21,800 | 34,700 | 61,400 | 125,000 | | |
| 80 | 869 | 1,820 | 3,420 | 7,020 | 10,500 | 20,300 | 32,300 | 57,100 | 116,000 | | |
| 90 | 815 | 1,700 | 3,210 | 6,590 | 9,880 | 19,000 | 30,300 | 53,600 | 109,000 | | |
| 100 | 770 | 1,610 | 3,030 | 6,230 | 9,330 | 18,000 | 28,600 | 50,600 | 103,000 | | |
| 125 | 682 | 1,430 | 2,690 | 5,520 | 8,270 | 15,900 | 25,400 | 44,900 | 91,500 | | |
| 150 | 618 | 1,290 | 2,440 | 5,000 | 7,490 | 14,400 | 23,000 | 40,700 | 82,900 | | |
| 175 | 569 | 1,190 | 2,240 | 4,600 | 6,890 | 13,300 | 21,200 | 37,400 | 76,300 | | |
| 200 | 529 | 1,110 | 2,080 | 4,280 | 6,410 | 12,300 | 19,700 | 34,800 | 71,000 | | |
| 250 | 469 | 981 | 1,850 | 3,790 | 5,680 | 10,900 | 17,400 | 30,800 | 62,900 | | |
| 300 | 425 | 889 | 1,670 | 3,440 | 5,150 | 9,920 | 15,800 | 27,900 | 57,000 | | |
| 350 | 391 | 817 | 1,540 | 3,160 | 4,740 | 9,120 | 14,500 | 25,700 | 52,400 | | |
| 400 | 364 | 760 | 1,430 | 2,940 | 4,410 | 8,490 | 13,500 | 23,900 | 48,800 | | |
| 450 | 341 | 714 | 1,340 | 2,760 | 4,130 | 7,960 | 12,700 | 22,400 | 45,800 | | |
| 500 | 322 | 674 | 1,270 | 2,610 | 3,910 | 7,520 | 12,000 | 21,200 | 43,200 | | |
| 550 | 306 | 640 | 1,210 | 2,480 | 3,710 | 7,140 | 11,400 | 20,100 | 41,100 | | |
| 600 | 292 | 611 | 1,150 | 2,360 | 3,540 | 6,820 | 10,900 | 19,200 | 39,200 | | |
| 650 | 280 | 585 | 1,100 | 2,260 | 3,390 | 6,530 | 10,400 | 18,400 | 37,500 | | |
| 700 | 269 | 562 | 1,060 | 2,170 | 3,260 | 6,270 | 9,990 | 17,700 | 36,000 | | |
| 750 | 259 | 541 | 1,020 | 2,090 | 3,140 | 6,040 | 9,630 | 17,000 | 34,700 | | |
| 800 | 250 | 523 | 985 | 2,020 | 3,030 | 5,830 | 9,300 | 16,400 | 33,500 | | |
| 850 | 242 | 506 | 953 | 1,960 | 2,930 | 5,640 | 9,000 | 15,900 | 32,400 | | |
| 900 | 235 | 490 | 924 | 1,900 | 2,840 | 5,470 | 8,720 | 15,400 | 31,500 | | |
| 950 | 228 | 476 | 897 | 1,840 | 2,760 | 5,310 | 8,470 | 15,000 | 30,500 | | |
| 1,000 | 222 | 463 | 873 | 1,790 | 2,680 | 5,170 | 8,240 | 14,600 | 29,700 | | |
| 1,100 | 210 | 440 | 829 | 1,700 | 2,550 | 4,910 | 7,830 | 13,800 | 28,200 | | |
| 1,200 | 201 | 420 | 791 | 1,620 | 2,430 | 4,680 | 7,470 | 13,200 | 26,900 | | |
| 1,300 | 192 | 402 | 757 | 1,550 | 2,330 | 4,490 | 7,150 | 12,600 | 25,800 | | |
| 1,400 | 185 | 386 | 727 | 1,490 | 2,240 | 4,310 | 6,870 | 12,100 | 24,800 | | |
| 1,500 | 178 | 372 | 701 | 1,440 | 2,160 | 4,150 | 6,620 | 11,700 | 23,900 | | |
| 1,600 | 172 | 359 | 677 | 1,390 | 2,080 | 4,010 | 6,390 | 11,300 | 23,000 | | |
| 1,700 | 166 | 348 | 655 | 1,340 | 2,010 | 3,880 | 6,180 | 10,900 | 22,300 | | |
| 1,800 | 161 | 337 | 635 | 1,300 | 1,950 | 3,760 | 6,000 | 10,600 | 21,600 | | |
| 1,900 | 157 | 327 | 617 | 1,270 | 1,900 | 3,650 | 5,820 | 10,300 | 21,000 | | |
| 2,000 | 152 | 318 | 600 | 1,230 | 1,840 | 3,550 | 5,660 | 10,000 | 20,400 | | |

Note: All table entries are rounded to 3 significant digits.

Table 6.3.1(d) Schedule 40 Metallic Pipe

| | | | | | | | | | | Gas: Undiluted Propane | |
|---------------------------------------------------------------------------------------------------|---------------------------------------|-------|-------|-------|-------|-------|--------|--------|--------|-------------------------------|--|
| | | | | | | | | | | Inlet Pressure: 11.0 in. w.c. | |
| | | | | | | | | | | Pressure Drop: 0.5 in. w.c. | |
| | | | | | | | | | | Specific Gravity: 1.50 | |
| INTENDED USE: Pipe Sizing Between Single- or Second-Stage (Low-Pressure) Regulator and Appliance. | | | | | | | | | | | |
| Pipe Size (in.) | | | | | | | | | | | |
| Nominal Inside: | ½ | ¾ | 1 | 1¼ | 1½ | 2 | 2 ½ | 3 | 4 | | |
| Actual: | 0.622 | 0.824 | 1.049 | 1.380 | 1.610 | 2.067 | 2.469 | 3.068 | 4.026 | | |
| Length (ft) | Capacity in Thousands of Btu per Hour | | | | | | | | | | |
| 10 | 291 | 608 | 1,150 | 2,350 | 3,520 | 6,790 | 10,800 | 19,100 | 39,000 | | |
| 20 | 200 | 418 | 787 | 1,620 | 2,420 | 4,660 | 7,430 | 13,100 | 26,800 | | |
| 30 | 160 | 336 | 632 | 1,300 | 1,940 | 3,750 | 5,970 | 10,600 | 21,500 | | |
| 40 | 137 | 287 | 541 | 1,110 | 1,660 | 3,210 | 5,110 | 9,030 | 18,400 | | |
| 50 | 122 | 255 | 480 | 985 | 1,480 | 2,840 | 4,530 | 8,000 | 16,300 | | |
| 60 | 110 | 231 | 434 | 892 | 1,340 | 2,570 | 4,100 | 7,250 | 14,800 | | |
| 80 | 101 | 212 | 400 | 821 | 1,230 | 2,370 | 3,770 | 6,670 | 13,600 | | |
| 100 | 94 | 197 | 372 | 763 | 1,140 | 2,200 | 3,510 | 6,210 | 12,700 | | |
| 125 | 89 | 185 | 349 | 716 | 1,070 | 2,070 | 3,290 | 5,820 | 11,900 | | |
| 150 | 84 | 175 | 330 | 677 | 1,010 | 1,950 | 3,110 | 5,500 | 11,200 | | |
| 175 | 74 | 155 | 292 | 600 | 899 | 1,730 | 2,760 | 4,880 | 9,950 | | |
| 200 | 67 | 140 | 265 | 543 | 814 | 1,570 | 2,500 | 4,420 | 9,010 | | |
| 250 | 62 | 129 | 243 | 500 | 749 | 1,440 | 2,300 | 4,060 | 8,290 | | |
| 300 | 58 | 120 | 227 | 465 | 697 | 1,340 | 2,140 | 3,780 | 7,710 | | |
| 350 | 51 | 107 | 201 | 412 | 618 | 1,190 | 1,900 | 3,350 | 6,840 | | |
| 400 | 46 | 97 | 182 | 373 | 560 | 1,080 | 1,720 | 3,040 | 6,190 | | |
| 450 | 42 | 89 | 167 | 344 | 515 | 991 | 1,580 | 2,790 | 5,700 | | |
| 500 | 40 | 83 | 156 | 320 | 479 | 922 | 1,470 | 2,600 | 5,300 | | |
| 550 | 37 | 78 | 146 | 300 | 449 | 865 | 1,380 | 2,440 | 4,970 | | |
| 600 | 35 | 73 | 138 | 283 | 424 | 817 | 1,300 | 2,300 | 4,700 | | |
| 650 | 33 | 70 | 131 | 269 | 403 | 776 | 1,240 | 2,190 | 4,460 | | |
| 700 | 32 | 66 | 125 | 257 | 385 | 741 | 1,180 | 2,090 | 4,260 | | |
| 750 | 30 | 64 | 120 | 246 | 368 | 709 | 1,130 | 2,000 | 4,080 | | |
| 800 | 29 | 61 | 115 | 236 | 354 | 681 | 1,090 | 1,920 | 3,920 | | |
| 850 | 28 | 59 | 111 | 227 | 341 | 656 | 1,050 | 1,850 | 3,770 | | |
| 900 | 27 | 57 | 107 | 220 | 329 | 634 | 1,010 | 1,790 | 3,640 | | |
| 950 | 26 | 55 | 104 | 213 | 319 | 613 | 978 | 1,730 | 3,530 | | |
| 1,000 | 25 | 53 | 100 | 206 | 309 | 595 | 948 | 1,680 | 3,420 | | |
| 1,100 | 25 | 52 | 97 | 200 | 300 | 578 | 921 | 1,630 | 3,320 | | |
| 1,200 | 24 | 50 | 95 | 195 | 292 | 562 | 895 | 1,580 | 3,230 | | |
| 1,300 | 23 | 48 | 90 | 185 | 277 | 534 | 850 | 1,500 | 3,070 | | |
| 1,400 | 22 | 46 | 86 | 176 | 264 | 509 | 811 | 1,430 | 2,930 | | |
| 1,500 | 21 | 44 | 82 | 169 | 253 | 487 | 777 | 1,370 | 2,800 | | |
| 1,600 | 20 | 42 | 79 | 162 | 243 | 468 | 746 | 1,320 | 2,690 | | |
| 1,700 | 19 | 40 | 76 | 156 | 234 | 451 | 719 | 1,270 | 2,590 | | |
| 1,800 | 19 | 39 | 74 | 151 | 226 | 436 | 694 | 1,230 | 2,500 | | |
| 1,900 | 18 | 38 | 71 | 146 | 219 | 422 | 672 | 1,190 | 2,420 | | |
| 2,000 | 18 | 37 | 69 | 142 | 212 | 409 | 652 | 1,150 | 2,350 | | |

Note: All table entries are rounded to 3 significant digits.

Table 6.3.1(e) Semirigid Copper Tubing

| | | Gas: Undiluted Propane | | | | | | | | |
|--------------------------------------------------------------------------------------------------------------------|--------|---------------------------------------|-------|-------|-------|--------|--------|--------|--------|-------|
| | | Inlet Pressure: 10.0 psi | | | | | | | | |
| | | Pressure Drop: 1.0 psi | | | | | | | | |
| | | Specific Gravity: 1.50 | | | | | | | | |
| INTENDED USE: Tube Sizing Between First-Stage (High-Pressure) Regulator and Second-Stage (Low-Pressure) Regulator. | | | | | | | | | | |
| Tube Size (in.) | | | | | | | | | | |
| Nominal: | K & L: | ¼ | ⅜ | ½ | ⅝ | ¾ | 1 | 1¼ | 1½ | 2 |
| | ACR: | ⅜ | ½ | ⅝ | ¾ | ⅞ | 1⅛ | 1⅜ | — | — |
| Outside: | | 0.375 | 0.500 | 0.625 | 0.750 | 0.875 | 1.125 | 1.375 | 1.625 | 2.125 |
| Inside:* | | 0.305 | 0.402 | 0.527 | 0.652 | 0.745 | 0.995 | 1.245 | 1.481 | 1.959 |
| Length (ft) | | Capacity in Thousands of Btu per Hour | | | | | | | | |
| 10 | 513 | 1,060 | 2,150 | 3,760 | 5,330 | 11,400 | 20,500 | 32,300 | 67,400 | |
| 20 | 352 | 727 | 1,480 | 2,580 | 3,670 | 7,830 | 14,100 | 22,200 | 46,300 | |
| 30 | 283 | 584 | 1,190 | 2,080 | 2,940 | 6,290 | 11,300 | 17,900 | 37,200 | |
| 40 | 242 | 500 | 1,020 | 1,780 | 2,520 | 5,380 | 9,690 | 15,300 | 31,800 | |
| 50 | 215 | 443 | 901 | 1,570 | 2,230 | 4,770 | 8,590 | 13,500 | 28,200 | |
| 60 | 194 | 401 | 816 | 1,430 | 2,020 | 4,320 | 7,780 | 12,300 | 25,600 | |
| 70 | 179 | 369 | 751 | 1,310 | 1,860 | 3,980 | 7,160 | 11,300 | 23,500 | |
| 80 | 166 | 343 | 699 | 1,220 | 1,730 | 3,700 | 6,660 | 10,500 | 21,900 | |
| 90 | 156 | 322 | 655 | 1,150 | 1,630 | 3,470 | 6,250 | 9,850 | 20,500 | |
| 100 | 147 | 304 | 619 | 1,080 | 1,540 | 3,280 | 5,900 | 9,310 | 19,400 | |
| 125 | 131 | 270 | 549 | 959 | 1,360 | 2,910 | 5,230 | 8,250 | 17,200 | |
| 150 | 118 | 244 | 497 | 869 | 1,230 | 2,630 | 4,740 | 7,470 | 15,600 | |
| 175 | 109 | 225 | 457 | 799 | 1,130 | 2,420 | 4,360 | 6,880 | 14,300 | |
| 200 | 101 | 209 | 426 | 744 | 1,060 | 2,250 | 4,060 | 6,400 | 13,300 | |
| 250 | 90 | 185 | 377 | 659 | 935 | 2,000 | 3,600 | 5,670 | 11,800 | |
| 300 | 81 | 168 | 342 | 597 | 847 | 1,810 | 3,260 | 5,140 | 10,700 | |
| 350 | 75 | 155 | 314 | 549 | 779 | 1,660 | 3,000 | 4,730 | 9,840 | |
| 400 | 70 | 144 | 292 | 511 | 725 | 1,550 | 2,790 | 4,400 | 9,160 | |
| 450 | 65 | 135 | 274 | 480 | 680 | 1,450 | 2,620 | 4,130 | 8,590 | |
| 500 | 62 | 127 | 259 | 453 | 643 | 1,370 | 2,470 | 3,900 | 8,120 | |
| 550 | 59 | 121 | 246 | 430 | 610 | 1,300 | 2,350 | 3,700 | 7,710 | |
| 600 | 56 | 115 | 235 | 410 | 582 | 1,240 | 2,240 | 3,530 | 7,350 | |
| 650 | 54 | 111 | 225 | 393 | 558 | 1,190 | 2,140 | 3,380 | 7,040 | |
| 700 | 51 | 106 | 216 | 378 | 536 | 1,140 | 2,060 | 3,250 | 6,770 | |
| 750 | 50 | 102 | 208 | 364 | 516 | 1,100 | 1,980 | 3,130 | 6,520 | |
| 800 | 48 | 99 | 201 | 351 | 498 | 1,060 | 1,920 | 3,020 | 6,290 | |
| 850 | 46 | 96 | 195 | 340 | 482 | 1,030 | 1,850 | 2,920 | 6,090 | |
| 900 | 45 | 93 | 189 | 330 | 468 | 1,000 | 1,800 | 2,840 | 5,910 | |
| 950 | 44 | 90 | 183 | 320 | 454 | 970 | 1,750 | 2,750 | 5,730 | |
| 1,000 | 42 | 88 | 178 | 311 | 442 | 944 | 1,700 | 2,680 | 5,580 | |
| 1,100 | 40 | 83 | 169 | 296 | 420 | 896 | 1,610 | 2,540 | 5,300 | |
| 1,200 | 38 | 79 | 161 | 282 | 400 | 855 | 1,540 | 2,430 | 5,050 | |
| 1,300 | 37 | 76 | 155 | 270 | 383 | 819 | 1,470 | 2,320 | 4,840 | |
| 1,400 | 35 | 73 | 148 | 260 | 368 | 787 | 1,420 | 2,230 | 4,650 | |
| 1,500 | 34 | 70 | 143 | 250 | 355 | 758 | 1,360 | 2,150 | 4,480 | |
| 1,600 | 33 | 68 | 138 | 241 | 343 | 732 | 1,320 | 2,080 | 4,330 | |
| 1,700 | 32 | 66 | 134 | 234 | 331 | 708 | 1,270 | 2,010 | 4,190 | |
| 1,800 | 31 | 64 | 130 | 227 | 321 | 687 | 1,240 | 1,950 | 4,060 | |
| 1,900 | 30 | 62 | 126 | 220 | 312 | 667 | 1,200 | 1,890 | 3,940 | |
| 2,000 | 29 | 60 | 122 | 214 | 304 | 648 | 1,170 | 1,840 | 3,830 | |

Note: All table entries are rounded to 3 significant digits.

*Table capacities are based on Type K copper tubing inside diameter (shown), which has the smallest inside diameter of the copper tubing products.

Table 6.3.1(f) Semirigid Copper Tubing

| | | | | | | | Gas: | Undiluted Propane | | | |
|---------------------------------------------------------------------------------------------------|--------|---------------------------------------|-------|-------|-------|-------|-------------------|-------------------|-------|-------|--|
| | | | | | | | Inlet Pressure: | 11.0 in. w.c. | | | |
| | | | | | | | Pressure Drop: | 0.5 in. w.c. | | | |
| | | | | | | | Specific Gravity: | 1.50 | | | |
| INTENDED USE: Tube Sizing Between Single- or Second-Stage (Low-Pressure) Regulator and Appliance. | | | | | | | | | | | |
| Tube Size (in.) | | | | | | | | | | | |
| Nominal: | K & L: | ¼ | ⅜ | ½ | ⅝ | ¾ | 1 | 1¼ | 1½ | 2 | |
| | ACR: | ⅜ | ½ | ⅝ | ¾ | 7⁄8 | 1⅛ | 1⅜ | — | — | |
| Outside: | | 0.375 | 0.500 | 0.625 | 0.750 | 0.875 | 1.125 | 1.375 | 1.625 | 2.125 | |
| Inside*: | | 0.305 | 0.402 | 0.527 | 0.652 | 0.745 | 0.995 | 1.245 | 1.481 | 1.959 | |
| Length (ft) | | Capacity in Thousands of Btu per Hour | | | | | | | | | |
| 10 | 45 | 93 | 188 | 329 | 467 | 997 | 1,800 | 2,830 | 5,890 | | |
| 20 | 31 | 64 | 129 | 226 | 321 | 685 | 1,230 | 1,950 | 4,050 | | |
| 30 | 25 | 51 | 104 | 182 | 258 | 550 | 991 | 1,560 | 3,250 | | |
| 40 | 21 | 44 | 89 | 155 | 220 | 471 | 848 | 1,340 | 2,780 | | |
| 50 | 19 | 39 | 79 | 138 | 195 | 417 | 752 | 1,180 | 2,470 | | |
| 60 | 17 | 35 | 71 | 125 | 177 | 378 | 681 | 1,070 | 2,240 | | |
| 70 | 16 | 32 | 66 | 115 | 163 | 348 | 626 | 988 | 2,060 | | |
| 80 | 15 | 30 | 61 | 107 | 152 | 324 | 583 | 919 | 1,910 | | |
| 90 | 14 | 28 | 57 | 100 | 142 | 304 | 547 | 862 | 1,800 | | |
| 100 | 13 | 27 | 54 | 95 | 134 | 287 | 517 | 814 | 1,700 | | |
| 125 | 11 | 24 | 48 | 84 | 119 | 254 | 458 | 722 | 1,500 | | |
| 150 | 10 | 21 | 44 | 76 | 108 | 230 | 415 | 654 | 1,360 | | |
| 175 | NA | 20 | 40 | 70 | 99 | 212 | 382 | 602 | 1,250 | | |
| 200 | NA | 18 | 37 | 65 | 92 | 197 | 355 | 560 | 1,170 | | |
| 250 | NA | 16 | 33 | 58 | 82 | 175 | 315 | 496 | 1,030 | | |
| 300 | NA | 15 | 30 | 52 | 74 | 158 | 285 | 449 | 936 | | |
| 350 | NA | 14 | 28 | 48 | 68 | 146 | 262 | 414 | 861 | | |
| 400 | NA | 13 | 26 | 45 | 63 | 136 | 244 | 385 | 801 | | |
| 450 | NA | 12 | 24 | 42 | 60 | 127 | 229 | 361 | 752 | | |
| 500 | NA | 11 | 23 | 40 | 56 | 120 | 216 | 341 | 710 | | |
| 550 | NA | 11 | 22 | 38 | 53 | 114 | 205 | 324 | 674 | | |
| 600 | NA | 10 | 21 | 36 | 51 | 109 | 196 | 309 | 643 | | |
| 650 | NA | NA | 20 | 34 | 49 | 104 | 188 | 296 | 616 | | |
| 700 | NA | NA | 19 | 33 | 47 | 100 | 180 | 284 | 592 | | |
| 750 | NA | NA | 18 | 32 | 45 | 96 | 174 | 274 | 570 | | |
| 800 | NA | NA | 18 | 31 | 44 | 93 | 168 | 264 | 551 | | |
| 850 | NA | NA | 17 | 30 | 42 | 90 | 162 | 256 | 533 | | |
| 900 | NA | NA | 17 | 29 | 41 | 87 | 157 | 248 | 517 | | |
| 950 | NA | NA | 16 | 28 | 40 | 85 | 153 | 241 | 502 | | |
| 1,000 | NA | NA | 16 | 27 | 39 | 83 | 149 | 234 | 488 | | |
| 1,100 | NA | NA | 15 | 26 | 37 | 78 | 141 | 223 | 464 | | |
| 1,200 | NA | NA | 14 | 25 | 35 | 75 | 135 | 212 | 442 | | |
| 1,300 | NA | NA | 14 | 24 | 34 | 72 | 129 | 203 | 423 | | |
| 1,400 | NA | NA | 13 | 23 | 32 | 69 | 124 | 195 | 407 | | |
| 1,500 | NA | NA | 13 | 22 | 31 | 66 | 119 | 188 | 392 | | |
| 1,600 | NA | NA | 12 | 21 | 30 | 64 | 115 | 182 | 378 | | |
| 1,700 | NA | NA | 12 | 20 | 29 | 62 | 112 | 176 | 366 | | |
| 1,800 | NA | NA | 11 | 20 | 28 | 60 | 108 | 170 | 355 | | |
| 1,900 | NA | NA | 11 | 19 | 27 | 58 | 105 | 166 | 345 | | |
| 2,000 | NA | NA | 11 | 19 | 27 | 57 | 102 | 161 | 335 | | |

NA: A flow of less than 10,000 Btu/hr.

Note: All table entries are rounded to 3 significant digits.

*Table capacities are based on Type K copper tubing inside diameter (shown), which has the smallest inside diameter of the copper tubing products.

Table 6.3.1(g) Semirigid Copper Tubing

| | | | | | | | | | | Gas: | Undiluted Propane |
|--------------------------------------------------------------------------------------|--------|---------------------------------------|-------|-------|-------|-------|--------|--------|--------|-------------------|-------------------|
| | | | | | | | | | | Inlet Pressure: | 2.0 psi |
| | | | | | | | | | | Pressure Drop: | 1.0 psi |
| | | | | | | | | | | Specific Gravity: | 1.50 |
| INTENDED USE: Tube Sizing Between 2 psig Service and Line Pressure Regulator. | | | | | | | | | | | |
| Tube Size (in.) | | | | | | | | | | | |
| Nominal: | K & L: | ¼ | ⅜ | ½ | ⅝ | ¾ | 1 | 1¼ | 1½ | 2 | |
| | ACR: | ⅜ | ½ | ⅝ | ¾ | ⅞ | 1⅛ | 1⅜ | — | — | |
| Outside: | | 0.375 | 0.500 | 0.625 | 0.750 | 0.875 | 1.125 | 1.375 | 1.625 | 2.125 | |
| Inside:* | | 0.305 | 0.402 | 0.527 | 0.652 | 0.745 | 0.995 | 1.245 | 1.481 | 1.959 | |
| Length (ft) | | Capacity in Thousands of Btu per Hour | | | | | | | | | |
| 10 | 413 | 852 | 1,730 | 3,030 | 4,300 | 9,170 | 16,500 | 26,000 | 54,200 | | |
| 20 | 284 | 585 | 1,190 | 2,080 | 2,950 | 6,310 | 11,400 | 17,900 | 37,300 | | |
| 30 | 228 | 470 | 956 | 1,670 | 2,370 | 5,060 | 9,120 | 14,400 | 29,900 | | |
| 40 | 195 | 402 | 818 | 1,430 | 2,030 | 4,330 | 7,800 | 12,300 | 25,600 | | |
| 50 | 173 | 356 | 725 | 1,270 | 1,800 | 3,840 | 6,920 | 10,900 | 22,700 | | |
| 60 | 157 | 323 | 657 | 1,150 | 1,630 | 3,480 | 6,270 | 9,880 | 20,600 | | |
| 70 | 144 | 297 | 605 | 1,060 | 1,500 | 3,200 | 5,760 | 9,090 | 18,900 | | |
| 80 | 134 | 276 | 562 | 983 | 1,390 | 2,980 | 5,360 | 8,450 | 17,600 | | |
| 90 | 126 | 259 | 528 | 922 | 1,310 | 2,790 | 5,030 | 7,930 | 16,500 | | |
| 100 | 119 | 245 | 498 | 871 | 1,240 | 2,640 | 4,750 | 7,490 | 15,600 | | |
| 125 | 105 | 217 | 442 | 772 | 1,100 | 2,340 | 4,210 | 6,640 | 13,800 | | |
| 150 | 95 | 197 | 400 | 700 | 992 | 2,120 | 3,820 | 6,020 | 12,500 | | |
| 175 | 88 | 181 | 368 | 644 | 913 | 1,950 | 3,510 | 5,540 | 11,500 | | |
| 200 | 82 | 168 | 343 | 599 | 849 | 1,810 | 3,270 | 5,150 | 10,700 | | |
| 250 | 72 | 149 | 304 | 531 | 753 | 1,610 | 2,900 | 4,560 | 9,510 | | |
| 300 | 66 | 135 | 275 | 481 | 682 | 1,460 | 2,620 | 4,140 | 8,610 | | |
| 350 | 60 | 124 | 253 | 442 | 628 | 1,340 | 2,410 | 3,800 | 7,920 | | |
| 400 | 56 | 116 | 235 | 411 | 584 | 1,250 | 2,250 | 3,540 | 7,370 | | |
| 450 | 53 | 109 | 221 | 386 | 548 | 1,170 | 2,110 | 3,320 | 6,920 | | |
| 500 | 50 | 103 | 209 | 365 | 517 | 1,110 | 1,990 | 3,140 | 6,530 | | |
| 550 | 47 | 97 | 198 | 346 | 491 | 1,050 | 1,890 | 2,980 | 6,210 | | |
| 600 | 45 | 93 | 189 | 330 | 469 | 1,000 | 1,800 | 2,840 | 5,920 | | |
| 650 | 43 | 89 | 181 | 316 | 449 | 959 | 1,730 | 2,720 | 5,670 | | |
| 700 | 41 | 86 | 174 | 304 | 431 | 921 | 1,660 | 2,620 | 5,450 | | |
| 750 | 40 | 82 | 168 | 293 | 415 | 888 | 1,600 | 2,520 | 5,250 | | |
| 800 | 39 | 80 | 162 | 283 | 401 | 857 | 1,540 | 2,430 | 5,070 | | |
| 850 | 37 | 77 | 157 | 274 | 388 | 829 | 1,490 | 2,350 | 4,900 | | |
| 900 | 36 | 75 | 152 | 265 | 376 | 804 | 1,450 | 2,280 | 4,750 | | |
| 950 | 35 | 72 | 147 | 258 | 366 | 781 | 1,410 | 2,220 | 4,620 | | |
| 1,000 | 34 | 71 | 143 | 251 | 356 | 760 | 1,370 | 2,160 | 4,490 | | |
| 1,100 | 32 | 67 | 136 | 238 | 338 | 721 | 1,300 | 2,050 | 4,270 | | |
| 1,200 | 31 | 64 | 130 | 227 | 322 | 688 | 1,240 | 1,950 | 4,070 | | |
| 1,300 | 30 | 61 | 124 | 217 | 309 | 659 | 1,190 | 1,870 | 3,900 | | |
| 1,400 | 28 | 59 | 120 | 209 | 296 | 633 | 1,140 | 1,800 | 3,740 | | |
| 1,500 | 27 | 57 | 115 | 201 | 286 | 610 | 1,100 | 1,730 | 3,610 | | |
| 1,600 | 26 | 55 | 111 | 194 | 276 | 589 | 1,060 | 1,670 | 3,480 | | |
| 1,700 | 26 | 53 | 108 | 188 | 267 | 570 | 1,030 | 1,620 | 3,370 | | |
| 1,800 | 25 | 51 | 104 | 182 | 259 | 553 | 1,000 | 1,570 | 3,270 | | |
| 1,900 | 24 | 50 | 101 | 177 | 251 | 537 | 966 | 1,520 | 3,170 | | |
| 2,000 | 23 | 48 | 99 | 172 | 244 | 522 | 940 | 1,480 | 3,090 | | |

Note: All table entries are rounded to 3 significant digits.

*Table capacities are based on Type K copper tubing inside diameter (shown), which has the smallest inside diameter of the copper tubing products.

Table 6.3.1(h) Corrugated Stainless Steel Tubing (CSST)

| Gas: Undiluted Propane | | | | | | | | | | | | | | |
|------------------------------------------------------------------------------------------------------------------------|----------------------------------------------|----|-----|-----|-----|-----|-----|-----|-------|-------|-------|-------|-------|-------|
| Inlet Pressure: 11.0 in. w.c. | | | | | | | | | | | | | | |
| Pressure Drop: 0.5 in. w.c. | | | | | | | | | | | | | | |
| Specific Gravity: 1.50 | | | | | | | | | | | | | | |
| INTENDED USE: CSST Sizing Between Single- or Second-Stage (Low-Pressure) Regulator and Appliance Shutoff Valve. | | | | | | | | | | | | | | |
| Tube Size (EHD) | | | | | | | | | | | | | | |
| Flow Designation: | 13 | 15 | 18 | 19 | 23 | 25 | 30 | 31 | 37 | 39 | 46 | 48 | 60 | 62 |
| Length (ft) | Capacity in Thousands of Btu per Hour | | | | | | | | | | | | | |
| 5 | 72 | 99 | 181 | 211 | 355 | 426 | 744 | 863 | 1,420 | 1,638 | 2,830 | 3,270 | 5,780 | 6,550 |
| 10 | 50 | 69 | 129 | 150 | 254 | 303 | 521 | 605 | 971 | 1,179 | 1,990 | 2,320 | 4,110 | 4,640 |
| 15 | 39 | 55 | 104 | 121 | 208 | 248 | 422 | 490 | 775 | 972 | 1,620 | 1,900 | 3,370 | 3,790 |
| 20 | 34 | 49 | 91 | 106 | 183 | 216 | 365 | 425 | 661 | 847 | 1,400 | 1,650 | 2,930 | 3,290 |
| 25 | 30 | 42 | 82 | 94 | 164 | 192 | 325 | 379 | 583 | 762 | 1,250 | 1,480 | 2,630 | 2,940 |
| 30 | 28 | 39 | 74 | 87 | 151 | 177 | 297 | 344 | 528 | 698 | 1,140 | 1,350 | 2,400 | 2,680 |
| 40 | 23 | 33 | 64 | 74 | 131 | 153 | 256 | 297 | 449 | 610 | 988 | 1,170 | 2,090 | 2,330 |
| 50 | 20 | 30 | 58 | 66 | 118 | 137 | 227 | 265 | 397 | 548 | 884 | 1,050 | 1,870 | 2,080 |
| 60 | 19 | 26 | 53 | 60 | 107 | 126 | 207 | 241 | 359 | 502 | 805 | 961 | 1,710 | 1,900 |
| 70 | 17 | 25 | 49 | 57 | 99 | 117 | 191 | 222 | 330 | 466 | 745 | 890 | 1,590 | 1,760 |
| 80 | 15 | 23 | 45 | 52 | 94 | 109 | 178 | 208 | 307 | 438 | 696 | 833 | 1,490 | 1,650 |
| 90 | 15 | 22 | 44 | 50 | 90 | 102 | 169 | 197 | 286 | 414 | 656 | 787 | 1,400 | 1,550 |
| 100 | 14 | 20 | 41 | 47 | 85 | 98 | 159 | 186 | 270 | 393 | 621 | 746 | 1,330 | 1,480 |
| 150 | 11 | 15 | 31 | 36 | 66 | 75 | 123 | 143 | 217 | 324 | 506 | 611 | 1,090 | 1,210 |
| 200 | 9 | 14 | 28 | 33 | 60 | 69 | 112 | 129 | 183 | 283 | 438 | 531 | 948 | 1,050 |
| 250 | 8 | 12 | 25 | 30 | 53 | 61 | 99 | 117 | 163 | 254 | 390 | 476 | 850 | 934 |
| 300 | 8 | 11 | 23 | 26 | 50 | 57 | 90 | 107 | 147 | 234 | 357 | 434 | 777 | 854 |

EHD: Equivalent hydraulic diameter. A measure of the relative hydraulic efficiency between different tubing sizes. The greater the value of EHD, the greater the gas capacity of the tubing.

- Notes:
- (1) Table includes losses for four 90 degree bends and two end fittings. Tubing runs with larger numbers of bends and/or fittings shall be increased by an equivalent length of tubing to the following equation: $L = 1.3n$, where L is additional length (ft) of tubing and n is the number of additional fittings and/or bends.
 - (2) All table entries are rounded to 3 significant digits.

Table 6.3.1(i) Corrugated Stainless Steel Tubing (CSST)

| | | | | | | | | | | | | | | Gas: | Undiluted Propane |
|-------------------------------------------------------------------------------|---------------------------------------|-----|-----|-------|-------|-------|-------|-------|-------|-------|--------|--------|--------|-------------------|-------------------|
| | | | | | | | | | | | | | | Inlet Pressure: | 2.0 psi |
| | | | | | | | | | | | | | | Pressure Drop: | 1.0 psi |
| | | | | | | | | | | | | | | Specific Gravity: | 1.50 |
| INTENDED USE: CSST Sizing Between 2 psig Service and Line Pressure Regulator. | | | | | | | | | | | | | | | |
| | | | | | | | | | | | | | | Tube Size (EHD) | |
| Flow Designation: | 13 | 15 | 18 | 19 | 23 | 25 | 30 | 31 | 37 | 39 | 46 | 48 | 60 | 62 | |
| Length (ft) | Capacity in Thousands of Btu per Hour | | | | | | | | | | | | | | |
| 10 | 426 | 558 | 927 | 1,110 | 1,740 | 2,170 | 4,100 | 4,720 | 7,130 | 7,958 | 15,200 | 16,800 | 29,400 | 34,200 | |
| 25 | 262 | 347 | 591 | 701 | 1,120 | 1,380 | 2,560 | 2,950 | 4,560 | 5,147 | 9,550 | 10,700 | 18,800 | 21,700 | |
| 30 | 238 | 316 | 540 | 640 | 1,030 | 1,270 | 2,330 | 2,690 | 4,180 | 4,719 | 8,710 | 9,790 | 17,200 | 19,800 | |
| 40 | 203 | 271 | 469 | 554 | 896 | 1,100 | 2,010 | 2,320 | 3,630 | 4,116 | 7,530 | 8,500 | 14,900 | 17,200 | |
| 50 | 181 | 243 | 420 | 496 | 806 | 986 | 1,790 | 2,070 | 3,260 | 3,702 | 6,730 | 7,610 | 13,400 | 15,400 | |
| 75 | 147 | 196 | 344 | 406 | 663 | 809 | 1,460 | 1,690 | 2,680 | 3,053 | 5,480 | 6,230 | 11,000 | 12,600 | |
| 80 | 140 | 189 | 333 | 393 | 643 | 768 | 1,410 | 1,630 | 2,590 | 2,961 | 5,300 | 6,040 | 10,600 | 12,200 | |
| 100 | 124 | 169 | 298 | 350 | 578 | 703 | 1,260 | 1,450 | 2,330 | 2,662 | 4,740 | 5,410 | 9,530 | 10,900 | |
| 150 | 101 | 137 | 245 | 287 | 477 | 575 | 1,020 | 1,180 | 1,910 | 2,195 | 3,860 | 4,430 | 7,810 | 8,890 | |
| 200 | 86 | 118 | 213 | 248 | 415 | 501 | 880 | 1,020 | 1,660 | 1,915 | 3,340 | 3,840 | 6,780 | 7,710 | |
| 250 | 77 | 105 | 191 | 222 | 373 | 448 | 785 | 910 | 1,490 | 1,722 | 2,980 | 3,440 | 6,080 | 6,900 | |
| 300 | 69 | 96 | 173 | 203 | 343 | 411 | 716 | 829 | 1,360 | 1,578 | 2,720 | 3,150 | 5,560 | 6,300 | |
| 400 | 60 | 82 | 151 | 175 | 298 | 355 | 616 | 716 | 1,160 | 1,376 | 2,350 | 2,730 | 4,830 | 5,460 | |
| 500 | 53 | 72 | 135 | 158 | 268 | 319 | 550 | 638 | 1,030 | 1,237 | 2,100 | 2,450 | 4,330 | 4,880 | |

EHD: Equivalent hydraulic diameter. A measure of the relative hydraulic efficiency between different tubing sizes. The greater the value of EHD, the greater the gas capacity of the tubing.

Notes:

- (1) Table does not include effect of pressure drop across the line regulator. Where regulator loss exceeds $\frac{1}{2}$ psi (based on 13 in. w.c. outlet pressure), do not use this table. Consult with regulator manufacturer for pressure drops and capacity factors. Pressure drops across a regulator may vary with flow rate.
- (2) CAUTION: Capacities shown in table may exceed maximum capacity for a selected regulator. Consult with regulator or tubing manufacturer for guidance.
- (3) Table includes losses for four 90 degree bends and two end fittings. Tubing runs with larger number of bends and/or fittings shall be increased by an equivalent length of tubing according to the following equation: $L = 1.3n$, where L is additional length (ft) of tubing and n is the number of additional fittings and/or bends.
- (4) All table entries are rounded to 3 significant digits.

Table 6.3.1(j) Corrugated Stainless Steel Tubing (CSST)

| | | | | | | | | | | | | | | Gas: | Undiluted Propane | | | | | | | | |
|-------------------|---------------------------------------|-------|-------|-------|-------|-------|-------|-------|--------|--------|--------|--------|--------|-------------------|-------------------|--|--|--|--|--|--|--|--|
| | | | | | | | | | | | | | | Inlet Pressure: | 5.0 psi | | | | | | | | |
| | | | | | | | | | | | | | | Pressure Drop: | 3.5 psi | | | | | | | | |
| | | | | | | | | | | | | | | Specific Gravity: | 1.50 | | | | | | | | |
| | | | | | | | | | | | | | | Tube Size (EHD) | | | | | | | | | |
| Flow Designation: | 13 | 15 | 18 | 19 | 23 | 25 | 30 | 31 | 37 | 39 | 46 | 48 | 60 | 62 | | | | | | | | | |
| Length (ft) | Capacity in Thousands of Btu per Hour | | | | | | | | | | | | | | | | | | | | | | |
| 10 | 826 | 1,070 | 1,710 | 2,060 | 3,150 | 4,000 | 7,830 | 8,950 | 13,100 | 14,441 | 28,600 | 31,200 | 54,400 | 63,800 | | | | | | | | | |
| 25 | 509 | 664 | 1,090 | 1,310 | 2,040 | 2,550 | 4,860 | 5,600 | 8,400 | 9,339 | 18,000 | 19,900 | 34,700 | 40,400 | | | | | | | | | |
| 30 | 461 | 603 | 999 | 1,190 | 1,870 | 2,340 | 4,430 | 5,100 | 7,680 | 8,564 | 16,400 | 18,200 | 31,700 | 36,900 | | | | | | | | | |
| 40 | 396 | 520 | 867 | 1,030 | 1,630 | 2,030 | 3,820 | 4,400 | 6,680 | 7,469 | 14,200 | 15,800 | 27,600 | 32,000 | | | | | | | | | |
| 50 | 352 | 463 | 777 | 926 | 1,460 | 1,820 | 3,410 | 3,930 | 5,990 | 6,717 | 12,700 | 14,100 | 24,700 | 28,600 | | | | | | | | | |
| 75 | 284 | 376 | 637 | 757 | 1,210 | 1,490 | 2,770 | 3,190 | 4,920 | 5,539 | 10,300 | 11,600 | 20,300 | 23,400 | | | | | | | | | |
| 80 | 275 | 363 | 618 | 731 | 1,170 | 1,450 | 2,680 | 3,090 | 4,770 | 5,372 | 9,990 | 11,200 | 19,600 | 22,700 | | | | | | | | | |
| 100 | 243 | 324 | 553 | 656 | 1,050 | 1,300 | 2,390 | 2,760 | 4,280 | 4,830 | 8,930 | 10,000 | 17,600 | 20,300 | | | | | | | | | |
| 150 | 196 | 262 | 453 | 535 | 866 | 1,060 | 1,940 | 2,240 | 3,510 | 3,983 | 7,270 | 8,210 | 14,400 | 16,600 | | | | | | | | | |
| 200 | 169 | 226 | 393 | 464 | 755 | 923 | 1,680 | 1,930 | 3,050 | 3,474 | 6,290 | 7,130 | 12,500 | 14,400 | | | | | | | | | |
| 250 | 150 | 202 | 352 | 415 | 679 | 828 | 1,490 | 1,730 | 2,740 | 3,124 | 5,620 | 6,390 | 11,200 | 12,900 | | | | | | | | | |
| 300 | 136 | 183 | 322 | 379 | 622 | 757 | 1,360 | 1,570 | 2,510 | 2,865 | 5,120 | 5,840 | 10,300 | 11,700 | | | | | | | | | |
| 400 | 117 | 158 | 279 | 328 | 542 | 657 | 1,170 | 1,360 | 2,180 | 2,498 | 4,430 | 5,070 | 8,920 | 10,200 | | | | | | | | | |
| 500 | 104 | 140 | 251 | 294 | 488 | 589 | 1,050 | 1,210 | 1,950 | 2,247 | 3,960 | 4,540 | 8,000 | 9,110 | | | | | | | | | |

EHD: Equivalent hydraulic diameter. A measure of the relative hydraulic efficiency between different tubing sizes. The greater the value of EHD, the greater the gas capacity of the tubing.

- Notes:
- (1) Table does not include effect of pressure drop across the line regulator. Where regulator loss exceeds 1/2 psi (based on 13 in. w.c. outlet pressure), do not use this table. Consult with regulator manufacturer for pressure drops and capacity factors. Pressure drops across a regulator may vary with flow rate.
 - (2) CAUTION: Capacities shown in table may exceed maximum capacity for a selected regulator. Consult with regulator or tubing manufacturer for guidance.
 - (3) Table includes losses for four 90 degree bends and two end fittings. Tubing runs with larger number of bends and/or fittings shall be increased by an equivalent length of tubing according to the following equation: $L = 1.3n$, where L is additional length (ft) of tubing and n is the number of additional fittings and/or bends.
 - (4) All table entries are rounded to 3 significant digits.

Table 6.3.1(k) Polyethylene Plastic Pipe

| | | Gas: Undiluted Propane | | | | | | |
|--------------------------------------------------------------------------------------------------------------------------------------------|----------------------------------------------|--------------------------------------|---------------|-----------------|-----------------|---------------|---------------|---------------|
| | | Inlet Pressure: 11.0 in. w.c. | | | | | | |
| | | Pressure Drop: 0.5 in. w.c. | | | | | | |
| | | Specific Gravity: 1.50 | | | | | | |
| INTENDED USE: PE Pipe Sizing Between Integral Second-Stage Regulator at Tank or Second-Stage (Low-Pressure) Regulator and Building. | | | | | | | | |
| Nominal OD: | Pipe Size (in.) | | | | | | | |
| | $\frac{1}{2}$ | $\frac{3}{4}$ | 1 | 1 $\frac{1}{4}$ | 1 $\frac{1}{2}$ | 2 | 3 | 4 |
| Designation: | SDR 9.3 | SDR 11 | SDR 11 | SDR 10 | SDR 11 | SDR 11 | SDR 11 | SDR 11 |
| Actual ID: | 0.660 | 0.860 | 1.077 | 1.328 | 1.554 | 1.943 | 2.864 | 3.682 |
| Length (ft) | Capacity in Thousands of Btu per Hour | | | | | | | |
| 10 | 340 | 680 | 1,230 | 2,130 | 3,210 | 5,770 | 16,000 | 30,900 |
| 20 | 233 | 468 | 844 | 1,460 | 2,210 | 3,970 | 11,000 | 21,200 |
| 30 | 187 | 375 | 677 | 1,170 | 1,770 | 3,180 | 8,810 | 17,000 |
| 40 | 160 | 321 | 580 | 1,000 | 1,520 | 2,730 | 7,540 | 14,600 |
| 50 | 142 | 285 | 514 | 890 | 1,340 | 2,420 | 6,680 | 12,900 |
| 60 | 129 | 258 | 466 | 807 | 1,220 | 2,190 | 6,050 | 11,700 |
| 70 | 119 | 237 | 428 | 742 | 1,120 | 2,010 | 5,570 | 10,800 |
| 80 | 110 | 221 | 398 | 690 | 1,040 | 1,870 | 5,180 | 10,000 |
| 90 | 103 | 207 | 374 | 648 | 978 | 1,760 | 4,860 | 9,400 |
| 100 | 98 | 196 | 353 | 612 | 924 | 1,660 | 4,590 | 8,900 |
| 125 | 87 | 173 | 313 | 542 | 819 | 1,470 | 4,070 | 7,900 |
| 150 | 78 | 157 | 284 | 491 | 742 | 1,330 | 3,690 | 7,130 |
| 175 | 72 | 145 | 261 | 452 | 683 | 1,230 | 3,390 | 6,560 |
| 200 | 67 | 135 | 243 | 420 | 635 | 1,140 | 3,160 | 6,100 |
| 250 | 60 | 119 | 215 | 373 | 563 | 1,010 | 2,800 | 5,410 |
| 300 | 54 | 108 | 195 | 338 | 510 | 916 | 2,530 | 4,900 |
| 350 | 50 | 99 | 179 | 311 | 469 | 843 | 2,330 | 4,510 |
| 400 | 46 | 92 | 167 | 289 | 436 | 784 | 2,170 | 4,190 |
| 450 | 43 | 87 | 157 | 271 | 409 | 736 | 2,040 | 3,930 |
| 500 | 41 | 82 | 148 | 256 | 387 | 695 | 1,920 | 3,720 |

Note: All table entries are rounded to 3 significant digits.

Table 6.3.1(l) Polyethylene Plastic Pipe

| | | Gas: Undiluted Propane | | | | | | |
|-------------------------------------------------------------------------------------------|---------------------------------------|-------------------------|--------|--------|--------|--------|---------|---------|
| | | Inlet Pressure: 2.0 psi | | | | | | |
| | | Pressure Drop: 1.0 psi | | | | | | |
| | | Specific Gravity: 1.50 | | | | | | |
| INTENDED USE: PE Pipe Sizing Between 2 psi Service Regulator and Line Pressure Regulator. | | | | | | | | |
| | | Pipe Size (in.) | | | | | | |
| Nominal OD: | ½ | ¾ | 1 | 1¼ | 1½ | 2 | 3 | 4 |
| Designation: | SDR 9.3 | SDR 11 | SDR 11 | SDR 10 | SDR 11 | SDR 11 | SDR 11 | SDR 11 |
| Actual ID: | 0.660 | 0.860 | 1.077 | 1.328 | 1.554 | 1.943 | 2.864 | 3.682 |
| Length (ft) | Capacity in Thousands of Btu per Hour | | | | | | | |
| 10 | 3,130 | 6,260 | 11,300 | 19,600 | 29,500 | 53,100 | 147,000 | 284,000 |
| 20 | 2,150 | 4,300 | 7,760 | 13,400 | 20,300 | 36,500 | 101,000 | 195,000 |
| 30 | 1,730 | 3,450 | 6,230 | 10,800 | 16,300 | 29,300 | 81,100 | 157,000 |
| 40 | 1,480 | 2,960 | 5,330 | 9,240 | 14,000 | 25,100 | 69,400 | 134,100 |
| 50 | 1,310 | 2,620 | 4,730 | 8,190 | 12,400 | 22,200 | 61,500 | 119,000 |
| 60 | 1,190 | 2,370 | 4,280 | 7,420 | 11,200 | 20,100 | 55,700 | 108,000 |
| 70 | 1,090 | 2,180 | 3,940 | 6,830 | 10,300 | 18,500 | 51,300 | 99,100 |
| 80 | 1,010 | 2,030 | 3,670 | 6,350 | 9,590 | 17,200 | 47,700 | 92,200 |
| 90 | 952 | 1,910 | 3,440 | 5,960 | 9,000 | 16,200 | 44,700 | 86,500 |
| 100 | 899 | 1,800 | 3,250 | 5,630 | 8,500 | 15,300 | 42,300 | 81,700 |
| 125 | 797 | 1,600 | 2,880 | 4,990 | 7,530 | 13,500 | 37,500 | 72,400 |
| 150 | 722 | 1,450 | 2,610 | 4,520 | 6,830 | 12,300 | 33,900 | 65,600 |
| 175 | 664 | 1,330 | 2,400 | 4,160 | 6,280 | 11,300 | 31,200 | 60,300 |
| 200 | 618 | 1,240 | 2,230 | 3,870 | 5,840 | 10,500 | 29,000 | 56,100 |
| 250 | 548 | 1,100 | 1,980 | 3,430 | 5,180 | 9,300 | 25,700 | 49,800 |
| 300 | 496 | 994 | 1,790 | 3,110 | 4,690 | 8,430 | 23,300 | 45,100 |
| 350 | 457 | 914 | 1,650 | 2,860 | 4,320 | 7,760 | 21,500 | 41,500 |
| 400 | 425 | 851 | 1,530 | 2,660 | 4,020 | 7,220 | 20,000 | 38,600 |
| 450 | 399 | 798 | 1,440 | 2,500 | 3,770 | 6,770 | 18,700 | 36,200 |
| 500 | 377 | 754 | 1,360 | 2,360 | 3,560 | 6,390 | 17,700 | 34,200 |
| 550 | 358 | 716 | 1,290 | 2,240 | 3,380 | 6,070 | 16,800 | 32,500 |
| 600 | 341 | 683 | 1,230 | 2,140 | 3,220 | 5,790 | 16,000 | 31,000 |
| 650 | 327 | 654 | 1,180 | 2,040 | 3,090 | 5,550 | 15,400 | 29,700 |
| 700 | 314 | 628 | 1,130 | 1,960 | 2,970 | 5,330 | 14,700 | 28,500 |
| 750 | 302 | 605 | 1,090 | 1,890 | 2,860 | 5,140 | 14,200 | 27,500 |
| 800 | 292 | 585 | 1,050 | 1,830 | 2,760 | 4,960 | 13,700 | 26,500 |
| 850 | 283 | 566 | 1,020 | 1,770 | 2,670 | 4,800 | 13,300 | 25,700 |
| 900 | 274 | 549 | 990 | 1,710 | 2,590 | 4,650 | 12,900 | 24,900 |
| 950 | 266 | 533 | 961 | 1,670 | 2,520 | 4,520 | 12,500 | 24,200 |
| 1,000 | 259 | 518 | 935 | 1,620 | 2,450 | 4,400 | 12,200 | 23,500 |
| 1,100 | 246 | 492 | 888 | 1,540 | 2,320 | 4,170 | 11,500 | 22,300 |
| 1,200 | 234 | 470 | 847 | 1,470 | 2,220 | 3,980 | 11,000 | 21,300 |
| 1,300 | 225 | 450 | 811 | 1,410 | 2,120 | 3,810 | 10,600 | 20,400 |
| 1,400 | 216 | 432 | 779 | 1,350 | 2,040 | 3,660 | 10,100 | 19,600 |
| 1,500 | 208 | 416 | 751 | 1,300 | 1,960 | 3,530 | 9,760 | 18,900 |
| 1,600 | 201 | 402 | 725 | 1,260 | 1,900 | 3,410 | 9,430 | 18,200 |
| 1,700 | 194 | 389 | 702 | 1,220 | 1,840 | 3,300 | 9,130 | 17,600 |
| 1,800 | 188 | 377 | 680 | 1,180 | 1,780 | 3,200 | 8,850 | 17,100 |
| 1,900 | 183 | 366 | 661 | 1,140 | 1,730 | 3,110 | 8,590 | 16,600 |
| 2,000 | 178 | 356 | 643 | 1,110 | 1,680 | 3,020 | 8,360 | 16,200 |

Note: All table entries are rounded to 3 significant digits.

Table 6.3.1(m) Polyethylene Plastic Tubing

| Gas: Undiluted Propane | | |
|-----------------------------------------------------------------------------------------------------------------------------------|---------------------------------------|--------|
| Inlet Pressure: | 11.0 in. w.c. | |
| Pressure Drop: | 0.5 in. w.c. | |
| Specific Gravity: | 1.50 | |
| INTENDED USE: Sizing Between Integral 2-Stage Regulator at Tank or Second-Stage (Low-Pressure Regulator) and the Building. | | |
| Plastic Tubing Size (CTS) (in.) | | |
| Nominal OD: | ½ | 1 |
| Designation: | SDR 7 | SDR 11 |
| Actual ID: | 0.445 | 0.927 |
| Length (ft) | Capacity in Thousands of Btu per Hour | |
| 10 | 121 | 828 |
| 20 | 83 | 569 |
| 30 | 67 | 457 |
| 40 | 57 | 391 |
| 50 | 51 | 347 |
| 60 | 46 | 314 |
| 70 | 42 | 289 |
| 80 | 39 | 269 |
| 90 | 37 | 252 |
| 100 | 35 | 238 |
| 125 | 31 | 211 |
| 150 | 28 | 191 |
| 175 | 26 | 176 |
| 200 | 24 | 164 |
| 225 | 22 | 154 |
| 250 | 21 | 145 |
| 275 | 20 | 138 |
| 300 | 19 | 132 |
| 350 | 18 | 121 |
| 400 | 16 | 113 |
| 450 | 15 | 106 |
| 500 | 15 | 100 |

CTS: Copper tube size.

Note: All table entries are rounded to 3 significant digits.

6.4.1* Low-Pressure Gas Formula. Less than 1.5 psi (10.3 kPa):

$$D = \frac{Q^{0.381}}{19.17 \left(\frac{\Delta H}{Cr \times L} \right)^{0.206}} \quad [6.4.1]$$

where:

 D = inside diameter of pipe (in.) Q = input rate appliance(s) (cubic feet per hour at 60°F and 30 in. mercury column) ΔH = pressure drop [in. w.c. (27.7 in. H₂O = 1 psi)] L = equivalent length of pipe (ft)See Table 6.4.2 for values of Cr .

6.4.2* High-Pressure Gas Formula. 1.5 psi (10.3 kPa) and above:

$$D = \frac{Q^{0.381}}{18.93 \left[\frac{(P_1^2 - P_2^2) \cdot Y}{Cr \times L} \right]^{0.206}} \quad [6.4.2]$$

where:

 D = inside diameter of pipe (in.) Q = input rate appliance(s) (cubic feet per hour at 60°F and 30 in. mercury column) P_1 = upstream pressure [psia ($P_1 + 14.7$)] P_2 = downstream pressure [psia ($P_2 + 14.7$)] L = equivalent length of pipe (ft)See Table 6.4.2 for values of Cr and Y .**Table 6.4.2 Cr and Y for Natural Gas and Undiluted Propane at Standard Conditions**

| Gas | Formula Factors | |
|-------------------|-----------------|--------|
| | Cr | Y |
| Natural gas | 0.6094 | 0.9992 |
| Undiluted propane | 1.2462 | 0.9910 |

Chapter 7 Gas Piping Installation

7.1 Installation of Underground Piping.

7.1.1 Clearances. Underground gas piping shall be installed with sufficient clearance from any other underground structure to avoid contact therewith, to allow maintenance, and to protect against damage from proximity to other structures. In addition, underground plastic piping shall be installed with sufficient clearance or shall be insulated from any source of heat so as to prevent the heat from impairing the serviceability of the pipe.

7.1.2 Protection Against Damage. Means shall be provided to prevent excessive stressing of the piping where vehicular traffic is heavy or soil conditions are unstable and settling of piping or foundation walls could occur. Piping shall be buried or covered in a manner so as to protect the piping from physical damage. Piping shall be protected from physical damage where it passes through flower beds, shrub beds, and other such cultivated areas where such damage is reasonably expected.

7.1.2.1 Cover Requirements. Underground piping systems shall be installed with a minimum of 12 in. (300 mm) of cover.

(A) The minimum cover shall be increased to 18 in. (460 mm) if external damage to the pipe or tubing from external forces is likely to result.

(B) Where a minimum of 12 in. (300 mm) of cover cannot be provided, the pipe shall be installed in conduit or bridged (shielded).

7.1.2.2 Trenches. The trench shall be graded so that the pipe has a firm, substantially continuous bearing on the bottom of the trench.

7.1.2.3 Backfilling. Where flooding of the trench is done to consolidate the backfill, care shall be exercised to see that the pipe is not floated from its firm bearing on the trench bottom.

7.1.3* Corrosion Protection of Piping. Steel pipe and steel tubing installed underground shall be installed in accordance with the 7.1.3.1 through 7.1.3.9.

7.1.3.1 Zinc coating (galvanizing) shall not be deemed adequate protection for underground gas piping.

7.1.3.2 Underground piping shall comply with one or more of the following unless approved technical justification is provided to demonstrate that protection is unnecessary:

- (1) The piping shall be made of corrosion-resistant material that is suitable for the environment in which it will be installed.
- (2) Pipe shall have a factory-applied, electrically insulating coating. Fittings and joints between sections of coated pipe shall be coated in accordance with the coating manufacturer's instructions.
- (3) The piping shall have a cathodic protection system installed, and the system shall be maintained in accordance with 7.1.3.3 or 7.1.3.6.

7.1.3.3 Cathodic protection systems shall be monitored by testing and the results shall be documented. The test results shall demonstrate one of the following:

- (1) A pipe-to-soil voltage of -0.85 volts or more negative is produced, with reference to a saturated copper-copper sulfate half cell
- (2) A pipe-to-soil voltage of -0.78 volts or more negative is produced, with reference to a saturated KCl calomel half cell
- (3) A pipe-to-soil voltage of -0.80 volts or more negative is produced, with reference to a silver-silver chloride half cell
- (4) Compliance with a method described in Appendix D of Title 49 of the Code of Federal Regulations, Part 192

7.1.3.4 Sacrificial anodes shall be tested in accordance with the following:

- (1) Upon installation of the cathodic protection system, except where prohibited by climatic conditions, in which case the testing shall be performed not later than 180 days after the installation of the system
- (2) 12 to 18 months after the initial test
- (3) Upon successful verification testing in accordance with (1) and (2), periodic follow-up testing shall be performed at intervals not to exceed 36 months

7.1.3.5 Systems failing a test shall be repaired not more than 180 days after the date of the failed testing. The testing schedule shall be restarted as required in 7.1.3.4(1) and (2), and the results shall comply with 7.1.3.3.

7.1.3.6 Impressed current cathodic protection systems shall be inspected and tested in accordance with the following schedule:

- (1) The impressed current rectifier voltage output shall be checked at intervals not exceeding two months.
- (2) The pipe-to-soil voltage shall be tested at least annually.

7.1.3.7 Documentation of the results of the two most recent tests shall be retained.

7.1.3.8 Where dissimilar metals are joined underground, an insulating coupling or fitting shall be used.

7.1.3.9 Steel risers, other than anodeless risers, connected to plastic piping shall be cathodically protected by means of a welded anode.

7.1.4* Protection Against Freezing. Where the formation of hydrates or ice is known to occur, piping shall be protected against freezing.

7.1.5 Piping Through Foundation Wall. Underground piping, where installed through the outer foundation or basement wall of a building, shall be encased in a protective sleeve or protected by an approved device or method. The space between the gas piping and the sleeve and between the sleeve and the wall shall be sealed to prevent entry of gas and water.

7.1.6 Piping Underground Beneath Buildings. Where gas piping is installed underground beneath buildings, the piping shall be either of the following:

- (1) Encased in an approved conduit designed to withstand the imposed loads and installed in accordance with 7.1.6.1 or 7.1.6.2
- (2) A piping/encasement system listed for installation beneath buildings.

7.1.6.1 Conduit with One End Terminating Outdoors. The conduit shall extend into an accessible portion of the building and, at the point where the conduit terminates in the building, the space between the conduit and the gas piping shall be sealed to prevent the possible entrance of any gas leakage. Where the end sealing is of a type that retains the full pressure of the pipe, the conduit shall be designed for the same pressure as the pipe. The conduit shall extend at least 4 in. (100 mm) outside the building, be vented outdoors above finished ground level, and be installed so as to prevent the entrance of water and insects.

7.1.6.2 Conduit with Both Ends Terminating Indoors. Where the conduit originates and terminates within the same building, the conduit shall originate and terminate in an accessible portion of the building and shall not be sealed.

7.1.7 Plastic Piping.

7.1.7.1 Connection of Plastic Piping. Plastic piping shall be installed outdoors, underground only.

Exception No. 1: Plastic piping shall be permitted to terminate aboveground where an anodeless riser is used.

Exception No. 2: Plastic piping shall be permitted to terminate with a wall head adapter aboveground in buildings, including basements, where the plastic piping is inserted in a piping material permitted for use in buildings.

7.1.7.2 Connections Between Metallic and Plastic Piping. Connections made between metallic and plastic piping shall be made with fittings conforming to one of the following:

- (1) ASTM D2513, *Standard Specification for Polyethylene (PE) Gas Pressure Pipe, Tubing, and Fittings*, Category I transition fittings
- (2) ASTM F1973, *Standard Specification for Factory Assembled Anodeless Risers and Transition Fittings in Polyethylene (PE) and Polyamide 11 (PA11) and Polyamide 12 (PA 12) Fuel Gas Distribution Systems*

(3) ASTM F2509, *Standard Specification for Field-Assembled Anodeless Riser Kits for Use on Outside Diameter Controlled Polyethylene Gas Distribution Pipe and Tubing*

7.1.7.3 Tracer Wire. An electrically continuous corrosion-resistant tracer shall be buried with the plastic pipe to facilitate locating.

7.1.7.3.1 The tracer shall be one of the following:

- (1) A product specifically designed for that purpose
- (2) Insulated copper conductor not less than 14 AWG

7.1.7.3.2 Where tracer wire is used, access shall be provided from aboveground or one end of the tracer wire or tape shall be brought aboveground at a building wall or riser.

N 7.1.8 CSST piping systems shall be installed in accordance with this code and the manufacturer's installation instructions.

7.2 Installation of Aboveground Piping.

7.2.1 Piping installed aboveground shall be securely supported and located where it will be protected from physical damage. Where passing through an exterior wall, the piping shall also be protected from corrosion by coating or wrapping with an inert material approved for such applications. The piping shall be sealed around its circumference at the point of the exterior penetration to prevent the entry of water, insects, and rodents. Where piping is encased in a protective pipe sleeve, the annular spaces between the gas piping and the sleeve and between the sleeve and the wall opening shall be sealed.

N 7.2.2 Protective Coating. Where piping is in contact with a material or an atmosphere corrosive to the piping system, the piping and fittings shall be coated with a corrosion-resistant material. Any such coating used on piping or components shall not be considered as adding strength to the system.

7.2.3 Building Structure.

7.2.3.1 The installation of gas piping shall not cause structural stresses within building components to exceed allowable design limits.

7.2.3.2 Approval shall be obtained before any beams or joists are cut or notched.

7.2.4 Gas Piping to Be Sloped. Piping for other than dry gas conditions shall be sloped not less than 1/4 in. in 15 ft (7 mm in 4.6 m) to prevent traps.

7.2.5* Prohibited Locations. Gas piping inside any building shall not be installed in or through a clothes chute, chimney or gas vent, dumbwaiter, elevator shaft, or air duct, other than combustion air ducts.

7.2.6 Hangers, Supports, and Anchors.

7.2.6.1 Piping shall be supported with metal pipe hooks, metal pipe straps, metal bands, metal brackets, metal hangers, or building structural components, suitable for the size of piping, of adequate strength and quality, and located at intervals so as to prevent or damp out excessive vibration. Piping shall be anchored to prevent undue strains on connected appliances and equipment and shall not be supported by other piping. Pipe hangers and supports shall conform to the requirements of ANSI/MSS SP-58, *Pipe Hangers and Supports — Materials, Design Manufacture, Selection, Application, and Installation*.

Δ 7.2.6.2 Spacings of supports in gas piping installations shall not be greater than shown in Table 7.2.6.2. Spacing of supports of CSST shall be in accordance with the CSST manufacturer's instructions.

Δ Table 7.2.6.2 Support of Piping

| Steel Pipe, Nominal Size of Pipe (in.) | Spacing of Supports (ft) | Nominal Size of Tubing Smooth Wall | |
|-------------------------------------------------|--------------------------------|---------------------------------------------|--------------------------------|
| | | (in. O.D.) | Spacing of Supports (ft) |
| 1/2 | 6 | 1/2 | 4 |
| 3/4 or 1 | 8 | 5/8 or 3/4 | 6 |
| 1 1/4 or larger (horizontal) | 10 | 7/8 or 1 (horizontal) | 8 |
| 1 1/4 or larger (vertical) | Every floor level | 1 or larger (vertical) | Every floor level |

For SI units, 1 ft = 0.305 m.

7.2.6.3 Supports, hangers, and anchors shall be installed so as not to interfere with the free expansion and contraction of the piping between anchors. All parts of the supporting system shall be designed and installed so they are not disengaged by movement of the supported piping.

7.2.6.4 Piping on Roof Tops. Gas piping installed on the roof surfaces shall be elevated above the roof surface and shall be supported in accordance with Table 7.2.6.2.

7.2.7 CSST. CSST piping systems shall be installed in accordance with this code and the manufacturer's installation instructions.

7.3 Concealed Piping in Buildings.

7.3.1 General. Gas piping in concealed locations shall be installed in accordance with this section.

7.3.2 Fittings in Concealed Locations. Fittings installed in concealed locations shall be limited to the following types:

- (1) Threaded elbows, tees, couplings, caps, and plugs
- (2) Brazed fittings
- (3) Welded fittings
- (4) Fittings listed to ANSI LC 1/CSA 6.26, *Fuel Gas Piping Systems Using Corrugated Stainless Steel Tubing*, or ANSI LC 4/CSA 6.32, *Press-Connect Metallic Fittings for Use in Fuel Gas Distribution Systems*

7.3.3 Piping in Partitions. Concealed gas piping shall not be located in solid partitions.

7.3.4 Tubing in Partitions. This provision shall not apply to tubing that pierces walls, floors, or partitions. Tubing installed vertically and horizontally inside hollow walls or partitions without protection along its entire concealed length shall meet the following requirements:

- (1) A steel striker barrier not less than 0.0508 in. (1.3 mm) thick, or equivalent, is installed between the tubing and the finished wall and extends at least 4 in. (100 mm) beyond concealed penetrations of plates, firestops, wall studs, and so on.
- (2) The tubing is installed in single runs and is not rigidly secured.

7.3.5 Piping in Floors.

7.3.5.1 Industrial Occupancies. In industrial occupancies, gas piping in solid floors such as concrete shall be laid in channels in the floor and covered to permit access to the piping with a minimum of damage to the building. Where piping in floor channels could be exposed to excessive moisture or corrosive substances, the piping shall be protected in an approved manner.

7.3.5.2 Other Occupancies. In other than industrial occupancies and where approved by the authority having jurisdiction, gas piping embedded in concrete floor slabs constructed with Portland cement shall be surrounded with a minimum of 1½ in. (38 mm) of concrete and shall not be in physical contact with other metallic structures such as reinforcing rods or electrically neutral conductors. All piping, fittings, and risers shall be protected against corrosion in accordance with 7.2.2. Piping shall not be embedded in concrete slabs containing quickset additives or cinder aggregate.

7.3.6 Shutoff Valves in Tubing Systems. Shutoff valves in tubing systems in concealed locations shall be rigidly and securely supported independently of the tubing.

▲ 7.4 Piping in Vertical Chases. Where gas piping exceeding 5 psi (34 kPa) is located within vertical chases in accordance with 5.5.1, the requirements of 7.4.1 through 7.4.3 shall apply.

7.4.1 Pressure Reduction. Where pressure reduction is required in branch connections for compliance with 5.5.1, such reduction shall take place either inside the chase or immediately adjacent to the outside wall of the chase. Regulator venting and downstream overpressure protection shall comply with 5.8.5 and Section 5.9. The regulator shall be accessible for service and repair and vented in accordance with one of the following:

- (1) Where the fuel gas is lighter than air, regulators equipped with a vent limiting means shall be permitted to be vented into the chase. Regulators not equipped with a vent limiting means shall be permitted to be vented either directly to the outdoors or to a point within the top 1 ft (0.3 m) of the chase.
- (2) Where the fuel gas is heavier than air, the regulator vent shall be vented only directly to the outdoors.

7.4.2 Chase Construction. Chase construction shall comply with local building codes with respect to fire resistance and protection of horizontal and vertical openings.

7.4.3* Ventilation. A chase shall be ventilated to the outdoors and only at the top. The opening(s) shall have a minimum free area [in square inches (square meters)] equal to the product of one-half of the maximum pressure in the piping [in pounds per square inch (kilopascals)] times the largest nominal diameter of that piping [in inches (millimeters)], or the cross-sectional area of the chase, whichever is smaller. Where more than one fuel gas piping system is present, the free area for each system shall be calculated and the largest area used.

7.5 Gas Pipe Turns. Changes in direction of gas pipe shall be made by the use of fittings, factory bends, or field bends.

7.5.1 Metallic Pipe. Metallic pipe bends shall comply with the following:

- (1) Bends shall be made only with bending tools and procedures intended for that purpose.

- (2) All bends shall be smooth and free from buckling, cracks, or other evidence of mechanical damage.
- (3) The longitudinal weld of the pipe shall be near the neutral axis of the bend.
- (4) Pipe shall not be bent through an arc of more than 90 degrees.
- (5) The inside radius of a bend shall be not less than 6 times the outside diameter of the pipe.

7.5.2 Plastic Pipe. Plastic pipe bends shall comply with the following:

- (1) The pipe shall not be damaged, and the internal diameter of the pipe shall not be effectively reduced.
- (2) Joints shall not be located in pipe bends.
- (3) The radius of the inner curve of such bends shall not be less than 25 times the inside diameter of the pipe.
- (4) Where the piping manufacturer specifies the use of special bending tools or procedures, such tools or procedures shall be used.

7.5.3 Elbows. Factory-made welding elbows or transverse segments cut therefrom shall have an arc length measured along the crotch of at least 1 in. (25 mm) for pipe sizes 2 in. (50 mm) and larger.

7.6 Drips and Sediment Traps.

7.6.1 Provide Drips Where Necessary. For other than dry gas conditions, a drip shall be provided at any point in the line of pipe where condensate could collect. Where required by the authority having jurisdiction or the serving gas supplier, a drip shall also be provided at the outlet of the meter. This drip shall be installed so as to constitute a trap wherein an accumulation of condensate shuts off the flow of gas before it runs back into the meter.

7.6.2 Location of Drips. All drips shall be installed only in such locations that they are readily accessible to permit cleaning or emptying. A drip shall not be located where the condensate is likely to freeze.

7.6.3 Sediment Traps. The installation of sediment traps shall be in accordance with 9.6.8.

7.7 Outlets.

7.7.1 Location and Installation.

7.7.1.1 The outlet fittings or piping shall be securely fastened in place.

7.7.1.2 Outlets shall not be located behind doors.

7.7.1.3 Outlets shall be located far enough from floors, walls, patios, slabs, and ceilings to permit the use of wrenches without straining, bending, or damaging the piping.

7.7.1.4 The unthreaded portion of gas piping outlets shall extend not less than 1 in. (25 mm) through finished ceilings or indoor or outdoor walls.

7.7.1.5 The unthreaded portion of gas piping outlets shall extend not less than 2 in. (50 mm) above the surface of floors or outdoor patios or slabs.

7.7.1.6 The provisions of 7.7.1.4 and 7.7.1.5 shall not apply to listed quick-disconnect devices of the flush-mounted type or listed gas convenience outlets. Such devices shall be installed in accordance with the manufacturers' installation instructions.

7.7.2 Cap All Outlets.

- ▲ 7.7.2.1 Each outlet, including a valve, shall be closed gastight with a threaded plug or cap immediately after installation and shall be left closed until the appliance or equipment is connected thereto. When an appliance or equipment is disconnected from an outlet and the outlet is not to be used again immediately, it shall be capped or plugged gastight.

Exception No. 1: Laboratory appliances installed in accordance with 9.6.2(1) shall be permitted.

Exception No. 2: The use of a listed quick-disconnect device with integral shutoff or listed gas convenience outlet shall be permitted.

7.7.2.2 Appliance shutoff valves installed in fireplaces shall be removed and the piping capped gastight where the fireplace is used for solid fuel burning.

7.8 Manual Gas Shutoff Valves.

7.8.1 Valves at Regulators. An accessible gas shutoff valve shall be provided upstream of each gas pressure regulator. Where two gas pressure regulators are installed in series in a single gas line, a manual valve shall not be required at the second regulator.

7.8.2 Valves Controlling Multiple Systems.

7.8.2.1 Accessibility of Gas Valves. Main gas shutoff valves controlling several gas piping systems shall be readily accessible for operation and installed so as to be protected from physical damage. They shall be marked with a metal tag or other permanent means attached by the installing agency so that the gas piping systems supplied through them can be readily identified.

7.8.2.2 Shutoff Valves for Multiple House Lines. In multiple-tenant buildings supplied through a master meter, through one service regulator where a meter is not provided, or where meters or service regulators are not readily accessible from the appliance or equipment location, an individual shutoff valve for each apartment or tenant line shall be provided at a convenient point of general accessibility. In a common system serving a number of individual buildings, shutoff valves shall be installed at each building.

7.8.2.3 Emergency Shutoff Valves. An exterior shutoff valve to permit turning off the gas supply to each building in an emergency shall be provided. The emergency shutoff valves shall be plainly marked as such and their locations posted as required by the authority having jurisdiction.

7.8.2.4 Shutoff Valve for Laboratories. Each laboratory space containing two or more gas outlets installed on tables, benches, or in hoods in educational, research, commercial, and industrial occupancies shall have a single shutoff valve through which all such gas outlets are supplied. The shutoff valve shall be accessible, located within the laboratory or adjacent to the laboratory's egress door, and identified.

- ▲ 7.9 Prohibited Devices. Devices shall not be placed within the interior of gas piping or fittings where such devices reduce the cross-sectional area or otherwise obstruct the free flow of gas, except where allowance in the piping system design has been made for such devices.

7.10 Systems Containing Gas–Air Mixtures Outside the Flammable Range. Where gas–air mixing machines are employed to produce mixtures above or below the flammable range, they

shall be provided with stops to prevent adjustment of the mixture to within or approaching the flammable range.

7.11 Systems Containing Flammable Gas–Air Mixtures.

7.11.1 Required Components. A central premix system with a flammable mixture in the blower or compressor shall consist of the following components:

- (1) Gas-mixing machine in the form of an automatic gas–air proportioning device combined with a downstream blower or compressor
- (2) Flammable mixture piping, minimum Schedule 40
- (3) Automatic firecheck(s)
- (4) Safety blowout(s) or backfire preventers for systems utilizing flammable mixture lines above 2½ in. (64 mm) nominal pipe size or the equivalent

7.11.2 Optional Components. The following components shall also be permitted to be utilized in any type of central premix system:

- (1) Flowmeter(s)
- (2) Flame arrester(s)

7.11.3 Additional Requirements. Gas-mixing machines shall have nonsparking blowers and shall be constructed so that a flashback does not rupture machine casings.

7.11.4* Special Requirements for Mixing Blowers. A mixing blower system shall be limited to applications with minimum practical lengths of mixture piping, limited to a maximum mixture pressure of 10 in. w.c. (2.5 kPa) and limited to gases containing no more than 10 percent hydrogen. The blower shall be equipped with a gas control valve at its air entrance arranged so that gas is admitted to the airstream, entering the blower in proper proportions for correct combustion by the type of burners employed, the said gas control valve being of either the zero governor or mechanical ratio valve type that controls the gas and air adjustment simultaneously. No valves or other obstructions shall be installed between the blower discharge and the burner or burners.

7.11.5 Installation of Gas-Mixing Machines.

7.11.5.1* Location. The gas-mixing machine shall be located in a well-ventilated area or in a detached building or cutoff room provided with room construction and explosion vents in accordance with sound engineering principles. Such rooms or belowgrade installations shall have adequate positive ventilation.

- ▲ 7.11.5.2 Electrical Requirements. Where gas-mixing machines are installed in well-ventilated areas, the type of electrical equipment shall be in accordance with *NFPA 70* for general service conditions unless other hazards in the area prevail. Where gas-mixing machines are installed in small detached buildings or cutoff rooms, the electrical equipment and wiring shall be installed in accordance with *NFPA 70* for hazardous locations (Articles 500 and 501, Class I, Division 2).

7.11.5.3 Air Intakes. Air intakes for gas-mixing machines using compressors or blowers shall be taken from outdoors whenever practical.

7.11.5.4* Controls. Controls for gas-mixing machines shall include interlocks and a safety shutoff valve of the manual reset type in the gas supply connection to each machine arranged to automatically shut off the gas supply in the event of high or low gas pressure. Except for open burner installations only, the

controls shall be interlocked so that the blower or compressor stops operating following a gas supply failure. Where a system employs pressurized air, means shall be provided to shut off the gas supply in the event of air failure.

7.11.5.5 Installation in Parallel. Centrifugal gas-mixing machines in parallel shall be reviewed by the user and equipment manufacturer before installation, and means or plans for minimizing the effects of downstream pulsation and equipment overload shall be prepared and utilized as needed.

7.11.6 Use of Automatic Firechecks, Safety Blowouts, or Backfire Preventers. Automatic firechecks and safety blowouts or backfire preventers shall be provided in piping systems distributing flammable air-gas mixtures from gas-mixing machines to protect the piping and the machines in the event of flashback, in accordance with the following:

- (1)* Approved automatic firechecks shall be installed upstream as close as practical to the burner inlets following the firecheck manufacturers' instructions.
- (2) A separate manually operated gas valve shall be provided at each automatic firecheck for shutting off the flow of the gas-air mixture through the firecheck after a flashback has occurred. The valve shall be located upstream as close as practical to the inlet of the automatic firecheck. Caution: these valves shall not be reopened after a flashback has occurred until the firecheck has cooled sufficiently to prevent re-ignition of the flammable mixture and has been reset properly.
- (3) A safety blowout or backfiring preventer shall be provided in the mixture line near the outlet of each gas-mixing machine where the size of the piping is larger than 2½ in. (64 mm) NPS, or equivalent, to protect the mixing equipment in the event of an explosion passing through an automatic firecheck. The manufacturers' instructions shall be followed when installing these devices, particularly after a disc has burst. The discharge from the safety blowout or backfire preventer shall be located or shielded so that particles from the ruptured disc cannot be directed toward personnel. Wherever there are interconnected installations of gas-mixing machines with safety blowouts or backfire preventers, provision shall be made to keep the mixture from other machines from reaching any ruptured disc opening. Check valves shall not be used for this purpose.
- (4) Large-capacity premix systems provided with explosion heads (rupture discs) to relieve excessive pressure in pipelines shall be located at and vented to a safe outdoor location. Provisions shall be provided for automatically shutting off the supply of the gas-air mixture in the event of rupture.

7.12 Electrical Bonding and Grounding.

7.12.1 Pipe and Tubing Other than CSST. Each aboveground portion of a gas piping system, other than CSST, that is likely to become energized shall be electrically continuous and bonded to an effective ground-fault current path. Gas piping, other than CSST, shall be considered to be bonded when it is connected to appliances that are connected to the appliance grounding conductor of the circuit supplying that appliance.

7.12.2* CSST. CSST gas piping systems, and gas piping systems containing one or more segments of CSST, shall be electrically continuous and bonded to the electrical service

grounding electrode system or, where provided, lightning protection grounding electrode system.

7.12.2.1 The bonding jumper shall connect to a metallic pipe, pipe fitting, or CSST fitting.

7.12.2.2 The bonding jumper shall not be smaller than 6 AWG copper wire or equivalent.

7.12.2.3* The length of the jumper between the connection to the gas piping system and the grounding electrode system shall not exceed 75 ft (22 m). Any additional grounding electrodes installed to meet this requirement shall be bonded to the electrical service grounding electrode system or, where provided, lightning protection grounding electrode system.

Δ 7.12.2.4 Bonding connections shall be in accordance with *NFPA 70*.

7.12.2.5 Devices used for the bonding connection shall be listed for the application in accordance with ANSI/UL 467, *Grounding and Bonding Equipment*.

N 7.12.3 Arc-Resistant Jacketed CSST. CSST listed with an arc-resistant jacket or coating system in accordance with ANSI LC 1/CSA 6.26, *Fuel Gas Piping Systems Using Corrugated Stainless Steel Tubing*, shall be electrically continuous and bonded to an effective ground fault current path. Where any CSST component of a piping system does not have an arc-resistant jacket or coating system, the bonding requirements of 7.12.2 shall apply. Arc-resistant jacketed CSST shall be considered to be bonded when it is connected to appliances that are connected to the appliance grounding conductor of the circuit supplying that appliance.

7.12.4* Prohibited Use. Gas piping shall not be used as a grounding conductor or electrode.

Δ 7.12.5* Lightning Protection Systems. Where a lightning protection system is installed, the bonding of the gas piping shall be in accordance with *NFPA 780*.

7.13 Electrical Circuits. Electrical circuits shall not utilize gas piping or components as conductors.

Exception: Low-voltage (50 V or less) control circuits, ignition circuits, and electronic flame detection device circuits shall be permitted to make use of piping or components as a part of an electric circuit.

7.14 Electrical Connections.

Δ 7.14.1 All electrical connections between wiring and electrically operated control devices in a piping system shall conform to the requirements of *NFPA 70*.

7.14.2 Any essential safety control depending on electric current as the operating medium shall be of a type that shuts off (fail safe) the flow of gas in the event of current failure.

Chapter 8 Inspection, Testing, and Purging

8.1 Pressure Testing and Inspection.

8.1.1* General.

8.1.1.1 Prior to acceptance and initial operation, all piping installations shall be visually inspected and pressure tested to determine that the materials, design, fabrication, and installation practices comply with the requirements of this code.

8.1.1.2 Inspection shall consist of visual examination, during or after manufacture, fabrication, assembly, or pressure tests.

8.1.1.3 Where repairs or additions are made following the pressure test, the affected piping shall be tested. Minor repairs and additions are not required to be pressure tested, provided that the work is inspected and connections are tested with a noncorrosive leak-detecting fluid or other leak-detecting methods approved by the authority having jurisdiction.

8.1.1.4 Where new branches are installed to new appliance(s), only the newly installed branch(es) shall be required to be pressure tested. Connections between the new piping and the existing piping shall be tested with a noncorrosive leak-detecting fluid or approved leak-detecting methods.

8.1.1.5 A piping system shall be tested as a complete unit or in sections. Under no circumstances shall a valve in a line be used as a bulkhead between gas in one section of the piping system and test medium in an adjacent section, unless a double block and bleed valve system is installed. A valve shall not be subjected to the test pressure unless it can be determined that the valve, including the valve closing mechanism, is designed to safely withstand the pressure.

8.1.1.6 Regulator and valve assemblies fabricated independently of the piping system in which they are to be installed shall be permitted to be tested with inert gas or air at the time of fabrication.

8.1.1.7* Prior to testing, the interior of the pipe shall be cleared of all foreign material.

8.1.2 Test Medium. The test medium shall be air, nitrogen, carbon dioxide, or an inert gas. **Oxygen shall not be used as a test medium.**

8.1.3 Test Preparation.

8.1.3.1 Pipe joints, including welds, shall be left exposed for examination during the test.

Exception: Covered or concealed pipe end joints that have been previously tested in accordance with this code.

8.1.3.2 Expansion joints shall be provided with temporary restraints, if required, for the additional thrust load under test.

8.1.3.3 Appliances and equipment that are not to be included in the test shall be either disconnected from the piping or isolated by blanks, blind flanges, or caps. Flanged joints at which blinds are inserted to blank off other equipment during the test shall not be required to be tested.

8.1.3.4 Where the piping system is connected to appliances or equipment designed for operating pressures of less than the test pressure, such appliances or equipment shall be isolated from the piping system by disconnecting them and capping the outlet(s).

8.1.3.5 Where the piping system is connected to appliances or equipment designed for operating pressures equal to or greater than the test pressure, such appliances or equipment shall be isolated from the piping system by closing the individual appliance or equipment shutoff valve(s).

8.1.3.6 All testing of piping systems shall be performed in a manner that protects the safety of employees and the public during the test.

8.1.4 Test Pressure.

8.1.4.1 Test pressure shall be measured with a manometer or with a pressure measuring device designed and calibrated to read, record, or indicate a pressure loss due to leakage during the pressure test period. The source of pressure shall be isolated before the pressure tests are made. Mechanical gauges used to measure test pressures shall have a range such that the highest end of the scale is not greater than 5 times the test pressure.

8.1.4.2 The test pressure to be used shall be no less than 1½ times the proposed maximum working pressure, but not less than 3 psi (20 kPa), irrespective of design pressure. Where the test pressure exceeds 125 psi (862 kPa), the test pressure shall not exceed a value that produces a hoop stress in the piping greater than 50 percent of the specified minimum yield strength of the pipe.

8.1.4.3* Test duration shall be not less than ½ hour for each 500 ft³ (14 m³) of pipe volume or fraction thereof. When testing a system having a volume less than 10 ft³ (0.28 m³) or a system in a single-family dwelling, the test duration shall be a minimum of 10 minutes. The duration of the test shall not be required to exceed 24 hours.

8.1.5 Detection of Leaks and Defects.

8.1.5.1 The piping system shall withstand the test pressure specified without showing any evidence of leakage or other defects. Any reduction of test pressures as indicated by pressure gauges shall be deemed to indicate the presence of a leak unless such reduction can be readily attributed to some other cause.

8.1.5.2 The leakage shall be located by means of an approved gas detector, a noncorrosive leak detection fluid, or other approved leak detection methods.

8.1.5.3 Where leakage or other defects are located, the affected portion of the piping system shall be repaired or replaced and retested.

8.2 Piping System Leak Check.

8.2.1 Test Gases. Leak checks using fuel gas shall be permitted in piping systems that have been pressure tested in accordance with Section 8.1.

8.2.2 Turning Gas On. During the process of turning gas on into a system of new gas piping, the entire system shall be inspected to determine that there are no open fittings or ends and that all valves at unused outlets are closed and plugged or capped.

8.2.3* Leak Check. Immediately after the gas is turned on into a new system or into a system that has been initially restored after an interruption of service, the piping system shall be checked for leakage. Where leakage is indicated, the gas supply shall be shut off until the necessary repairs have been made.

8.2.4 Placing Appliances and Equipment in Operation. Appliances and equipment shall not be placed in operation until after the piping system has been checked for leakage in accordance with 8.2.3, the piping system is purged in accordance with Section 8.3, and connections to the appliance are checked for leakage.

8.3* Purging Requirements. The purging of piping shall be in accordance with 8.3.1 through 8.3.3.

8.3.1* Piping Systems Required to Be Purged Outdoors. The purging of piping systems shall be in accordance with 8.3.1.1 through 8.3.1.4 where the piping system meets either of the following:

- (1) The design operating gas pressure is greater than 2 psig (14 kPag).
- (2) The piping being purged contains one or more sections of pipe or tubing meeting the size and length criteria of Table 8.3.1.

Table 8.3.1 Size and Length of Piping*

| Nominal Piping Size (in.) | Length of Piping (ft) |
|---------------------------|-----------------------|
| ≥2½ <3 | > 50 |
| ≥3 <4 | > 30 |
| ≥4 <6 | > 15 |
| ≥6 <8 | > 10 |
| ≥8 | Any length |

For SI units, 1 in. = 25.4 mm; 1 ft = 0.305 m.

* CSST EHD size of 62 is equivalent to 2 in. nominal size pipe or tubing.

8.3.1.1 Removal from Service. Where existing gas piping is opened, the section that is opened shall be isolated from the gas supply and the line pressure vented in accordance with 8.3.1.3. Where gas piping meeting the criteria of Table 8.3.1 is removed from service, the residual fuel gas in the piping shall be displaced with an inert gas.

8.3.1.2* Placing in Operation. Where gas piping containing air and meeting the criteria of Table 8.3.1 is placed in operation, the air in the piping shall first be displaced with an inert gas. The inert gas shall then be displaced with fuel gas in accordance with 8.3.1.3.

8.3.1.3 Outdoor Discharge of Purged Gases. The open end of a piping system being pressure vented or purged shall discharge directly to an outdoor location. Purging operations shall comply with all of the following requirements:

- (1) The point of discharge shall be controlled with a shutoff valve.
- (2) The point of discharge shall be located at least 10 ft (3.0 m) from sources of ignition, at least 10 ft (3.0 m) from building openings and at least 25 ft (7.6 m) from mechanical air intake openings.
- (3) During discharge, the open point of discharge shall be continuously attended and monitored with a combustible gas indicator that complies with 8.3.1.4.
- (4) Purging operations introducing fuel gas shall be stopped when 90 percent fuel gas by volume is detected within the pipe.
- (5) Persons not involved in the purging operations shall be evacuated from all areas within 10 ft (3.0 m) of the point of discharge.

8.3.1.4* Combustible Gas Indicator. Combustible gas indicators shall be listed and calibrated in accordance with the manufacturer's instructions. Combustible gas indicators shall numerically display a volume scale from 0 percent to 100 percent in 1 percent or smaller increments.

8.3.2* Piping Systems Allowed to Be Purged Indoors or Outdoors. The purging of piping systems shall be in accordance with the provisions of 8.3.2.1 where the piping system meets both of the following:

- (1) The design operating pressure is 2 psig (14 kPag) or less.
- (2) The piping being purged is constructed entirely from pipe or tubing not meeting the size and length criteria of Table 8.3.1.

8.3.2.1* Purging Procedure. The piping system shall be purged in accordance with one or more of the following:

- (1) The piping shall be purged with fuel gas and shall discharge to the outdoors.
- (2) The piping shall be purged with fuel gas and shall discharge to the indoors or outdoors through an appliance burner not located in a combustion chamber. Such burner shall be provided with a continuous source of ignition.
- (3) The piping shall be purged with fuel gas and shall discharge to the indoors or outdoors through a burner that has a continuous source of ignition and that is designed for such purpose.
- (4) The piping shall be purged with fuel gas that is discharged to the indoors or outdoors, and the point of discharge shall be monitored with a listed combustible gas detector in accordance with 8.3.2.2. Purging shall be stopped when fuel gas is detected.
- (5) The piping shall be purged by the gas supplier in accordance with written procedures.

8.3.2.2 Combustible Gas Detector. Combustible gas detectors shall be listed and calibrated or tested in accordance with the manufacturer's instructions. Combustible gas detectors shall be capable of indicating the presence of fuel gas.

8.3.3 Purging Appliances and Equipment. After the piping system has been placed in operation, appliances and equipment shall be purged before being placed into operation.

Chapter 9 Appliance, Equipment, and Accessory Installation

9.1 General.

9.1.1* Appliances, Equipment, and Accessories to Be Approved. Appliances, equipment, and accessories shall be approved.

9.1.1.1 Approved shall mean "acceptable to the authority having jurisdiction."

9.1.1.2 Listed appliances, equipment, and accessories shall be installed in accordance with Chapter 9 and the manufacturers' installation instructions.

9.1.1.3 Acceptance of unlisted appliances, equipment, and accessories shall be on the basis of a sound engineering evaluation.

9.1.1.4 The unlisted appliance, equipment, or accessory shall be safe and suitable for the proposed service and shall be recommended for the service by the manufacturer.

9.1.2 Added or Converted Appliances. When additional or replacement appliances or equipment is installed or an appliance is converted to gas from another fuel, the location in which the appliances or equipment is to be operated shall be checked to verify the following:

- (1) Air for combustion and ventilation is provided where required, in accordance with the provisions of Section 9.3. Where existing facilities are not adequate, they shall be upgraded to meet Section 9.3 specifications.
- (2) The installation components and appliances meet the clearances to combustible material provisions of 9.2.2. It shall be determined that the installation and operation of the additional or replacement appliances do not render the remaining appliances unsafe for continued operation.
- (3) The venting system is constructed and sized in accordance with the provisions of Chapter 12. Where the existing venting system is not adequate, it shall be upgraded to comply with Chapter 12.

9.1.3 Type of Gas(es). The appliance shall be connected to the fuel gas for which it was designed. No attempt shall be made to convert the appliance from the gas specified on the rating plate for use with a different gas without consulting the installation instructions, the serving gas supplier, or the appliance manufacturer for complete instructions.

9.1.4 Safety Shutoff Devices for Unlisted LP-Gas Appliances Used Indoors. Unlisted appliances for use with undiluted LP-Gases and installed indoors, except attended laboratory equipment, shall be equipped with safety shutoff devices of the complete shutoff type.

△ 9.1.5 Use of Air or Oxygen Under Pressure. Where air or oxygen under pressure is used in connection with the gas supply, effective means such as a back pressure regulator and relief valve shall be provided to prevent air or oxygen from passing back into the gas piping. Where oxygen is used, installation shall be in accordance with NFPA 51.

9.1.6* Protection of Appliances from Fumes or Gases Other than Products of Combustion.

9.1.6.1 Where corrosive or flammable process fumes or gases, such as carbon monoxide, hydrogen sulfide, ammonia, chlorine, and halogenated hydrocarbons, as are present, means for their safe disposal shall be provided.

9.1.6.2 Non-direct-vent appliances installed in beauty shops, barber shops, or other facilities where chemicals that generate corrosive or flammable products such as aerosol sprays are routinely used shall be located in a mechanical room separate or partitioned off from other areas with provisions for combustion and dilution air from outdoors. Direct vent appliances in such facilities shall be in accordance with the appliance manufacturer's installation instructions.

9.1.7 Process Air. In addition to air needed for combustion in commercial or industrial processes, process air shall be provided as required for cooling of appliances, equipment, or material; for controlling dew point, heating, drying, oxidation, dilution, safety exhaust, odor control, and air for compressors; and for comfort and proper working conditions for personnel.

9.1.8 Appliance Support.

9.1.8.1 Appliances and equipment shall be furnished either with load distributing bases or with a sufficient number of supports to prevent damage to either the building structure or the appliance and the equipment.

9.1.8.2 At the locations selected for installation of appliances and equipment, the dynamic and static load carrying capacities of the building structure shall be checked to determine whether they are adequate to carry the additional loads. The appliances and equipment shall be supported and shall be connected to the piping so as not to exert undue stress on the connections.

9.1.9 Flammable Vapors. Appliances shall not be installed in areas where the open use, handling, or dispensing of flammable liquids occurs, unless the design, operation, or installation reduces the potential of ignition of the flammable vapors. Appliances installed in compliance with 9.1.10 through 9.1.12 shall be considered to comply with the intent of this provision.

9.1.10 Installation in Residential Garages.

9.1.10.1 Appliances in residential garages and in adjacent spaces that open to the garage and are not part of the living space of a dwelling unit shall be installed so that all burners and burner ignition devices are located not less than 18 in. (460 mm) above the floor unless listed as flammable vapor ignition resistant.

9.1.10.2 Such appliances shall be located or protected so they are not subject to physical damage by a moving vehicle.

9.1.10.3 Where appliances are installed in a separate, enclosed space having access only from outside of the garage, such appliances shall be permitted to be installed at floor level, providing the required combustion air is taken from the exterior of the garage.

9.1.11 Installation in Commercial Garages.

△ 9.1.11.1 Parking Structures. Appliances installed in enclosed, basement, and underground parking structures shall be installed in accordance with NFPA 88A.

△ 9.1.11.2 Repair Garages. Appliances installed in repair garages shall be installed in accordance with NFPA 30A.

△ 9.1.12 Installation in Aircraft Hangars. Heaters in aircraft hangars shall be installed in accordance with NFPA 409.

9.1.13 Appliance Physical Protection. Where locating appliances close to a passageway traveled by vehicles or machinery is necessary, guardrails or bumper plates shall be installed to protect the equipment from damage.

9.1.14 Venting of Flue Gases. Appliances shall be vented in accordance with the provisions of Chapter 12.

9.1.15 Extra Device or Attachment. No device or attachment shall be installed on any appliance that could in any way impair the combustion of gas.

9.1.16 Adequate Capacity of Piping. When additional appliances are being connected to a gas piping system, the existing piping shall be checked to determine whether it has adequate capacity. Where the capacity is inadequate, the existing system shall be enlarged as necessary, or separate gas piping of adequate capacity shall be run from the point of delivery to the appliance.

9.1.17 Avoiding Strain on Gas Piping. Appliances shall be supported and connected to the piping so as not to exert undue strain on the connections.

9.1.18 Gas Appliance Pressure Regulators. Where the gas supply pressure is higher than that at which the appliance is designed to operate or varies beyond the design pressure limits of the appliance, a gas appliance pressure regulator shall be installed.

9.1.19 Venting of Gas Appliance Pressure Regulators. Venting of gas appliance pressure regulators shall comply with the following requirements:

- (1) Appliance pressure regulators requiring access to the atmosphere for successful operation shall be equipped with vent piping leading outdoors or, if the regulator vent is an integral part of the appliance, into the combustion chamber adjacent to a continuous pilot, unless constructed or equipped with a vent limiting means to limit the escape of gas from the vent opening in the event of diaphragm failure.
- (2) Vent limiting means shall be employed on listed appliance pressure regulators only.
- (3) In the case of vents leading outdoors, means shall be employed to prevent water from entering this piping and also to prevent blockage of vents by insects and foreign matter.
- (4) Under no circumstances shall a regulator be vented to the appliance flue or exhaust system.
- (5) In the case of vents entering the combustion chamber, the vent shall be located so the escaping gas is readily ignited by the pilot and the heat liberated thereby does not adversely affect the normal operation of the safety shutoff system. The terminus of the vent shall be securely held in a fixed position relative to the pilot. For manufactured gas, the need for a flame arrester in the vent piping shall be determined.
- (6) A vent line(s) from an appliance pressure regulator and a bleed line(s) from a diaphragm-type valve shall not be connected to a common manifold terminating in a combustion chamber. Vent lines shall not terminate in positive-pressure-type combustion chambers.

9.1.20 Bleed Lines for Diaphragm-Type Valves. Bleed lines shall comply with the following requirements:

- (1) Diaphragm-type valves shall be equipped to convey bleed gas to the outdoors or into the combustion chamber adjacent to a continuous pilot.
- (2) In the case of bleed lines leading outdoors, means shall be employed to prevent water from entering this piping and also to prevent blockage of vents by insects and foreign matter.
- (3) Bleed lines shall not terminate in the appliance flue or exhaust system.
- (4) In the case of bleed lines entering the combustion chamber, the bleed line shall be located so the bleed gas is readily ignited by the pilot and the heat liberated thereby does not adversely affect the normal operation of the safety shutoff system. The terminus of the bleed line shall be securely held in a fixed position relative to the pilot. For manufactured gas, the need for a flame arrester in the bleed line piping shall be determined.
- (5) A bleed line(s) from a diaphragm-type valve and a vent line(s) from an appliance pressure regulator shall not be connected to a common manifold terminating in a combustion chamber. Bleed lines shall not terminate in positive-pressure-type combustion chambers.

9.1.21 Combination of Appliances and Equipment. Any combination of appliances, equipment, attachments, or devices used together in any manner shall comply with the standards that apply to the individual appliance and equipment.

9.1.22 Installation Instructions. The installing agency shall conform to the appliance and equipment manufacturers' recommendations in completing an installation. The installing agency shall leave the manufacturers' installation, operating, and maintenance instructions in a location on the premises where they are readily available for reference and guidance of the authority having jurisdiction, service personnel, and the owner or operator.

9.1.23 Protection of Outdoor Appliances. Appliances not listed for outdoor installation but installed outdoors shall be provided with protection to the degree that the environment requires. Appliances listed for outdoor installation shall be permitted to be installed without protection in accordance with the manufacturer's installation instructions.

Δ 9.1.24* Existing Appliances. Existing appliance installations shall be inspected to verify compliance with the provisions of Section 9.3 and Chapter 12 where a component of the building envelope is modified as described by one or more of 9.1.24(1) through 9.1.24(6). Where the appliance installation does not comply with Section 9.3 and Chapter 12, the installation shall be altered as necessary to be in compliance with Section 9.3 and Chapter 12.

- (1) The building is modified under a weatherization program.
- (2) A building permit is issued for a building addition or exterior building modification.
- (3) Three or more window assemblies are replaced.
- (4) Three or more storm windows are installed over existing windows.
- (5) One or more exterior door and frame assemblies are replaced.
- (6) A building air barrier is installed or replaced.

9.2 Accessibility and Clearance.

9.2.1 Accessibility for Service. All appliances shall be located with respect to building construction and other equipment so as to permit access to the appliance. Sufficient clearance shall be maintained to permit cleaning of heating surfaces; the replacement of filters, blowers, motors, burners, controls, and vent connections; the lubrication of moving parts where necessary; the adjustment and cleaning of burners and pilots; and the proper functioning of explosion vents, if provided. For attic installation, the passageway and servicing area adjacent to the appliance shall be floored.

Δ 9.2.2 Clearance to Combustible Materials. Appliances and their vent connectors shall be installed with clearances from combustible material so their operation does not create a hazard to persons or property. Minimum clearances between combustible walls and the back and sides of various conventional types of appliances and their vent connectors are specified in Chapters 10 and 12. (*Reference can also be made to NFPA 211.*)

9.2.3 Installation on Carpeting. Appliances shall not be installed on carpeting, unless the appliances are listed for such installation.

9.3* Air for Combustion and Ventilation.

9.3.1 General.

9.3.1.1 Air for combustion, ventilation, and dilution of flue gases for appliances installed in buildings shall be obtained by application of one of the methods covered in 9.3.2 through 9.3.6. Where the requirements of 9.3.2 are not met, outdoor air shall be introduced in accordance with methods covered in 9.3.3 through 9.3.6.

Exception No. 1: This provision shall not apply to direct vent appliances.

Exception No. 2: Type 1 clothes dryers that are provided with make-up air in accordance with 10.4.3.

9.3.1.2 Appliances of other than natural draft design, appliances not designated as Category I vented appliances, and appliances equipped with power burners shall be provided with combustion, ventilation, and dilution air in accordance with the appliance manufacturer's instructions.

9.3.1.3 Appliances shall be located so as not to interfere with proper circulation of combustion, ventilation, and dilution air.

9.3.1.4 Where used, a draft hood or a barometric draft regulator shall be installed in the same room or enclosure as the appliance served so as to prevent any difference in pressure between the hood or regulator and the combustion air supply.

9.3.1.5 Where exhaust fans, clothes dryers, and kitchen ventilation systems interfere with the operation of appliances, make-up air shall be provided.

9.3.2 Indoor Combustion Air. The required volume of indoor air shall be determined in accordance with the method in 9.3.2.1 or 9.3.2.2 except that where the air infiltration rate is known to be less than 0.40 ACH (air change per hour), the method in 9.3.2.2 shall be used. The total required volume shall be the sum of the required volume calculated for all appliances located within the space. Rooms communicating directly with the space in which the appliances are installed through openings not furnished with doors, and through combustion air openings sized and located in accordance with 9.3.2.3, are considered a part of the required volume.

9.3.2.1* Standard Method. The minimum required volume shall be 50 ft³/1000 Btu/hr (4.8 m³/kW).

9.3.2.2* Known Air Infiltration Rate Method. Where the air infiltration rate of a structure is known, the minimum required volume shall be determined as follows:

- (1) For appliances other than fan assisted, calculate using the following equation:

[9.3.2.2(1)]

$$\text{Required Volume}_{\text{other}} \geq \frac{21 \text{ ft}^3}{ACH} \left(\frac{I_{\text{other}}}{1000 \text{ Btu/hr}} \right)$$

- (2) For fan-assisted appliances, calculate using the following equation:

[9.3.2.2(2)]

$$\text{Required Volume}_{\text{fan}} \geq \frac{15 \text{ ft}^3}{ACH} \left(\frac{I_{\text{fan}}}{1000 \text{ Btu/hr}} \right)$$

where:

I_{other} = all appliances other than fan-assisted input (Btu/hr)

I_{fan} = fan-assisted appliance input (Btu/hr)

ACH = air change per hour (percent of volume of space exchanged per hour, expressed as a decimal)

- (3) For purposes of these calculations, an infiltration rate greater than 0.60 ACH shall not be used in the equations in 9.3.2.2(1) and 9.3.2.2(2).

9.3.2.3 Indoor Opening Size and Location. Openings used to connect indoor spaces shall be sized and located in accordance with the following:

- (1)* *Combining spaces on the same story.* Each opening shall have a minimum free area of 1 in.²/1000 Btu/hr (2200 mm²/kW) of the total input rating of all appliances in the space but not less than 100 in.² (0.06 m²). One permanent opening shall commence within 12 in. (300 mm) of the top of the enclosure and one permanent opening shall commence within 12 in. (300 mm) of the bottom of the enclosure. The minimum dimension of air openings shall not be less than 3 in. (80 mm).
- (2) *Combining spaces in different stories.* The volumes of spaces in different stories shall be considered as communicating spaces where such spaces are connected by one or more permanent openings in doors or floors having a total minimum free area of 2 in.²/1000 Btu/hr (4400 mm²/kW) of total input rating of all appliances.

9.3.3 Outdoor Combustion Air. Outdoor combustion air shall be provided through opening(s) to the outdoors in accordance with the methods in 9.3.3.1 or 9.3.3.2. The minimum dimension of air openings shall not be less than 3 in. (80 mm).

9.3.3.1 Two Permanent Openings Method. Two permanent openings, one commencing within 12 in. (300 mm) of the top of the enclosure and one commencing within 12 in. (300 mm) of the bottom of the enclosure, shall be provided. The openings shall communicate directly, or by ducts, with the outdoors or spaces that freely communicate with the outdoors, as follows:

- (1)* Where directly communicating with the outdoors or where communicating to the outdoors through vertical ducts, each opening shall have a minimum free area of 1 in.²/4000 Btu/hr (550 mm²/kW) of total input rating of all appliances in the enclosure.
- (2)* Where communicating with the outdoors through horizontal ducts, each opening shall have a minimum free area of 1 in.²/2000 Btu/hr (1100 mm²/kW) of total input rating of all appliances in the enclosure.

9.3.3.2* One Permanent Opening Method. One permanent opening, commencing within 12 in. (300 mm) of the top of the enclosure, shall be provided. The appliance shall have clearances of at least 1 in. (25 mm) from the sides and back and 6 in. (150 mm) from the front of the appliance. The opening shall

directly communicate with the outdoors or shall communicate through a vertical or horizontal duct to the outdoors or spaces that freely communicate with the outdoors and shall have a minimum free area of the following:

- (1) 1 in.²/3000 Btu/hr (700 mm²/kW) of the total input rating of all appliances located in the enclosure
- (2) Not less than the sum of the areas of all vent connectors in the space

9.3.4 Combination Indoor and Outdoor Combustion Air. The use of a combination of indoor and outdoor combustion air shall be in accordance with the following:

- (1) *Indoor openings.* Where used, openings connecting the interior spaces shall comply with 9.3.2.3.
- (2) *Outdoor opening(s) location.* Outdoor opening(s) shall be located in accordance with 9.3.3.
- (3) *Outdoor opening(s) size.* The outdoor opening(s) size shall be calculated in accordance with the following:
 - (a) The ratio of the interior spaces shall be the available volume of all communicating spaces divided by the required volume.
 - (b) The outdoor size reduction factor shall be 1 minus the ratio of interior spaces.
 - (c) The minimum size of outdoor opening(s) shall be the full size of outdoor opening(s) calculated in accordance with 9.3.3, multiplied by the reduction factor. The minimum dimension of air openings shall not be less than 3 in. (80 mm).

9.3.5 Engineered Installations. Engineered combustion air installations shall provide an adequate supply of combustion, ventilation, and dilution air and shall be approved by the authority having jurisdiction.

9.3.6 Mechanical Combustion Air Supply. Where all combustion air is provided by a mechanical air supply system, the combustion air shall be supplied from outdoors at the minimum rate of 0.35 ft³/min/1000 Btu/hr (0.034 m³/min/kW) for all appliances located within the space.

9.3.6.1 Where exhaust fans are installed, additional air shall be provided to replace the exhausted air.

9.3.6.2 Each of the appliances served shall be interlocked to the mechanical air supply system to prevent main burner operation where the mechanical air supply system is not in operation.

9.3.6.3 Where combustion air is provided by the building's mechanical ventilation system, the system shall provide the specified combustion air rate in addition to the required ventilation air.

9.3.7 Louvers, Grilles, and Screens.

9.3.7.1 Louvers and Grilles. The required size of openings for combustion, ventilation, and dilution air shall be based on the net free area of each opening. Where the free area through a design of louver, grille, or screen is known, it shall be used in calculating the size opening required to provide the free area specified. Where the louver and grille design and free area are not known, it shall be assumed that wood louvers have 25 percent free area, and metal louvers and grilles have 75 percent free area. Nonmotorized louvers and grilles shall be fixed in the open position.

9.3.7.2 Minimum Screen Mesh Size. Screens shall not be smaller than ¼ in. (7 mm) mesh.

9.3.7.3 Motorized Louvers. Motorized louvers shall be interlocked with the appliance so they are proven in the full open position prior to main burner ignition and during main burner operation. Means shall be provided to prevent the main burner from igniting should the louver fail to open during burner startup and to shut down the main burner if the louvers close during burner operation.

9.3.8 Combustion Air Ducts. Combustion air ducts shall comply with 9.3.8.1 through 9.3.8.8.

9.3.8.1 Ducts shall be constructed of galvanized steel or a material having equivalent corrosion resistance, strength, and rigidity.

Exception: Within dwellings units, unobstructed stud and joist spaces shall not be prohibited from conveying combustion air, provided that not more than one fireblock is removed.

9.3.8.2 Ducts shall terminate in an unobstructed space, allowing free movement of combustion air to the appliances.

9.3.8.3 Ducts shall serve a single space.

9.3.8.4 Ducts shall not serve both upper and lower combustion air openings where both such openings are used. The separation between ducts serving upper and lower combustion air openings shall be maintained to the source of combustion air.

9.3.8.5 Ducts shall not be screened where terminating in an attic space.

9.3.8.6 Horizontal upper combustion air ducts shall not slope downward toward the source of combustion air.

9.3.8.7 The remaining space surrounding a chimney liner, gas vent, special gas vent, or plastic piping installed within a masonry, metal, or factory built chimney shall not be used to supply combustion air.

Exception: Direct vent appliances designed for installation in a solid fuel-burning fireplace where installed in accordance with the manufacturer's installation instructions.

9.3.8.8 Combustion air intake openings located on the exterior of the building shall have the lowest side of the combustion air intake openings located at least 12 in. (300 mm) vertically from the adjoining finished ground level.

9.4 Appliances on Roofs.

9.4.1 General.

9.4.1.1 Appliances on roofs shall be designed or enclosed so as to withstand climatic conditions in the area in which they are installed. Where enclosures are provided, each enclosure shall permit easy entry and movement, shall be of reasonable height, and shall have at least a 30 in. (760 mm) clearance between the entire service access panel(s) of the appliance and the wall of the enclosure.

9.4.1.2 Roofs on which appliances are to be installed shall be capable of supporting the additional load or shall be reinforced to support the additional load.

9.4.1.3 All access locks, screws, and bolts shall be of corrosion-resistant material.

9.4.2 Installation of Appliances on Roofs.

9.4.2.1 Appliances shall be installed in accordance with the manufacturers' installation instructions.

9.4.2.2 Appliances shall be installed on a well-drained surface of the roof. At least 6 ft (1.8 m) of clearance shall be available between any part of the appliance and the edge of a roof or similar hazard, or rigidly fixed rails, guards, parapets, or other building structures at least 42 in. (1.1 m) in height shall be provided on the exposed side.

9.4.2.3 All appliances requiring an external source of electrical power for its operation shall be provided with the following:

- (1) A readily accessible electrical disconnecting means within sight of the appliance that completely de-energizes the appliance
- (2) A 120 V ac grounding-type receptacle outlet on the roof adjacent to the appliance on the supply side of the disconnect switch

9.4.2.4 Where water stands on the roof at the appliance or in the passageways to the appliance, or where the roof is of a design having a water seal, a suitable platform, walkway, or both shall be provided above the water line. Such platform(s) or walkway(s) shall be located adjacent to the appliance and control panels so that the appliance can be safely serviced where water stands on the roof.

9.4.3 Access to Appliances on Roofs.

9.4.3.1 Appliances located on roofs or other elevated locations shall be accessible.

9.4.3.2 Buildings of more than 15 ft (4.6 m) in height shall have an inside means of access to the roof, unless other means acceptable to the authority having jurisdiction are used.

9.4.3.3 The inside means of access shall be a permanent or foldaway inside stairway or ladder, terminating in an enclosure, scuttle, or trapdoor. Such scuttles or trapdoors shall be at least 22 in. × 24 in. (560 mm × 610 mm) in size, shall open easily and safely under all conditions, especially snow, and shall be constructed so as to permit access from the roof side unless deliberately locked on the inside. At least 6 ft (1.8 m) of clearance shall be available between the access opening and the edge of the roof or similar hazard, or rigidly fixed rails or guards a minimum of 42 in. (1.1 m) in height shall be provided on the exposed side. Where parapets or other building structures are utilized in lieu of guards or rails, they shall be a minimum of 42 in. (1.1 m) in height.

9.4.3.4 Permanent lighting shall be provided at the roof access. The switch for such lighting shall be located inside the building near the access means leading to the roof.

9.5 Appliances in Attics.

9.5.1 Attic Access. An attic in which an appliance is installed shall be accessible through an opening and passageway at least as large as the largest component of the appliance and not less than 22 in. × 30 in. (560 mm × 760 mm).

9.5.1.1 Where the height of the passageway is less than 6 ft (1.8 m), the distance from the passageway access to the appliance shall not exceed 20 ft (6.1 m) measured along the centerline of the passageway.

9.5.1.2 The passageway shall be unobstructed and shall have solid flooring not less than 24 in. (610 mm) wide from the entrance opening to the appliance.

9.5.2 Work Platform. A level working platform not less than 30 in. × 30 in. (760 mm × 760 mm) shall be provided in front of the service side of the appliance.

9.5.3 Lighting and Convenience Outlet. A permanent 120 V receptacle outlet and a lighting fixture shall be installed near the appliance. The switch controlling the lighting fixture shall be located at the entrance to the passageway.

9.6 Appliance and Equipment Connections to Building Piping.

9.6.1 Connecting Appliances and Equipment. Appliances and equipment shall be connected to the building piping in compliance with 9.6.5 through 9.6.7 by one of the following:

- (1) Rigid metallic pipe and fittings.
- (2) Semirigid metallic tubing and metallic fittings. Aluminum alloy tubing shall not be used in exterior locations.
- (3) A listed connector in compliance with ANSI Z21.24/CSA 6.10, *Connectors for Gas Appliances*. The connector shall be used in accordance with the manufacturer's installation instructions and shall be in the same room as the appliance. Only one connector shall be used per appliance.
- (4) A listed connector in compliance with ANSI Z21.75/CSA 6.27, *Connectors for Outdoor Gas Appliances and Manufactured Homes*. Only one connector shall be used per appliance.
- (5) CSST where installed in accordance with the manufacturer's installation instructions. CSST shall connect only to appliances that are fixed in place.
- (6) Listed nonmetallic gas hose connectors in accordance with 9.6.2.
- (7) Unlisted gas hose connectors for use in laboratories and educational facilities in accordance with 9.6.3.

9.6.1.1 Protection of Connectors. Connectors and tubing addressed in 9.6.1(2), 9.6.1(3), 9.6.1(4), 9.6.1(5), and 9.6.1(6) shall be installed to be protected against physical and thermal damage. Aluminum alloy tubing and connectors shall be coated to protect against external corrosion where they are in contact with masonry, plaster, or insulation or are subject to repeated wettings by such liquids as detergents, sewage, or water other than rainwater.

9.6.1.2 Materials addressed in 9.6.1(2), 9.6.1(3), 9.6.1(4), 9.6.1(5), and 9.6.1(6) shall not be installed through an opening in an appliance housing, cabinet, or casing, unless the tubing or connector is protected against damage.

9.6.1.3 Commercial Cooking Appliance Connectors. Connectors used with commercial cooking appliances that are moved for cleaning and sanitation purposes shall be installed in accordance with the connector manufacturer's installation instructions. Such connectors shall be listed in accordance with ANSI Z21.69/CSA 6.16, *Connectors for Movable Gas Appliances*.

9.6.1.4 Restraint. Movement of appliances with casters shall be limited by a restraining device installed in accordance with the connector and appliance manufacturer's installation instructions.

9.6.1.5* Suspended Low-Intensity Infrared Tube Heaters. Suspended low-intensity infrared tube heaters shall be connected to the building piping system with a connector listed for

the application in accordance with ANSI Z21.24/CSA 6.10, *Connectors for Gas Appliances*.

(A) The connector shall be installed in accordance with the tube heater installation instructions and shall be in the same room as the appliance.

(B) Only one connector shall be used per appliance.

9.6.2 Use of Nonmetallic Gas Hose Connectors. Listed gas hose connectors shall be used in accordance with the manufacturer's installation instructions and as follows:

- (1) *Indoor.* Indoor gas hose connectors shall be used only to connect laboratory, shop, and ironing appliances requiring mobility during operation and installed in accordance with the following:
 - (a) An appliance shutoff valve shall be installed where the connector is attached to the building piping.
 - (b) The connector shall be of minimum length and shall not exceed 6 ft (1.8 m).
 - (c) The connector shall not be concealed and shall not extend from one room to another or pass through wall partitions, ceilings, or floors.
- (2) *Outdoor.* Where outdoor gas hose connectors are used to connect portable outdoor appliances, the connector shall be listed in accordance with ANSI Z21.54, *Gas Hose Connectors for Portable Outdoor Gas-Fired Appliances* and installed in accordance with the following:
 - (a) An appliance shutoff valve, a listed quick-disconnect device, or a listed gas convenience outlet shall be installed where the connector is attached to the supply piping and in such a manner so as to prevent the accumulation of water or foreign matter.
 - (b) This connection shall be made only in the outdoor area where the appliance is to be used.

9.6.3* Injection (Bunsen) burners used in laboratories and educational facilities shall be permitted to be connected to the gas supply by an unlisted hose.

9.6.4 Connection of Portable and Mobile Industrial Appliances.

9.6.4.1 Where portable industrial appliances or appliances requiring mobility or subject to vibration are connected to the building gas piping system by the use of a flexible hose, the hose shall be suitable and safe for the conditions under which it can be used.

9.6.4.2 Where industrial appliances requiring mobility are connected to the rigid piping by the use of swivel joints or couplings, the swivel joints or couplings shall be suitable for the service required and only the minimum number required shall be installed.

9.6.4.3 Where industrial appliances subject to vibration are connected to the building piping system by the use of all metal flexible connectors, the connectors shall be suitable for the service required.

9.6.4.4 Where flexible connections are used, they shall be of the minimum practical length and shall not extend from one room to another or pass through any walls, partitions, ceilings, or floors. Flexible connections shall not be used in any concealed location. They shall be protected against physical or thermal damage and shall be provided with gas shutoff valves

in readily accessible locations in rigid piping upstream from the flexible connections.

9.6.5 Appliance Shutoff Valves and Connections. Each appliance connected to a piping system shall have an accessible, approved manual shutoff valve with a nondisplaceable valve member, or a listed gas convenience outlet. Appliance shutoff valves and convenience outlets shall serve a single appliance only and shall be installed in accordance with 9.6.5.1.

9.6.5.1 The shutoff valve shall be located within 6 ft (1.8 m) of the appliance it serves except as permitted in 9.6.5.2 or 9.6.5.3.

(A) Where a connector is used, the valve shall be installed upstream of the connector. A union or flanged connection shall be provided downstream from the valve to permit removal of appliance controls.

(B) Shutoff valves serving decorative appliances in a fireplace shall not be located within the fireplace firebox except where the valve is listed for such use.

9.6.5.2 Shutoff valves serving appliances installed in vented fireplaces and ventless firebox enclosures shall not be required to be located within 6 ft (1.8 m) of the appliance where such valves are readily accessible and permanently identified. The piping from the shutoff valve to within 6 ft (1.8 m) of the appliance shall be designed, sized, installed, and tested in accordance with Chapters 5, 6, 7, and 8.

9.6.5.3 Where installed at a manifold, the appliance shutoff valve shall be located within 50 ft (15 m) of the appliance served and shall be readily accessible and permanently identified. The piping from the manifold to within 6 ft (1.8 m) of the appliance shall be designed, sized, installed, and tested in accordance with Chapters 5, 6, 7, and 8.

9.6.6 Quick-Disconnect Devices.

9.6.6.1 Quick-disconnect devices used to connect appliances to the building piping shall be listed to ANSI Z21.41/CSA 6.9, *Quick-Disconnect Devices for Use with Gas Fuel Appliances*.

9.6.6.2 Where installed indoors, an approved manual shutoff valve with a nondisplaceable valve member shall be installed upstream of the quick-disconnect device.

9.6.7 Gas Convenience Outlets. Gas convenience outlets shall be listed in accordance with ANSI Z21.90/CSA 6.24, *Gas Convenience Outlets and Optional Enclosures*, and installed in accordance with the manufacturer's installation instructions.

9.6.8 Sediment Trap. Where a sediment trap is not incorporated as a part of the appliance, a sediment trap shall be installed downstream of the appliance shutoff valve as close to the inlet of the appliance as practical at the time of appliance installation. The sediment trap shall be either a tee fitting with a capped nipple in the bottom outlet, as illustrated in Figure 9.6.8, or another device recognized as an effective sediment trap. Illuminating appliances, gas ranges, clothes dryers, decorative appliances for installation in vented fireplaces, gas fireplaces, and outdoor cooking appliances shall not be required to be so equipped.

9.6.9 Installation of Piping. Piping shall be installed in a manner not to interfere with inspection, maintenance, or servicing of the appliances.

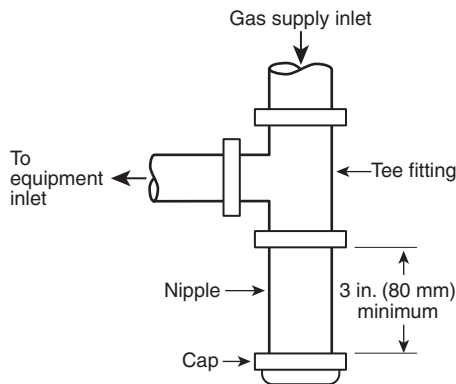

FIGURE 9.6.8 Method of Installing a Tee Fitting Sediment Trap.

9.7 Electrical.

9.7.1 Electrical Connections. Electrical connections between appliances and the building wiring, including the grounding of the appliances, shall conform to *NFPA 70*.

9.7.2 Electrical Ignition and Control Devices. Electrical ignition, burner control, and electrical vent damper devices shall not permit unsafe operation of the appliance in the event of electrical power interruption or when the power is restored.

9.7.3 Electrical Circuit. The electrical circuit employed for operating the automatic main gas control valve, automatic pilot, room temperature thermostat, limit control, or other electrical devices used with the appliances shall be in accordance with the wiring diagrams certified or approved by the original appliance manufacturer.

9.8 Room Temperature Thermostats.

9.8.1 Locations. Room temperature thermostats shall be installed in accordance with the manufacturer's instructions.

9.8.2 Drafts. Any hole in the plaster or panel through which the wires pass from the thermostat to the appliance being controlled shall be sealed so as to prevent drafts from affecting the thermostat.

Chapter 10 Installation of Specific Appliances

10.1 General.

10.1.1* Application. Listed appliances shall be installed in accordance with the manufacturers' installation instructions or, as elsewhere specified in this chapter, as applicable to the appliance. Unlisted appliances shall be installed as specified in this chapter as applicable to the appliances.

10.1.2* Installation in a Bedroom or Bathroom. Appliances shall not be installed so their combustion, ventilation, and dilution air are obtained only from a bedroom or bathroom unless the bedroom or bathroom has the required volume in accordance with 9.3.2.

10.2 Air-Conditioning Appliances (Gas-Fired Air Conditioners and Heat Pumps).

10.2.1 Independent Gas Piping. Gas piping serving heating appliances shall be permitted to also serve cooling appliances

where heating and cooling appliances cannot be operated simultaneously.

10.2.2 Connection of Gas Engine-Powered Air Conditioners. To protect against the effects of normal vibration in service, gas engines shall not be rigidly connected to the gas supply piping.

10.2.3 Clearances for Indoor Installation. The installation of air-conditioning appliances shall comply with the following requirements:

- (1) Listed air-conditioning appliances shall be installed with clearances in accordance with the manufacturer's instructions.
- (2) Unlisted air-conditioning appliances shall be installed with clearances from combustible material of not less than 18 in. (460 mm) above the appliance and at the sides, front, and rear and in accordance with the manufacturer's installation instructions.
- (3) Listed and unlisted air-conditioning appliances shall be permitted to be installed with reduced clearances to combustible material or appliance is protected as described in Table 10.2.3 and such reduction is allowed by the manufacturer's installation instructions.
- (4) Where the furnace plenum is adjacent to plaster on metal lath or noncombustible material attached to combustible material, the clearance shall be measured to the surface of the plaster or other noncombustible finish where the clearance specified is 2 in. (50 mm) or less.
- (5) Listed air-conditioning appliances shall have the clearance from supply ducts within 3 ft (0.9 m) of the furnace plenum be not less than that specified from the furnace plenum. No clearance is necessary beyond this distance.

10.2.4 Assembly and Installation. Air-conditioning appliances shall be installed in accordance with the manufacturer's instructions. Unless the appliance is listed for installation on a combustible surface such as a floor or roof, or unless the surface is protected in an approved manner, it shall be installed on a surface of noncombustible construction with noncombustible material and surface finish and with no combustible material against the underside thereof.

10.2.5 Furnace Plenums and Air Ducts. A furnace plenum supplied as a part of the air-conditioning appliance shall be installed in accordance with the manufacturer's instructions. Where a furnace plenum is not supplied with the appliance, any fabrication and installation instructions provided by the manufacturer shall be followed. The method of connecting supply and return ducts shall facilitate proper circulation of air. Where the air conditioner is installed within an enclosure, the installation shall comply with 10.3.7.4.

10.2.6* Refrigeration Coils. The installation of refrigeration coils shall be in accordance with 10.3.8 and 10.3.9.

10.2.7 Switches in Electrical Supply Line. Means for interrupting the electrical supply to the air-conditioning appliance and to its associated cooling tower (if supplied and installed in a location remote from the air conditioner) shall be provided within sight of and not over 50 ft (15 m) from the air conditioner and the cooling tower.

△ Table 10.2.3 Reduction of Clearances with Specified Forms of Protection

| Type of protection applied to and covering all surfaces of combustible material within the distance specified as the required clearance with no protection | Where the required clearance with no protection from appliance, vent connector, or single-wall metal pipe is: | | | | | | | | | |
|------------------------------------------------------------------------------------------------------------------------------------------------------------|-----------------------------------------------------------------------------------------------------------------------------------------------------------------|----------------------------|-------------------|----------------------------|-------------------|----------------------------|-------------------|----------------------------|-------------------|----------------------------|
| | 36 in. | | 18 in. | | 12 in. | | 9 in. | | 6 in. | |
| | Allowable Clearances with Specified Protection (in.) | | | | | | | | | |
| | Use Col. 1 for clearances above appliance or horizontal connector. Use Col. 2 for clearances from appliance, vertical connector, and single-wall metal pipe. | | | | | | | | | |
| | Above (Col. 1) | Sides and Rear (Col. 2) | Above (Col. 1) | Sides and Rear (Col. 2) | Above (Col. 1) | Sides and Rear (Col. 2) | Above (Col. 1) | Sides and Rear (Col. 2) | Above (Col. 1) | Sides and Rear (Col. 2) |
| (1) 3½ in. thick masonry wall without ventilated air space | — | 24 | — | 12 | — | 9 | — | 6 | — | 5 |
| (2) ½ in. insulation board over 1 in. glass fiber or mineral wool batts | 24 | 18 | 12 | 9 | 9 | 6 | 6 | 5 | 4 | 3 |
| (3) 0.024 in. (nominal 24 gauge) sheet metal over 1 in. glass fiber or mineral wool batts reinforced with wire on rear face with ventilated air space | 18 | 12 | 9 | 6 | 6 | 4 | 5 | 3 | 3 | 3 |
| (4) 3½ in. thick masonry wall with ventilated air space | — | 12 | — | 6 | — | 6 | — | 6 | — | 6 |
| (5) 0.024 in. (nominal 24 gauge) sheet metal with ventilated air space | 18 | 12 | 9 | 6 | 6 | 4 | 5 | 3 | 3 | 2 |
| (6) ½ in. thick insulation board with ventilated air space | 18 | 12 | 9 | 6 | 6 | 4 | 5 | 3 | 3 | 3 |
| (7) 0.024 in. (nominal 24 gauge) sheet metal with ventilated air space over 0.024 in. (nominal 24 gauge) sheet metal with ventilated air space | 18 | 12 | 9 | 6 | 6 | 4 | 5 | 3 | 3 | 3 |
| (8) 1 in. glass fiber or mineral wool batts sandwiched between two sheets 0.024 in. (nominal 24 gauge) sheet metal with ventilated air space | 18 | 12 | 9 | 6 | 6 | 4 | 5 | 3 | 3 | 3 |

For SI units, 1 in. = 25.4 mm.

- Notes:
- (1) Reduction of clearances from combustible materials shall not interfere with combustion air, draft hood clearance and relief, and accessibility of servicing.
 - (2) All clearances shall be measured from the outer surface of the combustible material to the nearest point on the surface of the appliance, disregarding any intervening protection applied to the combustible material.
 - (3) Spacers and ties shall be of noncombustible material. No spacer or tie shall be used directly opposite the appliance or connector.
 - (4) Where all clearance reduction systems use a ventilated air space, adequate provision for air circulation shall be provided as described.
 - (5) At least 1 in. (25 mm) shall be between clearance reduction systems and combustible walls and ceilings for reduction systems using a ventilated air space.
 - (6) Where a wall protector is mounted on a single flat wall away from corners, it shall have a minimum 1 in. (25 mm) air gap. To provide adequate air circulation, the bottom and top edges, or only the side and top edges, or all edges shall be left open.
 - (7) Mineral wool batts (blanket or board) shall have a minimum density of 8 lb/ft³ (128 kg/m³) and a minimum melting point of 1500°F (816°C).
 - (8) Insulation material used as part of a clearance reduction system shall have a thermal conductivity of 1.0 Btu in./ft²/hr-°F (0.144 W/m-K) or less.
 - (9) At least 1 in. (25 mm) shall be between the appliance and the protector. In no case shall the clearance between the appliance and the combustible surface be reduced below that allowed in Table 10.2.3.
 - (10) All clearances and thicknesses are minimum; larger clearances and thicknesses are acceptable.
 - (11) Listed single-wall connectors shall be installed in accordance with the manufacturers' installation instructions.

10.3 Central Heating Boilers and Furnaces.

10.3.1 Location. Central heating furnace and low-pressure boiler installations in bedrooms or bathrooms shall comply with one of the following:

- (1) Central heating furnaces and low-pressure boilers shall be installed in a closet equipped with a weather-stripped door with no openings, and with a self-closing device. All combustion air shall be obtained from the outdoors in accordance with 9.3.3.
- (2) Central heating furnaces and low-pressure boilers shall be of the direct vent type.

10.3.2 Clearances.

10.3.2.1 Listed central heating furnaces and low-pressure boilers shall be installed with clearances in accordance with the manufacturer's instructions.

10.3.2.2 Unlisted central heating furnaces and low-pressure boilers shall be installed with clearances from combustible material not less than those specified in Table 10.3.2.2.

10.3.2.3 Listed and unlisted central heating furnaces and low-pressure boilers shall be permitted to be installed with reduced clearances to combustible material, provided that the combustible material or appliance is protected as described in Table 10.2.3 and Figure 10.3.2.3(a) through Figure 10.3.2.3(c), and such reduction is allowed by the manufacturer's installation instructions.

10.3.2.4 Front clearance shall be sufficient for servicing the burner and the furnace or boiler.

10.3.2.5 Where the furnace plenum is adjacent to plaster on metal lath or noncombustible material attached to combustible material, the clearance shall be measured to the surface of the plaster or other noncombustible finish where the clearance specified is 2 in. (50 mm) or less.

10.3.2.6 The clearances to these appliances shall not interfere with combustion air, draft hood clearance and relief, and accessibility for servicing.

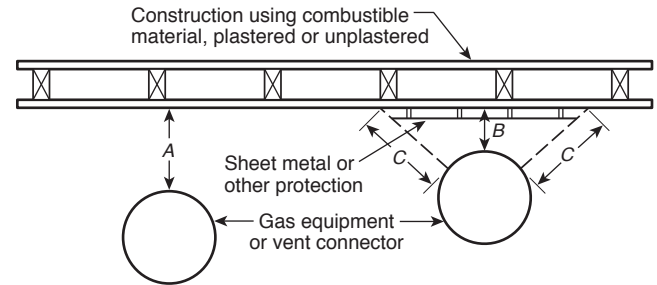

Notes:

- (1) A equals the clearance with no protection specified in Tables 10.3.2.2 and 12.8.4.4 and in the sections applying to various types of equipment.
- (2) B equals the reduced clearance permitted in accordance with Table 10.2.3.
- (3) The protection applied to the construction using combustible material shall extend far enough in each direction to make C equal to A.

FIGURE 10.3.2.3(a) Extent of Protection Necessary to Reduce Clearances from Gas Appliance or Vent Connectors.

10.3.2.7 Supply air ducts connecting to listed central heating furnaces shall have the same minimum clearance to combustibles as required for the furnace supply plenum for a distance of not less than 3 ft (0.9 m) from the supply plenum. Clearance shall not be required beyond the 3 ft (0.9 m) distance.

10.3.2.8 Supply air ducts connecting to unlisted central heating furnaces equipped with temperature limit controls with a maximum setting of 250°F (121°C) shall have a minimum clearance to combustibles of 6 in. (150 mm) for a distance of not less than 6 ft (1.8 m) from the furnace supply plenum. Clearance shall not be required beyond the 6 ft (1.8 m) distance.

10.3.2.9 Central heating furnaces other than those listed in 10.3.2.7 or 10.3.2.8 shall have clearances from the supply ducts of not less than 18 in. (460 mm) from the furnace plenum for the first 3 ft (0.9 m), then 6 in. (150 mm) for the next 3 ft (0.9 m), and 1 in. (25 mm) beyond 6 ft (1.8 m).

Table 10.3.2.2 Clearances to Combustible Material for Unlisted Furnaces and Boilers

| Appliance | Minimum Clearance (in.) | | | | | |
|--------------------------------------------------------------------------------------------------------------------------------------------------------|-----------------------------------|---------------|-----------------------|-------|-------------------------------------------|----------------------------|
| | Above and Sides of Furnace Plenum | Top of Boiler | Jacket Sides and Rear | Front | Draft Hood and Barometric Draft Regulator | Single-Wall Vent Connector |
| I Automatically fired, forced air or gravity system, equipped with temperature limit control that cannot be set higher than 250°F (121°C) | 6 | — | 6 | 18 | 6 | 18 |
| II Automatically fired heating boilers — steam boilers operating at not over 15 psi (103 kPa) and hot water boilers operating at 250°F (121°C) or less | 6 | 6 | 6 | 18 | 18 | 18 |
| III Central heating boilers and furnaces, other than in I or II | 18 | 18 | 18 | 18 | 18 | 18 |

For SI units, 1 in. = 25.4 mm.

Note: See 10.3.1 for additional requirements for central heating boilers and furnaces.

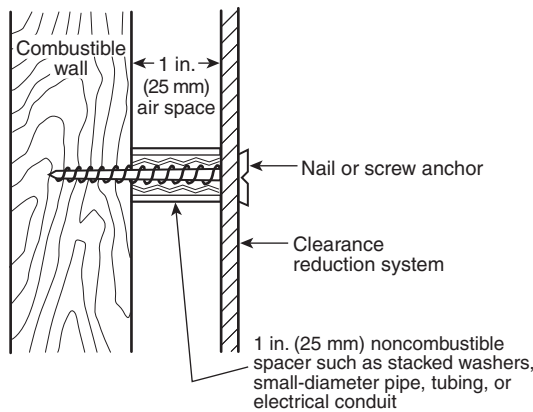
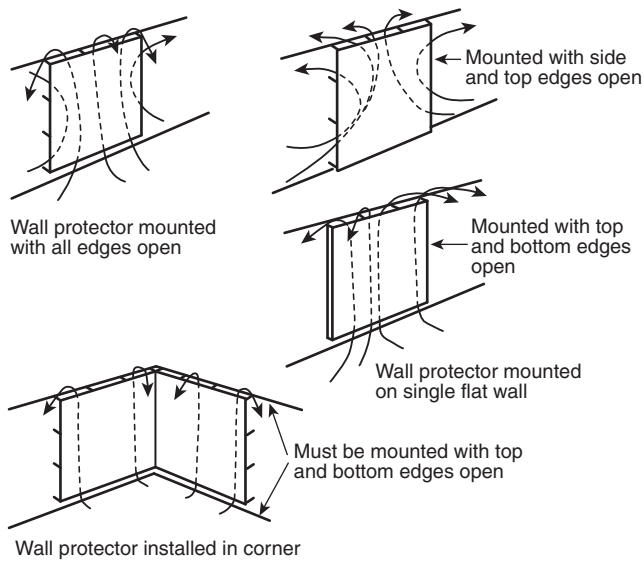

Notes:

- (1) Masonry walls can be attached to combustible walls using wall ties.
- (2) Spacers should not be used directly behind appliance or connector.

FIGURE 10.3.2.3(b) Wall Protector Clearance Reduction System.

10.3.3 Assembly and Installation. A central heating boiler or furnace shall be installed in accordance with the manufacturer's instructions in one of the following manners:

- (1) On a floor of noncombustible construction with noncombustible flooring and surface finish and with no combustible material against the underside thereof
- (2) On fire-resistive slabs or arches having no combustible material against the underside thereof

Exception No. 1: Appliances listed for installation on a combustible floor.

Exception No. 2: Installation on a floor protected in an approved manner.

10.3.4 Temperature or Pressure Limiting Devices. Steam and hot water boilers, respectively, shall be provided with approved automatic limiting devices for shutting down the burner(s) to prevent boiler steam pressure or boiler water temperature from

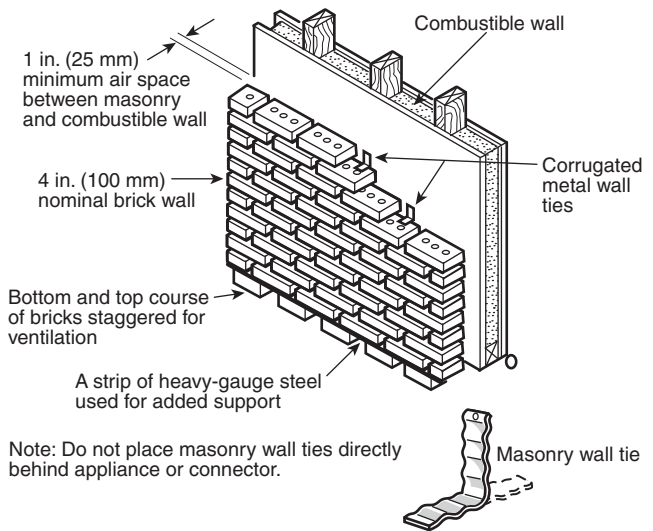

FIGURE 10.3.2.3(c) Masonry Clearance Reduction System.

exceeding the maximum allowable working pressure or temperature. Safety limit controls shall not be used as operating controls.

10.3.5 Low-Water Cutoff. All water boilers and steam boilers shall be provided with an automatic means to shut off the fuel supply to the burner(s) if the boiler water level drops below the lowest safe water line. In lieu of the low-water cutoff, water tube or coil-type boilers that require forced circulation to prevent overheating and failure shall have an approved flow sensing device arranged to shut down the boiler when the flow rate is inadequate to protect the boiler against overheating.

10.3.6* Steam Safety and Pressure Relief Valves. Steam and hot water boilers shall be equipped, respectively, with listed or approved steam safety or pressure relief valves of appropriate discharge capacity and conforming with ASME requirements. A shutoff valve shall not be placed between the relief valve and the boiler or on discharge pipes between such valves and the atmosphere.

10.3.6.1 Relief valves shall be piped to discharge near the floor.

10.3.6.2 The entire discharged piping shall be at least the same size as the relief valve discharge piping.

10.3.6.3 Discharge piping shall not contain threaded end connection at its termination point.

10.3.7 Furnace Plenums and Air Ducts.

▲ 10.3.7.1 Furnace plenums and air ducts shall be installed in accordance with NFPA 90A or NFPA 90B.

10.3.7.2 A furnace plenum supplied as a part of a furnace shall be installed in accordance with the manufacturer's instructions.

10.3.7.3* Where a furnace plenum is not supplied with the furnace, any fabrication and installation instructions provided by the manufacturer shall be followed. The method of connecting supply and return ducts shall facilitate proper circulation of air.

10.3.7.4 Where a furnace is installed so supply ducts carry air circulated by the furnace to areas outside the space containing the furnace, the return air shall also be handled by a duct(s) sealed to the furnace casing and terminating outside the space containing the furnace.

10.3.8 Refrigeration Coils. The installation of refrigeration coils shall comply with the following requirements:

- (1) A refrigeration coil shall not be installed in conjunction with a forced air furnace where circulation of cooled air is provided by the furnace blower, unless the blower has sufficient capacity to overcome the external static pressure resistance imposed by the duct system and refrigeration coil at the air flow rate for heating or cooling, whichever is greater.
- (2) Furnaces shall not be located upstream from refrigeration coils, unless the refrigeration coil is designed or equipped so as not to develop excessive temperature or pressure.
- (3) Refrigeration coils shall be installed in parallel with or on the downstream side of central furnaces to avoid condensation in the heating element, unless the furnace has been specifically listed for downstream installation. With a parallel flow arrangement, the dampers or other means used to control flow of air shall be sufficiently tight to prevent any circulation of cooled air through the furnace.
- (4) Means shall be provided for disposal of condensate and to prevent dripping of condensate on the heating element.

10.3.9 Cooling Units Used with Heating Boilers.

10.3.9.1 Boilers, where used in conjunction with refrigeration systems, shall be installed so that the chilled medium is piped in parallel with the heating boiler with appropriate valves to prevent the chilled medium from entering the heating boiler.

10.3.9.2 Where hot water heating boilers are connected to heating coils located in air-handling units where they can be exposed to refrigerated air circulation, such boiler piping systems shall be equipped with flow control valves or other automatic means to prevent gravity circulation of the boiler water during the cooling cycle.

10.4 Clothes Dryers.

10.4.1 Clearance. The installation of clothes dryers shall comply with the following requirements:

- (1) Listed Type 1 clothes dryers shall be installed with a minimum clearance of 6 in. (150 mm) from adjacent combustible material. Clothes dryers listed for installation at reduced clearances shall be installed in accordance with the manufacturer's installation instructions. Type 1 clothes dryers installed in closets shall be specifically listed for such installation.
- (2) Listed Type 2 clothes dryers shall be installed with clearances of not less than shown on the marking plate and in the manufacturer's instructions. Type 2 clothes dryers designed and marked "For use only in noncombustible locations" shall not be installed elsewhere.
- (3) Unlisted clothes dryers shall be installed with clearances to combustible material of not less than 18 in. (460 mm). Combustible floors under unlisted clothes dryers shall be protected in an approved manner.

10.4.2 Exhausting to the Outdoors. Type 1 and Type 2 clothes dryers shall be exhausted to the outdoors.

10.4.3 Provisions for Make-Up Air.

10.4.3.1 Make-up air shall be provided for Type 1 clothes dryers in accordance with the manufacturers' installation instructions.

10.4.3.2 Provision for make-up air shall be provided for Type 2 clothes dryers, with a minimum free area of 1 in.²/1000 Btu/hr (2200 mm²/kW) total input rating of the dryer(s) installed.

10.4.4 Exhaust Ducts for Type 1 Clothes Dryers.

10.4.4.1 A clothes dryer exhaust duct shall not be connected into any vent connector, gas vent, chimney, crawl space, attic, or other similar concealed space.

10.4.4.2 Ducts for exhausting clothes dryers shall not be assembled with screws or other fastening means that extend into the duct and that would catch lint and reduce the efficiency of the exhaust system.

10.4.4.3 Exhaust ducts shall be constructed of rigid metallic material. Transition ducts used to connect the dryer to the exhaust duct shall be listed and labeled in accordance with ANSI/UL 2158A, *Clothes Dryer Transition Ducts*, and installed in accordance with the clothes dryer manufacturer's installation instructions.

10.4.5 Exhaust Ducts for Type 2 Clothes Dryers.

10.4.5.1 Exhaust ducts for Type 2 clothes dryers shall comply with 10.4.4.

10.4.5.2 Exhaust ducts for Type 2 clothes dryers shall be constructed of sheet metal or other noncombustible material. Such ducts shall be equivalent in strength and corrosion resistance to ducts made of galvanized sheet steel not less than 0.0195 in. (0.5 mm) thick.

10.4.5.3 Type 2 clothes dryers shall be equipped or installed with lint-controlling means.

10.4.5.4 Exhaust ducts for unlisted Type 2 clothes dryers shall be installed with a minimum clearance of 6 in. (150 mm) from adjacent combustible material. Where exhaust ducts for Type 2 clothes dryers are installed with reduced clearances, the adjacent combustible material shall be protected in accordance with Table 10.2.3.

10.4.5.5 Where ducts pass through walls, floors, or partitions, the space around the duct shall be sealed with noncombustible material.

10.4.5.6 Multiple installations of Type 2 clothes dryers shall be made in a manner to prevent adverse operation due to back pressures that might be created in the exhaust systems.

10.4.6 Multiple-Family or Public Use. All clothes dryers installed for multiple-family or public use shall be equipped with approved safety shutoff devices and shall be installed as specified for a Type 2 clothes dryer under 10.4.5.

10.5 Conversion Burners. Installation of conversion burners shall conform to ANSI Z21.8, *Installation of Domestic Gas Conversion Burners*.

10.6 Decorative Appliances for Installation in Vented Fireplaces.

10.6.1* Prohibited Installations. Decorative appliances for installation in vented fireplaces shall not be installed in bath-

Table 10.6.2.3 Free Opening Area of Chimney Damper for Venting Flue Gases from Unlisted Decorative Appliances for Installation in Vented Fireplaces

| Chimney Height (ft) | Minimum Permanent Free Opening (in. ²)* | | | | | | |
|---------------------|-----------------------------------------------------|--------|--------|--------|--------|---------|---------|
| | 8 | 13 | 20 | 29 | 39 | 51 | 64 |
| | Appliance Input Rating (Btu/hr) | | | | | | |
| 6 | 7,800 | 14,000 | 23,200 | 34,000 | 46,400 | 62,400 | 80,000 |
| 8 | 8,400 | 15,200 | 25,200 | 37,000 | 50,400 | 68,000 | 86,000 |
| 10 | 9,000 | 16,800 | 27,600 | 40,400 | 55,800 | 74,400 | 96,400 |
| 15 | 9,800 | 18,200 | 30,200 | 44,600 | 62,400 | 84,000 | 108,800 |
| 20 | 10,600 | 20,200 | 32,600 | 50,400 | 68,400 | 94,000 | 122,200 |
| 30 | 11,200 | 21,600 | 36,600 | 55,200 | 76,800 | 105,800 | 138,600 |

For SI units, 1 ft = 0.305 m, 1 in.² = 645 mm², 1000 Btu/hr = 0.293 kW.

* The first six minimum permanent free openings (8 in.² to 51 in.²) correspond approximately to the cross-sectional areas of chimneys having diameters of 3 in. through 8 in., respectively. The 64 in.² opening corresponds to the cross-sectional area of standard 8 in. × 8 in. chimney tile.

rooms or bedrooms unless the appliance is listed and the bedroom or bathroom has the required volume in accordance with 9.3.2.

10.6.2 Installation. A decorative appliance for installation in a vented fireplace shall be installed only in a vented fireplace having a working chimney flue and constructed of noncombustible materials. These appliances shall not be thermostatically controlled.

10.6.2.1 A listed decorative appliance for installation in a vented fireplace shall be installed in accordance with the manufacturer's installation instructions.

10.6.2.2 A decorative appliance for installation in a vented fireplace, where installed in a manufactured home, shall be listed for installation in manufactured homes.

10.6.2.3 An unlisted decorative appliance for installation in a vented fireplace shall be installed in a fireplace having a permanent free opening, based on appliance input rating and chimney height equal to or greater than that specified in Table 10.6.2.3.

10.6.3 Fireplace Screens. A fireplace screen shall be installed with a decorative appliance for installation in a vented fireplace.

10.7 Gas Fireplaces, Vented.

10.7.1* Prohibited Installations. Vented gas fireplaces shall not be installed in bathrooms or bedrooms unless the appliance is listed and the bedroom or bathroom has the required volume in accordance with 9.3.2.

Exception: Direct vent gas fireplaces.

10.7.2 Installation. The installation of vented gas fireplaces shall comply with the following requirements:

- (1) Listed vented gas fireplaces shall be installed in accordance with the manufacturer's installation instructions and where installed in or attached to combustible material shall be specifically listed for such installation.
- (2) Unlisted vented gas fireplaces shall not be installed in or attached to combustible material and shall also comply with the following:
 - (a) They shall have a clearance at the sides and rear of not less than 18 in. (460 mm).

- (b) Combustible floors under unlisted vented gas fireplaces shall be protected in an approved manner.
 - (c) Unlisted appliances of other than the direct vent type shall be equipped with a draft hood and shall be properly vented in accordance with Chapter 12.
 - (d) Appliances that use metal, asbestos, or ceramic material to direct radiation to the front of the appliance shall have a clearance of 36 in. (910 mm) in front and, if constructed with a double back of metal or ceramic, shall be installed with a minimum clearance of 18 in. (460 mm) at the sides and 12 in. (300 mm) at the rear.
- (3) Panels, grilles, and access doors that are required to be removed for normal servicing operations shall not be attached to the building.
 - (4) Direct vent gas fireplaces shall be installed with the vent air intake terminal in the outdoors and in accordance with the manufacturer's instructions.

10.7.3 Combustion and Circulating Air. Combustion and circulating air shall be provided in accordance with Section 9.3.

10.8 Non-Recirculating Direct Gas-Fired Industrial Air Heaters.

10.8.1 Application. Direct gas-fired industrial air heaters of the non-recirculating type shall be listed in accordance with ANSI Z83.4/CSA 3.7, *Non-Recirculating Direct Gas-Fired Industrial Air Heaters*.

10.8.2 Prohibited Installations.

10.8.2.1 Non-recirculating direct gas-fired industrial air heaters shall not serve any area containing sleeping quarters.

10.8.2.2 Non-recirculating direct gas-fired industrial air heaters shall not recirculate room air.

10.8.3 Installation. Installation of direct gas-fired industrial air heaters shall comply with 10.8.3.1 through 10.8.3.3.

10.8.3.1 Non-recirculating direct gas-fired industrial air heaters shall be installed in accordance with the manufacturer's instructions.

10.8.3.2 Non-recirculating direct gas-fired industrial air heaters shall be permitted to provide fresh air ventilation.

10.8.3.3 Non-recirculating direct gas-fired industrial air heaters shall be provided with access for removal of burners; for replacement of motors, controls, filters, and other working parts; and for adjustment and lubrication of parts requiring maintenance.

10.8.4 Clearance from Combustible Materials. Non-recirculating direct gas-fired industrial air heaters shall be installed with a clearance from combustible materials of not less than that shown on the rating plate and the manufacturer's instructions.

10.8.5 Air Supply. All air to the non-recirculating direct gas-fired industrial air heater shall be ducted directly from outdoors. Where outdoor air dampers or closing louvers are used, they shall be verified to be in the open position prior to main burner operation.

10.8.6 Atmospheric Vents or Gas Reliefs or Bleeds. Non-recirculating direct gas-fired industrial air heaters with valve train components equipped with atmospheric vents, gas reliefs, or bleeds shall have their vent lines, gas reliefs, or bleeds lead to a safe point outdoors. Means shall be employed on these lines to prevent water from entering and to prevent blockage from insects and foreign matter. An atmospheric vent line shall not be required to be provided on a valve train component equipped with a listed vent limiter.

10.8.7 Relief Openings. The design of the installation shall include adequate provisions to permit the non-recirculating direct gas-fired industrial air heater to operate at its rated airflow without overpressurizing the space served by the heater by taking into account the structure's designed infiltration rate, properly designed relief openings, or an interlocked powered exhaust system, or a combination of these methods.

10.8.7.1 The structure's designed infiltration rate and the size of relief opening(s) shall be determined by approved engineering methods.

10.8.7.2 Louver or counterbalanced gravity damper relief openings shall be permitted. Where motorized dampers or closable louvers are used, they shall be proved to be in their open position prior to main burner operation.

10.8.8 Purging. Inlet ducting, when used, shall be purged with at least four air changes prior to an ignition attempt.

10.9 Recirculating Direct Gas-Fired Industrial Air Heaters.

10.9.1 Application. Direct gas-fired industrial air heaters of the recirculating type shall be listed in accordance with ANSI Z83.18, *Recirculating Direct Gas-Fired Industrial Air Heaters*.

10.9.2 Prohibited Installations.

10.9.2.1 Recirculating direct gas-fired industrial air heaters shall not serve any area containing sleeping quarters.

10.9.2.2* Recirculating direct gas-fired industrial air heaters shall not recirculate room air in buildings that contain flammable solids, liquids, or gases; explosive materials; or substances that can become toxic when exposed to flame or heat.

10.9.3 Installation. Recirculating direct gas-fired industrial air heaters shall be installed in accordance with the manufacturer's instructions.

10.9.4 Clearance from Combustible Materials. Recirculating direct gas-fired industrial air heaters shall be installed with a

clearance from combustible materials of not less than that shown on the rating plate and the manufacturer's instructions.

10.9.5 Air Supply. Ventilation air to the recirculating direct gas-fired industrial air heater shall be ducted directly from outdoors. Air to the recirculating direct gas-fired industrial air heater in excess of the minimum ventilation air specified on the heater's rating plate shall be taken from the building, ducted directly from outdoors, or a combination of both. Where outdoor air dampers or closing louvers are used, they shall be verified to be in the open position prior to main burner operation.

10.9.6 Atmospheric Vents, Gas Reliefs, or Bleeds. Recirculating direct gas-fired industrial air heaters with valve train components equipped with atmospheric vents, gas reliefs, or bleeds shall have their vent lines, gas reliefs, or bleeds lead to a safe point outdoors. Means shall be employed on these lines to prevent water from entering and to prevent blockage from insects and foreign matter. An atmospheric vent line shall not be required to be provided on a valve train component equipped with a listed vent limiter.

10.9.7 Relief Openings. The design of the installation shall include adequate provisions to permit the recirculating direct gas-fired industrial air heater to operate at its rated airflow without overpressurizing the space served by the heater, by taking into account the structure's designed infiltration rate, properly designed relief openings, an interlocked powered exhaust system, or a combination of these methods.

10.9.7.1 The structure's designed infiltration rate and the size of relief opening(s) shall be determined by approved engineering methods.

10.9.7.2 Louver or counterbalanced gravity damper relief openings shall be permitted. Where motorized dampers or closable louvers are used, they shall be proved to be in their open position prior to main burner operation.

10.9.8 Purging. Inlet ducting, when used, shall be purged with at least four air changes prior to an ignition attempt.

10.10 Duct Furnaces.

10.10.1 Clearances. The installation of duct furnaces shall comply with the following clearance requirements:

- (1) Listed duct furnaces shall be installed with clearances of at least 6 in. (150 mm) between adjacent walls, ceilings, and floors of combustible material and the furnace draft hood and shall comply with the following:
 - (a) Furnaces listed for installation at lesser clearances shall be installed in accordance with the manufacturer's installation instructions.
 - (b) In no case shall the clearance be such as to interfere with combustion air and accessibility.
- (2) Unlisted duct furnaces shall be installed with clearances to combustible material in accordance with the clearances specified for unlisted furnaces and boilers in Table 10.3.2.2. Combustible floors under unlisted duct furnaces shall be protected in an approved manner.

10.10.2 Installation of Duct Furnaces. Duct furnaces shall be installed in accordance with the manufacturers' instructions.

10.10.3 Access Panels. The ducts connected to duct furnaces shall have removable access panels on both the upstream and downstream sides of the furnace.

10.10.4 Location of Draft Hood and Controls. The controls, combustion air inlet, and draft hoods for duct furnaces shall be located outside the ducts. The draft hood shall be located in the same enclosure from which combustion air is taken.

10.10.5 Circulating Air. Where a duct furnace is installed so that supply ducts carry air circulated by the furnace to areas outside the space containing the furnace, the return air shall also be handled by a duct(s) sealed to the furnace casing and terminating outside the space containing the furnace. The duct furnace shall be installed on the positive-pressure side of the circulating air blower.

10.10.6 Duct Furnaces Used with Refrigeration Systems.

10.10.6.1 A duct furnace shall not be installed in conjunction with a refrigeration coil where circulation of cooled air is provided by the blower.

Exception: Where the blower has sufficient capacity to overcome the external static resistance imposed by the duct system, furnace, and the cooling coil and the air throughput necessary for heating or cooling, whichever is greater.

10.10.6.2 Duct furnaces used in conjunction with cooling appliances shall be installed in parallel with or on the upstream side of cooling coils to avoid condensation within heating elements. With a parallel flow arrangement, the dampers or other means used to control the flow of air shall be sufficiently tight to prevent any circulation of cooled air through the unit.

Exception: Where the duct furnace has been specifically listed for downstream installation.

10.10.6.3 Where duct furnaces are to be located upstream from cooling units, the cooling unit shall be so designed or equipped as to not develop excessive temperatures or pressures.

10.10.6.4 Where a duct furnace is installed downstream of an evaporative cooler or air washer, the heat exchanger shall be constructed of corrosion-resistant materials. Stainless steel, ceramic-coated steel, and an aluminum-coated steel in which the bond between the steel and the aluminum is an iron-aluminum alloy are considered to be corrosion resistant. Air washers operating with chilled water that deliver air below the dew point of the ambient air at the duct furnace shall be considered as refrigeration systems.

10.10.7 Installation in Commercial Garages and Aircraft Hangars. Duct furnaces installed in garages for more than three motor vehicles or in aircraft hangars shall be of a listed type and shall be installed in accordance with 9.1.11 and 9.1.12.

10.11 Floor Furnaces.

10.11.1 Installation. The installation of floor furnaces shall comply with the following requirements:

- (1) Listed floor furnaces shall be installed in accordance with the manufacturers' installation instructions.
- (2) Unlisted floor furnaces shall not be installed in combustible floors.
- (3) Thermostats controlling floor furnaces shall not be located in a room or space that can be separated from the room or space in which the register of the floor furnace is located.

10.11.2 Temperature Limit Controls.

10.11.2.1 Listed automatically operated floor furnaces shall be equipped with temperature limit controls.

10.11.2.2 Unlisted automatically operated floor furnaces shall be equipped with a temperature limit control arranged to shut off the flow of gas to the burner in the event the temperature at the warm air outlet register exceeds 350°F (177°C) above room temperature.

10.11.3 Combustion and Circulating Air. Combustion and circulating air shall be provided in accordance with Section 9.3.

10.11.4 Placement. The following provisions apply to furnaces that serve one story:

- (1) *Floors.* Floor furnaces shall not be installed in the floor of any doorway, stairway landing, aisle, or passageway of any enclosure, public or private, or in an exitway from any such room or space.
- (2) *Walls and Corners.* The register of a floor furnace with a horizontal warm air outlet shall not be placed closer than 6 in. (150 mm) from the nearest wall. A distance of at least 18 in. (460 mm) from two adjoining sides of the floor furnace register to walls shall be provided to eliminate the necessity of occupants walking over the warm air discharge. The remaining sides shall be a minimum of 6 in. (150 mm) from a wall. Wall register models shall not be placed closer than 6 in. (150 mm) to a corner.
- (3) *Draperies.* The furnace shall be placed so that a door, drapery, or similar object cannot be nearer than 12 in. (300 mm) to any portion of the register of the furnace.

10.11.5 Bracing. The space provided for the furnace shall be framed with doubled joists and with headers not lighter than the joists.

10.11.6 Support. Means shall be provided to support the furnace when the floor register is removed.

10.11.7 Clearance. The lowest portion of the floor furnace shall have at least a 6 in. (150 mm) clearance from the general ground level. A reduced clearance to a minimum of 2 in. (50 mm) shall be permitted, provided the lower 6 in. (150 mm) portion of the floor furnace is sealed by the manufacturer to prevent entrance of water. Where these clearances are not present, the ground below and to the sides shall be excavated to form a "basin-like" pit under the furnace so that the required clearance is provided beneath the lowest portion of the furnace. A 12 in. (300 mm) clearance shall be provided on all sides except the control side, which shall have an 18 in. (460 mm) clearance.

10.11.8 Access. The space in which any floor furnace is installed shall be accessible by an opening in the foundation not less than 24 in. × 18 in. (610 mm × 460 mm) or by a trapdoor not less than 24 in. × 24 in. (610 mm × 610 mm) in any cross-section thereof, and a passageway not less than 24 in. × 18 in. (610 mm × 460 mm) in any cross-section thereof.

10.11.9 Seepage Pan. Where the excavation exceeds 12 in. (300 mm) in depth or water seepage is likely to collect, a water-tight copper pan, concrete pit, or other suitable material shall be used, unless adequate drainage is provided or the appliance is sealed by the manufacturer to meet this condition. A copper pan shall be made of not less than 16 oz./ft² (4.9 kg/m²) sheet copper. The pan shall be anchored in place so as to prevent floating, and the walls shall extend at least 4 in. (100 mm)

above the ground level with at least a 6 in. (150 mm) clearance on all sides, except on the control side, which shall have at least an 18 in. (460 mm) clearance.

10.11.10 Wind Protection. Floor furnaces shall be protected, where necessary, against severe wind conditions.

10.11.11 Upper Floor Installations. Listed floor furnaces shall be permitted to be installed in an upper floor, provided the furnace assembly projects below into a utility room, closet, garage, or similar nonhabitable space. In such installations, the floor furnace shall be enclosed completely (entirely separated from the nonhabitable space) with means for air intake to meet the provisions of Section 9.3, with access for servicing, minimum furnace clearances of 6 in. (150 mm) to all sides and bottom, and with the enclosure constructed of Portland cement plaster or metal lath or other noncombustible material.

10.11.12 First Floor Installation. Listed floor furnaces installed in the first or ground floors of buildings shall not be required to be enclosed unless the basements of these buildings have been converted to apartments or sleeping quarters, in which case the floor furnace shall be enclosed as specified for upper floor installations and shall project into a nonhabitable space.

10.12 Food Service Appliance, Floor-Mounted.

10.12.1 Clearance for Listed Appliances. Listed floor-mounted food service appliances, such as ranges for hotels and restaurants, deep fat fryers, unit broilers, kettles, steam cookers, steam generators, and baking and roasting ovens, shall be installed at least 6 in. (150 mm) from combustible material except that at least a 2 in. (50 mm) clearance shall be maintained between a draft hood and combustible material. Floor-mounted food service appliances listed for installation at lesser clearances shall be installed in accordance with the manufacturer's installation instructions. Appliances designed and marked "For use only in noncombustible locations" shall not be installed elsewhere.

10.12.2 Clearance for Unlisted Appliances. Unlisted floor-mounted food service appliances shall be installed to provide a clearance to combustible material of not less than 18 in. (460 mm) from the sides and rear of the appliance and from the vent connector and not less than 48 in. (1.2 m) above cooking tops and at the front of the appliance. Clearances for unlisted appliances installed in partially enclosed areas such as alcoves shall not be reduced. Reduced clearances for unlisted appliances installed in rooms that are not partially enclosed shall be in accordance with Table 10.2.3.

10.12.3 Mounting on Combustible Floor.

10.12.3.1 Listed floor-mounted food service appliances that are listed specifically for installation on floors constructed of combustible material shall be permitted to be mounted on combustible floors in accordance with the manufacturer's installation instructions.

10.12.3.2 Floor-mounted food service appliances that are not listed for mounting on a combustible floor shall be mounted in accordance with 10.12.4 or be mounted in accordance with one of the following:

- (1) Where the appliance is set on legs that provide not less than 18 in. (460 mm) open space under the base of the appliance or where it has no burners and no portion of any oven or broiler within 18 in. (460 mm) of the floor, it

shall be permitted to be mounted on a combustible floor without special floor protection, provided at least one sheet metal baffle is between the burner and the floor.

- (2) Where the appliance is set on legs that provide not less than 8 in. (200 mm) open space under the base of the appliance, it shall be permitted to be mounted on combustible floors, provided the floor under the appliance is protected with not less than $\frac{3}{8}$ in. (9.5 mm) insulating millboard covered with sheet metal not less than 0.0195 in. (0.5 mm) thick. The preceding specified floor protection shall extend not less than 6 in. (150 mm) beyond the appliance on all sides.
- (3) Where the appliance is set on legs that provide not less than 4 in. (100 mm) under the base of the appliance, it shall be permitted to be mounted on combustible floors, provided the floor under the appliance is protected with hollow masonry not less than 4 in. (100 mm) in thickness covered with sheet metal not less than 0.0195 in. (0.5 mm) thick. Such masonry courses shall be laid with ends unsealed and joints matched in such a way as to provide for free circulation of air through the masonry.
- (4) Where the appliance does not have legs at least 4 in. (100 mm) high, it shall be permitted to be mounted on combustible floors, provided the floor under the appliance is protected by two courses of 4 in. (100 mm) hollow clay tile, or equivalent, with courses laid at right angles and with ends unsealed and joints matched in such a way as to provide for free circulation of air through such masonry courses, and covered with steel plate not less than $\frac{3}{16}$ in. (4.8 mm) in thickness.

10.12.4 Installation on Noncombustible Floor.

10.12.4.1 Listed floor-installed food service appliances that are designed and marked "For use only in noncombustible locations" shall be installed on floors of noncombustible construction with noncombustible flooring and surface finish and with no combustible material against the underside thereof, or on noncombustible slabs or arches having no combustible material against the underside thereof.

10.12.4.2 Such construction shall in all cases extend not less than 12 in. (300 mm) beyond the appliance on all sides.

10.12.5 Combustible Material Adjacent to Cooking Top.

Listed and unlisted food service ranges shall be installed to provide clearance to combustible material of not less than 18 in. (460 mm) horizontally for a distance up to 2 ft (0.6 m) above the surface of the cooking top where the combustible material is not completely shielded by high shelving, warming closet, or other system. Reduced combustible material clearances are permitted where protected in accordance with Table 10.2.3.

10.12.6 Use with Casters. Floor-mounted appliances with casters shall be listed for such construction and shall be installed in accordance with the manufacturer's installation instructions for limiting the movement of the appliance to prevent strain on the connection.

10.12.7 Level Installation. Floor-mounted food service appliances shall be installed level on a firm foundation.

10.12.8* Ventilation. Means shall be provided to properly ventilate the space in which a food service appliance is installed to permit proper combustion of the gas.

10.13 Food Service Appliances, Counter Appliances.

10.13.1 Vertical Clearance. A vertical distance of not less than 48 in. (1.2 m) shall be provided between the top of all food service hot plates and griddles and combustible material.

10.13.2 Clearance for Listed Appliances. Listed food service counter appliances such as hot plates and griddles, food and dish warmers, and coffee brewers and urns, where installed on combustible surfaces, shall be set on their own bases or legs and shall be installed with a minimum horizontal clearance of 6 in. (150 mm) from combustible material, except that at least a 2 in. (50 mm) clearance shall be maintained between a draft hood and combustible material. Food service counter appliances listed for installation at lesser clearances shall be installed in accordance with the manufacturer's installation instructions.

10.13.3 Clearance for Unlisted Appliances. Unlisted food service hot plates and griddles shall be installed with a horizontal clearance from combustible material of not less than 18 in. (460 mm). Unlisted gas food service counter appliances, including coffee brewers and urns, waffle bakers, and hot water immersion sterilizers, shall be installed with a horizontal clearance from combustible material of not less than 12 in. (300 mm). Reduced clearances for gas food service counter appliances shall be in accordance with Table 10.2.3. Unlisted food and dish warmers shall be installed with a horizontal clearance from combustible material of not less than 6 in. (150 mm).

10.13.4 Installation of Unlisted Appliances. Unlisted food service counter appliances shall not be set on combustible material unless they have legs that provide not less than 4 in. (100 mm) of open space below the burners and the combustible surface is protected with insulating millboard at least ¼ in. (6 mm) thick covered with sheet metal not less than 0.0122 in. (0.3 mm) thick, or with equivalent protection.

10.14 Household Cooking Appliances.

10.14.1* Installation. Listed floor-mounted and built-in household cooking appliances shall be installed in accordance with the manufacturer's installation instructions.

10.14.2 Clearances. The clearances specified as follows shall not interfere with combustion air, accessibility for operation, and servicing:

- (1) Listed floor-mounted household cooking appliances, where installed on combustible floors, shall be set on their own bases or legs.
- (2) Listed household cooking appliances with listed gas room heater sections shall be installed so that the warm air discharge side shall have a minimum clearance of 18 in. (460 mm) from adjacent combustible material. A minimum clearance of 36 in. (910 mm) shall be provided between the top of the heater section and the bottom of cabinets.
- (3) Unlisted floor-mounted household cooking appliances shall be installed with at least a 6 in. (150 mm) clearance at the back and sides to combustible material. Combustible floors under unlisted appliances shall be protected in an approved manner.
- (4) Unlisted built-in household cooking appliances shall not be installed in, or adjacent to, unprotected combustible material.

10.14.2.1 Vertical Clearance Above Cooking Top. Household cooking appliances shall have a vertical clearance above the cooking top of not less than 30 in. (760 mm) to combustible material or metal cabinets. A minimum clearance of 24 in. (610 mm) is permitted when one of the following is installed:

- (1) The underside of the combustible material or metal cabinet above the cooking top is protected with not less than ¼ in. (6 mm) insulating millboard covered with sheet metal not less than 0.0122 in. (0.3 mm) thick.
- (2) A metal ventilating hood of sheet metal not less than 0.0122 in. (0.3 mm) thick is installed above the cooking top with a clearance of not less than ¼ in. (6 mm) between the hood and the underside of the combustible material or metal cabinet, and the hood is at least as wide as the appliance and is centered over the appliance.
- (3) A listed cooking appliance or microwave oven is installed over a listed cooking appliance and conforms to the terms of the upper appliance's manufacturer's installation instructions.

10.14.3 Level Installation. Cooking appliances shall be installed so that the cooking top, broiler pan, or oven racks are level.

10.15 Illuminating Appliances.

10.15.1 Clearances for Listed Appliances. Listed illuminating appliances shall be installed in accordance with the manufacturer's installation instructions.

10.15.2 Clearances for Unlisted Appliances.

10.15.2.1 Enclosed Type. Clearance shall comply with the following:

- (1) Unlisted enclosed illuminating appliances installed outdoors shall be installed with clearances in any direction from combustible material of not less than 12 in. (300 mm).
- (2) Unlisted enclosed illuminating appliances installed indoors shall be installed with clearances in any direction from combustible material of not less than 18 in. (460 mm).

10.15.2.2 Open-Flame Type. Clearance shall comply with the following:

- (1) Unlisted open-flame illuminating appliances installed outdoors shall have clearances from combustible material not less than that specified in Table 10.15.2.2. The distance from ground level to the base of the burner shall be a minimum of 7 ft (2.1 m) where installed within 2 ft (0.6 m) of walkways. Lesser clearances shall be permitted to be used where acceptable to the authority having jurisdiction.
- (2) Unlisted open-flame illuminating appliances installed outdoors shall be equipped with a limiting orifice or other limiting devices that maintain a flame height consistent with the clearance from combustible material, as given in Table 10.15.2.2.
- (3) Appliances designed for flame heights in excess of 30 in. (760 mm) shall be permitted to be installed if acceptable to the authority having jurisdiction. Such appliances shall be equipped with a safety shutoff device or automatic ignition.
- (4) Unlisted open-flame illuminating appliances installed indoors shall have clearances from combustible material acceptable to the authority having jurisdiction.

▲ **Table 10.15.2.2 Clearances for Unlisted Outdoor Open-Flame Illuminating Appliances**

| Flame Height Above Burner Head (in.) | Minimum Clearance from Combustible Material (ft)* | |
|-----------------------------------------------|------------------------------------------------------------|----------|
| | Horizontal | Vertical |
| 12 | 2 | 6 |
| 18 | 3 | 8 |
| 24 | 3 | 10 |
| 30 | 4 | 12 |

For SI units, 1 in. = 25.4 mm, 1 ft = 0.305 m.

*Measured from the nearest portion of the burner head.

10.15.3 Mounting on Buildings. Illuminating appliances designed for wall or ceiling mounting shall be securely attached to substantial structures in such a manner that they are not dependent on the gas piping for support.

10.15.4 Mounting on Posts. Illuminating appliances designed for post mounting shall be securely and rigidly attached to a post. Posts shall be rigidly mounted. The strength and rigidity of posts greater than 3 ft (0.9 m) in height shall be at least equivalent to that of a 2½ in. (64 mm) diameter post constructed of 0.064 in. (1.6 mm) thick steel or a 1 in. Schedule 40 steel pipe. Posts 3 ft (0.9 m) or less in height shall not be smaller than a ¼ in. Schedule 40 steel pipe. Drain openings shall be provided near the base of posts where water collecting inside the posts is possible.

10.15.5 Appliance Pressure Regulators. Where an appliance pressure regulator is not supplied with an illuminating appliance and the service line is not equipped with a service pressure regulator, an appliance pressure regulator shall be installed in the line serving one or more illuminating appliances.

▲ **10.16 Incinerators, Commercial-Industrial.** Commercial-industrial-type incinerators shall be constructed and installed in accordance with NFPA 82.

10.17 Infrared Heaters.

10.17.1 Support. Suspended-type infrared heaters shall be fixed in position independent of gas and electric supply lines. Hangers and brackets shall be of noncombustible material. Heaters subject to vibration shall be provided with vibration-isolating hangers.

10.17.2 Clearance. The installation of infrared heaters shall meet the following clearance requirements:

- (1) Listed heaters shall be installed with clearances from combustible material in accordance the manufacturer's installation instructions.
- (2) Unlisted heaters shall be installed in accordance with clearances from combustible material acceptable to the authority having jurisdiction.
- (3) In locations used for the storage of combustible materials, signs shall be posted to specify the maximum permissible stacking height to maintain required clearances from the heater to the combustibles.

10.17.3 Combustion and Ventilation Air.

10.17.3.1 Where unvented infrared heaters are used, natural or mechanical means shall be provided to supply and exhaust at least 4 ft³/min/1000 Btu/hr (0.38 m³/min/kW) input of installed heaters.

10.17.3.2 Exhaust openings for removing flue products shall be above the level of the heaters.

10.17.4 Installation in Commercial Garages and Aircraft Hangars. Overhead heaters installed in garages for more than three motor vehicles or in aircraft hangars shall be of a listed type and shall be installed in accordance with 9.1.11 and 9.1.12.

10.18 Open-Top Broiler Units.

10.18.1 Listed Units. Listed open-top broiler units shall be installed in accordance with the manufacturer's installation instructions.

10.18.2 Unlisted Units. Unlisted open-top broiler units shall be installed in accordance with the manufacturers' instructions but shall not be installed in combustible material.

10.18.3 Protection Above Domestic Units. Domestic open-top broiler units shall be provided with a metal ventilating hood not less than 0.0122 in. (0.3 mm) thick with a clearance of not less than ¼ in. (6 mm) between the hood and the underside of combustible material or metal cabinets. A clearance of at least 24 in. (610 mm) shall be maintained between the cooking top and the combustible material or metal cabinet, and the hood shall be at least as wide as the open-top broiler unit and centered over the unit. Listed domestic open-top broiler units incorporating an integral exhaust system and listed for use without a ventilating hood shall not be required to be provided with a ventilating hood if installed in accordance with 10.14.2.1(1).

▲ **10.18.4 Commercial Units.** Commercial open-top broiler units shall be provided with ventilation in accordance with NFPA 96.

10.19 Outdoor Cooking Appliances.

10.19.1 Listed Units. Listed outdoor cooking appliances shall be installed in accordance with the manufacturer's installation instructions.

10.19.2 Unlisted Units. Unlisted outdoor cooking appliances shall be installed outdoors with clearances to combustible material of not less than 36 in. (910 mm) at the sides and back and not less than 48 in. (1220 mm) at the front. In no case shall the appliance be located under overhead combustible construction.

10.20 Pool Heaters.

10.20.1 Location. A pool heater shall be located or protected so as to minimize accidental contact of hot surfaces by persons.

10.20.2 Clearance. The installation of pool heaters shall meet the following requirements:

- (1) In no case shall the clearances be such as to interfere with combustion air, draft hood or vent terminal clearance and relief, and accessibility for servicing.
- (2) A listed pool heater shall be installed in accordance with the manufacturer's installation instructions.
- (3) An unlisted pool heater shall be installed with a minimum clearance of 12 in. (300 mm) on all sides and the

rear. A combustible floor under an unlisted pool heater shall be protected in an approved manner.

10.20.3 Temperature or Pressure Limiting Devices.

10.20.3.1 An unlisted pool heater shall be provided with over-temperature protection or overtemperature and overpressure protection by means of an approved device(s).

10.20.3.2 Where a pool heater is provided with overtemperature protection only and is installed with any device in the discharge line of the heater that can restrict the flow of water from the heater to the pool (such as a check valve, shutoff valve, therapeutic pool valving, or flow nozzles), a pressure relief valve shall be installed either in the heater or between the heater and the restrictive device.

10.20.4 Bypass Valves. Where an integral bypass system is not provided as a part of the pool heater, a bypass line and valve shall be installed between the inlet and outlet piping for use in adjusting the flow of water through the heater.

10.20.5 Venting. A pool heater listed for outdoor installation shall be installed with the venting means supplied by the manufacturer and in accordance with the manufacturer's instructions.

10.21 Refrigerators.

10.21.1 Clearance. Refrigerators shall be provided with clearances for ventilation at the top and back in accordance with the manufacturers' instructions. Where such instructions are not available, at least 2 in. (50 mm) shall be provided between the back of the refrigerator and the wall and at least 12 in. (300 mm) above the top.

10.21.2 Venting or Ventilating Kits Approved for Use with a Refrigerator. Where an accessory kit is used for conveying air for burner combustion or unit cooling to the refrigerator from areas outside the room in which it is located, or for conveying combustion products diluted with air containing waste heat from the refrigerator to areas outside the room in which it is located, the kit shall be installed in accordance with the refrigerator manufacturer's instructions.

10.22 Room Heaters.

10.22.1* Prohibited Installations. Unvented room heaters shall not be installed in bathrooms or bedrooms.

Exception No. 1: Where approved by the authority having jurisdiction, one listed wall-mounted, unvented room heater equipped with an oxygen depletion safety shutoff system shall be permitted to be installed in a bathroom, provided that the input rating does not exceed 6000 Btu/hr (1760 W/hr) and combustion and ventilation air is provided as specified in 10.1.2.

Exception No. 2: Where approved by the authority having jurisdiction, one listed wall-mounted unvented room heater equipped with an oxygen depletion safety shutoff system shall be permitted to be installed in a bedroom, provided that the input rating does not exceed 10,000 Btu/hr (2930 W/hr) and combustion and ventilation air is provided as specified in 10.1.2.

10.22.2 Listing and Installation. Unvented room heaters shall be listed in accordance with ANSI Z21.11.2, *Gas-Fired Room Heaters — Volume II, Unvented Room Heaters*, and shall be installed in accordance with the manufacturer's installation instructions.

10.22.3 Prohibited Installations. Room heaters shall not be installed in the following occupancies:

- (1) Residential board and care
- (2) Health care

▲ 10.22.4 Clearance. A room heater shall be placed so as not to cause a hazard to walls, floors, curtains, furniture, doors when open, and so on, and to the free movements of persons within the room. Heaters designed and marked "For use in noncombustible fireplace only" shall not be installed elsewhere. Listed room heaters shall be installed in accordance with the manufacturer's installation instructions. In no case shall the clearances be such as to interfere with combustion air and accessibility. Unlisted room heaters shall be installed with clearances from combustible material not less than the following:

- (1) *Circulating Type.* Room heaters having an outer jacket surrounding the combustion chamber, arranged with openings at top and bottom so that air circulates between the inner and outer jacket, and without openings in the outer jacket to permit direct radiation, shall have clearance at sides and rear of not less than 12 in. (300 mm).
- (2) *Radiating Type.* Room heaters other than those of the circulating type described in 10.22.4(1) shall have clearance at sides and rear of not less than 18 in. (460 mm), except that heaters that make use of metal, asbestos, or ceramic material to direct radiation to the front of the heater shall have a clearance of 36 in. (910 mm) in front and, if constructed with a double back of metal or ceramic, shall be permitted to be installed with a clearance of 18 in. (460 mm) at sides and 12 in. (300 mm) at rear. Combustible floors under unlisted room heaters shall be protected in an approved manner.

10.22.5 Wall-Type Room Heaters. Wall-type room heaters shall not be installed in or attached to walls of combustible material unless listed for such installation.

▲ 10.23 Stationary Gas Engines. The installation of gas engines shall conform to NFPA 37.

10.23.1 Stationary gas engines shall not be rigidly connected to the gas supply piping.

10.24 Gas-Fired Toilets.

10.24.1 Clearance. A listed gas-fired toilet shall be installed in accordance with the manufacturer's installation instructions, provided that the clearance is in any case sufficient to afford ready accessibility for use, cleanout, and necessary servicing.

10.24.2 Installation on Combustible Floors. Listed gas-fired toilets installed on combustible floors shall be listed for such installation.

10.24.3 Installation. Vents or vent connectors that are capable of being contacted during casual use of the room in which the toilet is installed shall be protected or shielded to prevent such contact.

10.25 Unit Heaters.

10.25.1 Support. Suspended-type unit heaters shall be safely and adequately supported, with due consideration given to their weight and vibration characteristics. Hangers and brackets shall be of noncombustible material.

10.25.2 Clearance.

10.25.2.1 Suspended-Type Unit Heaters. Suspended-type unit heaters shall meet the following requirements:

- (1) A listed unit heater shall be installed with clearances from combustible material of not less than 18 in. (460 mm) at the sides, 12 in. (300 mm) at the bottom, and 6 in. (150 mm) above the top where the unit heater has an internal draft hood, or 1 in. (25 mm) above the top of the sloping side of a vertical draft hood. A unit heater listed for reduced clearances shall be installed in accordance with the manufacturer's installation instructions.
- (2) Unlisted unit heaters shall be installed with clearances to combustible material of not less than 18 in. (460 mm).
- (3) Clearances for servicing shall be in accordance with the manufacturers' recommendations contained in the installation instructions.

10.25.3 Combustion and Circulating Air. Combustion and circulating air shall be provided in accordance with Section 9.3.

10.25.4 Ductwork. A unit heater shall not be attached to a warm air duct system unless listed and marked for such installation.

10.25.5 Installation in Commercial Garages and Aircraft Hangars. Unit heaters installed in garages for more than three motor vehicles or in aircraft hangars shall be of a listed type and shall be installed in accordance with 9.1.11 and 9.1.12.

10.26 Wall Furnaces.

10.26.1 Installation.

10.26.1.1 Listed wall furnaces shall be installed in accordance with the manufacturer's installation instructions. Wall furnaces installed in or attached to combustible material shall be listed for such installation.

10.26.1.2 Unlisted wall furnaces shall not be installed in or attached to combustible material.

10.26.1.3 Vented wall furnaces connected to a Type B-W gas vent system listed only for a single story shall be installed only in single-story buildings or the top story of multistory buildings. Vented wall furnaces connected to a Type B-W gas vent system listed for installation in multistory buildings shall be permitted to be installed in single-story or multistory buildings. Type B-W gas vents shall be attached directly to a solid header plate that serves as a firestop at that point and that shall be permitted to be an integral part of the vented wall furnace, as illustrated in Figure 10.26.1.3. The stud space in which the vented wall furnace is installed shall be ventilated at the first ceiling level by installation of the ceiling plate spacers furnished with the gas vent. Firestop spacers shall be installed at each subsequent ceiling or floor level penetrated by the vent.

10.26.1.4 Direct vent wall furnaces shall be installed with the vent air intake terminal in the outdoors. The thickness of the walls on which the furnace is mounted shall be within the range of wall thickness marked on the furnace and covered in the manufacturers' installation instructions.

10.26.1.5 Panels, grilles, and access doors that are required to be removed for normal servicing operations shall not be attached to the building. (For additional information on the venting of wall furnaces, see Chapter 12.)

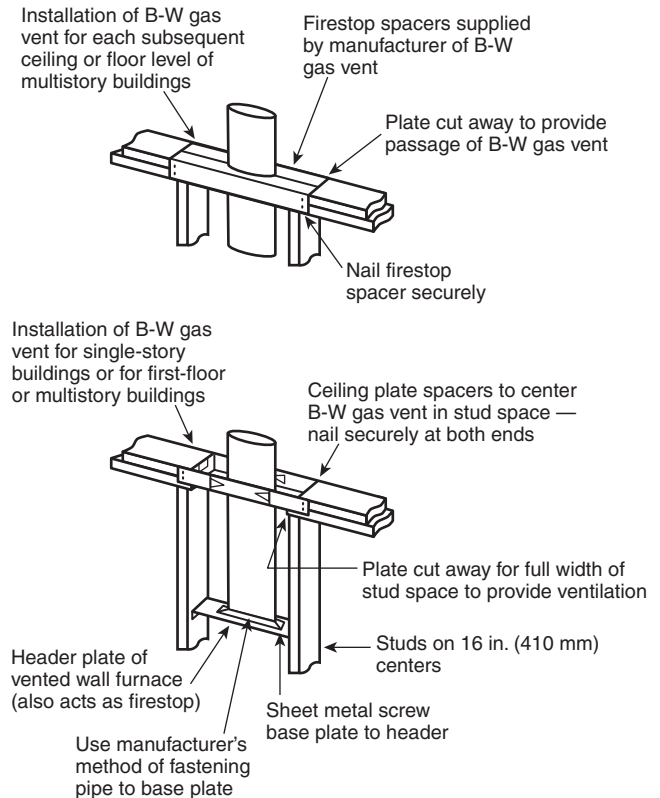

FIGURE 10.26.1.3 Installation of Type B-W Gas Vents for Vented Wall Furnaces.

10.26.2 Location. Wall furnaces shall be located so as not to cause a hazard to walls, floors, curtains, furniture, or doors. Wall furnaces installed between bathrooms and adjoining rooms shall not circulate air from bathrooms to other parts of the building.

10.26.3 Combustion and Circulating Air. Combustion and circulating air shall be provided in accordance with Section 9.3.

10.27 Water Heaters.

10.27.1 Location. Water heater installations in bedrooms and bathrooms shall comply with one of the following:

- (1) Water heater shall be installed in a closet equipped with a weather-stripped door with no openings and with a self-closing device. All combustion air shall be obtained from the outdoors in accordance with 9.3.3.
- (2) Water heater shall be of the direct vent type.

10.27.1.1 Locations with Airhandlers. Where a draft hood-equipped water heater is installed in a space containing a furnace or other air handler, the ducts serving the furnace or air handler shall comply with 10.3.7.4.

10.27.2 Clearance.

10.27.2.1 The clearances shall not be such as to interfere with combustion air, draft hood clearance and relief, and accessibility for servicing. Listed water heaters shall be installed in accordance with the manufacturer's installation instructions.

10.27.2.2 Unlisted water heaters shall be installed with a clearance of 12 in. (300 mm) on all sides and rear. Combustible

floors under unlisted water heaters shall be protected in an approved manner.

10.27.3 Pressure Limiting Devices. A water heater installation shall be provided with overpressure protection by means of an approved, listed device installed in accordance with the manufacturer's installation instructions. The pressure setting of the device shall exceed the water service pressure and shall not exceed the maximum pressure rating of the water heater.

10.27.4 Temperature Limiting Devices. A water heater installation or a hot water storage vessel installation shall be provided with overtemperature protection by means of an approved, listed device installed in accordance with the manufacturer's installation instructions.

10.27.5 Temperature, Pressure, and Vacuum Relief Devices. Temperature, pressure, and vacuum relief devices or combinations thereof, and automatic gas shutoff devices, shall be installed in accordance with the manufacturer's installation instructions. A shutoff valve shall not be placed between the relief valve and the water heater or on discharge pipes between such valves and the atmosphere. The hourly Btu discharge capacity or the rated steam relief capacity of the device shall not be less than the input rating of the water heater.

10.27.6 Automatic Instantaneous Type: Cold Water Supply. The water supply to an automatic instantaneous water heater that is equipped with a water flow-actuated control shall be such as to provide sufficient pressure to properly operate the control when water is drawn from the highest faucet served by the heater.

10.27.7* Antisiphon Devices. Means acceptable to the authority having jurisdiction shall be provided to prevent siphoning in any water heater or any tank to which a circulating water heater that incorporates a cold water inlet tube is attached.

Δ 10.28 Compressed Natural Gas (CNG) Vehicular Fuel Systems. The installation of compressed natural gas (CNG) fueling (dispensing) systems shall conform to NFPA 52. Residential CNG fueling appliances shall be listed in accordance with ANSI/CSA NGV 5.1, *Residential Fueling Appliances*, and installed in accordance to the appliance manufacturer's installation instructions.

10.29 Appliances for Installation in Manufactured Housing. Appliances installed in manufactured housing after the initial sale shall be listed for installation in manufactured housing, or approved, and shall be installed in accordance with the requirements of this code and the manufacturers' installation instructions. Appliances installed in the living space of manufactured housing shall be in accordance with the requirements of Section 9.3.

Δ 10.30 Fuel Cell Power Plants. Fuel cell power plants with a power output of less than 50 kW shall be listed and installed in accordance with the manufacturer's instructions. Fuel cell power plants with a power output of greater than 50 kW shall be installed in accordance with NFPA 853.

10.31 Outdoor Open Flame Decorative Appliances. Permanently fixed in place outdoor open flame decorative appliances shall be installed in accordance with 10.31.1 through 10.31.3.

10.31.1 Listed Units. Listed outdoor open flame decorative appliances shall be installed in accordance with the manufacturer's installation instructions.

10.31.2 Unlisted Units. Unlisted outdoor open flame decorative appliances shall be installed outdoors in accordance with the manufacturer's installation instructions and with clearances to combustible material of not less than 36 in. (910 mm) from the sides. In no case shall the appliance be located under overhead combustible construction.

10.31.3 Connection to Piping System. The connection to the gas piping system shall be in accordance with 9.6.1(1), (2), (4), or (5).

Chapter 11 Procedures to Be Followed to Place Appliance in Operation

11.1 Adjusting the Burner Input.

11.1.1* Adjusting Input. The input rate of the burner shall be adjusted to the proper value in accordance with the appliance manufacturer's instructions. Firing at a rate in excess of the nameplate rating shall be prohibited.

11.1.1.1 The input rate can be adjusted by either changing the size of a fixed orifice, changing the adjustment of an adjustable orifice, or readjusting the appliance's gas pressure regulator outlet pressure (where a regulator is provided in the appliance).

Δ 11.1.1.2 The input rate shall be determined by one of the following:

- (1) Checking burner input by using a gas meter
- (2) Checking burner input by using manifold pressure and orifice size

11.1.1.3 Overfiring shall be prohibited.

11.1.2 High Altitude. Gas input ratings of appliances shall be used for elevations up to 2000 ft (600 m). The input ratings of appliances operating at elevations above 2000 ft (600 m) shall be reduced in accordance with one of the following methods:

- (1) At the rate of 4 percent for each 1000 ft (300 m) above sea level before selecting appropriately sized appliance
- (2) As permitted by the authority having jurisdiction
- (3) In accordance with the manufacturer's installation instructions

11.2* Primary Air Adjustment. The primary air for injection (Bunsen)-type burners shall be adjusted for proper flame characteristics in accordance with the appliance manufacturer's instructions. After setting the primary air, the adjustment means shall be secured in position.

11.3 Safety Shutoff Devices. Where a safety shutoff device is provided, it shall be checked for proper operation and adjustment in accordance with the appliance manufacturer's instructions. Where the device does not function properly to turn off the gas supply in the event of pilot outage or other improper operation, it shall be properly serviced or replaced with a new device.

11.4 Automatic Ignition. Appliances supplied with means for automatic ignition shall be checked for operation within the parameters provided by the manufacturer. Any adjustments made shall be in accordance with the manufacturer's installation instructions.

11.5 Protective Devices. Where required by the manufacturer's installation instructions, all protective devices furnished

with the appliance, such as a limit control, fan control to blower, temperature and pressure relief valve, low-water cutoff device, or manual operating features, shall be checked for operation within the parameters provided by the manufacturer. Any adjustments made shall be in accordance with the manufacturer's installation instructions.

11.6* Checking the Draft. Draft hood-equipped appliances shall be checked to verify that there is no draft hood spillage after 5 minutes of main burner operation.

11.7 Operating Instructions. Operating instructions shall be furnished and shall be left in a prominent position near the appliance for use by the consumer.

Chapter 12 Venting of Appliances

12.1* Minimum Safe Performance. Venting systems shall be designed and constructed to convey all flue and vent gases to the outdoors.

12.2 General.

12.2.1 Installation. Listed vents shall be installed in accordance with Chapter 12 and the manufacturers' installation instructions.

12.3 Specification for Venting.

12.3.1 Connection to Venting Systems. Except as permitted in 12.3.2 through 12.3.6, all appliances shall be connected to venting systems.

Δ 12.3.2 Appliances Not Required to Be Vented. The following appliances shall not be required to be vented:

- (1) Listed ranges
- (2) Built-in domestic cooking units listed and marked for optional venting
- (3) Listed hot plates
- (4) Listed Type 1 clothes dryers exhausted in accordance with Section 10.4
- (5) A single listed booster-type (automatic instantaneous) water heater, when designed and used solely for the sanitizing rinse requirements of a dishwashing machine, provided that the appliance is installed with the draft hood in place and unaltered, if a draft hood is required, in a commercial kitchen having a mechanical exhaust system [Where installed in this manner, the draft hood outlet shall not be less than 36 in. (910 mm) vertically and 6 in. (150 mm) horizontally from any surface other than the appliance.]
- (6) Listed refrigerators
- (7) Counter appliances
- (8) Room heaters listed for unvented use
- (9) Direct gas-fired make-up air heaters
- (10) Other appliances listed for unvented use and not provided with flue collars
- (11) Specialized appliances of limited input such as laboratory burners or gas lights

Δ 12.3.2.1 Where any or all of the appliances in 12.3.2(5) through 12.3.2(11) are installed so the aggregate input rating exceeds 20 Btu/hr/ft³ (207 W/m³) of room or space in which it is installed, one or more shall be provided with venting systems or other approved means for conveying the vent gases to the outdoors so that the aggregate input rating of the

remaining unvented appliances does not exceed 20 Btu/hr/ft³ (207 W/m³).

12.3.2.2 Where the calculation includes the volume of an adjacent room or space, the room or space in which the appliances are installed shall be directly connected to the adjacent room or space by a doorway, archway, or other opening of comparable size that cannot be closed.

12.3.3* Ventilating Hoods. The use of ventilating hoods and exhaust systems to vent appliances shall be limited to industrial appliances and appliances installed in commercial applications.

Δ 12.3.4 Well-Ventilated Spaces. The flue gases from industrial-type appliances shall not be required to be vented to the outdoors where such gases are discharged into a large and well-ventilated industrial space.

12.3.5 Direct Vent Appliances. Listed direct vent appliances shall be installed in accordance with the manufacturer's installation instructions and 12.9.3.

12.3.6 Appliances with Integral Vents. Appliances incorporating integral venting means shall be installed in accordance with the manufacturer's installation instructions and 12.9.1 and 12.9.2.

Δ 12.3.7 Incinerators, Commercial-Industrial. Commercial-industrial-type incinerators shall be vented in accordance with NFPA 82.

12.4 Design and Construction.

12.4.1 Appliance Draft Requirements. A venting system shall satisfy the draft requirements of the appliance in accordance with the manufacturer's instructions.

12.4.2 Design and Construction. Appliances required to be vented shall be connected to a venting system designed and installed in accordance with the provisions of Sections 12.5 through 12.16.

12.4.3 Mechanical Draft Systems.

12.4.3.1 Mechanical draft systems shall be listed in accordance with UL 378, *Draft Equipment*, and installed in accordance with both the appliance and the mechanical draft system manufacturer's installation instructions.

12.4.3.2 Appliances requiring venting shall be permitted to be vented by means of mechanical draft systems of either forced or induced draft design.

12.4.3.3 Forced draft systems and all portions of induced draft systems under positive pressure during operation shall be designed and installed so as to prevent leakage of flue or vent gases into a building.

12.4.3.4 Vent connectors serving appliances vented by natural draft shall not be connected into any portion of mechanical draft systems operating under positive pressure.

12.4.3.5 Where a mechanical draft system is employed, provision shall be made to prevent the flow of gas to the main burners when the draft system is not performing so as to satisfy the operating requirements of the appliance for safe performance.

12.4.3.6 The exit terminals of mechanical draft systems shall be not less than 7 ft (2.1 m) above finished ground level where located adjacent to public walkways and shall be located as specified in 12.9.1 and 12.9.2.

12.4.4* Ventilating Hoods and Exhaust Systems.

12.4.4.1 Where automatically operated appliances, other than commercial cooking appliances, are vented through a ventilating hood or exhaust system equipped with a damper or with a power means of exhaust, provisions shall be made to allow the flow of gas to the main burners only when the damper is open to a position to properly vent the appliance and when the power means of exhaust is in operation.

12.4.5 Circulating Air Ducts, Above-Ceiling Air-Handling Spaces, and Furnace Plenums.

12.4.5.1 Venting systems shall not extend into or pass through any fabricated air duct or furnace plenum.

12.4.5.2 Where a venting system passes through an above-ceiling air space or other nonducted portion of an air-handling system, it shall conform to one of the following requirements:

- (1) The venting system shall be a listed special gas vent, other system serving a Category III or Category IV appliance, or other positive pressure vent, with joints sealed in accordance with the appliance or vent manufacturer's instructions.
- (2) The vent system shall be installed such that no fittings or joints between sections are installed in the above-ceiling space.
- (3) The venting system shall be installed in a conduit or enclosure with joints between the interior of the enclosure and the ceiling space sealed.

12.5 Type of Venting System to Be Used.

▲ **12.5.1** The type of venting system to be used shall be in accordance with Table 12.5.1.

12.5.2 Plastic Piping. Where plastic piping is used to vent an appliance, the appliance shall be listed for use with such venting materials and the appliance manufacturer's installation instructions shall identify the specific plastic piping material. The plastic pipe venting materials shall be labeled in accordance with the product standards specified by the appliance manufacturer or shall be listed and labeled in accordance with ANSI/UL 1738, *Venting Systems for Gas-Burning Appliances, Categories II, III, and IV.*

12.5.3 Plastic Vent Joints. Plastic pipe and fittings used to vent appliances shall be installed in accordance with the appliance manufacturer's installation instructions. Plastic pipe venting materials listed and labeled in accordance with ANSI/UL 1738, *Venting Systems for Gas-Burning Appliances, Categories II, III, and IV,* shall be installed in accordance with the vent manufacturer's installation instructions. Where primer is required, it shall be of a contrasting color.

12.5.4 Special Gas Vents. Special gas vents shall be listed and labeled in accordance with ANSI/UL 1738, *Venting Systems for Gas-Burning Appliances, Categories II, III, and IV,* and installed in accordance with the special gas vent manufacturer's installation instructions.

12.6 Masonry, Metal, and Factory-Built Chimneys.

12.6.1 Listing or Construction.

12.6.1.1 Factory-built chimneys shall be listed in accordance with ANSI/UL 103, *Chimneys, Factory-Built, Residential Type and Building Heating Appliances;* ANSI/UL 959, *Medium Heat Appliance Factory-Built Chimneys;* or ANSI/UL 2561, *1400 Degree*

▲ **Table 12.5.1 Type of Venting System to Be Used**

| Appliances | Type of Venting System | Location of Requirements |
|-------------------------------------------------------|-----------------------------------------------------------------|--------------------------|
| Listed Category I appliances | Type B gas vent | 12.7 |
| | Chimney | 12.6 |
| | Single-wall metal pipe | 12.8 |
| Listed appliances equipped with draft hood | Listed chimney lining system for gas venting | 12.6.1.3 |
| Appliances listed for use with Type B gas vent | Special gas vent listed for these appliances | 12.5.4 |
| Listed vented wall furnaces | Type B-W gas vent | 12.7, 10.26 |
| Category II, Category III, and Category IV appliances | As specified or furnished by manufacturers of listed appliances | 12.5.2, 12.5.4 |
| Incinerators | In accordance with NFPA 82 | |
| Appliances that can be converted to use solid fuel | | |
| Unlisted combination gas- and oil-burning appliances | | |
| Combination gas- and solid fuel-burning appliances | Chimney | 12.6 |
| Appliances listed for use with chimneys only | | |
| Unlisted appliances | | |
| Listed combination gas- and oil-burning appliances | Type L vent | 12.7 |
| | Chimney | 12.6 |
| Decorative appliance in vented fireplace | Chimney | 10.6.2 |
| Gas-fired toilets | Single-wall metal pipe | 12.8, 10.24.3 |
| Direct vent appliances | 12.3.5 | |
| Appliances with integral vents | 12.3.6 | |

Fahrenheit Factory-Built Chimneys. Factory-built chimneys shall be installed in accordance with the manufacturer's installation instructions. Factory-built chimneys used to vent appliances that operate at positive vent pressure shall be listed for such application.

▲ **12.6.1.2** Metal chimneys shall be built and installed in accordance with NFPA 211.

12.6.1.3* Masonry chimneys shall be built and installed in accordance with NFPA 211 and lined with one of the following:

- (1) Approved clay flue lining
- (2) A chimney lining system listed and labeled in accordance with ANSI/UL 1777, *Chimney Liners*
- (3) Other approved material that resists corrosion, erosion, softening, or cracking from vent gases at temperatures up to 1800°F (982°C)

Exception: Masonry chimney flues lined with a chimney lining system specifically listed for use with listed appliances with draft hoods, Category I appliances, and other appliances listed for use with Type B vents shall be permitted. The liner shall be installed in accordance with the liner manufacturer's installation instructions. A permanent identifying label shall be attached at the point where the connection is to be made to the liner. The label shall read "This chimney liner is for appliances that burn gas only. Do not connect to solid or liquid fuel-burning appliances or incinerators."

12.6.2 Termination.

12.6.2.1* A chimney for residential-type or low-heat appliances shall extend at least 3 ft (0.9 m) above the highest point where it passes through a roof of a building and at least 2 ft (0.6 m) higher than any portion of a building within a horizontal distance of 10 ft (3 m).

12.6.2.2 A chimney for medium-heat appliances shall extend at least 10 ft (3 m) higher than any portion of any building within 25 ft (7.6 m).

12.6.2.3 A chimney shall extend at least 5 ft (1.5 m) above the highest connected appliance draft hood outlet or flue collar.

12.6.2.4 Decorative shrouds shall not be installed at the termination of factory-built chimneys except where such shrouds are listed and labeled for use with the specific factory-built chimney system and are installed in accordance with the manufacturers' installation instructions.

12.6.3 Size of Chimneys.

12.6.3.1 The effective area of a chimney venting system serving listed appliances with draft hoods, Category I appliances, and other appliances listed for use with Type B vents shall be in accordance with one of the following methods:

- (1) Those listed in Chapter 13.
- (2) For sizing an individual chimney venting system for a single appliance with a draft hood, the effective areas of the vent connector and chimney flue shall be not less than the area of the appliance flue collar or draft hood outlet or greater than seven times the draft hood outlet area.
- (3) For sizing a chimney venting system connected to two appliances with draft hoods, the effective area of the chimney flue shall be not less than the area of the larger draft hood outlet plus 50 percent of the area of the smaller draft hood outlet or greater than seven times the smaller draft hood outlet area.

- (4) Chimney venting systems using mechanical draft shall be sized in accordance with approved engineering methods.
- (5) Other approved engineering methods.

12.6.4 Inspection of Chimneys.

12.6.4.1 Before replacing an existing appliance or connecting a vent connector to a chimney, the chimney passageway shall be examined to ascertain that it is clear and free of obstructions and shall be cleaned if previously used for venting solid or liquid fuel-burning appliances or fireplaces.

▲ **12.6.4.2** Chimneys shall be lined in accordance with NFPA 211.

Exception: Existing chimneys shall be permitted to have their use continued when an appliance is replaced by an appliance of similar type, input rating, and efficiency, where the chimney complies with 12.6.4 and the sizing of the chimney is in accordance with 12.6.3.

12.6.4.3 Cleanouts shall be examined and where they do not remain tightly closed when not in use, they shall be repaired or replaced.

12.6.4.4 When inspection reveals that an existing chimney is not safe for the intended application, it shall be repaired, rebuilt, lined, relined, or replaced with a vent or chimney to conform to NFPA 211 and shall be suitable for the appliances to be attached.

12.6.5 Chimney Serving Appliances Burning Other Fuels.

12.6.5.1 An appliance shall not be connected to a chimney flue serving a separate appliance designed to burn solid fuel.

12.6.5.2 Where one chimney serves gas appliances and liquid fuel-burning appliances, the appliances connected through separate openings or connected through a single opening where joined by a suitable fitting located as close as practical to the chimney. Where two or more openings are provided into one chimney flue, they shall be at different levels. Where the gas appliance is automatically controlled, it shall be equipped with a safety shutoff device.

12.6.5.3* A listed combination gas- and solid fuel-burning appliance connected to a single chimney flue shall be equipped with a manual reset device to shut off gas to the main burner in the event of sustained backdraft or flue gas spillage. The chimney flue shall be sized to properly vent the appliance.

12.6.5.4 A single chimney flue serving a listed combination gas- and oil-burning appliance shall be sized in accordance with the appliance manufacturer's instructions.

12.6.6 Support of Chimneys. All portions of chimneys shall be supported for the design and weight of the materials employed. Listed factory-built chimneys shall be supported and spaced in accordance with the manufacturer's installation instructions.

12.6.7 Cleanouts. Where a chimney that formerly carried flue products from liquid or solid fuel-burning appliances is used with an appliance using fuel gas, an accessible cleanout shall be provided. The cleanout shall have a tight-fitting cover and be installed so its upper edge is at least 6 in. (150 mm) below the lower edge of the lowest chimney inlet opening.

12.6.8 Space Surrounding Lining or Vent.

12.6.8.1 The remaining space surrounding a chimney liner, gas vent, special gas vent, or plastic piping installed within a masonry chimney shall not be used to vent another appliance.

Exception: The insertion of another liner or vent within the chimney as provided in this code and the liner or vent manufacturer's instructions.

12.6.8.2 The remaining space surrounding a chimney liner, gas vent, special gas vent, or plastic piping installed within a masonry, metal, or factory-built chimney flue shall not be used to supply combustion air.

Exception: Direct vent appliances designed for installation in a solid fuel-burning fireplace where installed in accordance with the manufacturer's installation instructions.

N 12.6.9 Insulation Shield. Where a factory-built chimney passes through insulated assemblies, an insulation shield constructed of steel having a minimum thickness of 0.0187 in. (0.4712 mm) (nominal 26 gage) shall be installed to provide clearance between the chimney and the insulation material. The clearance shall not be less than the clearance to combustibles specified by the chimney manufacturer's installation instructions. Where chimneys pass through attic space, the shield shall terminate not less than 2 in. (51 mm) above the insulation materials and shall be secured in place to prevent displacement. Insulation shields provided as part of a listed chimney system shall be installed in accordance with the manufacturer's installation instructions.

12.7 Gas Vents.

N 12.7.1 Materials. Type B and Type BW gas vents shall be listed in accordance with ANSI/UL 441, *Gas Vents*. Vents for listed combination gas- and oil-burning appliances shall be listed in accordance with ANSI/UL 641, *Type L Low-Temperature Venting Systems*.

12.7.2 Installation. The installation of gas vents shall meet the following requirements:

- (1) Gas vents shall be installed in accordance with the manufacturer's installation instructions.
- (2) A Type B-W gas vent shall have a listed capacity not less than that of the listed vented wall furnace to which it is connected.
- (3) Gas vents installed within masonry chimneys shall be installed in accordance with the manufacturer's installation instructions. Gas vents installed within masonry chimneys shall be identified with a permanent label installed at the point where the vent enters the chimney. The label shall contain the following language: "This gas vent is for appliances that burn gas. Do not connect to solid or liquid fuel-burning appliances or incinerators."
- (4) Screws, rivets, and other fasteners shall not penetrate the inner wall of double-wall gas vents, except at the transition from the appliance draft hood outlet, flue collar, or single-wall metal connector to a double-wall vent.

12.7.3 Gas Vent Termination. The termination of gas vents shall comply with the following requirements:

- (1) A gas vent shall terminate in accordance with one of the following:
 - (a) Gas vents that are 12 in. (300 mm) or less in size and located not less than 8 ft (2.4 m) from a vertical wall or similar obstruction shall terminate above the

roof in accordance with Figure 12.7.3 and Table 12.7.3.

- (b) Gas vents that are over 12 in. (300 mm) in size or are located less than 8 ft (2.4 m) from a vertical wall or similar obstruction shall terminate not less than 2 ft (0.6 m) above the highest point where they pass through the roof and not less than 2 ft (0.6 m) above any portion of a building within 10 ft (3.0 m) horizontally.
 - (c) Industrial appliances as provided in 12.3.4.
 - (d) Direct vent systems as provided in 12.3.5.
 - (e) Appliances with integral vents as provided in 12.3.6.
 - (f) Mechanical draft systems as provided in 12.4.3.
 - (g) Ventilating hoods and exhaust systems as provided in 12.4.4.
- (2) A Type B or a Type L gas vent shall terminate at least 5 ft (1.5 m) in vertical height above the highest connected appliance draft hood or flue collar.
 - (3) A Type B-W gas vent shall terminate at least 12 ft (3.7 m) in vertical height above the bottom of the wall furnace.
 - (4) A gas vent extending through an exterior wall shall not terminate adjacent to the wall or below eaves or parapets, except as provided in 12.3.5 and 12.4.3.
 - (5) Decorative shrouds shall not be installed at the termination of gas vents except where such shrouds are listed for use with the specific gas venting system and are installed in accordance with the manufacturer's installation instructions.
 - (6) All gas vents shall extend through the roof flashing, roof jack, or roof thimble and terminate with a listed cap or listed roof assembly.
 - (7) A gas vent shall terminate at least 3 ft (0.9 m) above a forced air inlet located within 10 ft (3.0 m).

Δ 12.7.4 Size of Gas Vents. Venting systems shall be sized and constructed in accordance with 12.7.4.1 through 12.7.4.3 and the appliance manufacturer's instructions.

12.7.4.1* Category I Appliances. The sizing of natural draft venting systems serving one or more listed appliances equipped with a draft hood or appliances listed for use with a Type B gas vent, installed in a single story of a building, shall be in accordance with one of the following:

- (1) The provisions of Chapter 13.
- (2) Vents serving fan-assisted combustion system appliances, or combinations of fan-assisted combustion system and draft hood-equipped appliances, shall be sized in accordance with Chapter 13 or other approved engineering methods.
- (3) For sizing an individual gas vent for a single, draft hood-equipped appliance, the effective area of the vent connector and the gas vent shall be not less than the area of the appliance draft hood outlet or greater than seven times the draft hood outlet area.
- (4) For sizing a gas vent connected to two appliances with draft hoods, the effective area of the vent shall be not less than the area of the larger draft hood outlet plus 50 percent of the area of the smaller draft hood outlet or greater than seven times the smaller draft hood outlet area.
- (5) Other approved engineering practices.

Δ 12.7.4.2 Vent Offsets. Type B and Type L vents sized in accordance with 12.7.4.1(3) or 12.7.4.1(4) shall extend in a generally vertical direction with offsets not exceeding

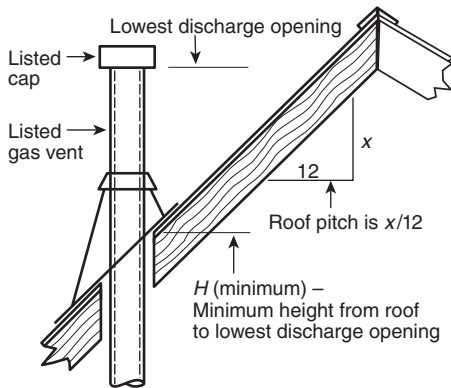

FIGURE 12.7.3 Termination Locations for Gas Vents with Listed Caps 12 in. (300 mm) or Less in Size at Least 8 ft (2.4 m) from a Vertical Wall.

45 degrees, except that a vent system having not more than one 60 degree offset shall be permitted. Any angle greater than 45 degrees from the vertical is considered horizontal. The total horizontal distance of a vent plus the horizontal vent connector serving draft hood-equipped appliances shall not be greater than 75 percent of the vertical height of the vent.

12.7.4.3 Category II, Category III, and Category IV Appliances. The sizing of gas vents for Category II, Category III, and Category IV appliances shall be in accordance with the appliance manufacturer's instructions. The sizing of plastic pipe specified by the appliance manufacturer as a venting material for Category II, III, and IV appliances shall be in accordance with the appliance manufacturers' instructions.

12.7.4.4 Sizing. Chimney venting systems using mechanical draft shall be sized in accordance with approved engineering methods.

Table 12.7.3 Roof Slope Heights

| Roof Slope | H (minimum) | |
|---------------------|-------------|------|
| | ft | m |
| Flat to 6/12 | 1.0 | 0.30 |
| Over 6/12 to 7/12 | 1.25 | 0.38 |
| Over 7/12 to 8/12 | 1.5 | 0.46 |
| Over 8/12 to 9/12 | 2.0 | 0.61 |
| Over 9/12 to 10/12 | 2.5 | 0.76 |
| Over 10/12 to 11/12 | 3.25 | 0.99 |
| Over 11/12 to 12/12 | 4.0 | 1.22 |
| Over 12/12 to 14/12 | 5.0 | 1.52 |
| Over 14/12 to 16/12 | 6.0 | 1.83 |
| Over 16/12 to 18/12 | 7.0 | 2.13 |
| Over 18/12 to 20/12 | 7.5 | 2.27 |
| Over 20/12 to 21/12 | 8.0 | 2.44 |

12.7.5 Gas Vents Serving Appliances on More than One Floor.

12.7.5.1 A common vent shall be permitted in multistory installations to vent Category I appliances located on more than one floor level, provided the venting system is designed and installed in accordance with approved engineering methods. For the purpose of this section, crawl spaces, basements, and attics shall be considered floor levels.

12.7.5.2* All appliances connected to the common vent shall be located in rooms separated from occupiable space. Each of these rooms shall have provisions for an adequate supply of combustion, ventilation, and dilution air that is not supplied from occupiable space.

12.7.5.3 The size of the connectors and common segments of multistory venting systems for appliances listed for use with a Type B double-wall gas vent shall be in accordance with Table 13.2(a), provided all of the following apply:

- (1) The available total height (H) for each segment of a multistory venting system is the vertical distance between the level of the highest draft hood outlet or flue collar on that floor and the centerline of the next highest interconnection tee.
- (2) The size of the connector for a segment is determined from the appliance's gas input rate and available connector rise and shall not be smaller than the draft hood outlet or flue collar size.
- (3) The size of the common vertical vent segment, and of the interconnection tee at the base of that segment, is based on the total appliance's gas input rate entering that segment and its available total height.

12.7.6 Support of Gas Vents. Gas vents shall be supported and spaced in accordance with the manufacturer's installation instructions.

12.7.7 Marking. In those localities where solid and liquid fuels are used extensively, gas vents shall be permanently identified by a label attached to the wall or ceiling at a point where the vent connector enters the gas vent. The label shall read: "This gas vent is for appliances that burn gas. Do not connect to solid or liquid fuel-burning appliances or incinerators." The authority having jurisdiction shall determine whether its area constitutes such a locality.

12.8 Single-Wall Metal Pipe.

12.8.1 Construction. Single-wall metal pipe shall be constructed of galvanized sheet steel not less than 0.0304 in. (0.7 mm) thick or of other approved, noncombustible, corrosion-resistant material.

12.8.2* Cold Climate. Uninsulated single-wall metal pipe shall not be used outdoors for venting appliances in regions where the 99 percent winter design temperature is below 32°F (0°C).

12.8.3 Termination. The termination of single-wall metal pipe shall meet the following requirements:

- (1) Single-wall metal pipe shall terminate at least 5 ft (1.5 m) in vertical height above the highest connected appliance draft hood outlet or flue collar.
- (2) Single-wall metal pipe shall extend at least 2 ft (0.6 m) above the highest point where it passes through a roof of a building and at least 2 ft (0.6 m) higher than any

portion of a building within a horizontal distance of 10 ft (3 m).

- (3) An approved cap or roof assembly shall be attached to the terminus of a single-wall metal pipe.

12.8.4 Installation with Appliances Permitted by 12.5.1.

12.8.4.1* Prohibited Use. Single-wall metal pipe shall not be used as a vent in dwellings and residential occupancies.

12.8.4.2 Single-wall metal pipe shall be used only for runs directly from the space in which the appliance is located through the roof or exterior wall to the outer air. A pipe passing through a roof shall extend without interruption through the roof flashing, roof jacket, or roof thimble.

12.8.4.3 Single-wall metal pipe shall not originate in any unoccupied attic or concealed space and shall not pass through any attic, inside wall, concealed space, or floor.

12.8.4.4 Minimum clearances from single-wall metal pipe to combustible material shall be in accordance with Table 12.8.4.4. Reduced clearances from single-wall metal pipe to combustible material shall be as specified for vent connectors in Table 10.2.3.

12.8.4.5 Where a single-wall metal pipe passes through a roof constructed of combustible material, a noncombustible, nonventilating thimble shall be used at the point of passage. The thimble shall extend at least 18 in. (460 mm) above and 6 in. (150 mm) below the roof with the annular space open at the bottom and closed only at the top. The thimble shall be sized in accordance with 12.8.4.6.

12.8.4.6 Single-wall metal pipe shall not pass through a combustible exterior wall unless guarded at the point of passage by a ventilated metal thimble not smaller than the following:

- (1) For listed appliances with draft hoods and appliances listed for use with Type B gas vents, the thimble shall be a minimum of 4 in. (100 mm) larger in diameter than the metal pipe. Where there is a run of not less than 6 ft

(1.8 m) of metal pipe in the opening between the draft hood outlet and the thimble, the thimble shall be a minimum of 2 in. (50 mm) larger in diameter than the metal pipe.

- (2) For unlisted appliances having draft hoods, the thimble shall be a minimum of 6 in. (150 mm) larger in diameter than the metal pipe.
- (3) For residential and low-heat appliances, the thimble shall be a minimum of 12 in. (300 mm) larger in diameter than the metal pipe.

Exception: In lieu of thimble protection, all combustible material in the wall shall be removed a sufficient distance from the metal pipe to provide the specified clearance from such metal pipe to combustible material. Any material used to close up such opening shall be noncombustible.

12.8.5 Size of Single-Wall Metal Pipe. Single-wall metal piping shall comply with the following requirements:

- (1)* A venting system of a single-wall metal pipe shall be sized in accordance with one of the following methods and the appliance manufacturer’s instructions:
 - (a) For a draft hood–equipped appliance, in accordance with Chapter 13
 - (b) For a venting system for a single appliance with a draft hood, the areas of the connector and the pipe each shall not be less than the area of the appliance flue collar or draft hood outlet, whichever is smaller. The vent area shall not be greater than seven times the draft hood outlet area.
 - (c) Other approved engineering methods
- (2) Where a single-wall metal pipe is used and has a shape other than round, it shall have an equivalent effective area equal to the effective area of the round pipe for which it is substituted and the minimum internal dimension of the pipe shall be 2 in. (50 mm).
- (3) The vent cap or a roof assembly shall have a venting capacity not less than that of the pipe to which it is attached.

Table 12.8.4.4 Clearances for Connectors

| Appliance | Minimum Distance from Combustible Material | | | |
|----------------------------------------------------------------------------------------|--------------------------------------------|-----------------------------|------------------------|--------------------------------|
| | Listed Type B Gas Vent Material | Listed Type L Vent Material | Single-Wall Metal Pipe | Factory-Built Chimney Sections |
| Listed appliance with draft hoods and appliance listed for use with Type B gas vents | As listed | As listed | 6 in. | As listed |
| Residential boilers and furnaces with listed gas conversion burner and with draft hood | 6 in. | 6 in. | 9 in. | As listed |
| Residential appliances listed for use with Type L vents | Not permitted | As listed | 9 in. | As listed |
| Listed gas-fired toilets | Not permitted | As listed | As listed | As listed |
| Unlisted residential appliances with draft hood | Not permitted | 6 in. | 9 in. | As listed |
| Residential and low-heat appliances other than those above | Not permitted | 9 in. | 18 in. | As listed |
| Medium-heat appliance | Not permitted | Not permitted | 36 in. | As listed |

For SI units, 1 in. = 25.4 mm.

Note: These clearances shall apply unless the installation instructions of a listed appliance or connector specify different clearances, in which case the listed clearances shall apply.

12.8.6 Support of Single-Wall Metal Pipe. All portions of single-wall metal pipe shall be supported for the design and weight of the material employed.

12.8.7 Marking. Single-wall metal pipe shall comply with the marking provisions of 12.7.7.

12.9* Through-the-Wall Vent Termination.

12.9.1 A mechanical draft venting system shall terminate at least 3 ft (0.9 m) above any forced air inlet located within 10 ft (3 m).

Exception No. 1: This provision shall not apply to the combustion air intake of a direct vent appliance.

Exception No. 2: This provision shall not apply to the separation of the integral outdoor air inlet and flue gas discharge of listed outdoor appliances.

12.9.2 A mechanical draft venting system of other than direct vent type shall terminate at least 4 ft (1.2 m) below, 4 ft (1.2 m) horizontally from, or 1 ft (300 mm) above any door, operable window, or gravity air inlet into any building. The bottom of the vent terminal shall be located at least 12 in. (300 mm) above finished ground level.

△ 12.9.3 The clearances for through-the-wall direct vent terminals shall be in accordance with Table 12.9.3. The bottom of the vent terminal and the air intake shall be located not less than 12 in. (300 mm) above finished ground level.

N Table 12.9.3 Through-the-Wall Direct Vent Termination Clearances.

| Direct Vent Appliance Input Rating: | Through the Wall Vent Terminal Clearance from any Air Opening into a Building: |
|-------------------------------------------------------------------------------|--------------------------------------------------------------------------------------------------------------------------|
| 10,000 Btu/hr (3kW) and less | 6 in. (150 mm) |
| Greater than 10,000 Btu/hr (3kW) and not exceeding 50,000 Btu/hr (14.7kW) | 9 in. (230 mm) |
| Greater than 50,000 Btu/hr (14.7kW) and not exceeding 150,000 Btu/hr (29.4kW) | 12 in. (300 mm) |
| > 150,000 Btu/hr (29.4kW) | In accordance with the appliance manufacturer's instructions and in no case less than the clearances specified in 12.9.2 |

12.9.4 Through-the-wall vents for Category II and Category IV appliances and noncategorized condensing appliances shall not terminate over public walkways or over an area where condensate or vapor could create a nuisance or hazard or could be detrimental to the operation of regulators, relief valves, or other equipment. Where local experience indicates that condensate is a problem with Category I and Category III appliances, this provision shall also apply. Drains for condensate shall be installed in accordance with the appliance and vent manufacturers' installation instructions.

12.9.5 Where vents, including those for direct-vent appliances or combustion air intake pipes, penetrate outside walls of buildings, the annular spaces around such penetrations shall be permanently sealed using approved materials to prevent entry of combustion products into the building.

12.9.6 Vent systems for Category IV appliances that terminate through an outside wall of a building and discharge flue gases perpendicular to the adjacent wall shall be located not less than 10 ft (3 m) horizontally from an operable opening in an adjacent building.

Exception: This shall not apply to vent terminals that are 2 ft (0.6 m) or more above or 25 ft (7.6 m) or more below operable openings.

12.10 Condensation Drain.

12.10.1 Provision shall be made to collect and dispose of condensate from venting systems serving Category II and Category IV appliances and noncategorized condensing appliances in accordance with 12.9.4.

12.10.2 Where local experience indicates that condensation is a problem, provision shall be made to drain off and dispose of condensate from venting systems serving Category I and Category III appliances in accordance with 12.9.4.

12.11 Vent Connectors for Category I Appliances.

12.11.1 Where Required. A vent connector shall be used to connect an appliance to a gas vent, chimney, or single-wall metal pipe, except where the gas vent, chimney, or single-wall metal pipe is directly connected to the appliance.

12.11.2 Materials.

12.11.2.1 A vent connector shall be made of noncombustible, corrosion-resistant material capable of withstanding the vent gas temperature produced by the appliance and of sufficient thickness to withstand physical damage.

12.11.2.2 Where the vent connector used for an appliance having a draft hood or a Category I appliance is located in or passes through an unconditioned area, attic, or crawl space, that portion of the vent connector shall be listed Type B, Type L, or listed vent material having equivalent insulation qualities.

Exception: Single-wall metal pipe located within the exterior walls of the building and located in an unconditioned area other than an attic or a crawl space having a local 99 percent winter design temperature of 5°F (-15°C) or higher.

12.11.2.3 Vent connectors for residential-type appliances shall comply with the following:

(1) Vent connectors for listed appliances having draft hoods, appliances having draft hoods and equipped with listed conversion burners, and Category I appliances that are not installed in attics, crawl spaces, or other unconditioned areas shall be one of the following:

- (a) Type B or Type L vent material
- (b) Galvanized sheet steel not less than 0.018 in. (0.46 mm) thick
- (c) Aluminum (1100 or 3003 alloy or equivalent) sheet not less than 0.027 in. (0.69 mm) thick
- (d) Stainless steel sheet not less than 0.012 in. (0.31 mm) thick
- (e) Smooth interior wall metal pipe having resistance to heat and corrosion equal to or greater than that of 12.11.2.3(1)(b), (c), or (d)

- (f) A listed vent connector
 (2) Vent connectors shall not be covered with insulation.

Exception: Listed insulated vent connectors shall be installed in accordance with the manufacturer's installation instructions.

12.11.2.4 A vent connector for a nonresidential low-heat appliance shall be a factory-built chimney section or steel pipe having resistance to heat and corrosion equivalent to that for the appropriate galvanized pipe as specified in Table 12.11.2.4. Factory-built chimney sections shall be joined together in accordance with the chimney manufacturer's instructions.

Table 12.11.2.4 Minimum Thickness for Galvanized Steel Vent Connectors for Low-Heat Appliances

| Diameter of Connector (in.) | Minimum Thickness (in.) |
|-----------------------------|-------------------------|
| Less than 6 | 0.019 |
| 6 to less than 10 | 0.023 |
| 10 to 12 inclusive | 0.029 |
| 14 to 16 inclusive | 0.034 |
| Over 16 | 0.056 |

For SI units, 1 in. = 25.4 mm, 1 in.² = 645 mm².

12.11.2.5 Vent connectors for medium-heat appliances shall be constructed of factory-built, medium-heat chimney sections or steel of a thickness not less than that specified in Table 12.11.2.5 and shall comply with the following:

- A steel vent connector for an appliance with a vent gas temperature in excess of 1000°F (538°C) measured at the entrance to the connector shall be lined with medium-duty fire brick or the equivalent.
- The lining shall be at least 2½ in. (64 mm) thick for a vent connector having a diameter or greatest cross-sectional dimension of 18 in. (460 mm) or less.
- The lining shall be at least 4½ in. (110 mm) thick laid on the 4½ in. (110 mm) bed for a vent connector having a diameter or greatest cross-sectional dimension greater than 18 in. (460 mm).
- Factory-built chimney sections, if employed, shall be joined together in accordance with the chimney manufacturer's instructions.

12.11.3* Size of Vent Connector.

12.11.3.1 A vent connector for an appliance with a single draft hood or for a Category I fan-assisted combustion system appli-

Table 12.11.2.5 Minimum Thickness for Steel Vent Connectors for Medium-Heat Appliances

| Vent Connector Size | | Minimum Thickness (in.) |
|---------------------|--------------------------|-------------------------|
| Diameter (in.) | Area (in. ²) | |
| Up to 14 | Up to 154 | 0.053 |
| Over 14 to 16 | 154 to 201 | 0.067 |
| Over 16 to 18 | 201 to 254 | 0.093 |
| Over 18 | Larger than 254 | 0.123 |

For SI units, 1 in. = 25.4 mm, 1 in.² = 645 mm².

ance shall be sized and installed in accordance with Chapter 13 or other approved engineering methods.

12.11.3.2 For a single appliance having more than one draft hood outlet or flue collar, the manifold shall be constructed according to the instructions of the appliance manufacturer. Where there are no instructions, the manifold shall be designed and constructed in accordance with approved engineering practices. As an alternative method, the effective area of the manifold shall equal the combined area of the flue collars or draft hood outlets, and the vent connectors shall have a minimum 1 ft (0.3 m) rise.

12.11.3.3 Where two or more appliances are connected to a common vent or chimney, each vent connector shall be sized in accordance with Chapter 13 or other approved engineering methods.

12.11.3.4 As an alternative method applicable only where all of the appliances are draft hood-equipped, each vent connector shall have an effective area not less than the area of the draft hood outlet of the appliance to which it is connected.

12.11.3.5 Where two or more appliances are vented through a common vent connector or vent manifold, the common vent connector or vent manifold shall be located at the highest level consistent with available headroom and clearance to combustible material and sized in accordance with Chapter 13 or other approved engineering methods.

12.11.3.6 As an alternative method applicable only where there are two draft hood-equipped appliances, the effective area of the common vent connector or vent manifold and all junction fittings shall be not less than the area of the larger vent connector plus 50 percent of the area of the smaller flue collar outlet.

12.11.3.7 Where the size of a vent connector is increased to overcome installation limitations and obtain connector capacity equal to the appliance input, the size increase shall be made at the appliance draft hood outlet.

12.11.4 Two or More Appliances Connected to a Single Vent.

12.11.4.1 Where two or more openings are provided into one chimney flue or vent, either of the following shall apply:

- The openings shall be at different levels.
- The connectors shall be attached to the vertical portion of the chimney or vent at an angle of 45 degrees or less relative to the vertical.

12.11.4.2 Where two or more vent connectors enter a common vent, chimney flue, or single-wall metal pipe, the smaller connector shall enter at the highest level consistent with the available headroom or clearance to combustible material.

12.11.4.3 Vent connectors serving Category I appliances shall not be connected to any portion of a mechanical draft system operating under positive static pressure, such as those serving Category III or Category IV appliances.

12.11.5 Clearance. Minimum clearances from vent connectors to combustible material shall be in accordance with Table 12.8.4.4.

Exception: The clearance between a vent connector and combustible material shall be permitted to be reduced where the combustible material is protected as specified for vent connectors in Table 10.2.3.

12.11.6 Joints. Joints between sections of connector piping and connections to flue collars or draft hood outlets shall be fastened in accordance with one of the following methods:

- (1) Sheet metal screws
- (2) Vent connectors of listed vent material assembled and connected to flue collars or draft hood outlets in accordance with the manufacturers' instructions
- (3) Other approved means

12.11.7 Slope. A vent connector shall be installed without any dips or sags and shall slope upward toward the vent or chimney at least $\frac{1}{4}$ in./ft (20 mm/m).

Exception: Vent connectors attached to a mechanical draft system installed in accordance with appliance and the draft system manufacturers' instructions.

12.11.8* Length of Vent Connector.

12.11.8.1 The maximum horizontal length of a single-wall connector shall be 75 percent of the height of the chimney or vent, except for engineered systems.

12.11.8.2 The maximum horizontal length of a Type B double-wall connector shall be 100 percent of the height of the chimney or vent, except for engineered systems. The maximum length of an individual connector for a chimney or vent system serving multiple appliances, from the appliance outlet to the junction with the common vent or another connector, shall be 100 percent of the height of the chimney or vent.

12.11.9 Support. A vent connector shall be supported for the design and weight of the material employed to maintain clearances and prevent physical damage and separation of joints.

12.11.10 Chimney Connection. Where entering a flue in a masonry or metal chimney, the vent connector shall be installed above the extreme bottom to avoid stoppage. Where a thimble or slip joint is used to facilitate removal of the connector, the connector shall be firmly attached to or inserted into the thimble or slip joint to prevent the connector from falling out. Means shall be employed to prevent the connector from entering so far as to restrict the space between its end and the opposite wall of the chimney flue.

12.11.11 Inspection. The entire length of a vent connector shall be readily accessible for inspection, cleaning, and replacement.

12.11.12 Fireplaces. A vent connector shall not be connected to a chimney flue serving a fireplace unless the fireplace flue opening is permanently sealed.

12.11.13 Passage Through Ceilings, Floors, or Walls.

12.11.13.1 Single-wall metal pipe connectors shall not pass through any wall, floor, or ceiling except as permitted by 12.8.4.2 and 12.8.4.6.

12.11.13.2 Vent connectors for medium-heat appliances shall not pass through walls or partitions constructed of combustible material.

12.12 Vent Connectors for Category II, Category III, and Category IV Appliances. The vent connectors for Category II, Category III, and Category IV appliances shall be in accordance with Section 12.5.

12.13 Draft Hoods and Draft Controls.

12.13.1 Appliances Requiring Draft Hoods. Vented appliances shall be installed with draft hoods.

Exception: Dual oven-type combination ranges; direct vent appliances; fan-assisted combustion system appliances; appliances requiring chimney draft for operation; single-firebox boilers equipped with conversion burners with inputs greater than 400,000 Btu/hr (117 kW); appliances equipped with blast, power, or pressure burners that are not listed for use with draft hoods; and appliances designed for forced venting.

12.13.2 Installation. A draft hood supplied with or forming a part of a listed vented appliance shall be installed without alteration, exactly as furnished and specified by the appliance manufacturer.

12.13.2.1 If a draft hood is not supplied by the appliance manufacturer where one is required, a draft hood shall be installed, be of a listed or approved type, and, in the absence of other instructions, be of the same size as the appliance flue collar. Where a draft hood is required with a conversion burner, it shall be of a listed or approved type.

12.13.2.2 Where a draft hood of special design is needed or preferable, the installation shall be approved and in accordance with the recommendations of the appliance manufacturer.

12.13.3 Draft Control Devices. Where a draft control device is part of the appliance or is supplied by the appliance manufacturer, it shall be installed in accordance with the manufacturer's instructions. In the absence of manufacturer's instructions, the device shall be attached to the flue collar of the appliance or as near to the appliance as practical.

12.13.4* Additional Devices. Appliances requiring controlled chimney draft shall be permitted to be equipped with listed double-acting barometric draft regulators installed and adjusted in accordance with the manufacturer's instructions.

12.13.5 Location. Draft hoods and barometric draft regulators shall be installed in the same room or enclosure as the appliance in such a manner as to prevent any difference in pressure between the hood or regulator and the combustion air supply.

12.13.6 Positioning. Draft hoods and draft regulators shall be installed in the position for which they were designed with reference to the horizontal and vertical planes and shall be located so that the relief opening is not obstructed by any part of the appliance or adjacent construction. The appliance and its draft hood shall be located so that the relief opening is accessible for checking vent operation.

12.13.7 Clearance. A draft hood shall be located so that its relief opening is not less than 6 in. (150 mm) from any surface except that of the appliance it serves and the venting system to which the draft hood is connected. Where a greater or lesser clearance is indicated on the appliance label, the clearance shall not be less than that specified on the label. Such clearances shall not be reduced.

12.14 Manually Operated Dampers. A manually operated damper shall not be placed in any appliance vent connector. Fixed baffles shall not be classified as manually operated dampers.

12.15 Automatically Operated Vent Dampers. An automatically operated vent damper shall be of a listed type.

12.16 Obstructions. Devices that retard the flow of vent gases shall not be installed in a vent connector, chimney, or vent. The following shall not be considered as obstructions:

- (1) Draft regulators and safety controls specifically listed for installation in venting systems and installed in accordance with the manufacturer's installation instructions
- (2) Approved draft regulators and safety controls designed and installed in accordance with approved engineering methods
- (3) Listed heat reclaimers and automatically operated vent dampers installed in accordance with the manufacturers' installation instructions
- (4) Vent dampers serving listed appliances installed in accordance with 13.1.1 or 13.2.1 or other approved engineering methods
- (5) Approved economizers, heat reclaimers, and recuperators installed in venting systems of appliances not required to be equipped with draft hoods, provided the appliance manufacturer's instructions cover the installation of such a device in the venting system and performance in accordance with Section 12.1 and 12.4.1 is obtained

Chapter 13 Sizing of Category I Venting Systems

△ 13.1 Additional Requirements to Single Appliance Vent. This section shall apply where Table 13.1(a) through Table 13.1(f) are used to size single appliance venting systems. Subsections 13.1.1 through 13.1.18 apply to Table 13.1(a) through Table 13.1(f).

13.1.1 Obstructions and Vent Dampers. Venting Table 13.1(a) through Table 13.1(f) shall not be used where obstructions are installed in the venting system. The installation of vents serving listed appliances with vent dampers shall be in accordance with the appliance manufacturer's instructions or in accordance with the following:

- (1) The maximum capacity of the vent system shall be determined using the "NAT Max" column.
- (2) The minimum capacity shall be determined as though the appliance were a fan-assisted appliance, using the "FAN Min" column to determine the minimum capacity of the vent system. Where the corresponding "Fan Min" is "NA," the vent configuration shall not be permitted and an alternative venting configuration shall be utilized.

13.1.2 Vent Downsizing. Where the vent size determined from the tables is smaller than the appliance draft hood outlet or flue collar, the use of the smaller size shall be permitted, provided that the installation complies with all of the following requirements:

- (1) The total vent height (H) is at least 10 ft (3 m).
- (2) Vents for appliance draft hood outlets or flue collars 12 in. (300 mm) in diameter or smaller are not reduced more than one table size.
- (3) Vents for appliance draft hood outlets or flue collars larger than 12 in. (300 mm) in diameter are not reduced more than two table sizes.
- (4) The maximum capacity listed in the tables for a fan-assisted appliance is reduced by 10 percent ($0.90 \times$ maximum table capacity).

- (5) The draft hood outlet is greater than 4 in. (100 mm) in diameter. A 3 in. (80 mm) diameter vent shall not be connected to a 4 in. (100 mm) diameter draft hood outlet. This provision shall not apply to fan-assisted appliances.

13.1.3 Elbows. Single-appliance venting configurations with zero (0) lateral lengths in Table 13.1(a), Table 13.1(b), and Table 13.1(e) shall not have elbows in the venting system. Single-appliance venting with lateral lengths include two 90 degree elbows. For each additional elbow up to and including 45 degrees, the maximum capacity listed in the venting tables shall be reduced by 5 percent. For each additional elbow greater than 45 degrees up to and including 90 degrees, the maximum capacity listed in the venting tables shall be reduced by 10 percent. Where multiple offsets occur in a vent, the total lateral length of all offsets combined shall not exceed that specified in Table 13.1(a) through Table 13.1(e).

13.1.4 Zero Lateral. Zero (0) lateral (L) shall apply only to a straight vertical vent attached to a top outlet draft hood or flue collar.

13.1.5 High-Altitude Installations. Sea level input ratings shall be used when determining maximum capacity for high-altitude installation. Actual input (derated for altitude) shall be used for determining minimum capacity for high-altitude installation.

13.1.6 Two-Stage/Modulating Appliances. For appliances with more than one input rate, the minimum vent capacity (FAN Min) determined from the Chapter 13 tables shall be less than the lowest appliance input rating, and the maximum vent capacity (FAN Max/NAT Max) determined from the tables shall be greater than the highest appliance rating input.

13.1.7* Corrugated Chimney Liners. Listed corrugated metallic chimney liner systems in masonry chimneys shall be sized by using Table 13.1(a) or Table 13.1(b) for Type B vents, with the maximum capacity reduced by 20 percent ($0.80 \times$ maximum capacity) and the minimum capacity as shown in Table 13.1(a) or Table 13.1(b). Corrugated metallic liner systems installed with bends or offsets shall have their maximum capacity further reduced in accordance with 13.1.3. The 20 percent reduction for corrugated metallic chimney liner systems includes an allowance for one long radius 90-degree turn at the bottom of the liner.

13.1.8 Connection to Chimney Liners. Connections between chimney liners and listed double-wall connectors shall be made with listed adapters designed for such purpose.

13.1.9 Vertical Vent Upsizing/7 × Rule. Where the vertical vent has a larger diameter than the vent connector, the vertical vent diameter shall be used to determine the minimum vent capacity, and the connector diameter shall be used to determine the maximum vent capacity. The flow area of the vertical vent shall not exceed seven times the flow area of the listed appliance categorized vent area, flue collar area, or draft hood outlet area unless designed in accordance with approved engineering methods.

13.1.10 Draft Hood Conversion Accessories. Draft hood conversion accessories for use with masonry chimneys venting listed Category I fan-assisted appliances shall be listed and installed in accordance with the listed accessory manufacturers' installation instructions.

Table 13.1(a) Type B Double-Wall Gas Vent

| | | Number of Appliances: Single | | | | | | | | | | | | | | | | | | | | | | | |
|----------------------------|-----------------------------|-------------------------------------------------------|-----|-----|-----|-----|-----|-----|-----|-----|-----|-----|-----|-----|-----|-----|-----|------|-----|-----|------|------|-----|-----|-----|
| | | Appliance Type: Category I | | | | | | | | | | | | | | | | | | | | | | | |
| | | Appliance Vent Connection: Connected Directly to Vent | | | | | | | | | | | | | | | | | | | | | | | |
| | | Vent Diameter — <i>D</i> (in.) | | | | | | | | | | | | | | | | | | | | | | | |
| | | 3 | | | 4 | | | 5 | | | 6 | | | 7 | | | 8 | | | 9 | | | | | |
| Height <i>H</i> (ft) | Lateral <i>L</i> (ft) | Appliance Input Rating in Thousands of Btu per Hour | | | | | | | | | | | | | | | | | | | | | | | |
| | | FAN | | | NAT | | | FAN | | | NAT | | | FAN | | | NAT | | | FAN | | | NAT | | |
| | | Min | Max | Max | Min | Max | Max | Min | Max | Max | Min | Max | Max | Min | Max | Max | Min | Max | Max | Min | Max | Max | Min | Max | Max |
| 6 | 0 | 0 | 78 | 46 | 0 | 152 | 86 | 0 | 251 | 141 | 0 | 375 | 205 | 0 | 524 | 285 | 0 | 698 | 370 | 0 | 897 | 470 | | | |
| | 2 | 13 | 51 | 36 | 18 | 97 | 67 | 27 | 157 | 105 | 32 | 232 | 157 | 44 | 321 | 217 | 53 | 425 | 285 | 63 | 543 | 370 | | | |
| | 4 | 21 | 49 | 34 | 30 | 94 | 64 | 39 | 153 | 103 | 50 | 227 | 153 | 66 | 316 | 211 | 79 | 419 | 279 | 93 | 536 | 362 | | | |
| | 6 | 25 | 46 | 32 | 36 | 91 | 61 | 47 | 149 | 100 | 59 | 223 | 149 | 78 | 310 | 205 | 93 | 413 | 273 | 110 | 530 | 354 | | | |
| 8 | 0 | 0 | 84 | 50 | 0 | 165 | 94 | 0 | 276 | 155 | 0 | 415 | 235 | 0 | 583 | 320 | 0 | 780 | 415 | 0 | 1006 | 537 | | | |
| | 2 | 12 | 57 | 40 | 16 | 109 | 75 | 25 | 178 | 120 | 28 | 263 | 180 | 42 | 365 | 247 | 50 | 483 | 322 | 60 | 619 | 418 | | | |
| | 5 | 23 | 53 | 38 | 32 | 103 | 71 | 42 | 171 | 115 | 53 | 255 | 173 | 70 | 356 | 237 | 83 | 473 | 313 | 99 | 607 | 407 | | | |
| | 8 | 28 | 49 | 35 | 39 | 98 | 66 | 51 | 164 | 109 | 64 | 247 | 165 | 84 | 347 | 227 | 99 | 463 | 303 | 117 | 596 | 396 | | | |
| 10 | 0 | 0 | 88 | 53 | 0 | 175 | 100 | 0 | 295 | 166 | 0 | 447 | 255 | 0 | 631 | 345 | 0 | 847 | 450 | 0 | 1096 | 585 | | | |
| | 2 | 12 | 61 | 42 | 17 | 118 | 81 | 23 | 194 | 129 | 26 | 289 | 195 | 40 | 402 | 273 | 48 | 533 | 355 | 57 | 684 | 457 | | | |
| | 5 | 23 | 57 | 40 | 32 | 113 | 77 | 41 | 187 | 124 | 52 | 280 | 188 | 68 | 392 | 263 | 81 | 522 | 346 | 95 | 671 | 446 | | | |
| | 10 | 30 | 51 | 36 | 41 | 104 | 70 | 54 | 176 | 115 | 67 | 267 | 175 | 88 | 376 | 245 | 104 | 504 | 330 | 122 | 651 | 427 | | | |
| 15 | 0 | 0 | 94 | 58 | 0 | 191 | 112 | 0 | 327 | 187 | 0 | 502 | 285 | 0 | 716 | 390 | 0 | 970 | 525 | 0 | 1263 | 682 | | | |
| | 2 | 11 | 69 | 48 | 15 | 136 | 93 | 20 | 226 | 150 | 22 | 339 | 225 | 38 | 475 | 316 | 45 | 633 | 414 | 53 | 815 | 544 | | | |
| | 5 | 22 | 65 | 45 | 30 | 130 | 87 | 39 | 219 | 142 | 49 | 330 | 217 | 64 | 463 | 300 | 76 | 620 | 403 | 90 | 800 | 529 | | | |
| | 10 | 29 | 59 | 41 | 40 | 121 | 82 | 51 | 206 | 135 | 64 | 315 | 208 | 84 | 445 | 288 | 99 | 600 | 386 | 116 | 777 | 507 | | | |
| | 15 | 35 | 53 | 37 | 48 | 112 | 76 | 61 | 195 | 128 | 76 | 301 | 198 | 98 | 429 | 275 | 115 | 580 | 373 | 134 | 755 | 491 | | | |
| 20 | 0 | 0 | 97 | 61 | 0 | 202 | 119 | 0 | 349 | 202 | 0 | 540 | 307 | 0 | 776 | 430 | 0 | 1057 | 575 | 0 | 1384 | 752 | | | |
| | 2 | 10 | 75 | 51 | 14 | 149 | 100 | 18 | 250 | 166 | 20 | 377 | 249 | 33 | 531 | 346 | 41 | 711 | 470 | 50 | 917 | 612 | | | |
| | 5 | 21 | 71 | 48 | 29 | 143 | 96 | 38 | 242 | 160 | 47 | 367 | 241 | 62 | 519 | 337 | 73 | 697 | 460 | 86 | 902 | 599 | | | |
| | 10 | 28 | 64 | 44 | 38 | 133 | 89 | 50 | 229 | 150 | 62 | 351 | 228 | 81 | 499 | 321 | 95 | 675 | 443 | 112 | 877 | 576 | | | |
| | 15 | 34 | 58 | 40 | 46 | 124 | 84 | 59 | 217 | 142 | 73 | 337 | 217 | 94 | 481 | 308 | 111 | 654 | 427 | 129 | 853 | 557 | | | |
| | 20 | 48 | 52 | 35 | 55 | 116 | 78 | 69 | 206 | 134 | 84 | 322 | 206 | 107 | 464 | 295 | 125 | 634 | 410 | 145 | 830 | 537 | | | |
| 30 | 0 | 0 | 100 | 64 | 0 | 213 | 128 | 0 | 374 | 220 | 0 | 587 | 336 | 0 | 853 | 475 | 0 | 1173 | 650 | 0 | 1548 | 855 | | | |
| | 2 | 9 | 81 | 56 | 13 | 166 | 112 | 14 | 283 | 185 | 18 | 432 | 280 | 27 | 613 | 394 | 33 | 826 | 535 | 42 | 1072 | 700 | | | |
| | 5 | 21 | 77 | 54 | 28 | 160 | 108 | 36 | 275 | 176 | 45 | 421 | 273 | 58 | 600 | 385 | 69 | 811 | 524 | 82 | 1055 | 688 | | | |
| | 10 | 27 | 70 | 50 | 37 | 150 | 102 | 48 | 262 | 171 | 59 | 405 | 261 | 77 | 580 | 371 | 91 | 788 | 507 | 107 | 1028 | 668 | | | |
| | 15 | 33 | 64 | NA | 44 | 141 | 96 | 57 | 249 | 163 | 70 | 389 | 249 | 90 | 560 | 357 | 105 | 765 | 490 | 124 | 1002 | 648 | | | |
| | 20 | 56 | 58 | NA | 53 | 132 | 90 | 66 | 237 | 154 | 80 | 374 | 237 | 102 | 542 | 343 | 119 | 743 | 473 | 139 | 977 | 628 | | | |
| | 30 | NA | NA | NA | 73 | 113 | NA | 88 | 214 | NA | 104 | 346 | 219 | 131 | 507 | 321 | 149 | 702 | 444 | 171 | 929 | 594 | | | |
| 50 | 0 | 0 | 101 | 67 | 0 | 216 | 134 | 0 | 397 | 232 | 0 | 633 | 363 | 0 | 932 | 518 | 0 | 1297 | 708 | 0 | 1730 | 952 | | | |
| | 2 | 8 | 86 | 61 | 11 | 183 | 122 | 14 | 320 | 206 | 15 | 497 | 314 | 22 | 715 | 445 | 26 | 975 | 615 | 33 | 1276 | 813 | | | |
| | 5 | 20 | 82 | NA | 27 | 177 | 119 | 35 | 312 | 200 | 43 | 487 | 308 | 55 | 702 | 438 | 65 | 960 | 605 | 77 | 1259 | 798 | | | |
| | 10 | 26 | 76 | NA | 35 | 168 | 114 | 45 | 299 | 190 | 56 | 471 | 298 | 73 | 681 | 426 | 86 | 935 | 589 | 101 | 1230 | 773 | | | |
| | 15 | 59 | 70 | NA | 42 | 158 | NA | 54 | 287 | 180 | 66 | 455 | 288 | 85 | 662 | 413 | 100 | 911 | 572 | 117 | 1203 | 747 | | | |
| | 20 | NA | NA | NA | 50 | 149 | NA | 63 | 275 | 169 | 76 | 440 | 278 | 97 | 642 | 401 | 113 | 888 | 556 | 131 | 1176 | 722 | | | |
| | 30 | NA | NA | NA | 69 | 131 | NA | 84 | 250 | NA | 99 | 410 | 259 | 123 | 605 | 376 | 141 | 844 | 522 | 161 | 1125 | 670 | | | |
| 100 | 0 | NA | NA | NA | 0 | 218 | NA | 0 | 407 | NA | 0 | 665 | 400 | 0 | 997 | 560 | 0 | 1411 | 770 | 0 | 1908 | 1040 | | | |
| | 2 | NA | NA | NA | 10 | 194 | NA | 12 | 354 | NA | 13 | 566 | 375 | 18 | 831 | 510 | 21 | 1155 | 700 | 25 | 1536 | 935 | | | |
| | 5 | NA | NA | NA | 26 | 189 | NA | 33 | 347 | NA | 40 | 557 | 369 | 52 | 820 | 504 | 60 | 1141 | 692 | 71 | 1519 | 926 | | | |
| | 10 | NA | NA | NA | 33 | 182 | NA | 43 | 335 | NA | 53 | 542 | 361 | 68 | 801 | 493 | 80 | 1118 | 679 | 94 | 1492 | 910 | | | |
| | 15 | NA | NA | NA | 40 | 174 | NA | 50 | 321 | NA | 62 | 528 | 353 | 80 | 782 | 482 | 93 | 1095 | 666 | 109 | 1465 | 895 | | | |
| | 20 | NA | NA | NA | 47 | 166 | NA | 59 | 311 | NA | 71 | 513 | 344 | 90 | 763 | 471 | 105 | 1073 | 653 | 122 | 1438 | 880 | | | |
| | 30 | NA | NA | NA | NA | NA | NA | 78 | 290 | NA | 92 | 483 | NA | 115 | 726 | 449 | 131 | 1029 | 627 | 149 | 1387 | 849 | | | |
| | 50 | NA | NA | NA | NA | NA | NA | NA | NA | NA | 147 | 428 | NA | 180 | 651 | 405 | 197 | 944 | 575 | 217 | 1288 | 787 | | | |

(continues)

Table 13.1(a) Continued

| | | Number of Appliances: Single | | | | | | | | | | | | | | | | | | | | | | | |
|---------------------|----------------------|-------------------------------------------------------|------|------|-----|------|------|-----|------|------|-----|------|------|-----|--------|------|-----|--------|------|-----|--------|------|-----|--------|--------|
| | | Appliance Type: Category I | | | | | | | | | | | | | | | | | | | | | | | |
| | | Appliance Vent Connection: Connected Directly to Vent | | | | | | | | | | | | | | | | | | | | | | | |
| | | Vent Diameter—D (in.) | | | | | | | | | | | | | | | | | | | | | | | |
| | | 10 | | | 12 | | | 14 | | | 16 | | | 18 | | | 20 | | | 22 | | | 24 | | |
| | | Appliance Input Rating in Thousands of Btu per Hour | | | | | | | | | | | | | | | | | | | | | | | |
| Height H (ft) | Lateral L (ft) | FAN | | NAT | FAN | | NAT | FAN | | NAT | FAN | | NAT | FAN | | NAT | FAN | | NAT | FAN | | NAT | FAN | | NAT |
| | | Min | Max | Max | Min | Max | Max | Min | Max | Max | Min | Max | Max | Min | Max | Max | Min | Max | Max | Min | Max | Max | Min | Max | Max |
| 6 | 0 | 0 | 1121 | 570 | 0 | 1645 | 850 | 0 | 2267 | 1170 | 0 | 2983 | 1530 | 0 | 3802 | 1960 | 0 | 4721 | 2430 | 0 | 5737 | 2950 | 0 | 6853 | 3520 |
| | 2 | 75 | 675 | 455 | 103 | 982 | 650 | 138 | 1346 | 890 | 178 | 1769 | 1170 | 225 | 2250 | 1480 | 296 | 2782 | 1850 | 360 | 3377 | 2220 | 426 | 4030 | 2670 |
| | 4 | 110 | 668 | 445 | 147 | 975 | 640 | 191 | 1338 | 880 | 242 | 1761 | 1160 | 300 | 2242 | 1475 | 390 | 2774 | 1835 | 469 | 3370 | 2215 | 555 | 4023 | 2660 |
| | 6 | 128 | 661 | 435 | 171 | 967 | 630 | 219 | 1330 | 870 | 276 | 1753 | 1150 | 341 | 2235 | 1470 | 437 | 2767 | 1820 | 523 | 3363 | 2210 | 618 | 4017 | 2650 |
| 8 | 0 | 0 | 1261 | 660 | 0 | 1858 | 970 | 0 | 2571 | 1320 | 0 | 3399 | 1740 | 0 | 4333 | 2220 | 0 | 5387 | 2750 | 0 | 6555 | 3360 | 0 | 7838 | 4010 |
| | 2 | 71 | 770 | 515 | 98 | 1124 | 745 | 130 | 1543 | 1020 | 168 | 2030 | 1340 | 212 | 2584 | 1700 | 278 | 3196 | 2110 | 336 | 3882 | 2560 | 401 | 4634 | 3050 |
| | 5 | 115 | 758 | 503 | 154 | 1110 | 733 | 199 | 1528 | 1010 | 251 | 2013 | 1330 | 311 | 2563 | 1685 | 398 | 3180 | 2090 | 476 | 3863 | 2545 | 562 | 4612 | 3040 |
| | 8 | 137 | 746 | 490 | 180 | 1097 | 720 | 231 | 1514 | 1000 | 289 | 2000 | 1320 | 354 | 2552 | 1670 | 450 | 3163 | 2070 | 537 | 3850 | 2530 | 630 | 4602 | 3030 |
| 10 | 0 | 0 | 1377 | 720 | 0 | 2036 | 1060 | 0 | 2825 | 1450 | 0 | 3742 | 1925 | 0 | 4782 | 2450 | 0 | 5955 | 3050 | 0 | 7254 | 3710 | 0 | 8682 | 4450 |
| | 2 | 68 | 852 | 560 | 93 | 1244 | 850 | 124 | 1713 | 1130 | 161 | 2256 | 1480 | 202 | 2868 | 1890 | 264 | 3556 | 2340 | 319 | 4322 | 2840 | 378 | 5153 | 3390 |
| | 5 | 112 | 839 | 547 | 149 | 1229 | 829 | 192 | 1696 | 1105 | 243 | 2238 | 1461 | 300 | 2849 | 1871 | 382 | 3536 | 2318 | 458 | 4301 | 2818 | 540 | 5132 | 3371 |
| | 10 | 142 | 817 | 525 | 187 | 1204 | 795 | 238 | 1669 | 1080 | 298 | 2209 | 1430 | 364 | 2818 | 1840 | 459 | 3504 | 2280 | 546 | 4268 | 2780 | 641 | 5099 | 3340 |
| 15 | 0 | 0 | 1596 | 840 | 0 | 2380 | 1240 | 0 | 3323 | 1720 | 0 | 4423 | 2270 | 0 | 5678 | 2900 | 0 | 7099 | 3620 | 0 | 8665 | 4410 | 0 | 10,393 | 5300 |
| | 2 | 63 | 1019 | 675 | 86 | 1495 | 985 | 114 | 2062 | 1350 | 147 | 2719 | 1770 | 186 | 3467 | 2260 | 239 | 4304 | 2800 | 290 | 5232 | 3410 | 346 | 6251 | 4080 |
| | 5 | 105 | 1003 | 660 | 140 | 1476 | 967 | 182 | 2041 | 1327 | 229 | 2696 | 1748 | 283 | 3442 | 2235 | 355 | 4278 | 2777 | 426 | 5204 | 3385 | 501 | 6222 | 4057 |
| | 10 | 135 | 977 | 635 | 177 | 1446 | 936 | 227 | 2009 | 1289 | 283 | 2659 | 1712 | 346 | 3402 | 2193 | 432 | 4234 | 2739 | 510 | 5159 | 3343 | 599 | 6175 | 4019 |
| | 15 | 155 | 953 | 610 | 202 | 1418 | 905 | 257 | 1976 | 1250 | 318 | 2623 | 1675 | 385 | 3363 | 2150 | 479 | 4192 | 2700 | 564 | 5115 | 3300 | 665 | 6129 | 3980 |
| 20 | 0 | 0 | 1756 | 930 | 0 | 2637 | 1350 | 0 | 3701 | 1900 | 0 | 4948 | 2520 | 0 | 6376 | 3250 | 0 | 7988 | 4060 | 0 | 9785 | 4980 | 0 | 11,753 | 6000 |
| | 2 | 59 | 1150 | 755 | 81 | 1694 | 1100 | 107 | 2343 | 1520 | 139 | 3097 | 2000 | 175 | 3955 | 2570 | 220 | 4916 | 3200 | 269 | 5983 | 3910 | 321 | 7154 | 4700 |
| | 5 | 101 | 1133 | 738 | 135 | 1674 | 1079 | 174 | 2320 | 1498 | 219 | 3071 | 1978 | 270 | 3926 | 2544 | 337 | 4885 | 3174 | 403 | 5950 | 3880 | 475 | 7119 | 4662 |
| | 10 | 130 | 1105 | 710 | 172 | 1641 | 1045 | 220 | 2282 | 1460 | 273 | 3029 | 1940 | 334 | 3880 | 2500 | 413 | 4835 | 3130 | 489 | 5896 | 3830 | 573 | 7063 | 4600 |
| | 15 | 150 | 1078 | 688 | 195 | 1609 | 1018 | 248 | 2245 | 1425 | 306 | 2988 | 1910 | 372 | 3835 | 2465 | 459 | 4786 | 3090 | 541 | 5844 | 3795 | 631 | 7007 | 4575 |
| | 20 | 167 | 1052 | 665 | 217 | 1578 | 990 | 273 | 2210 | 1390 | 335 | 2948 | 1880 | 404 | 3791 | 2430 | 495 | 4737 | 3050 | 585 | 5792 | 3760 | 689 | 6953 | 4550 |
| 30 | 0 | 0 | 1977 | 1060 | 0 | 3004 | 1550 | 0 | 4252 | 2170 | 0 | 5725 | 2920 | 0 | 7420 | 3770 | 0 | 9341 | 4750 | 0 | 11,483 | 5850 | 0 | 13,848 | 7060 |
| | 2 | 54 | 1351 | 865 | 74 | 2004 | 1310 | 98 | 2786 | 1800 | 127 | 3696 | 2380 | 159 | 4734 | 3050 | 199 | 5900 | 3810 | 241 | 7194 | 4650 | 285 | 8617 | 5600 |
| | 5 | 96 | 1332 | 851 | 127 | 1981 | 1289 | 164 | 2759 | 1775 | 206 | 3666 | 2350 | 252 | 4701 | 3020 | 312 | 5863 | 3783 | 373 | 7155 | 4622 | 439 | 8574 | 5552 |
| | 10 | 125 | 1301 | 829 | 164 | 1944 | 1254 | 209 | 2716 | 1733 | 259 | 3617 | 2300 | 316 | 4647 | 2970 | 386 | 5803 | 3739 | 456 | 7090 | 4574 | 535 | 8505 | 5471 |
| | 15 | 143 | 1272 | 807 | 187 | 1908 | 1220 | 237 | 2674 | 1692 | 292 | 3570 | 2250 | 354 | 4594 | 2920 | 431 | 5744 | 3695 | 507 | 7026 | 4527 | 590 | 8437 | 5391 |
| | 20 | 160 | 1243 | 784 | 207 | 1873 | 1185 | 260 | 2633 | 1650 | 319 | 3523 | 2200 | 384 | 4542 | 2870 | 467 | 5686 | 3650 | 548 | 6964 | 4480 | 639 | 8370 | 5310 |
| | 30 | 195 | 1189 | 745 | 246 | 1807 | 1130 | 305 | 2555 | 1585 | 369 | 3433 | 2130 | 440 | 4442 | 2785 | 540 | 5574 | 3565 | 635 | 6842 | 4375 | 739 | 8239 | 5225 |
| 50 | 0 | 0 | 2231 | 1195 | 0 | 3441 | 1825 | 0 | 4934 | 2550 | 0 | 6711 | 3440 | 0 | 8774 | 4460 | 0 | 11,129 | 5635 | 0 | 13,767 | 6940 | 0 | 16,694 | 8430 |
| | 2 | 41 | 1620 | 1010 | 66 | 2431 | 1513 | 86 | 3409 | 2125 | 113 | 4554 | 2840 | 141 | 5864 | 3670 | 171 | 7339 | 4630 | 209 | 8980 | 5695 | 251 | 10,788 | 6860 |
| | 5 | 90 | 1600 | 996 | 118 | 2406 | 1495 | 151 | 3380 | 2102 | 191 | 4520 | 2813 | 234 | 5826 | 3639 | 283 | 7295 | 4597 | 336 | 8933 | 5654 | 394 | 10,737 | 6818 |
| | 10 | 118 | 1567 | 972 | 154 | 2366 | 1466 | 196 | 3332 | 2064 | 243 | 4464 | 2767 | 295 | 5763 | 3585 | 355 | 7294 | 4542 | 419 | 8855 | 5585 | 491 | 10,652 | 6749 |
| | 15 | 136 | 1536 | 948 | 177 | 2327 | 1437 | 222 | 3285 | 2026 | 274 | 4409 | 2721 | 330 | 5701 | 3534 | 396 | 7155 | 4511 | 465 | 8779 | 5546 | 542 | 10,570 | 6710 |
| | 20 | 151 | 1505 | 924 | 195 | 2288 | 1408 | 244 | 3239 | 1987 | 300 | 4356 | 2675 | 361 | 5641 | 3481 | 433 | 7086 | 4479 | 506 | 8704 | 5506 | 586 | 10,488 | 6670 |
| | 30 | 183 | 1446 | 876 | 232 | 2214 | 1349 | 287 | 3150 | 1910 | 347 | 4253 | 2631 | 412 | 5523 | 3431 | 494 | 6953 | 4421 | 577 | 8557 | 5444 | 672 | 10,328 | 6603 |
| 100 | 0 | 0 | 2491 | 1310 | 0 | 3925 | 2050 | 0 | 5729 | 2950 | 0 | 7914 | 4050 | 0 | 10,485 | 5300 | 0 | 13,454 | 6700 | 0 | 16,817 | 8600 | 0 | 20,578 | 10,300 |
| | 2 | 30 | 1975 | 1170 | 44 | 3027 | 1820 | 72 | 4313 | 2550 | 95 | 5834 | 3500 | 120 | 7591 | 4600 | 138 | 9577 | 5800 | 169 | 11,803 | 7200 | 204 | 14,264 | 8800 |
| | 5 | 82 | 1955 | 1159 | 107 | 3002 | 1803 | 136 | 4282 | 2531 | 172 | 5797 | 3475 | 208 | 7548 | 4566 | 245 | 9528 | 5769 | 293 | 11,748 | 7162 | 341 | 14,204 | 8756 |
| | 10 | 108 | 1923 | 1142 | 142 | 2961 | 1775 | 180 | 4231 | 2500 | 223 | 5737 | 3434 | 268 | 7478 | 4509 | 318 | 9447 | 5717 | 374 | 11,658 | 7100 | 436 | 14,105 | 8683 |
| | 15 | 126 | 1892 | 1124 | 163 | 2920 | 1747 | 206 | 4182 | 2469 | 252 | 5678 | 3392 | 304 | 7409 | 4451 | 358 | 9367 | 5665 | 418 | 11,569 | 7037 | 487 | 14,007 | 8610 |
| | 20 | 141 | 1861 | 1107 | 181 | 2880 | 1719 | 226 | 4133 | 2438 | 277 | 5619 | 3351 | 330 | 7341 | 4394 | 387 | 9289 | 5613 | 452 | 11,482 | 6975 | 523 | 13,910 | 8537 |
| | 30 | 170 | 1802 | 1071 | 215 | 2803 | 1663 | 265 | 4037 | 2375 | 319 | 5505 | 3267 | 378 | 7209 | 4279 | 446 | 9136 | 5509 | 514 | 11,310 | 6850 | 592 | 13,720 | 8391 |
| | 50 | 241 | 1688 | 1000 | 292 | 2657 | 1550 | 350 | 3856 | 2250 | 415 | 5289 | 3100 | 486 | 6956 | 4050 | 572 | 8841 | 5300 | 659 | 10,979 | 6600 | 752 | 13,354 | 8100 |

For SI units, 1 in. = 25.4 mm, 1 ft = 0.305 m, 1000 Btu/hr = 0.293 kW, 1 in.² = 645 mm².

NA: Not applicable.

Table 13.1(b) Type B Double-Wall Vent

| | | Number of Appliances: Single | | | | | | | | | | | | | | | | | | | | | | | | | | | | | | | | | | | |
|----------------------------|-----------------------------|--------------------------------------------------------|-----|-----|-----|-----|-----|-----|-----|-----|-----|-----|-----|-----|-----|-----|-----|------|-----|-----|------|------|-----|------|------|------|------|------|-----|-----|-----|-----|-----|-----|-----|-----|--|
| | | Appliance Type: Category I | | | | | | | | | | | | | | | | | | | | | | | | | | | | | | | | | | | |
| | | Appliance Vent Connection: Single-Wall Metal Connector | | | | | | | | | | | | | | | | | | | | | | | | | | | | | | | | | | | |
| | | Vent Diameter — <i>D</i> (in.) | | | | | | | | | | | | | | | | | | | | | | | | | | | | | | | | | | | |
| | | 3 | | | 4 | | | 5 | | | 6 | | | 7 | | | 8 | | | 9 | | | 10 | | | 12 | | | | | | | | | | | |
| Height <i>H</i> (ft) | Lateral <i>L</i> (ft) | Appliance Input Rating in Thousands of Btu per Hour | | | | | | | | | | | | | | | | | | | | | | | | | | | | | | | | | | | |
| | | FAN | | NAT | | FAN | | NAT | | FAN | | NAT | | FAN | | NAT | | FAN | | NAT | | FAN | | NAT | | FAN | | NAT | | FAN | | NAT | | FAN | | NAT | |
| | | Min | Max | Min | Max | Min | Max | Min | Max | Min | Max | Min | Max | Min | Max | Min | Max | Min | Max | Min | Max | Min | Max | Min | Max | Min | Max | Min | Max | Min | Max | Min | Max | Min | Max | | |
| 6 | 0 | 38 | 77 | 45 | 59 | 151 | 85 | 85 | 249 | 140 | 126 | 373 | 204 | 165 | 522 | 284 | 211 | 695 | 369 | 267 | 894 | 469 | 371 | 1118 | 569 | 537 | 1639 | 849 | | | | | | | | | |
| | 2 | 39 | 51 | 36 | 60 | 96 | 66 | 85 | 156 | 104 | 123 | 231 | 156 | 159 | 320 | 213 | 201 | 423 | 284 | 251 | 541 | 368 | 347 | 673 | 453 | 498 | 979 | 648 | | | | | | | | | |
| | 4 | NA | NA | 33 | 74 | 92 | 63 | 102 | 152 | 102 | 146 | 225 | 152 | 187 | 313 | 208 | 237 | 416 | 277 | 295 | 533 | 360 | 409 | 664 | 443 | 584 | 971 | 638 | | | | | | | | | |
| | 6 | NA | NA | 31 | 83 | 89 | 60 | 114 | 147 | 99 | 163 | 220 | 148 | 207 | 307 | 203 | 263 | 409 | 271 | 327 | 526 | 352 | 449 | 656 | 433 | 638 | 962 | 627 | | | | | | | | | |
| 8 | 0 | 37 | 83 | 50 | 58 | 164 | 93 | 83 | 273 | 154 | 123 | 412 | 234 | 161 | 580 | 319 | 206 | 777 | 414 | 258 | 1002 | 536 | 360 | 1257 | 658 | 521 | 1852 | 967 | | | | | | | | | |
| | 2 | 39 | 56 | 39 | 59 | 108 | 75 | 83 | 176 | 119 | 121 | 261 | 179 | 155 | 363 | 246 | 197 | 482 | 321 | 246 | 617 | 417 | 339 | 768 | 513 | 486 | 1120 | 743 | | | | | | | | | |
| | 5 | NA | NA | 37 | 77 | 102 | 69 | 107 | 168 | 114 | 151 | 252 | 171 | 193 | 352 | 235 | 245 | 470 | 311 | 305 | 604 | 404 | 418 | 754 | 500 | 598 | 1104 | 730 | | | | | | | | | |
| | 8 | NA | NA | 33 | 90 | 95 | 64 | 122 | 161 | 107 | 175 | 243 | 163 | 223 | 342 | 225 | 280 | 458 | 300 | 344 | 591 | 392 | 470 | 740 | 486 | 665 | 1089 | 715 | | | | | | | | | |
| 10 | 0 | 37 | 87 | 53 | 57 | 174 | 99 | 82 | 293 | 165 | 120 | 444 | 254 | 158 | 628 | 344 | 202 | 844 | 449 | 253 | 1093 | 584 | 351 | 1373 | 718 | 507 | 2031 | 1057 | | | | | | | | | |
| | 2 | 39 | 61 | 41 | 59 | 117 | 80 | 82 | 193 | 128 | 119 | 287 | 194 | 153 | 400 | 272 | 193 | 531 | 354 | 242 | 681 | 456 | 332 | 849 | 559 | 475 | 1242 | 848 | | | | | | | | | |
| | 5 | 52 | 56 | 39 | 76 | 111 | 76 | 105 | 185 | 122 | 148 | 277 | 186 | 190 | 388 | 261 | 241 | 518 | 344 | 299 | 667 | 443 | 409 | 834 | 544 | 584 | 1224 | 825 | | | | | | | | | |
| | 10 | NA | NA | 34 | 97 | 100 | 68 | 132 | 171 | 112 | 188 | 261 | 171 | 237 | 369 | 241 | 296 | 497 | 325 | 363 | 643 | 423 | 492 | 808 | 520 | 688 | 1194 | 788 | | | | | | | | | |
| 15 | 0 | 36 | 93 | 57 | 56 | 190 | 111 | 80 | 325 | 186 | 116 | 499 | 283 | 153 | 713 | 388 | 195 | 966 | 523 | 244 | 1259 | 681 | 336 | 1591 | 838 | 488 | 2374 | 1237 | | | | | | | | | |
| | 2 | 38 | 69 | 47 | 57 | 136 | 93 | 80 | 225 | 149 | 115 | 337 | 224 | 148 | 473 | 314 | 187 | 631 | 413 | 232 | 812 | 543 | 319 | 1015 | 673 | 457 | 1491 | 983 | | | | | | | | | |
| | 5 | 51 | 63 | 44 | 75 | 128 | 86 | 102 | 216 | 140 | 144 | 326 | 217 | 182 | 459 | 298 | 231 | 616 | 400 | 287 | 795 | 526 | 392 | 997 | 657 | 562 | 1469 | 963 | | | | | | | | | |
| | 10 | NA | NA | 39 | 95 | 116 | 79 | 128 | 201 | 131 | 182 | 308 | 203 | 228 | 438 | 284 | 284 | 592 | 381 | 349 | 768 | 501 | 470 | 966 | 628 | 664 | 1433 | 928 | | | | | | | | | |
| | 15 | NA | NA | NA | NA | NA | 72 | 158 | 186 | 124 | 220 | 290 | 192 | 272 | 418 | 269 | 334 | 568 | 367 | 404 | 742 | 484 | 540 | 937 | 601 | 750 | 1399 | 894 | | | | | | | | | |
| 20 | 0 | 35 | 96 | 60 | 54 | 200 | 118 | 78 | 346 | 201 | 114 | 537 | 306 | 149 | 772 | 428 | 190 | 1053 | 573 | 238 | 1379 | 750 | 326 | 1751 | 927 | 473 | 2631 | 1346 | | | | | | | | | |
| | 2 | 37 | 74 | 50 | 56 | 148 | 99 | 78 | 248 | 165 | 113 | 375 | 244 | 148 | 528 | 344 | 182 | 708 | 468 | 227 | 914 | 611 | 309 | 1146 | 754 | 443 | 1689 | 1098 | | | | | | | | | |
| | 5 | 50 | 68 | 47 | 73 | 140 | 94 | 100 | 239 | 158 | 141 | 363 | 239 | 178 | 514 | 334 | 224 | 692 | 457 | 279 | 896 | 596 | 381 | 1126 | 734 | 547 | 1665 | 1074 | | | | | | | | | |
| | 10 | NA | NA | 41 | 93 | 129 | 86 | 125 | 223 | 146 | 177 | 344 | 224 | 222 | 491 | 316 | 277 | 666 | 437 | 339 | 866 | 570 | 457 | 1092 | 702 | 646 | 1626 | 1037 | | | | | | | | | |
| | 15 | NA | NA | NA | NA | NA | 80 | 155 | 208 | 136 | 216 | 325 | 210 | 264 | 469 | 301 | 325 | 640 | 419 | 393 | 838 | 549 | 526 | 1060 | 677 | 730 | 1587 | 1005 | | | | | | | | | |
| | 20 | NA | NA | NA | NA | NA | NA | 186 | 192 | 126 | 254 | 306 | 196 | 309 | 448 | 285 | 374 | 616 | 400 | 448 | 810 | 526 | 592 | 1028 | 651 | 808 | 1550 | 973 | | | | | | | | | |
| 30 | 0 | 34 | 99 | 63 | 53 | 211 | 127 | 76 | 372 | 219 | 110 | 584 | 334 | 144 | 849 | 472 | 184 | 1168 | 647 | 229 | 1542 | 852 | 312 | 1971 | 1056 | 454 | 2996 | 1545 | | | | | | | | | |
| | 2 | 37 | 80 | 56 | 55 | 164 | 111 | 76 | 281 | 183 | 109 | 429 | 279 | 139 | 610 | 392 | 175 | 823 | 533 | 219 | 1069 | 698 | 296 | 1346 | 863 | 424 | 1999 | 1308 | | | | | | | | | |
| | 5 | 49 | 74 | 52 | 72 | 157 | 106 | 98 | 271 | 173 | 136 | 417 | 271 | 171 | 595 | 382 | 215 | 806 | 521 | 269 | 1049 | 684 | 366 | 1324 | 846 | 524 | 1971 | 1283 | | | | | | | | | |
| | 10 | NA | NA | NA | 91 | 144 | 98 | 122 | 255 | 168 | 171 | 397 | 257 | 213 | 570 | 367 | 265 | 777 | 501 | 327 | 1017 | 662 | 440 | 1287 | 821 | 620 | 1927 | 1243 | | | | | | | | | |
| | 15 | NA | NA | NA | 115 | 131 | NA | 151 | 239 | 157 | 208 | 377 | 242 | 255 | 547 | 349 | 312 | 750 | 481 | 379 | 985 | 638 | 507 | 1251 | 794 | 702 | 1884 | 1205 | | | | | | | | | |
| | 20 | NA | NA | NA | NA | NA | NA | 181 | 223 | NA | 246 | 357 | 228 | 298 | 524 | 333 | 360 | 723 | 461 | 433 | 955 | 615 | 570 | 1216 | 768 | 780 | 1841 | 1166 | | | | | | | | | |
| | 30 | NA | NA | NA | NA | NA | NA | NA | NA | NA | NA | NA | NA | 389 | 477 | 305 | 461 | 670 | 426 | 541 | 895 | 574 | 704 | 1147 | 720 | 937 | 1759 | 1101 | | | | | | | | | |
| 50 | 0 | 33 | 99 | 66 | 51 | 213 | 133 | 73 | 394 | 230 | 105 | 629 | 361 | 138 | 928 | 515 | 176 | 1292 | 704 | 220 | 1724 | 948 | 295 | 2223 | 1189 | 428 | 3432 | 1818 | | | | | | | | | |
| | 2 | 36 | 84 | 61 | 53 | 181 | 121 | 73 | 318 | 205 | 104 | 495 | 312 | 133 | 712 | 443 | 168 | 971 | 613 | 209 | 1273 | 811 | 280 | 1615 | 1007 | 401 | 2426 | 1509 | | | | | | | | | |
| | 5 | 48 | 80 | NA | 70 | 174 | 117 | 94 | 308 | 198 | 131 | 482 | 305 | 164 | 696 | 435 | 204 | 953 | 602 | 257 | 1252 | 795 | 347 | 1591 | 991 | 496 | 2396 | 1490 | | | | | | | | | |
| | 10 | NA | NA | NA | 89 | 160 | NA | 118 | 292 | 186 | 162 | 461 | 292 | 203 | 671 | 420 | 253 | 923 | 583 | 313 | 1217 | 765 | 418 | 1551 | 963 | 589 | 2347 | 1455 | | | | | | | | | |
| | 15 | NA | NA | NA | 112 | 148 | NA | 145 | 275 | 174 | 199 | 441 | 280 | 244 | 646 | 405 | 299 | 894 | 562 | 363 | 1183 | 736 | 481 | 1512 | 934 | 668 | 2299 | 1421 | | | | | | | | | |
| | 20 | NA | NA | NA | NA | NA | NA | 176 | 257 | NA | 236 | 420 | 267 | 285 | 622 | 389 | 345 | 866 | 543 | 415 | 1150 | 708 | 544 | 1473 | 906 | 741 | 2251 | 1387 | | | | | | | | | |
| | 30 | NA | NA | NA | NA | NA | NA | NA | NA | NA | 315 | 376 | NA | 373 | 573 | NA | 442 | 809 | 502 | 521 | 1086 | 649 | 674 | 1399 | 848 | 892 | 2159 | 1318 | | | | | | | | | |
| 100 | 0 | NA | NA | NA | 49 | 214 | NA | 69 | 403 | NA | 100 | 659 | 395 | 131 | 991 | 555 | 166 | 1404 | 765 | 207 | 1900 | 1033 | 273 | 2479 | 1300 | 395 | 3912 | 2042 | | | | | | | | | |
| | 2 | NA | NA | NA | 51 | 192 | NA | 70 | 351 | NA | 98 | 563 | 373 | 125 | 828 | 508 | 158 | 1152 | 698 | 196 | 1532 | 933 | 259 | 1970 | 1168 | 371 | 3021 | 1817 | | | | | | | | | |
| | 5 | NA | NA | NA | 67 | 186 | NA | 90 | 342 | NA | 125 | 551 | 366 | 156 | 813 | 501 | 194 | 1134 | 688 | 240 | 1511 | 921 | 322 | 1945 | 1153 | 460 | 2990 | 1796 | | | | | | | | | |
| | 10 | NA | NA | NA | 85 | 175 | NA | 113 | 324 | NA | 153 | 532 | 354 | 191 | 789 | 486 | 238 | 1104 | 672 | 293 | 1477 | 902 | 389 | 1905 | 1133 | 547 | 2938 | 1763 | | | | | | | | | |
| | 15 | NA | NA | NA | 132 | 162 | NA | 138 | 310 | NA | 188 | 511 | 343 | 230 | 764 | 473 | 281 | 1075 | 656 | 342 | 1443 | 884 | 447 | 1865 | 1110 | 618 | 2888 | 1730 | | | | | | | | | |
| | 20 | NA | NA | NA | NA | NA | NA | 168 | 295 | NA | 224 | 487 | NA | 270 | 739 | 458 | 325 | 1046 | 639 | 391 | 1410 | 864 | 507 | 1825 | 1087 | 690 | 2838 | 1696 | | | | | | | | | |
| | 30 | NA | NA | NA | NA | NA | NA | 231 | 264 | NA | 301 | 448 | NA | 355 | 685 | NA | 418 | 988 | NA | 491 | 1343 | 824 | 631 | 1747 | 1041 | 834 | 2739 | 1627 | | | | | | | | | |
| | 50 | NA | NA | NA | NA | NA | NA | NA | NA | NA | NA | NA | NA | 540 | 584 | NA | 617 | 866 | NA | 711 | 1205 | NA | 895 | 1591 | NA | 1138 | 2547 | 1489 | | | | | | | | | |

For SI units, 1 in. = 25.4 mm, 1 ft = 0.305 m, 1000 Btu/hr = 0.293 kW, 1 in.² = 645 mm².

NA: Not applicable.

Table 13.1(c) Masonry Chimney

| | | Number of Appliances: Single | | | | | | | | | | | | | | | | | | | | | | | | | | | |
|------------------------------------------------------|-----------------------------|--------------------------------------------------------------------------------------------------------------------------|-----|-----|-----|-----|-----|-----|-----|-----|-----|-----|-----|-----|-----|-----|-----|-----|-----|-----|------|-----|-----|------|-----|-----|------|------|--|
| | | Appliance Type: Category I | | | | | | | | | | | | | | | | | | | | | | | | | | | |
| | | Appliance Vent Connection: Type B Double-Wall Connector | | | | | | | | | | | | | | | | | | | | | | | | | | | |
| | | Type B Double-Wall Connector Diameter — <i>D</i> (in.) To be used with chimney areas within the size limits at bottom | | | | | | | | | | | | | | | | | | | | | | | | | | | |
| | | 3 | | 4 | | 5 | | 6 | | 7 | | 8 | | 9 | | 10 | | 12 | | | | | | | | | | | |
| Height <i>H</i> (ft) | Lateral <i>L</i> (ft) | Appliance Input Rating in Thousands of Btu per Hour | | | | | | | | | | | | | | | | | | | | | | | | | | | |
| | | FAN | | NAT | FAN | | NAT | FAN | | NAT | FAN | | NAT | FAN | | NAT | FAN | | NAT | FAN | | NAT | | | | | | | |
| | | Min | Max | Max | Min | Max | Max | Min | Max | Max | Min | Max | Max | Min | Max | Max | Min | Max | Max | Min | Max | Max | Min | Max | Max | | | | |
| 6 | 2 | NA | NA | 28 | NA | NA | 52 | NA | NA | 86 | NA | NA | 130 | NA | NA | 180 | NA | NA | 247 | NA | NA | 320 | NA | NA | 401 | NA | NA | 581 | |
| | 5 | NA | NA | 25 | NA | NA | 49 | NA | NA | 82 | NA | NA | 117 | NA | NA | 165 | NA | NA | 231 | NA | NA | 298 | NA | NA | 376 | NA | NA | 561 | |
| | 8 | NA | NA | 29 | NA | NA | 55 | NA | NA | 93 | NA | NA | 145 | NA | NA | 198 | NA | NA | 266 | 84 | 590 | 350 | 100 | 728 | 446 | 139 | 1024 | 651 | |
| 8 | 5 | NA | NA | 26 | NA | NA | 52 | NA | NA | 88 | NA | NA | 134 | NA | NA | 183 | NA | NA | 247 | NA | NA | 328 | 149 | 711 | 423 | 201 | 1007 | 640 | |
| | 8 | NA | NA | 24 | NA | NA | 48 | NA | NA | 83 | NA | NA | 127 | NA | NA | 175 | NA | NA | 239 | NA | NA | 318 | 173 | 695 | 410 | 231 | 990 | 623 | |
| | 10 | NA | NA | 31 | NA | NA | 61 | NA | NA | 103 | NA | NA | 162 | NA | NA | 221 | 68 | 519 | 298 | 82 | 655 | 388 | 98 | 810 | 491 | 136 | 1144 | 724 | |
| 10 | 5 | NA | NA | 28 | NA | NA | 57 | NA | NA | 96 | NA | NA | 148 | NA | NA | 204 | NA | NA | 277 | 124 | 638 | 365 | 146 | 791 | 466 | 196 | 1124 | 712 | |
| | 10 | NA | NA | 25 | NA | NA | 50 | NA | NA | 87 | NA | NA | 139 | NA | NA | 191 | NA | NA | 263 | 155 | 610 | 347 | 182 | 762 | 444 | 240 | 1093 | 668 | |
| | 15 | NA | NA | 35 | NA | NA | 67 | NA | NA | 114 | NA | NA | 179 | 53 | 475 | 250 | 64 | 613 | 336 | 77 | 779 | 441 | 92 | 968 | 562 | 127 | 1376 | 841 | |
| 15 | 5 | NA | NA | 35 | NA | NA | 62 | NA | NA | 107 | NA | NA | 164 | NA | NA | 231 | 99 | 594 | 313 | 118 | 759 | 416 | 139 | 946 | 533 | 186 | 1352 | 828 | |
| | 10 | NA | NA | 28 | NA | NA | 55 | NA | NA | 97 | NA | NA | 153 | NA | NA | 216 | 126 | 565 | 296 | 148 | 727 | 394 | 173 | 912 | 567 | 229 | 1315 | 777 | |
| | 15 | NA | NA | NA | NA | NA | 48 | NA | NA | 89 | NA | NA | 141 | NA | NA | 201 | NA | NA | 281 | 171 | 698 | 375 | 198 | 880 | 485 | 259 | 1280 | 742 | |
| 20 | 2 | NA | NA | 38 | NA | NA | 74 | NA | NA | 124 | NA | NA | 201 | 51 | 522 | 274 | 61 | 678 | 375 | 73 | 867 | 491 | 87 | 1083 | 627 | 121 | 1548 | 953 | |
| | 5 | NA | NA | 36 | NA | NA | 68 | NA | NA | 116 | NA | NA | 184 | 80 | 503 | 254 | 95 | 658 | 350 | 113 | 845 | 463 | 133 | 1059 | 597 | 179 | 1523 | 933 | |
| | 10 | NA | NA | NA | NA | NA | 60 | NA | NA | 107 | NA | NA | 172 | NA | NA | 237 | 122 | 627 | 332 | 143 | 811 | 440 | 167 | 1022 | 566 | 221 | 1482 | 879 | |
| | 15 | NA | NA | NA | NA | NA | NA | NA | NA | 97 | NA | NA | 159 | NA | NA | 220 | NA | NA | 314 | 165 | 780 | 418 | 191 | 987 | 541 | 251 | 1443 | 840 | |
| 20 | 20 | NA | NA | NA | NA | NA | NA | NA | NA | 83 | NA | NA | 148 | NA | NA | 206 | NA | NA | 296 | 186 | 750 | 397 | 214 | 955 | 513 | 277 | 1406 | 807 | |
| | 30 | NA | NA | 41 | NA | NA | 82 | NA | NA | 137 | NA | NA | 216 | 47 | 581 | 303 | 57 | 762 | 421 | 68 | 985 | 558 | 81 | 1240 | 717 | 111 | 1793 | 1112 | |
| | 5 | NA | NA | NA | NA | NA | 76 | NA | NA | 128 | NA | NA | 198 | 75 | 561 | 281 | 90 | 741 | 393 | 106 | 962 | 526 | 125 | 1216 | 683 | 169 | 1766 | 1094 | |
| | 10 | NA | NA | NA | NA | NA | 67 | NA | NA | 115 | NA | NA | 184 | NA | NA | 263 | 115 | 709 | 373 | 135 | 927 | 500 | 158 | 1176 | 648 | 210 | 1721 | 1025 | |
| 30 | 15 | NA | NA | NA | NA | NA | NA | NA | NA | 107 | NA | NA | 171 | NA | NA | 243 | NA | NA | 353 | 156 | 893 | 476 | 181 | 1139 | 621 | 239 | 1679 | 981 | |
| | 20 | NA | NA | NA | NA | NA | NA | NA | NA | 91 | NA | NA | 159 | NA | NA | 227 | NA | NA | 332 | 176 | 860 | 450 | 203 | 1103 | 592 | 264 | 1638 | 940 | |
| | 30 | NA | NA | NA | NA | NA | NA | NA | NA | NA | NA | NA | NA | NA | NA | 188 | NA | NA | 288 | NA | NA | 416 | 249 | 1035 | 555 | 318 | 1560 | 877 | |
| | 50 | NA | NA | NA | NA | NA | 92 | NA | NA | 161 | NA | NA | 251 | NA | NA | 351 | 51 | 840 | 477 | 61 | 1106 | 633 | 72 | 1413 | 812 | 99 | 2080 | 1243 | |
| 50 | 2 | NA | NA | NA | NA | NA | NA | NA | NA | 151 | NA | NA | 230 | NA | NA | 323 | 83 | 819 | 445 | 98 | 1083 | 596 | 116 | 1387 | 774 | 155 | 2052 | 1225 | |
| | 5 | NA | NA | NA | NA | NA | NA | NA | NA | 138 | NA | NA | 215 | NA | NA | 304 | NA | NA | 424 | 126 | 1047 | 567 | 147 | 1347 | 733 | 195 | 2006 | 1147 | |
| | 10 | NA | NA | NA | NA | NA | NA | NA | NA | 127 | NA | NA | 199 | NA | NA | 282 | NA | NA | 400 | 146 | 1010 | 539 | 170 | 1307 | 702 | 222 | 1961 | 1099 | |
| | 15 | NA | NA | NA | NA | NA | NA | NA | NA | NA | NA | NA | 185 | NA | NA | 264 | NA | NA | 376 | 165 | 977 | 511 | 190 | 1269 | 669 | 246 | 1916 | 1050 | |
| 50 | 20 | NA | NA | NA | NA | NA | NA | NA | NA | NA | NA | NA | NA | NA | NA | NA | NA | NA | 327 | NA | NA | 468 | 233 | 1196 | 623 | 295 | 1832 | 984 | |
| | 30 | NA | NA | NA | NA | NA | NA | NA | NA | NA | NA | NA | NA | NA | NA | NA | NA | NA | NA | NA | NA | NA | NA | NA | NA | NA | NA | NA | |
| | 50 | NA | NA | NA | NA | NA | NA | NA | NA | NA | NA | NA | NA | NA | NA | NA | NA | NA | NA | NA | NA | NA | NA | NA | NA | NA | NA | NA | |
| | 50 | NA | NA | NA | NA | NA | NA | NA | NA | NA | NA | NA | NA | NA | NA | NA | NA | NA | NA | NA | NA | NA | NA | NA | NA | NA | NA | NA | |
| Minimum internal area of chimney (in. ²) | | 12 | | 19 | | 28 | | 38 | | 50 | | 63 | | 78 | | 95 | | 132 | | | | | | | | | | | |
| Maximum internal area of chimney (in. ²) | | Seven times the listed appliance categorized vent area, flue collar area, or draft hood outlet areas. | | | | | | | | | | | | | | | | | | | | | | | | | | | |

For SI units, 1 in. = 25.4 mm, 1 ft = 0.305 m, 1000 Btu/hr = 0.293 kW, 1 in.² = 645 mm².

NA: Not applicable.

Table 13.1(d) Masonry Chimney

| | | Number of Appliances: Single | | | | | | | | | | | | | | | | | | | | | | | | | | | | | | | | | | | |
|------------------------------------------------------|-----------------------------|-------------------------------------------------------------------------------------------------------------------------|-----|-----|-----|-----|-----|-----|-----|-----|-----|-----|-----|-----|-----|-----|-----|-----|-----|-----|------|-----|-----|------|------|------|------|------|--|--|--|--|--|--|--|--|--|
| | | Appliance Type: Category I | | | | | | | | | | | | | | | | | | | | | | | | | | | | | | | | | | | |
| | | Appliance Vent Connection: Single-Wall Metal Connector | | | | | | | | | | | | | | | | | | | | | | | | | | | | | | | | | | | |
| | | Single-Wall Metal Connector Diameter — <i>D</i> (in.) To be used with chimney areas within the size limits at bottom | | | | | | | | | | | | | | | | | | | | | | | | | | | | | | | | | | | |
| | | 3 | | | 4 | | | 5 | | | 6 | | | 7 | | | 8 | | | 9 | | | 10 | | | 12 | | | | | | | | | | | |
| Height <i>H</i> (ft) | Lateral <i>L</i> (ft) | Appliance Input Rating in Thousands of Btu per Hour | | | | | | | | | | | | | | | | | | | | | | | | | | | | | | | | | | | |
| | | FAN | | NAT | FAN | | NAT | FAN | | NAT | FAN | | NAT | FAN | | NAT | FAN | | NAT | FAN | | NAT | FAN | | NAT | FAN | | NAT | | | | | | | | | |
| | | Min | Max | Max | Min | Max | Max | Min | Max | Max | Min | Max | Max | Min | Max | Max | Min | Max | Max | Min | Max | Max | Min | Max | Max | Min | Max | Max | | | | | | | | | |
| 6 | 2 | NA | NA | 28 | NA | NA | 52 | NA | NA | 86 | NA | NA | 130 | NA | NA | 180 | NA | NA | 247 | NA | NA | 319 | NA | NA | 400 | NA | NA | 580 | | | | | | | | | |
| | 5 | NA | NA | 25 | NA | NA | 48 | NA | NA | 81 | NA | NA | 116 | NA | NA | 164 | NA | NA | 230 | NA | NA | 297 | NA | NA | 375 | NA | NA | 560 | | | | | | | | | |
| | 8 | NA | NA | 29 | NA | NA | 55 | NA | NA | 93 | NA | NA | 145 | NA | NA | 197 | NA | NA | 265 | NA | NA | 349 | 382 | 725 | 445 | 549 | 1021 | 650 | | | | | | | | | |
| 8 | 5 | NA | NA | 26 | NA | NA | 51 | NA | NA | 87 | NA | NA | 133 | NA | NA | 182 | NA | NA | 246 | NA | NA | 327 | NA | NA | 422 | 673 | 1003 | 638 | | | | | | | | | |
| | 8 | NA | NA | 23 | NA | NA | 47 | NA | NA | 82 | NA | NA | 126 | NA | NA | 174 | NA | NA | 237 | NA | NA | 317 | NA | NA | 408 | 747 | 985 | 621 | | | | | | | | | |
| | 10 | NA | NA | 31 | NA | NA | 61 | NA | NA | 102 | NA | NA | 161 | NA | NA | 220 | 216 | 518 | 297 | 271 | 654 | 387 | 373 | 808 | 490 | 536 | 1142 | 722 | | | | | | | | | |
| 10 | 5 | NA | NA | 28 | NA | NA | 56 | NA | NA | 95 | NA | NA | 147 | NA | NA | 203 | NA | NA | 276 | 334 | 635 | 364 | 459 | 789 | 465 | 657 | 1121 | 710 | | | | | | | | | |
| | 10 | NA | NA | 24 | NA | NA | 49 | NA | NA | 86 | NA | NA | 137 | NA | NA | 189 | NA | NA | 261 | NA | NA | 345 | 547 | 758 | 441 | 771 | 1088 | 665 | | | | | | | | | |
| | 15 | NA | NA | 35 | NA | NA | 67 | NA | NA | 113 | NA | NA | 178 | 166 | 473 | 249 | 211 | 611 | 335 | 264 | 776 | 440 | 362 | 965 | 560 | 520 | 1373 | 840 | | | | | | | | | |
| 15 | 5 | NA | NA | 32 | NA | NA | 61 | NA | NA | 106 | NA | NA | 163 | NA | NA | 230 | 261 | 591 | 312 | 325 | 755 | 414 | 444 | 942 | 531 | 637 | 1348 | 825 | | | | | | | | | |
| | 10 | NA | NA | 27 | NA | NA | 54 | NA | NA | 96 | NA | NA | 151 | NA | NA | 214 | NA | NA | 294 | 392 | 722 | 392 | 531 | 907 | 504 | 749 | 1309 | 774 | | | | | | | | | |
| | 15 | NA | NA | NA | NA | NA | 46 | NA | NA | 87 | NA | NA | 138 | NA | NA | 198 | NA | NA | 278 | 452 | 692 | 372 | 606 | 873 | 481 | 841 | 1272 | 738 | | | | | | | | | |
| 20 | 2 | NA | NA | 38 | NA | NA | 73 | NA | NA | 123 | NA | NA | 200 | 163 | 520 | 273 | 206 | 675 | 374 | 258 | 864 | 490 | 252 | 1079 | 625 | 508 | 1544 | 950 | | | | | | | | | |
| | 5 | NA | NA | 35 | NA | NA | 67 | NA | NA | 115 | NA | NA | 183 | NA | NA | 252 | 255 | 655 | 348 | 317 | 842 | 461 | 433 | 1055 | 594 | 623 | 1518 | 930 | | | | | | | | | |
| | 10 | NA | NA | NA | NA | NA | 59 | NA | NA | 105 | NA | NA | 170 | NA | NA | 235 | 312 | 622 | 330 | 382 | 806 | 437 | 517 | 1016 | 562 | 733 | 1475 | 875 | | | | | | | | | |
| | 15 | NA | NA | NA | NA | NA | NA | NA | NA | 95 | NA | NA | 156 | NA | NA | 217 | NA | NA | 311 | 442 | 773 | 414 | 591 | 979 | 539 | 823 | 1434 | 835 | | | | | | | | | |
| 20 | 20 | NA | NA | NA | NA | NA | NA | NA | NA | 80 | NA | NA | 144 | NA | NA | 202 | NA | NA | 292 | NA | NA | 392 | 663 | 944 | 510 | 911 | 1394 | 800 | | | | | | | | | |
| | 30 | NA | NA | 41 | NA | NA | 81 | NA | NA | 136 | NA | NA | 215 | 158 | 578 | 302 | 200 | 759 | 420 | 249 | 982 | 556 | 340 | 1237 | 715 | 489 | 1789 | 1110 | | | | | | | | | |
| | 5 | NA | NA | NA | NA | NA | 75 | NA | NA | 127 | NA | NA | 196 | NA | NA | 279 | 245 | 737 | 391 | 306 | 958 | 524 | 417 | 1210 | 680 | 600 | 1760 | 1090 | | | | | | | | | |
| | 10 | NA | NA | NA | NA | NA | 66 | NA | NA | 113 | NA | NA | 182 | NA | NA | 260 | 300 | 703 | 370 | 370 | 920 | 496 | 500 | 1168 | 644 | 708 | 1713 | 1020 | | | | | | | | | |
| 30 | 15 | NA | NA | NA | NA | NA | NA | NA | NA | 105 | NA | NA | 168 | NA | NA | 240 | NA | NA | 349 | 428 | 884 | 471 | 572 | 1128 | 615 | 798 | 1668 | 975 | | | | | | | | | |
| | 20 | NA | NA | NA | NA | NA | NA | NA | NA | 88 | NA | NA | 155 | NA | NA | 223 | NA | NA | 327 | NA | NA | 445 | 643 | 1089 | 585 | 883 | 1624 | 932 | | | | | | | | | |
| | 30 | NA | NA | NA | NA | NA | NA | NA | NA | NA | NA | NA | NA | NA | NA | 182 | NA | NA | 281 | NA | NA | 408 | NA | NA | 544 | 1055 | 1539 | 865 | | | | | | | | | |
| 50 | 2 | NA | NA | NA | NA | NA | 91 | NA | NA | 160 | NA | NA | 250 | NA | NA | 350 | 191 | 837 | 475 | 238 | 1103 | 631 | 323 | 1408 | 810 | 463 | 2076 | 1240 | | | | | | | | | |
| | 5 | NA | NA | NA | NA | NA | NA | NA | NA | 149 | NA | NA | 228 | NA | NA | 321 | NA | NA | 442 | 293 | 1078 | 593 | 398 | 1381 | 770 | 571 | 2044 | 1220 | | | | | | | | | |
| | 10 | NA | NA | NA | NA | NA | NA | NA | NA | 136 | NA | NA | 212 | NA | NA | 301 | NA | NA | 420 | 355 | 1038 | 562 | 447 | 1337 | 728 | 674 | 1994 | 1140 | | | | | | | | | |
| | 15 | NA | NA | NA | NA | NA | NA | NA | NA | 124 | NA | NA | 195 | NA | NA | 278 | NA | NA | 395 | NA | NA | 533 | 546 | 1294 | 695 | 761 | 1945 | 1090 | | | | | | | | | |
| | 20 | NA | NA | NA | NA | NA | NA | NA | NA | NA | NA | NA | 180 | NA | NA | 258 | NA | NA | 370 | NA | NA | 504 | 616 | 1251 | 660 | 844 | 1898 | 1040 | | | | | | | | | |
| 30 | NA | NA | NA | NA | NA | NA | NA | NA | NA | NA | NA | NA | NA | NA | NA | NA | NA | 318 | NA | NA | 458 | NA | NA | 610 | 1009 | 1805 | 970 | | | | | | | | | | |
| Minimum internal area of chimney (in. ²) | | 12 | | 19 | | 28 | | 38 | | 50 | | 63 | | 78 | | 95 | | 132 | | | | | | | | | | | | | | | | | | | |
| Maximum internal area of chimney (in. ²) | | Seven times the listed appliance categorized vent area, flue collar area, or draft hood outlet areas. | | | | | | | | | | | | | | | | | | | | | | | | | | | | | | | | | | | |

For SI units, 1 in. = 25.4 mm, 1 ft = 0.305 m, 1000 Btu/hr = 0.293 kW, 1 in.² = 645 mm².

NA: Not applicable.

Table 13.1(e) Single-Wall Metal Pipe or Type B Asbestos Cement Vent

| | | Number of Appliances: Single | | | | | | | |
|----------------------------|-----------------------------|----------------------------------------------------------------------|-----|-----|-----|-----|-----|-----|------|
| | | Appliance Type: Draft Hood-Equipped | | | | | | | |
| | | Appliance Vent Connection: Connected Directly to Pipe or Vent | | | | | | | |
| Height <i>H</i> (ft) | Lateral <i>L</i> (ft) | Diameter — <i>D</i> (in.) | | | | | | | |
| | | To be used with chimney areas within the size limits at bottom | | | | | | | |
| | | 3 | 4 | 5 | 6 | 7 | 8 | 10 | 12 |
| | | Appliance Input Rating in Thousands of Btu per Hour | | | | | | | |
| | | Maximum Appliance Input Rating in Thousands of Btu per Hour | | | | | | | |
| 6 | 0 | 39 | 70 | 116 | 170 | 232 | 312 | 500 | 750 |
| | 2 | 31 | 55 | 94 | 141 | 194 | 260 | 415 | 620 |
| | 5 | 28 | 51 | 88 | 128 | 177 | 242 | 390 | 600 |
| 8 | 0 | 42 | 76 | 126 | 185 | 252 | 340 | 542 | 815 |
| | 2 | 32 | 61 | 102 | 154 | 210 | 284 | 451 | 680 |
| | 5 | 29 | 56 | 95 | 141 | 194 | 264 | 430 | 648 |
| | 10 | 24 | 49 | 86 | 131 | 180 | 250 | 406 | 625 |
| 10 | 0 | 45 | 84 | 138 | 202 | 279 | 372 | 606 | 912 |
| | 2 | 35 | 67 | 111 | 168 | 233 | 311 | 505 | 760 |
| | 5 | 32 | 61 | 104 | 153 | 215 | 289 | 480 | 724 |
| | 10 | 27 | 54 | 94 | 143 | 200 | 274 | 455 | 700 |
| | 15 | NA | 46 | 84 | 130 | 186 | 258 | 432 | 666 |
| 15 | 0 | 49 | 91 | 151 | 223 | 312 | 420 | 684 | 1040 |
| | 2 | 39 | 72 | 122 | 186 | 260 | 350 | 570 | 865 |
| | 5 | 35 | 67 | 110 | 170 | 240 | 325 | 540 | 825 |
| | 10 | 30 | 58 | 103 | 158 | 223 | 308 | 514 | 795 |
| | 15 | NA | 50 | 93 | 144 | 207 | 291 | 488 | 760 |
| | 20 | NA | NA | 82 | 132 | 195 | 273 | 466 | 726 |
| 20 | 0 | 53 | 101 | 163 | 252 | 342 | 470 | 770 | 1190 |
| | 2 | 42 | 80 | 136 | 210 | 286 | 392 | 641 | 990 |
| | 5 | 38 | 74 | 123 | 192 | 264 | 364 | 610 | 945 |
| | 10 | 32 | 65 | 115 | 178 | 246 | 345 | 571 | 910 |
| | 15 | NA | 55 | 104 | 163 | 228 | 326 | 550 | 870 |
| | 20 | NA | NA | 91 | 149 | 214 | 306 | 525 | 832 |
| 30 | 0 | 56 | 108 | 183 | 276 | 384 | 529 | 878 | 1370 |
| | 2 | 44 | 84 | 148 | 230 | 320 | 441 | 730 | 1140 |
| | 5 | NA | 78 | 137 | 210 | 296 | 410 | 694 | 1080 |
| | 10 | NA | 68 | 125 | 196 | 274 | 388 | 656 | 1050 |
| | 15 | NA | NA | 113 | 177 | 258 | 366 | 625 | 1000 |
| | 20 | NA | NA | 99 | 163 | 240 | 344 | 596 | 960 |
| | 30 | NA | NA | NA | NA | 192 | 295 | 540 | 890 |
| 50 | 0 | NA | 120 | 210 | 310 | 443 | 590 | 980 | 1550 |
| | 2 | NA | 95 | 171 | 260 | 370 | 492 | 820 | 1290 |
| | 5 | NA | NA | 159 | 234 | 342 | 474 | 780 | 1230 |
| | 10 | NA | NA | 146 | 221 | 318 | 456 | 730 | 1190 |
| | 15 | NA | NA | NA | 200 | 292 | 407 | 705 | 1130 |
| | 20 | NA | NA | NA | 185 | 276 | 384 | 670 | 1080 |
| | 30 | NA | NA | NA | NA | 222 | 330 | 605 | 1010 |

For SI units, 1 in. = 25.4 mm, 1 ft = 0.305 m, 1000 Btu/hr = 0.293 kW, 1 in.² = 645 mm².

NA: Not applicable.

Table 13.1(f) Exterior Masonry Chimney

| | | Number of Appliances: | | Single | | | | | |
|----------------------------------------------------------------------------------------------------|----------------------------------------------|----------------------------|-----|------------------------------|-----|-----|-----|------|------|
| | | Appliance Type: | | NAT | | | | | |
| | | Appliance Vent Connection: | | Type B Double-Wall Connector | | | | | |
| Minimum Allowable Input Rating of Space-Heating Appliance in Thousands of Btu per Hour | | | | | | | | | |
| Vent Height <i>H</i> (ft) | Internal Area of Chimney (in. ²) | | | | | | | | |
| | 12 | 19 | 28 | 38 | 50 | 63 | 78 | 113 | |
| Local 99% winter design temperature: 37°F or greater | | | | | | | | | |
| 6 | 0 | 0 | 0 | 0 | 0 | 0 | 0 | 0 | 0 |
| 8 | 0 | 0 | 0 | 0 | 0 | 0 | 0 | 0 | 0 |
| 10 | 0 | 0 | 0 | 0 | 0 | 0 | 0 | 0 | 0 |
| 15 | NA | 0 | 0 | 0 | 0 | 0 | 0 | 0 | 0 |
| 20 | NA | NA | 123 | 190 | 249 | 184 | 0 | 0 | 0 |
| 30 | NA | NA | NA | NA | NA | 393 | 334 | 0 | 0 |
| 50 | NA | NA | NA | NA | NA | NA | NA | 579 | 579 |
| Local 99% winter design temperature: 27°F to 36°F | | | | | | | | | |
| 6 | 0 | 0 | 68 | 116 | 156 | 180 | 212 | 266 | 266 |
| 8 | 0 | 0 | 82 | 127 | 167 | 187 | 214 | 263 | 263 |
| 10 | 0 | 51 | 97 | 141 | 183 | 201 | 225 | 265 | 265 |
| 15 | NA | NA | NA | NA | 233 | 253 | 274 | 305 | 305 |
| 20 | NA | NA | NA | NA | NA | 307 | 330 | 362 | 362 |
| 30 | NA | NA | NA | NA | NA | 419 | 445 | 485 | 485 |
| 50 | NA | NA | NA | NA | NA | NA | NA | 763 | 763 |
| Local 99% winter design temperature: 17°F to 26°F | | | | | | | | | |
| 6 | NA | NA | NA | NA | NA | 215 | 259 | 349 | 349 |
| 8 | NA | NA | NA | NA | 197 | 226 | 264 | 352 | 352 |
| 10 | NA | NA | NA | NA | 214 | 245 | 278 | 358 | 358 |
| 15 | NA | NA | NA | NA | NA | 296 | 331 | 398 | 398 |
| 20 | NA | NA | NA | NA | NA | 352 | 387 | 457 | 457 |
| 30 | NA | NA | NA | NA | NA | NA | 507 | 581 | 581 |
| 50 | NA | NA | NA | NA | NA | NA | NA | NA | NA |
| Local 99% winter design temperature: 5°F to 16°F | | | | | | | | | |
| 6 | NA | NA | NA | NA | NA | NA | NA | 416 | 416 |
| 8 | NA | NA | NA | NA | NA | NA | 312 | 423 | 423 |
| 10 | NA | NA | NA | NA | NA | 289 | 331 | 430 | 430 |
| 15 | NA | NA | NA | NA | NA | NA | 393 | 485 | 485 |
| 20 | NA | NA | NA | NA | NA | NA | 450 | 547 | 547 |
| 30 | NA | NA | NA | NA | NA | NA | NA | 682 | 682 |
| 50 | NA | NA | NA | NA | NA | NA | NA | 972 | 972 |
| Local 99% winter design temperature: -10°F to 4°F | | | | | | | | | |
| 6 | NA | NA | NA | NA | NA | NA | NA | 484 | 484 |
| 8 | NA | NA | NA | NA | NA | NA | NA | 494 | 494 |
| 10 | NA | NA | NA | NA | NA | NA | NA | 513 | 513 |
| 15 | NA | NA | NA | NA | NA | NA | NA | 586 | 586 |
| 20 | NA | NA | NA | NA | NA | NA | NA | 650 | 650 |
| 30 | NA | NA | NA | NA | NA | NA | NA | 805 | 805 |
| 50 | NA | NA | NA | NA | NA | NA | NA | 1003 | 1003 |
| Local 99% winter design temperature: -11°F or lower Not recommended for any vent configurations | | | | | | | | | |

For SI units, 1 in. = 25.4 mm, 1 in.² = 645 mm², 1 ft = 0.305 m, 1000 Btu/hr = 0.293 kW, °C = (°F - 32)/1.8.

Note: See Figure F.2.4 for a map showing local 99 percent winter design temperatures in the United States.

NA: Not applicable.

13.1.11 Chimneys and Vent Locations. Table 13.1(a) through Table 13.1(e) shall be used only for chimneys and vents not exposed to the outdoors below the roof line. A Type B vent or listed chimney lining system passing through an unused masonry chimney flue shall not be considered to be exposed to the outdoors. Where vents extend outdoors above the roof more than 5 ft (1.5 m) higher than required by Table 12.7.3, and where vents terminate in accordance with 12.7.3(1)(b), the outdoor portion of the vent shall be enclosed as required by this paragraph for vents not considered to be exposed to the outdoors, or such venting system shall be engineered. A Type B vent passing through an unventilated enclosure or chase insulated to a value of not less than R8 shall not be considered to be exposed to the outdoors. Table 13.1(c) in combination with Table 13.1(f) shall be used for clay tile-lined exterior masonry chimneys, provided all of the following requirements are met:

- (1) The vent connector is Type B double wall.
- (2) The vent connector length is limited to 18 in./in. (18 mm/mm) of vent connector diameter.
- (3) The appliance is draft hood equipped.
- (4) The input rating is less than the maximum capacity given in Table 13.1(c).
- (5) For a water heater, the outdoor design temperature shall not be less than 5°F (−15°C).
- (6) For a space-heating appliance, the input rating is greater than the minimum capacity given by Table 13.1(f).

13.1.12 Corrugated Vent Connector Size. Corrugated vent connectors shall not be smaller than the listed appliance categorized vent diameter, flue collar diameter, or draft hood outlet diameter.

13.1.13 Upsizing. Vent connectors shall not be upsized more than two sizes greater than the listed appliance categorized vent diameter, flue collar diameter, or draft hood outlet diameter.

13.1.14 Multiple Vertical Vent Sizes. In a single run of vent or vent connector, more than one diameter and type shall be permitted to be used, provided that all the sizes and types are permitted by the tables.

13.1.15 Interpolation. Interpolation shall be permitted in calculating capacities for vent dimensions that fall between table entries.

13.1.16 Extrapolation. Extrapolation beyond the table entries shall not be permitted.

13.1.17 Sizing Vents Not Covered by Tables. For vent heights lower than 6 ft (1.8 m) and higher than shown in the Chapter 13 tables, engineering methods shall be used to calculate vent capacities.

Δ 13.1.18 Height Entries. Where the actual height of a vent falls between entries in the height column of the applicable table in Table 13.1(a) through Table 13.1(f) either of the following shall be used:

- (1) Interpolation
- (2) The lower appliance input rating shown in the table entries for FAN **Max** and NAT **Max** column values; and the higher appliance input rating for the FAN **Min** column values

Δ 13.2 Additional Requirements to Multiple-Appliance Vent. This section shall apply where Table 13.2(a) through Table 13.2(i) are used to size multiple appliance venting systems.

Subsections 13.2.1 through 13.2.30 apply to Table 13.2(a) through Table 13.2(i).

13.2.1 Obstructions and Vent Dampers. Venting Table 13.2(a) through Table 13.2(i) shall not be used where obstructions are installed in the venting system. The installation of vents serving listed appliances with vent dampers shall be in accordance with the appliance manufacturer's instructions, or in accordance with the following:

- (1) The maximum capacity of the vent connector shall be determined using the NAT **Max** column.
- (2) The maximum capacity of the vertical vent or chimney shall be determined using the FAN+NAT column when the second appliance is a fan-assisted appliance, or the NAT+NAT column when the second appliance is equipped with a draft hood.
- (3) The minimum capacity shall be determined as if the appliance were a fan-assisted appliance, as follows:
 - (a) The minimum capacity of the vent connector shall be determined using the FAN **Min** column.
 - (b) The FAN+FAN column shall be used when the second appliance is a fan-assisted appliance, and the FAN+NAT column shall be used when the second appliance is equipped with a draft hood, to determine whether the vertical vent or chimney configuration is not permitted (NA). Where the vent configuration is NA, the vent configuration shall not be permitted and an alternative venting configuration shall be utilized.

13.2.2 Vent Connector Maximum Length. The maximum vent connector horizontal length shall be 18 in./in. (18 mm/mm) of connector diameter as shown in Table 13.2.2, or as permitted by 13.2.3.

Table 13.2.2 Vent Connector Maximum Length

| Connector Diameter (in.) | Maximum Connector Horizontal Length (ft) |
|--------------------------|------------------------------------------|
| 3 | 4½ |
| 4 | 6 |
| 5 | 7½ |
| 6 | 9 |
| 7 | 10½ |
| 8 | 12 |
| 9 | 13½ |
| 10 | 15 |
| 12 | 18 |
| 14 | 21 |
| 16 | 24 |
| 18 | 27 |
| 20 | 30 |
| 22 | 33 |
| 24 | 36 |

For SI units, 1 in. = 25.4 mm, 1 ft = 0.305 m.

Table 13.2(a) Type B Double-Wall Vent

| | | Number of Appliances: Two or More | | | | | | | | | | | | | | | | | | | | | | | |
|-------------------------|-----------------------|------------------------------------------------------------|-----|-----|-----|-----|-----|-----|-----|-----|-----|-----|-----|-----|-----|-----|-----|-----|-----|-----|------|-----|-----|------|-----|
| | | Appliance Type: Category I | | | | | | | | | | | | | | | | | | | | | | | |
| | | Appliance Vent Connection: Type B Double-Wall Connector | | | | | | | | | | | | | | | | | | | | | | | |
| Vent Connector Capacity | | Type B Double-Wall Vent and Connector Diameter — D (in.) | | | | | | | | | | | | | | | | | | | | | | | |
| | | 3 | | | 4 | | | 5 | | | 6 | | | 7 | | | 8 | | | 9 | | | 10 | | |
| | | Appliance Input Rating Limits in Thousands of Btu per Hour | | | | | | | | | | | | | | | | | | | | | | | |
| Vent Height H (ft) | Connector Rise R (ft) | FAN | | NAT | FAN | | NAT | FAN | | NAT | FAN | | NAT | FAN | | NAT | FAN | | NAT | FAN | | NAT | FAN | | NAT |
| | | Min | Max | Max | Min | Max | Max | Min | Max | Max | Min | Max | Max | Min | Max | Max | Min | Max | Max | Min | Max | Max | Min | Max | Max |
| 6 | 1 | 22 | 37 | 26 | 35 | 66 | 46 | 46 | 106 | 72 | 58 | 164 | 104 | 77 | 225 | 142 | 92 | 296 | 185 | 109 | 376 | 237 | 128 | 466 | 289 |
| | 2 | 23 | 41 | 31 | 37 | 75 | 55 | 48 | 121 | 86 | 60 | 183 | 124 | 79 | 253 | 168 | 95 | 333 | 220 | 112 | 424 | 282 | 131 | 526 | 345 |
| | 3 | 24 | 44 | 35 | 38 | 81 | 62 | 49 | 132 | 96 | 62 | 199 | 139 | 82 | 275 | 189 | 97 | 363 | 248 | 114 | 463 | 317 | 134 | 575 | 386 |
| 8 | 1 | 22 | 40 | 27 | 35 | 72 | 48 | 49 | 114 | 76 | 64 | 176 | 109 | 84 | 243 | 148 | 100 | 320 | 194 | 118 | 408 | 248 | 138 | 507 | 303 |
| | 2 | 23 | 44 | 32 | 36 | 80 | 57 | 51 | 128 | 90 | 66 | 195 | 129 | 86 | 269 | 175 | 103 | 356 | 230 | 121 | 454 | 294 | 141 | 564 | 358 |
| | 3 | 24 | 47 | 36 | 37 | 87 | 64 | 53 | 139 | 101 | 67 | 210 | 145 | 88 | 290 | 198 | 105 | 384 | 258 | 123 | 492 | 330 | 143 | 612 | 402 |
| 10 | 1 | 22 | 43 | 28 | 34 | 78 | 50 | 49 | 123 | 78 | 65 | 189 | 113 | 89 | 257 | 154 | 106 | 341 | 200 | 125 | 436 | 257 | 146 | 542 | 314 |
| | 2 | 23 | 47 | 33 | 36 | 86 | 59 | 51 | 136 | 93 | 67 | 206 | 134 | 91 | 282 | 182 | 109 | 374 | 238 | 128 | 479 | 305 | 149 | 596 | 372 |
| | 3 | 24 | 50 | 37 | 37 | 92 | 67 | 52 | 146 | 104 | 69 | 220 | 150 | 94 | 303 | 205 | 111 | 402 | 268 | 131 | 515 | 342 | 152 | 642 | 417 |
| 15 | 1 | 21 | 50 | 30 | 33 | 89 | 53 | 47 | 142 | 83 | 64 | 220 | 120 | 88 | 298 | 163 | 110 | 389 | 214 | 134 | 493 | 273 | 162 | 609 | 333 |
| | 2 | 22 | 53 | 35 | 35 | 96 | 63 | 49 | 153 | 99 | 66 | 235 | 142 | 91 | 320 | 193 | 112 | 419 | 253 | 137 | 532 | 323 | 165 | 658 | 394 |
| | 3 | 24 | 55 | 40 | 36 | 102 | 71 | 51 | 163 | 111 | 68 | 248 | 160 | 93 | 339 | 218 | 115 | 445 | 286 | 140 | 565 | 365 | 167 | 700 | 444 |
| 20 | 1 | 21 | 54 | 31 | 33 | 99 | 56 | 46 | 157 | 87 | 62 | 246 | 125 | 86 | 334 | 171 | 107 | 436 | 224 | 131 | 552 | 285 | 158 | 681 | 347 |
| | 2 | 22 | 57 | 37 | 34 | 105 | 66 | 48 | 167 | 104 | 64 | 259 | 149 | 89 | 354 | 202 | 110 | 463 | 265 | 134 | 587 | 339 | 161 | 725 | 414 |
| | 3 | 23 | 60 | 42 | 35 | 110 | 74 | 50 | 176 | 116 | 66 | 271 | 168 | 91 | 371 | 228 | 113 | 486 | 300 | 137 | 618 | 383 | 164 | 764 | 466 |
| 30 | 1 | 20 | 62 | 33 | 31 | 113 | 59 | 45 | 181 | 93 | 60 | 288 | 134 | 83 | 391 | 182 | 103 | 512 | 238 | 125 | 649 | 305 | 151 | 802 | 372 |
| | 2 | 21 | 64 | 39 | 33 | 118 | 70 | 47 | 190 | 110 | 62 | 299 | 158 | 85 | 408 | 215 | 105 | 535 | 282 | 129 | 679 | 360 | 155 | 840 | 439 |
| | 3 | 22 | 66 | 44 | 34 | 123 | 79 | 48 | 198 | 124 | 64 | 309 | 178 | 88 | 423 | 242 | 108 | 555 | 317 | 132 | 706 | 405 | 158 | 874 | 494 |
| 50 | 1 | 19 | 71 | 36 | 30 | 133 | 64 | 43 | 216 | 101 | 57 | 349 | 145 | 78 | 477 | 197 | 97 | 627 | 257 | 120 | 797 | 330 | 144 | 984 | 403 |
| | 2 | 21 | 73 | 43 | 32 | 137 | 76 | 45 | 223 | 119 | 59 | 358 | 172 | 81 | 490 | 234 | 100 | 645 | 306 | 123 | 820 | 392 | 148 | 1014 | 478 |
| | 3 | 22 | 75 | 48 | 33 | 141 | 86 | 46 | 229 | 134 | 61 | 366 | 194 | 83 | 502 | 263 | 103 | 661 | 343 | 126 | 842 | 441 | 151 | 1043 | 538 |
| 100 | 1 | 18 | 82 | 37 | 28 | 158 | 66 | 40 | 262 | 104 | 53 | 442 | 150 | 73 | 611 | 204 | 91 | 810 | 266 | 112 | 1038 | 341 | 135 | 1285 | 417 |
| | 2 | 19 | 83 | 44 | 30 | 161 | 79 | 42 | 267 | 123 | 55 | 447 | 178 | 75 | 619 | 242 | 94 | 822 | 316 | 115 | 1054 | 405 | 139 | 1306 | 494 |
| | 3 | 20 | 84 | 50 | 31 | 163 | 89 | 44 | 272 | 138 | 57 | 452 | 200 | 78 | 627 | 272 | 97 | 834 | 355 | 118 | 1069 | 455 | 142 | 1327 | 555 |

Common Vent Capacity

| | | Type B Double-Wall Common Vent Diameter — D (in.) | | | | | | | | | | | | | | | | | | | | |
|--------------------|--|--------------------------------------------------------------|----------|----------|----------|----------|----------|----------|----------|----------|----------|----------|----------|----------|----------|----------|----------|----------|----------|----------|----------|----------|
| | | 4 | | | 5 | | | 6 | | | 7 | | | 8 | | | 9 | | | 10 | | |
| | | Combined Appliance Input Rating in Thousands of Btu per Hour | | | | | | | | | | | | | | | | | | | | |
| Vent Height H (ft) | | FAN +FAN | FAN +NAT | NAT +NAT | FAN +FAN | FAN +NAT | NAT +NAT | FAN +FAN | FAN +NAT | NAT +NAT | FAN +FAN | FAN +NAT | NAT +NAT | FAN +FAN | FAN +NAT | NAT +NAT | FAN +FAN | FAN +NAT | NAT +NAT | FAN +FAN | FAN +NAT | NAT +NAT |
| | | 6 | | 92 | 81 | 65 | 140 | 116 | 103 | 204 | 161 | 147 | 309 | 248 | 200 | 404 | 314 | 260 | 547 | 434 | 335 | 672 |
| 8 | | 101 | 90 | 73 | 155 | 129 | 114 | 224 | 178 | 163 | 339 | 275 | 223 | 444 | 348 | 290 | 602 | 480 | 378 | 740 | 577 | 465 |
| 10 | | 110 | 97 | 79 | 169 | 141 | 124 | 243 | 194 | 178 | 367 | 299 | 242 | 477 | 377 | 315 | 649 | 522 | 405 | 800 | 627 | 495 |
| 15 | | 125 | 112 | 91 | 195 | 164 | 144 | 283 | 228 | 206 | 427 | 352 | 280 | 556 | 444 | 365 | 753 | 612 | 465 | 924 | 733 | 565 |
| 20 | | 136 | 123 | 102 | 215 | 183 | 160 | 314 | 255 | 229 | 475 | 394 | 310 | 621 | 499 | 405 | 842 | 688 | 523 | 1035 | 826 | 640 |
| 30 | | 152 | 138 | 118 | 244 | 210 | 185 | 361 | 297 | 266 | 547 | 459 | 360 | 720 | 585 | 470 | 979 | 808 | 605 | 1209 | 975 | 740 |
| 50 | | 167 | 153 | 134 | 279 | 244 | 214 | 421 | 353 | 310 | 641 | 547 | 423 | 854 | 706 | 550 | 1164 | 977 | 705 | 1451 | 1188 | 860 |
| 100 | | 175 | 163 | NA | 311 | 277 | NA | 489 | 421 | NA | 751 | 658 | 479 | 1025 | 873 | 625 | 1408 | 1215 | 800 | 1784 | 1502 | 975 |

(continues)

Table 13.2(a) Continued

| | | Number of Appliances: Two or More | | | | | | | | | | | | | | | | | | | | |
|-------------------------|-----------------------|------------------------------------------------------------|------|------|-----|------|------|-----|------|------|-----|------|------|-----|------|------|-----|------|------|-----|------|------|
| | | Appliance Type: Category I | | | | | | | | | | | | | | | | | | | | |
| | | Appliance Vent Connection: Type B Double-Wall Connector | | | | | | | | | | | | | | | | | | | | |
| Vent Connector Capacity | | Type B Double-Wall Vent and Connector Diameter — D (in.) | | | | | | | | | | | | | | | | | | | | |
| | | 12 | | | 14 | | | 16 | | | 18 | | | 20 | | | 22 | | | 24 | | |
| Vent Height H (ft) | Connector Rise R (ft) | Appliance Input Rating Limits in Thousands of Btu per Hour | | | | | | | | | | | | | | | | | | | | |
| | | FAN | | NAT | FAN | | NAT | FAN | | NAT | FAN | | NAT | FAN | | NAT | FAN | | NAT | FAN | | NAT |
| | | Min | Max | Max | Min | Max | Max | Min | Max | Max | Min | Max | Max | Min | Max | Max | Min | Max | Max | Min | Max | Max |
| 6 | 2 | 174 | 764 | 496 | 223 | 1046 | 653 | 281 | 1371 | 853 | 346 | 1772 | 1080 | NA | NA | NA | NA | NA | NA | NA | NA | NA |
| | 4 | 180 | 897 | 616 | 230 | 1231 | 827 | 287 | 1617 | 1081 | 352 | 2069 | 1370 | NA | NA | NA | NA | NA | NA | NA | NA | NA |
| | 6 | NA | NA | NA | NA | NA | NA | NA | NA | NA | NA | NA | NA | NA | NA | NA | NA | NA | NA | NA | NA | NA |
| 8 | 2 | 186 | 822 | 516 | 238 | 1126 | 696 | 298 | 1478 | 910 | 365 | 1920 | 1150 | NA | NA | NA | NA | NA | NA | NA | NA | NA |
| | 4 | 192 | 952 | 644 | 244 | 1307 | 884 | 305 | 1719 | 1150 | 372 | 2211 | 1460 | 471 | 2737 | 1800 | 560 | 3319 | 2180 | 662 | 3957 | 2590 |
| | 6 | 198 | 1050 | 772 | 252 | 1445 | 1072 | 313 | 1902 | 1390 | 380 | 2434 | 1770 | 478 | 3018 | 2180 | 568 | 3665 | 2640 | 669 | 4373 | 3130 |
| 10 | 2 | 196 | 870 | 536 | 249 | 1195 | 730 | 311 | 1570 | 955 | 379 | 2049 | 1205 | NA | NA | NA | NA | NA | NA | NA | NA | NA |
| | 4 | 201 | 997 | 664 | 256 | 1371 | 924 | 318 | 1804 | 1205 | 387 | 2332 | 1535 | 486 | 2887 | 1890 | 581 | 3502 | 2280 | 686 | 4175 | 2710 |
| | 6 | 207 | 1095 | 792 | 263 | 1509 | 1118 | 325 | 1989 | 1455 | 395 | 2556 | 1865 | 494 | 3169 | 2290 | 589 | 3849 | 2760 | 694 | 4593 | 3270 |
| 15 | 2 | 214 | 967 | 568 | 272 | 1334 | 790 | 336 | 1760 | 1030 | 408 | 2317 | 1305 | NA | NA | NA | NA | NA | NA | NA | NA | NA |
| | 4 | 221 | 1085 | 712 | 279 | 1499 | 1006 | 344 | 1978 | 1320 | 416 | 2579 | 1665 | 523 | 3197 | 2060 | 624 | 3881 | 2490 | 734 | 4631 | 2960 |
| | 6 | 228 | 1181 | 856 | 286 | 1632 | 1222 | 351 | 2157 | 1610 | 424 | 2796 | 2025 | 533 | 3470 | 2510 | 634 | 4216 | 3030 | 743 | 5035 | 3600 |
| 20 | 2 | 223 | 1051 | 596 | 291 | 1443 | 840 | 357 | 1911 | 1095 | 430 | 2533 | 1385 | NA | NA | NA | NA | NA | NA | NA | NA | NA |
| | 4 | 230 | 1162 | 748 | 298 | 1597 | 1064 | 365 | 2116 | 1395 | 438 | 2778 | 1765 | 554 | 3447 | 2180 | 661 | 4190 | 2630 | 772 | 5005 | 3130 |
| | 6 | 237 | 1253 | 900 | 307 | 1726 | 1288 | 373 | 2287 | 1695 | 450 | 2984 | 2145 | 567 | 3708 | 2650 | 671 | 4511 | 3190 | 785 | 5392 | 3790 |
| 30 | 2 | 216 | 1217 | 632 | 286 | 1664 | 910 | 367 | 2183 | 1190 | 461 | 2891 | 1540 | NA | NA | NA | NA | NA | NA | NA | NA | NA |
| | 4 | 223 | 1316 | 792 | 294 | 1802 | 1160 | 376 | 2366 | 1510 | 474 | 3110 | 1920 | 619 | 3840 | 2365 | 728 | 4861 | 2860 | 847 | 5606 | 3410 |
| | 6 | 231 | 1400 | 952 | 303 | 1920 | 1410 | 384 | 2524 | 1830 | 485 | 3299 | 2340 | 632 | 4080 | 2875 | 741 | 4976 | 3480 | 860 | 5961 | 4150 |
| 50 | 2 | 206 | 1479 | 689 | 273 | 2023 | 1007 | 350 | 2659 | 1315 | 435 | 3548 | 1665 | NA | NA | NA | NA | NA | NA | NA | NA | NA |
| | 4 | 213 | 1561 | 860 | 281 | 2139 | 1291 | 359 | 2814 | 1685 | 447 | 3730 | 2135 | 580 | 4601 | 2633 | 709 | 5569 | 3185 | 851 | 6633 | 3790 |
| | 6 | 221 | 1631 | 1031 | 290 | 2242 | 1575 | 369 | 2951 | 2055 | 461 | 3893 | 2605 | 594 | 4808 | 3208 | 724 | 5826 | 3885 | 867 | 6943 | 4620 |
| 100 | 2 | 192 | 1923 | 712 | 254 | 2644 | 1050 | 326 | 3490 | 1370 | 402 | 4707 | 1740 | NA | NA | NA | NA | NA | NA | NA | NA | NA |
| | 4 | 200 | 1984 | 888 | 263 | 2731 | 1346 | 336 | 3606 | 1760 | 414 | 4842 | 2220 | 523 | 5982 | 2750 | 639 | 7254 | 3330 | 769 | 8650 | 3950 |
| | 6 | 208 | 2035 | 1064 | 272 | 2811 | 1642 | 346 | 3714 | 2150 | 426 | 4968 | 2700 | 539 | 6143 | 3350 | 654 | 7453 | 4070 | 786 | 8892 | 4810 |

| Common Vent Capacity | | Type B Double-Wall Common Vent Diameter — D (in.) | | | | | | | | | | | | | | | | | | | | |
|----------------------|------|--------------------------------------------------------------|----------|----------|----------|----------|----------|----------|----------|----------|----------|----------|----------|----------|----------|----------|----------|----------|----------|----------|----------|----------|
| | | 12 | | | 14 | | | 16 | | | 18 | | | 20 | | | 22 | | | 24 | | |
| Vent Height H (ft) | | Combined Appliance Input Rating in Thousands of Btu per Hour | | | | | | | | | | | | | | | | | | | | |
| | | FAN +FAN | FAN +NAT | NAT +NAT | FAN +FAN | FAN +NAT | NAT +NAT | FAN +FAN | FAN +NAT | NAT +NAT | FAN +FAN | FAN +NAT | NAT +NAT | FAN +FAN | FAN +NAT | NAT +NAT | FAN +FAN | FAN +NAT | NAT +NAT | FAN +FAN | FAN +NAT | NAT +NAT |
| | | 6 | 900 | 696 | 588 | 1284 | 990 | 815 | 1735 | 1336 | 1065 | 2253 | 1732 | 1345 | 2838 | 2180 | 1660 | 3488 | 2677 | 1970 | 4206 | 3226 |
| 8 | 994 | 773 | 652 | 1423 | 1103 | 912 | 1927 | 1491 | 1190 | 2507 | 1936 | 1510 | 3162 | 2439 | 1860 | 3890 | 2998 | 2200 | 4695 | 3616 | 2680 | |
| 10 | 1076 | 841 | 712 | 1542 | 1200 | 995 | 2093 | 1625 | 1300 | 2727 | 2113 | 1645 | 3444 | 2665 | 2030 | 4241 | 3278 | 2400 | 5123 | 3957 | 2920 | |
| 15 | 1247 | 986 | 825 | 1794 | 1410 | 1158 | 2440 | 1910 | 1510 | 3184 | 2484 | 1910 | 4026 | 3133 | 2360 | 4971 | 3862 | 2790 | 6016 | 4670 | 3400 | |
| 20 | 1405 | 1116 | 916 | 2006 | 1588 | 1290 | 2722 | 2147 | 1690 | 3561 | 2798 | 2140 | 4548 | 3552 | 2640 | 5573 | 4352 | 3120 | 6749 | 5261 | 3800 | |
| 30 | 1658 | 1327 | 1025 | 2373 | 1892 | 1525 | 3220 | 2558 | 1990 | 4197 | 3326 | 2520 | 5303 | 4193 | 3110 | 6539 | 5157 | 3680 | 7940 | 6247 | 4480 | |
| 50 | 2024 | 1640 | 1280 | 2911 | 2347 | 1863 | 3964 | 3183 | 2430 | 5184 | 4149 | 3075 | 6567 | 5240 | 3800 | 8116 | 6458 | 4500 | 9837 | 7813 | 5475 | |
| 100 | 2569 | 2131 | 1670 | 3732 | 3076 | 2450 | 5125 | 4202 | 3200 | 6749 | 5509 | 4050 | 8597 | 6986 | 5000 | 10,681 | 8648 | 5920 | 13,004 | 10,499 | 7200 | |

For SI units, 1 in. = 25.4 mm, 1 in.² = 645 mm², 1 ft = 0.305 m, 1000 Btu/hr = 0.293 kW.

Table 13.2(b) Type B Double-Wall Vent

| | | Number of Appliances: Two or More | | | | | | | | | | | | | | | | | | | | | | | |
|---------------------------|------------------------------|------------------------------------------------------------|-----|-----|-----|-----|-----|-----|-----|-----|-----|-----|-----|-----|-----|-----|-----|-----|-----|-----|------|-----|-----|------|-----|
| | | Appliance Type: Category I | | | | | | | | | | | | | | | | | | | | | | | |
| | | Appliance Vent Connection: Single-Wall Metal Connector | | | | | | | | | | | | | | | | | | | | | | | |
| Vent Connector Capacity | | | | | | | | | | | | | | | | | | | | | | | | | |
| | | Single-Wall Metal Vent Connector Diameter — <i>D</i> (in.) | | | | | | | | | | | | | | | | | | | | | | | |
| | | 3 | | | 4 | | | 5 | | | 6 | | | 7 | | | 8 | | | 9 | | | 10 | | |
| Vent Height <i>H</i> (ft) | Connector Rise <i>R</i> (ft) | Appliance Input Rating Limits in Thousands of Btu per Hour | | | | | | | | | | | | | | | | | | | | | | | |
| | | FAN | | NAT | FAN | | NAT | FAN | | NAT | FAN | | NAT | FAN | | NAT | FAN | | NAT | FAN | | NAT | FAN | | NAT |
| | | Min | Max | Max | Min | Max | Max | Min | Max | Max | Min | Max | Max | Min | Max | Max | Min | Max | Max | Min | Max | Max | Min | Max | Max |
| 6 | 1 | NA | NA | 26 | NA | NA | 46 | NA | NA | 71 | NA | NA | 102 | 207 | 223 | 140 | 262 | 293 | 183 | 325 | 373 | 234 | 447 | 463 | 286 |
| | 2 | NA | NA | 31 | NA | NA | 55 | NA | NA | 85 | 168 | 182 | 123 | 215 | 251 | 167 | 271 | 331 | 219 | 334 | 422 | 281 | 458 | 524 | 344 |
| | 3 | NA | NA | 34 | NA | NA | 62 | 121 | 131 | 95 | 175 | 198 | 138 | 222 | 273 | 188 | 279 | 361 | 247 | 344 | 462 | 316 | 468 | 574 | 385 |
| 8 | 1 | NA | NA | 27 | NA | NA | 48 | NA | NA | 75 | NA | NA | 106 | 226 | 240 | 145 | 285 | 316 | 191 | 352 | 403 | 244 | 481 | 502 | 299 |
| | 2 | NA | NA | 32 | NA | NA | 57 | 125 | 126 | 89 | 184 | 193 | 127 | 234 | 266 | 173 | 293 | 353 | 228 | 360 | 450 | 292 | 492 | 560 | 355 |
| | 3 | NA | NA | 35 | NA | NA | 64 | 130 | 138 | 100 | 191 | 208 | 144 | 241 | 287 | 197 | 302 | 381 | 256 | 370 | 489 | 328 | 501 | 609 | 400 |
| 10 | 1 | NA | NA | 28 | NA | NA | 50 | 119 | 121 | 77 | 182 | 186 | 110 | 240 | 253 | 150 | 302 | 335 | 196 | 372 | 429 | 252 | 506 | 534 | 308 |
| | 2 | NA | NA | 33 | 84 | 85 | 59 | 124 | 134 | 91 | 189 | 203 | 132 | 248 | 278 | 183 | 311 | 369 | 235 | 381 | 473 | 302 | 517 | 589 | 368 |
| | 3 | NA | NA | 36 | 89 | 91 | 67 | 129 | 144 | 102 | 197 | 217 | 148 | 257 | 299 | 203 | 320 | 398 | 265 | 391 | 511 | 339 | 528 | 637 | 413 |
| 15 | 1 | NA | NA | 29 | 79 | 87 | 52 | 116 | 138 | 81 | 177 | 214 | 116 | 238 | 291 | 158 | 312 | 380 | 208 | 397 | 482 | 266 | 556 | 596 | 324 |
| | 2 | NA | NA | 34 | 83 | 94 | 62 | 121 | 150 | 97 | 185 | 230 | 138 | 246 | 314 | 189 | 321 | 411 | 248 | 407 | 522 | 317 | 568 | 646 | 387 |
| | 3 | NA | NA | 39 | 87 | 100 | 70 | 127 | 160 | 109 | 193 | 243 | 157 | 255 | 333 | 215 | 331 | 438 | 281 | 418 | 557 | 360 | 579 | 690 | 437 |
| 20 | 1 | 49 | 56 | 30 | 78 | 97 | 54 | 115 | 152 | 84 | 175 | 238 | 120 | 233 | 325 | 165 | 306 | 425 | 217 | 390 | 538 | 276 | 546 | 664 | 336 |
| | 2 | 52 | 59 | 36 | 82 | 103 | 64 | 120 | 163 | 101 | 182 | 252 | 144 | 243 | 346 | 197 | 317 | 453 | 259 | 400 | 574 | 331 | 558 | 709 | 403 |
| | 3 | 55 | 62 | 40 | 87 | 107 | 72 | 125 | 172 | 113 | 190 | 264 | 164 | 252 | 363 | 223 | 326 | 476 | 294 | 412 | 607 | 375 | 570 | 750 | 457 |
| 30 | 1 | 47 | 60 | 31 | 77 | 110 | 57 | 112 | 175 | 89 | 169 | 278 | 129 | 226 | 380 | 175 | 296 | 497 | 230 | 378 | 630 | 294 | 528 | 779 | 358 |
| | 2 | 51 | 62 | 37 | 81 | 115 | 67 | 117 | 185 | 106 | 177 | 290 | 152 | 236 | 397 | 208 | 307 | 521 | 274 | 389 | 662 | 349 | 541 | 819 | 425 |
| | 3 | 54 | 64 | 42 | 85 | 119 | 76 | 122 | 193 | 120 | 185 | 300 | 172 | 244 | 412 | 235 | 316 | 542 | 309 | 400 | 690 | 394 | 555 | 855 | 482 |
| 50 | 1 | 46 | 69 | 34 | 75 | 128 | 60 | 109 | 207 | 96 | 162 | 336 | 137 | 217 | 460 | 188 | 284 | 604 | 245 | 364 | 768 | 314 | 507 | 951 | 384 |
| | 2 | 49 | 71 | 40 | 79 | 132 | 72 | 114 | 215 | 113 | 170 | 345 | 164 | 226 | 473 | 223 | 294 | 623 | 293 | 376 | 793 | 375 | 520 | 983 | 458 |
| | 3 | 52 | 72 | 45 | 83 | 136 | 82 | 119 | 221 | 123 | 178 | 353 | 186 | 235 | 486 | 252 | 304 | 640 | 331 | 387 | 816 | 423 | 535 | 1013 | 518 |
| 100 | 1 | 45 | 79 | 34 | 71 | 150 | 61 | 104 | 249 | 98 | 153 | 424 | 140 | 205 | 585 | 192 | 269 | 774 | 249 | 345 | 993 | 321 | 476 | 1236 | 393 |
| | 2 | 48 | 80 | 41 | 75 | 153 | 73 | 110 | 255 | 115 | 160 | 428 | 167 | 212 | 593 | 228 | 279 | 788 | 299 | 358 | 1011 | 383 | 490 | 1259 | 469 |
| | 3 | 51 | 81 | 46 | 79 | 157 | 85 | 114 | 260 | 129 | 168 | 433 | 190 | 222 | 603 | 256 | 289 | 801 | 339 | 368 | 1027 | 431 | 506 | 1280 | 527 |

Common Vent Capacity

| | | Type B Double-Wall Vent Diameter — <i>D</i> (in.) | | | | | | | | | | | | | | | | | | | | | | | |
|---------------------------|-----|--------------------------------------------------------------|-----|----------|----------|----------|-----|----------|----------|----------|-----|----------|----------|----------|-----|----------|----------|----------|------|----------|----------|----------|-----|----------|----------|
| | | 4 | | | 5 | | | 6 | | | 7 | | | 8 | | | 9 | | | 10 | | | | | |
| Vent Height <i>H</i> (ft) | | Combined Appliance Input Rating in Thousands of Btu per Hour | | | | | | | | | | | | | | | | | | | | | | | |
| | | FAN +FAN | | FAN +NAT | NAT +NAT | FAN +FAN | | FAN +NAT | NAT +NAT | FAN +FAN | | FAN +NAT | NAT +NAT | FAN +FAN | | FAN +NAT | NAT +NAT | FAN +FAN | | FAN +NAT | NAT +NAT | FAN +FAN | | FAN +NAT | NAT +NAT |
| | | FAN | FAN | FAN | NAT | FAN | FAN | FAN | NAT | FAN | FAN | FAN | NAT | FAN | FAN | FAN | NAT | FAN | FAN | FAN | NAT | FAN | FAN | FAN | NAT |
| 6 | NA | 78 | 64 | NA | 113 | 99 | 200 | 158 | 144 | 304 | 244 | 196 | 398 | 310 | 257 | 541 | 429 | 332 | 665 | 515 | 407 | | | | |
| 8 | NA | 87 | 71 | NA | 126 | 111 | 218 | 173 | 159 | 331 | 269 | 218 | 436 | 342 | 285 | 592 | 473 | 373 | 730 | 569 | 460 | | | | |
| 10 | NA | 94 | 76 | 163 | 137 | 120 | 237 | 189 | 174 | 357 | 292 | 236 | 467 | 369 | 309 | 638 | 512 | 398 | 787 | 617 | 487 | | | | |
| 15 | 121 | 108 | 88 | 189 | 159 | 140 | 275 | 221 | 200 | 416 | 343 | 274 | 544 | 434 | 357 | 738 | 599 | 456 | 905 | 718 | 553 | | | | |
| 20 | 131 | 118 | 98 | 208 | 177 | 156 | 305 | 247 | 223 | 463 | 383 | 302 | 606 | 487 | 395 | 824 | 673 | 512 | 1013 | 808 | 626 | | | | |
| 30 | 145 | 132 | 113 | 236 | 202 | 180 | 350 | 286 | 257 | 533 | 446 | 349 | 703 | 570 | 459 | 958 | 790 | 593 | 1183 | 952 | 723 | | | | |
| 50 | 159 | 145 | 128 | 268 | 233 | 208 | 406 | 337 | 296 | 622 | 529 | 410 | 833 | 686 | 535 | 1139 | 954 | 689 | 1418 | 1157 | 838 | | | | |
| 100 | 166 | 153 | NA | 297 | 263 | NA | 469 | 398 | NA | 726 | 633 | 464 | 999 | 846 | 606 | 1378 | 1185 | 780 | 1741 | 1459 | 948 | | | | |

For SI units, 1 in. = 25.4 mm, 1 in.² = 645 mm², 1 ft = 0.305 m, 1000 Btu/hr = 0.293 kW.

Table 13.2(c) Masonry Chimney

| Vent Connector Capacity | | Type B Double-Wall Vent Connector Diameter — D (in.) | | | | | | | | | | | | | | | | | | | | | | | |
|-------------------------|-----------------------|------------------------------------------------------------|-----|-----|-----|-----|-----|-----|-----|-----|-----|-----|-----|-----|-----|-----|-----|-----|-----|-----|------|-----|-----|------|-----|
| | | 3 | | | 4 | | | 5 | | | 6 | | | 7 | | | 8 | | | 9 | | | 10 | | |
| | | Appliance Input Rating Limits in Thousands of Btu per Hour | | | | | | | | | | | | | | | | | | | | | | | |
| Vent Height H (ft) | Connector Rise R (ft) | FAN | | NAT | FAN | | NAT | FAN | | NAT | FAN | | NAT | FAN | | NAT | FAN | | NAT | FAN | | NAT | FAN | | NAT |
| | | Min | Max | Max | Min | Max | Max | Min | Max | Max | Min | Max | Max | Min | Max | Max | Min | Max | Max | Min | Max | Max | Min | Max | Max |
| 6 | 1 | 24 | 33 | 21 | 39 | 62 | 40 | 52 | 106 | 67 | 65 | 194 | 101 | 87 | 274 | 141 | 104 | 370 | 201 | 124 | 479 | 253 | 145 | 599 | 319 |
| | 2 | 26 | 43 | 28 | 41 | 79 | 52 | 53 | 133 | 85 | 67 | 230 | 124 | 89 | 324 | 173 | 107 | 436 | 232 | 127 | 562 | 300 | 148 | 694 | 378 |
| | 3 | 27 | 49 | 34 | 42 | 92 | 61 | 55 | 155 | 97 | 69 | 262 | 143 | 91 | 369 | 203 | 109 | 491 | 270 | 129 | 633 | 349 | 151 | 795 | 439 |
| 8 | 1 | 24 | 39 | 22 | 39 | 72 | 41 | 55 | 117 | 69 | 71 | 213 | 105 | 94 | 304 | 148 | 113 | 414 | 210 | 134 | 539 | 267 | 156 | 682 | 335 |
| | 2 | 26 | 47 | 29 | 40 | 87 | 53 | 57 | 140 | 86 | 73 | 246 | 127 | 97 | 350 | 179 | 116 | 473 | 240 | 137 | 615 | 311 | 160 | 776 | 394 |
| | 3 | 27 | 52 | 34 | 42 | 97 | 62 | 59 | 159 | 98 | 75 | 269 | 145 | 99 | 383 | 206 | 119 | 517 | 276 | 139 | 672 | 358 | 163 | 848 | 452 |
| 10 | 1 | 24 | 42 | 22 | 38 | 80 | 42 | 55 | 130 | 71 | 74 | 232 | 108 | 101 | 324 | 153 | 120 | 444 | 216 | 142 | 582 | 277 | 165 | 739 | 348 |
| | 2 | 26 | 50 | 29 | 40 | 93 | 54 | 57 | 153 | 87 | 76 | 261 | 129 | 103 | 366 | 184 | 123 | 498 | 247 | 145 | 652 | 321 | 168 | 825 | 407 |
| | 3 | 27 | 55 | 35 | 41 | 105 | 63 | 58 | 170 | 100 | 78 | 284 | 148 | 106 | 397 | 209 | 126 | 540 | 281 | 147 | 705 | 366 | 171 | 893 | 463 |
| 15 | 1 | 24 | 48 | 23 | 38 | 93 | 44 | 54 | 154 | 74 | 72 | 277 | 114 | 100 | 384 | 164 | 125 | 511 | 229 | 153 | 658 | 297 | 184 | 824 | 375 |
| | 2 | 25 | 55 | 31 | 39 | 105 | 55 | 56 | 174 | 89 | 74 | 299 | 134 | 103 | 419 | 192 | 128 | 558 | 260 | 156 | 718 | 339 | 187 | 900 | 432 |
| | 3 | 26 | 59 | 35 | 41 | 115 | 64 | 57 | 189 | 102 | 76 | 319 | 153 | 105 | 448 | 215 | 131 | 597 | 292 | 159 | 760 | 382 | 190 | 960 | 486 |
| 20 | 1 | 24 | 52 | 24 | 37 | 102 | 46 | 53 | 172 | 77 | 71 | 313 | 119 | 98 | 437 | 173 | 123 | 584 | 239 | 150 | 752 | 312 | 180 | 943 | 397 |
| | 2 | 25 | 58 | 31 | 39 | 114 | 56 | 55 | 190 | 91 | 73 | 335 | 138 | 101 | 467 | 199 | 126 | 625 | 270 | 153 | 805 | 354 | 184 | 1011 | 452 |
| | 3 | 26 | 63 | 35 | 40 | 123 | 65 | 57 | 204 | 104 | 75 | 353 | 157 | 104 | 493 | 222 | 129 | 661 | 301 | 156 | 851 | 396 | 187 | 1067 | 505 |
| 30 | 1 | 24 | 54 | 25 | 37 | 111 | 48 | 52 | 192 | 82 | 69 | 357 | 127 | 96 | 504 | 187 | 119 | 680 | 255 | 145 | 883 | 337 | 175 | 1115 | 432 |
| | 2 | 25 | 60 | 32 | 38 | 122 | 58 | 54 | 208 | 95 | 72 | 376 | 145 | 99 | 531 | 209 | 122 | 715 | 287 | 149 | 928 | 378 | 179 | 1171 | 484 |
| | 3 | 26 | 64 | 36 | 40 | 131 | 66 | 56 | 221 | 107 | 74 | 392 | 163 | 101 | 554 | 233 | 125 | 746 | 317 | 152 | 968 | 418 | 182 | 1220 | 535 |
| 50 | 1 | 23 | 51 | 25 | 36 | 116 | 51 | 51 | 209 | 89 | 67 | 405 | 143 | 92 | 582 | 213 | 115 | 798 | 294 | 140 | 1049 | 392 | 168 | 1334 | 506 |
| | 2 | 24 | 59 | 32 | 37 | 127 | 61 | 53 | 225 | 102 | 70 | 421 | 161 | 95 | 604 | 235 | 118 | 827 | 326 | 143 | 1085 | 433 | 172 | 1379 | 558 |
| | 3 | 26 | 64 | 36 | 39 | 135 | 69 | 55 | 237 | 115 | 72 | 435 | 180 | 98 | 624 | 260 | 121 | 854 | 357 | 147 | 1118 | 474 | 176 | 1421 | 611 |
| 100 | 1 | 23 | 46 | 24 | 35 | 108 | 50 | 49 | 208 | 92 | 65 | 428 | 155 | 88 | 640 | 237 | 109 | 907 | 334 | 134 | 1222 | 454 | 161 | 1589 | 596 |
| | 2 | 24 | 53 | 31 | 37 | 120 | 60 | 51 | 224 | 105 | 67 | 444 | 174 | 92 | 660 | 260 | 113 | 933 | 368 | 138 | 1253 | 497 | 165 | 1626 | 651 |
| | 3 | 25 | 59 | 35 | 38 | 130 | 68 | 53 | 237 | 118 | 69 | 458 | 193 | 94 | 679 | 285 | 116 | 956 | 399 | 141 | 1282 | 540 | 169 | 1661 | 705 |

| Common Vent Capacity | | Minimum Internal Area of Masonry Chimney Flue (in. ²) | | | | | | | | | | | | | | | | | | | | | | | |
|----------------------|----|-------------------------------------------------------------------|------|------|------|------|------|------|------|------|------|------|------|------|------|------|------|------|------|------|------|------|------|------|------|
| | | 12 | | | 19 | | | 28 | | | 38 | | | 50 | | | 63 | | | 78 | | | 113 | | |
| | | Combined Appliance Input Rating in Thousands of Btu per Hour | | | | | | | | | | | | | | | | | | | | | | | |
| Vent Height H (ft) | | FAN | | NAT | FAN | | NAT | FAN | | NAT | FAN | | NAT | FAN | | NAT | FAN | | NAT | FAN | | NAT | FAN | | NAT |
| | | FAN +FAN | +NAT | +NAT | +FAN | +NAT | +NAT | +FAN | +NAT | +NAT | +FAN | +NAT | +NAT | +FAN | +NAT | +NAT | +FAN | +NAT | +NAT | +FAN | +NAT | +NAT | +FAN | +FAN | +NAT |
| 6 | NA | 74 | 25 | NA | 119 | 46 | NA | 178 | 71 | NA | 257 | 103 | NA | 351 | 143 | NA | 458 | 188 | NA | 582 | 246 | 1041 | 853 | NA | |
| 8 | NA | 80 | 28 | NA | 130 | 53 | NA | 193 | 82 | NA | 279 | 119 | NA | 384 | 163 | NA | 501 | 218 | 724 | 636 | 278 | 1144 | 937 | 408 | |
| 10 | NA | 84 | 31 | NA | 138 | 56 | NA | 207 | 90 | NA | 299 | 131 | NA | 409 | 177 | 606 | 538 | 236 | 776 | 686 | 302 | 1226 | 1010 | 454 | |
| 15 | NA | NA | 36 | NA | 152 | 67 | NA | 233 | 106 | NA | 334 | 152 | 523 | 467 | 212 | 682 | 611 | 283 | 874 | 781 | 365 | 1374 | 1156 | 546 | |
| 20 | NA | NA | 41 | NA | NA | 75 | NA | 250 | 122 | NA | 368 | 172 | 565 | 508 | 243 | 742 | 668 | 325 | 955 | 858 | 419 | 1513 | 1286 | 648 | |
| 30 | NA | NA | NA | NA | NA | NA | NA | 270 | 137 | NA | 404 | 198 | 615 | 564 | 278 | 816 | 747 | 381 | 1062 | 969 | 496 | 1702 | 1473 | 749 | |
| 50 | NA | NA | NA | NA | NA | NA | NA | NA | NA | NA | NA | NA | NA | 620 | 328 | 879 | 831 | 461 | 1165 | 1089 | 606 | 1905 | 1692 | 922 | |
| 100 | NA | NA | NA | NA | NA | NA | NA | NA | NA | NA | NA | NA | NA | NA | 348 | NA | NA | 499 | NA | NA | 669 | 2053 | 1921 | 1058 | |

For SI units, 1 in. = 25.4 mm, 1 in.² = 645 mm², 1 ft = 0.305 m, 1000 Btu/hr = 0.293 kW.

Table 13.2(d) Masonry Chimney

| | | Number of Appliances: Two or More | | | | | | | | | | | | | | | | | | | | | | | |
|-------------------------|-----------------------|------------------------------------------------------------|-----|-----|-----|-----|-----|-----|-----|-----|-----|-----|-----|-----|-----|-----|-----|-----|-----|-----|------|-----|-----|------|-----|
| | | Appliance Type: Category I | | | | | | | | | | | | | | | | | | | | | | | |
| | | Appliance Vent Connection: Single-Wall Metal Connector | | | | | | | | | | | | | | | | | | | | | | | |
| Vent Connector Capacity | | Single-Wall Metal Vent Connector Diameter — D (in.) | | | | | | | | | | | | | | | | | | | | | | | |
| | | 3 | | | 4 | | | 5 | | | 6 | | | 7 | | | 8 | | | 9 | | | 10 | | |
| Vent Height H (ft) | Connector Rise R (ft) | Appliance Input Rating Limits in Thousands of Btu per Hour | | | | | | | | | | | | | | | | | | | | | | | |
| | | FAN | | NAT | FAN | | NAT | FAN | | NAT | FAN | | NAT | FAN | | NAT | FAN | | NAT | FAN | | NAT | FAN | | NAT |
| | | Min | Max | Max | Min | Max | Max | Min | Max | Max | Min | Max | Max | Min | Max | Max | Min | Max | Max | Min | Max | Max | Min | Max | Max |
| 6 | 1 | NA | NA | 21 | NA | NA | 39 | NA | NA | 66 | 179 | 191 | 100 | 231 | 271 | 140 | 292 | 366 | 200 | 362 | 474 | 252 | 499 | 594 | 316 |
| | 2 | NA | NA | 28 | NA | NA | 52 | NA | NA | 84 | 186 | 227 | 123 | 239 | 321 | 172 | 301 | 432 | 231 | 373 | 557 | 299 | 509 | 696 | 376 |
| | 3 | NA | NA | 34 | NA | NA | 61 | 134 | 153 | 97 | 193 | 258 | 142 | 247 | 365 | 202 | 309 | 491 | 269 | 381 | 634 | 348 | 519 | 793 | 437 |
| 8 | 1 | NA | NA | 21 | NA | NA | 40 | NA | NA | 68 | 195 | 208 | 103 | 250 | 298 | 146 | 313 | 407 | 207 | 387 | 530 | 263 | 529 | 672 | 331 |
| | 2 | NA | NA | 28 | NA | NA | 52 | 137 | 139 | 85 | 202 | 240 | 125 | 258 | 343 | 177 | 323 | 465 | 238 | 397 | 607 | 309 | 540 | 766 | 391 |
| | 3 | NA | NA | 34 | NA | NA | 62 | 143 | 156 | 98 | 210 | 264 | 145 | 266 | 376 | 205 | 332 | 509 | 274 | 407 | 663 | 356 | 551 | 838 | 450 |
| 10 | 1 | NA | NA | 22 | NA | NA | 41 | 130 | 151 | 70 | 202 | 225 | 106 | 267 | 316 | 151 | 333 | 434 | 213 | 410 | 571 | 273 | 558 | 727 | 343 |
| | 2 | NA | NA | 29 | NA | NA | 53 | 136 | 150 | 86 | 210 | 255 | 128 | 276 | 358 | 181 | 343 | 489 | 244 | 420 | 640 | 317 | 569 | 813 | 403 |
| | 3 | NA | NA | 34 | 97 | 102 | 62 | 143 | 166 | 99 | 217 | 277 | 147 | 284 | 389 | 207 | 352 | 530 | 279 | 430 | 694 | 363 | 580 | 880 | 459 |
| 15 | 1 | NA | NA | 23 | NA | NA | 43 | 129 | 151 | 73 | 199 | 271 | 112 | 268 | 376 | 161 | 349 | 502 | 225 | 445 | 646 | 291 | 623 | 808 | 366 |
| | 2 | NA | NA | 30 | 92 | 103 | 54 | 135 | 170 | 88 | 207 | 295 | 132 | 277 | 411 | 189 | 359 | 548 | 256 | 456 | 706 | 334 | 634 | 884 | 424 |
| | 3 | NA | NA | 34 | 96 | 112 | 63 | 141 | 185 | 101 | 215 | 315 | 151 | 286 | 439 | 213 | 368 | 586 | 289 | 466 | 755 | 378 | 646 | 945 | 479 |
| 20 | 1 | NA | NA | 23 | 87 | 99 | 45 | 128 | 167 | 76 | 197 | 303 | 117 | 265 | 425 | 169 | 345 | 569 | 235 | 439 | 734 | 306 | 614 | 921 | 387 |
| | 2 | NA | NA | 30 | 91 | 111 | 55 | 134 | 185 | 90 | 205 | 325 | 136 | 274 | 455 | 195 | 355 | 610 | 266 | 450 | 787 | 348 | 627 | 986 | 443 |
| | 3 | NA | NA | 35 | 96 | 119 | 64 | 140 | 199 | 103 | 213 | 343 | 154 | 282 | 481 | 219 | 365 | 644 | 298 | 461 | 831 | 391 | 639 | 1042 | 496 |
| 30 | 1 | NA | NA | 24 | 86 | 108 | 47 | 126 | 187 | 80 | 193 | 347 | 124 | 259 | 492 | 183 | 338 | 665 | 250 | 430 | 864 | 330 | 600 | 1089 | 421 |
| | 2 | NA | NA | 31 | 91 | 119 | 57 | 132 | 203 | 93 | 201 | 366 | 142 | 269 | 518 | 205 | 348 | 699 | 282 | 442 | 908 | 372 | 613 | 1145 | 473 |
| | 3 | NA | NA | 35 | 95 | 127 | 65 | 138 | 216 | 105 | 209 | 381 | 160 | 277 | 540 | 229 | 358 | 729 | 312 | 452 | 946 | 412 | 626 | 1193 | 524 |
| 50 | 1 | NA | NA | 24 | 85 | 113 | 50 | 124 | 204 | 87 | 188 | 392 | 139 | 252 | 567 | 208 | 328 | 778 | 287 | 417 | 1022 | 383 | 582 | 1302 | 492 |
| | 2 | NA | NA | 31 | 89 | 123 | 60 | 130 | 218 | 100 | 196 | 408 | 158 | 262 | 588 | 230 | 339 | 806 | 320 | 429 | 1058 | 425 | 596 | 1346 | 545 |
| | 3 | NA | NA | 35 | 94 | 131 | 68 | 136 | 231 | 112 | 205 | 422 | 176 | 271 | 607 | 255 | 349 | 831 | 351 | 440 | 1090 | 466 | 610 | 1386 | 597 |
| 100 | 1 | NA | NA | 23 | 84 | 104 | 49 | 122 | 200 | 89 | 182 | 410 | 151 | 243 | 617 | 232 | 315 | 875 | 328 | 402 | 1181 | 444 | 560 | 1537 | 580 |
| | 2 | NA | NA | 30 | 88 | 115 | 59 | 127 | 215 | 102 | 190 | 425 | 169 | 253 | 636 | 254 | 326 | 899 | 361 | 415 | 1210 | 488 | 575 | 1570 | 634 |
| | 3 | NA | NA | 34 | 93 | 124 | 67 | 133 | 228 | 115 | 199 | 438 | 188 | 262 | 654 | 279 | 337 | 921 | 392 | 427 | 1238 | 529 | 589 | 1604 | 687 |

| Common Vent Capacity | | Minimum Internal Area of Masonry Chimney Flue (in. ²) | | | | | | | | | | | | | | | | | | | | | | | |
|----------------------|--|-------------------------------------------------------------------|----------|----------|----------|----------|----------|----------|----------|----------|----------|----------|----------|----------|----------|----------|----------|----------|----------|----------|----------|----------|----------|----------|----------|
| | | 12 | | | 19 | | | 28 | | | 38 | | | 50 | | | 63 | | | 78 | | | 113 | | |
| Vent Height H (ft) | | Combined Appliance Input Rating in Thousands of Btu per Hour | | | | | | | | | | | | | | | | | | | | | | | |
| | | FAN +FAN | FAN +NAT | NAT +NAT | FAN +FAN | FAN +NAT | NAT +NAT | FAN +FAN | FAN +NAT | NAT +NAT | FAN +FAN | FAN +NAT | NAT +NAT | FAN +FAN | FAN +NAT | NAT +NAT | FAN +FAN | FAN +NAT | NAT +NAT | FAN +FAN | FAN +NAT | NAT +NAT | FAN +FAN | FAN +FAN | NAT +NAT |
| 6 | | NA | NA | 25 | NA | 118 | 45 | NA | 176 | 71 | NA | 255 | 102 | NA | 348 | 142 | NA | 455 | 187 | NA | 579 | 245 | NA | 846 | NA |
| 8 | | NA | NA | 28 | NA | 128 | 52 | NA | 190 | 81 | NA | 276 | 118 | NA | 380 | 162 | NA | 497 | 217 | NA | 633 | 277 | 1136 | 928 | 405 |
| 10 | | NA | NA | 31 | NA | 136 | 56 | NA | 205 | 89 | NA | 295 | 129 | NA | 405 | 175 | NA | 532 | 234 | 771 | 680 | 300 | 1216 | 1000 | 450 |
| 15 | | NA | NA | 36 | NA | NA | 66 | NA | 230 | 105 | NA | 335 | 150 | NA | 400 | 210 | 677 | 602 | 280 | 866 | 772 | 360 | 1359 | 1139 | 540 |
| 20 | | NA | NA | NA | NA | NA | 74 | NA | 247 | 120 | NA | 362 | 170 | NA | 503 | 240 | 765 | 661 | 321 | 947 | 849 | 415 | 1495 | 1264 | 640 |
| 30 | | NA | NA | NA | NA | NA | NA | NA | NA | 135 | NA | 398 | 195 | NA | 558 | 275 | 808 | 739 | 377 | 1052 | 957 | 490 | 1682 | 1447 | 740 |
| 50 | | NA | NA | NA | NA | NA | NA | NA | NA | NA | NA | NA | NA | NA | 612 | 325 | NA | 821 | 456 | 1152 | 1076 | 600 | 1879 | 1672 | 910 |
| 100 | | NA | NA | NA | NA | NA | NA | NA | NA | NA | NA | NA | NA | NA | NA | NA | NA | NA | 494 | NA | NA | 663 | 2006 | 1885 | 1046 |

For SI units, 1 in. = 25.4 mm, 1 in.² = 645 mm², 1 ft = 0.305 m, 1000 Btu/hr = 0.293 kW.

Table 13.2(e) Single-Wall Metal Pipe or Type B Asbestos Cement Vent

| | | Number of Appliances: | | Two or More | | | |
|--------------------------------------------------------------|----------------------------------|-------------------------------------|-----|------------------------|-----|-----|------|
| | | Appliance Type: | | Draft Hood-Equipped | | | |
| | | Appliance Vent Connection: | | Direct to Pipe or Vent | | | |
| Vent Connector Capacity | | | | | | | |
| Total Vent Height H (ft) | Connector Rise R (ft) | Vent Connector Diameter — D (in.) | | | | | |
| | | 3 | 4 | 5 | 6 | 7 | 8 |
| Maximum Appliance Input Rating in Thousands of Btu per Hour | | | | | | | |
| 6–8 | 1 | 21 | 40 | 68 | 102 | 146 | 205 |
| | 2 | 28 | 53 | 86 | 124 | 178 | 235 |
| | 3 | 34 | 61 | 98 | 147 | 204 | 275 |
| 15 | 1 | 23 | 44 | 77 | 117 | 179 | 240 |
| | 2 | 30 | 56 | 92 | 134 | 194 | 265 |
| | 3 | 35 | 64 | 102 | 155 | 216 | 298 |
| 30 and up | 1 | 25 | 49 | 84 | 129 | 190 | 270 |
| | 2 | 31 | 58 | 97 | 145 | 211 | 295 |
| | 3 | 36 | 68 | 107 | 164 | 232 | 321 |
| Common Vent Capacity | | | | | | | |
| Total Vent Height H (ft) | Common Vent Diameter — D (in.) | | | | | | |
| | 4 | 5 | 6 | 7 | 8 | 10 | 12 |
| Combined Appliance Input Rating in Thousands of Btu per Hour | | | | | | | |
| 6 | 48 | 78 | 111 | 155 | 205 | 320 | NA |
| 8 | 55 | 89 | 128 | 175 | 234 | 365 | 505 |
| 10 | 59 | 95 | 136 | 190 | 250 | 395 | 560 |
| 15 | 71 | 115 | 168 | 228 | 305 | 480 | 690 |
| 20 | 80 | 129 | 186 | 260 | 340 | 550 | 790 |
| 30 | NA | 147 | 215 | 300 | 400 | 650 | 940 |
| 50 | NA | NA | NA | 360 | 490 | 810 | 1190 |

For SI units, 1 in. = 25.4 mm, 1 in.² = 645 mm², 1 ft = 0.305 m, 1000 Btu/hr = 0.293 kW.

Note: See Figure F₁(f) and Section 13.2.

13.2.3 Vent Connector Exceeding Maximum Length. The vent connector shall be routed to the vent utilizing the shortest possible route. Connectors with longer horizontal lengths than those listed in Table 13.2.2 are permitted under the following conditions:

- (1) The maximum capacity (FAN Max or NAT Max) of the vent connector shall be reduced 10 percent for each additional multiple of the length listed in Table 13.2.2. For example, the maximum length listed for a 4 in. (100 mm) connector is 6 ft (1.8 m). With a connector length greater than 6 ft (1.8 m) but not exceeding 12 ft (3.7 m), the maximum capacity must be reduced by 10 percent (0.90 × maximum vent connector capacity). With a connector length greater than 12 ft (3.7 m) but not exceeding 18 ft (5.5 m), the maximum capacity must be reduced by 20 percent (0.80 × maximum vent capacity).
- (2) For a connector serving a fan-assisted appliance, the minimum capacity (FAN Min) of the connector shall be determined by referring to the corresponding single appliance table. For Type B double-wall connectors, Table 13.1(a)

shall be used. For single-wall connectors, Table 13.1(b) shall be used. The height (H) and lateral (L) shall be measured according to the procedures for a single appliance vent, as if the other appliances were not present.

13.2.4 Vent Connector Manifolds. Where the vent connectors are combined prior to entering the vertical portion of the common vent to form a common vent manifold, the size of the common vent manifold and the common vent shall be determined by applying a 10 percent reduction (0.90 × maximum common vent capacity) to the common vent capacity part of the common vent tables. The length of the common vent manifold (LM) shall not exceed 18 in./in. (18 mm/mm) of common vent diameter (D).

13.2.5 Vent Offsets. Where the common vertical vent is offset, the maximum capacity of the common vent shall be reduced in accordance with 13.2.6 and the horizontal length of the common vent offset shall not exceed 18 in./in. (18 mm/mm) of common vent diameter (D). Where multiple offsets occur in a common vent, the total horizontal length of all offsets

Table 13.2(f) Exterior Masonry Chimney

| | | Number of Appliances: | | Two or More | | | | |
|----------------------------------------------------------------------|----------------------------------------------|----------------------------|-----|------------------------------|-----|-----|-----|-----|
| | | Appliance Type: | | NAT + NAT | | | | |
| | | Appliance Vent Connection: | | Type B Double-Wall Connector | | | | |
| Combined Appliance Maximum Input Rating in Thousands of Btu per Hour | | | | | | | | |
| Vent Height <i>H</i> (ft) | Internal Area of Chimney (in. ²) | | | | | | | |
| | 12 | 19 | 28 | 38 | 50 | 63 | 78 | 113 |
| 6 | 25 | 46 | 71 | 103 | 143 | 188 | 246 | NA |
| 8 | 28 | 53 | 82 | 119 | 163 | 218 | 278 | 408 |
| 10 | 31 | 56 | 90 | 131 | 177 | 236 | 302 | 454 |
| 15 | NA | 67 | 106 | 152 | 212 | 283 | 365 | 546 |
| 20 | NA | NA | NA | NA | NA | 325 | 419 | 648 |
| 30 | NA | NA | NA | NA | NA | NA | 496 | 749 |
| 50 | NA | NA | NA | NA | NA | NA | NA | 922 |
| 100 | NA | NA | NA | NA | NA | NA | NA | NA |

For SI units, 1 in. = 25.4 mm, 1 in.² = 645 mm², 1 ft = 0.305 m, 1000 Btu/hr = 0.293 kW.

combined shall not exceed 18 in./in. (18 mm/mm) of the common vent diameter.

13.2.6 Elbows in Vents. For each elbow up to and including 45 degrees in the common vent, the maximum common vent capacity listed in the venting tables shall be reduced by 5 percent. For each elbow greater than 45 degrees up to and including 90 degrees, the maximum common vent capacity listed in the venting tables shall be reduced by 10 percent.

13.2.7 Elbows in Connectors. The vent connector capacities listed in the common vent sizing tables include allowance for two 90 degree elbows. For each additional elbow up to and including 45 degrees, the maximum vent connector capacity listed in the venting tables shall be reduced by 5 percent. For each elbow greater than 45 degrees up to and including 90 degrees, the maximum vent connector capacity listed in the venting tables shall be reduced by 10 percent.

13.2.8 Common Vent Minimum Size. The cross-sectional area of the common vent shall be equal to or greater than the cross-sectional area of the largest connector.

13.2.9 Tee and Wye Fittings. Tee and wye fittings connected to a common gas vent shall be considered as part of the common gas vent and constructed of materials consistent with that of the common gas vent.

13.2.10 Tee and Wye Sizing. At the point where tee or wye fittings connect to a common gas vent, the opening size of the fitting shall be equal to the size of the common vent. Such fittings shall not be prohibited from having reduced size openings at the point of connection of appliance gas vent connectors.

13.2.11 High-Altitude Installations. Sea level input ratings shall be used when determining maximum capacity for high-altitude installation. Actual input (derated for altitude) shall be used for determining minimum capacity for high-altitude installation.

13.2.12 Connector Rise. The connector rise (*R*) for each appliance connector shall be measured from the draft hood outlet or flue collar to the centerline where the vent gas streams come together.

13.2.13 Vent Height. For multiple appliances all located on one floor, available total height (*H*) shall be measured from the highest draft hood outlet or flue collar up to the level of the outlet of the common vent.

13.2.14 Multistory Vent Height. For multistory installations, available total height (*H*) for each segment of the system shall be the vertical distance between the highest draft hood outlet or flue collar entering that segment and the centerline of the next higher interconnection tee.

13.2.15 Multistory Lowest Vent and Vent Connector Sizing. The size of the lowest connector and of the vertical vent leading to the lowest interconnection of a multistory system shall be in accordance with Table 13.1(a) or Table 13.1(b) for available total height (*H*) up to the lowest interconnection.

13.2.16 Multistory B Vents Required. Where used in multistory systems, vertical common vents shall be Type B double wall and shall be installed with a listed vent cap.

13.2.17 Multistory Vent Offsets and Capacity. Offsets in multistory common vent systems shall be limited to a single offset in each system, and systems with an offset shall comply with all of the following:

- (1) The offset angle shall not exceed 45 degrees from vertical.
- (2) The horizontal length of the offset shall not exceed 18 in./in. (18 mm/mm) of common vent diameter of the segment in which the offset is located.
- (3) For the segment of the common vertical vent containing the offset, the common vent capacity listed in the common venting tables shall be reduced by 20 percent (0.80 × maximum common vent capacity).
- (4) A multistory common vent shall not be reduced in size above the offset.

13.2.18 Vertical Vent Size Limitation. Where two or more appliances are connected to a vertical vent or chimney, the flow area of the largest section of vertical vent or chimney shall not exceed seven times the smallest listed appliance categorized vent areas, flue collar area, or draft hood outlet area unless designed in accordance with approved engineering methods.

Table 13.2(g) Exterior Masonry Chimney

| | | Number of Appliances: | | Two or More | | | | |
|--------------------------------------------------------------------------------------------------|----------------------------------------------|----------------------------|----|------------------------------|----|-----|-----|-----|
| | | Appliance Type: | | NAT + NAT | | | | |
| | | Appliance Vent Connection: | | Type B Double-Wall Connector | | | | |
| Minimum Allowable Input Rating of Space-Heating Appliance in Thousands of Btu per Hour | | | | | | | | |
| Vent Height H (ft) | Internal Area of Chimney (in. ²) | | | | | | | |
| | 12 | 19 | 28 | 38 | 50 | 63 | 78 | 113 |
| Local 99% winter design temperature: 37°F or greater | | | | | | | | |
| 6 | 0 | 0 | 0 | 0 | 0 | 0 | 0 | NA |
| 8 | 0 | 0 | 0 | 0 | 0 | 0 | 0 | 0 |
| 10 | 0 | 0 | 0 | 0 | 0 | 0 | 0 | 0 |
| 15 | NA | 0 | 0 | 0 | 0 | 0 | 0 | 0 |
| 20 | NA | NA | NA | NA | NA | 184 | 0 | 0 |
| 30 | NA | NA | NA | NA | NA | 393 | 334 | 0 |
| 50 | NA | NA | NA | NA | NA | NA | NA | 579 |
| 100 | NA | NA | NA | NA | NA | NA | NA | NA |
| Local 99% winter design temperature: 27°F to 36°F | | | | | | | | |
| 6 | 0 | 0 | 68 | NA | NA | 180 | 212 | NA |
| 8 | 0 | 0 | 82 | NA | NA | 187 | 214 | 263 |
| 10 | 0 | 51 | NA | NA | NA | 201 | 225 | 265 |
| 15 | NA | NA | NA | NA | NA | 253 | 274 | 305 |
| 20 | NA | NA | NA | NA | NA | 307 | 330 | 362 |
| 30 | NA | NA | NA | NA | NA | NA | 445 | 485 |
| 50 | NA | NA | NA | NA | NA | NA | NA | 763 |
| 100 | NA | NA | NA | NA | NA | NA | NA | NA |
| Local 99% winter design temperature: 17°F to 26°F | | | | | | | | |
| 6 | NA | NA | NA | NA | NA | NA | NA | NA |
| 8 | NA | NA | NA | NA | NA | NA | 264 | 352 |
| 10 | NA | NA | NA | NA | NA | NA | 278 | 358 |
| 15 | NA | NA | NA | NA | NA | NA | 331 | 398 |
| 20 | NA | NA | NA | NA | NA | NA | 387 | 457 |
| 30 | NA | NA | NA | NA | NA | NA | NA | 581 |
| 50 | NA | NA | NA | NA | NA | NA | NA | 862 |
| 100 | NA | NA | NA | NA | NA | NA | NA | NA |
| Local 99% winter design temperature: 5°F to 16°F | | | | | | | | |
| 6 | NA | NA | NA | NA | NA | NA | NA | NA |
| 8 | NA | NA | NA | NA | NA | NA | NA | NA |
| 10 | NA | NA | NA | NA | NA | NA | NA | 430 |
| 15 | NA | NA | NA | NA | NA | NA | NA | 485 |
| 20 | NA | NA | NA | NA | NA | NA | NA | 547 |
| 30 | NA | NA | NA | NA | NA | NA | NA | 682 |
| 50 | NA | NA | NA | NA | NA | NA | NA | NA |
| 100 | NA | NA | NA | NA | NA | NA | NA | NA |
| Local 99% winter design temperature: 4°F or lower Not recommended for any vent configurations | | | | | | | | |

For SI units, 1 in. = 25.4 mm, 1 in.² = 645 mm², 1 ft = 0.305 m, 1000 Btu/hr = 0.293 kW, °C = (°F - 32)/1.8.

Note: See Figure F.2.4 for a map showing local 99 percent winter design temperatures in the United States.

Table 13.2(h) Exterior Masonry Chimney

| | | Number of Appliances: | | Two or More | | | | |
|----------------------------------------------------------------------|----------------------------------------------|----------------------------|-----|------------------------------|-----|-----|------|------|
| | | Appliance Type: | | FAN + NAT | | | | |
| | | Appliance Vent Connection: | | Type B Double-Wall Connector | | | | |
| Combined Appliance Maximum Input Rating in Thousands of Btu per Hour | | | | | | | | |
| Vent Height <i>H</i> (ft) | Internal Area of Chimney (in. ²) | | | | | | | |
| | 12 | 19 | 28 | 38 | 50 | 63 | 78 | 113 |
| 6 | 74 | 119 | 178 | 257 | 351 | 458 | 582 | 853 |
| 8 | 80 | 130 | 193 | 279 | 384 | 501 | 636 | 937 |
| 10 | 84 | 138 | 207 | 299 | 409 | 538 | 686 | 1010 |
| 15 | NA | 152 | 233 | 334 | 467 | 611 | 781 | 1156 |
| 20 | NA | NA | 250 | 368 | 508 | 668 | 858 | 1286 |
| 30 | NA | NA | NA | 404 | 564 | 747 | 969 | 1473 |
| 50 | NA | NA | NA | NA | NA | 831 | 1089 | 1692 |
| 100 | NA | NA | NA | NA | NA | NA | NA | 1921 |

For SI units, 1 in. = 25.4 mm, 1 in.² = 645 mm², 1 ft = 0.305 m, 1000 Btu/hr = 0.293 kW.

13.2.19 Two-Stage/Modulating Appliances. For appliances with more than one input rate, the minimum vent connector capacity (FAN Min) determined from the tables shall be less than the lowest appliance input rating, and the maximum vent connector capacity (FAN Max or NAT Max) determined from the tables shall be greater than the highest appliance input rating.

13.2.20* Corrugated Chimney Liners. Listed corrugated metallic chimney liner systems in masonry chimneys shall be sized by using Table 13.2(a) or Table 13.2(b) for Type B vents, with the maximum capacity reduced by 20 percent (0.80 × maximum capacity) and the minimum capacity as shown in Table 13.2(a) or Table 13.2(b). Corrugated metallic liner systems installed with bends or offsets shall have their maximum capacity further reduced in accordance with 13.2.5 and 13.2.6. The 20 percent reduction for corrugated metallic chimney liner systems includes an allowance for one long radius 90-degree turn at the bottom of the liner.

13.2.21 Connections to Chimney Liners. Where double-wall connectors are required, tee and wye fittings used to connect to the common vent chimney liner shall be listed double-wall fittings. Connections between chimney liners and listed double-wall fittings shall be made with listed adapter fittings designed for such purpose.

▲ 13.2.22 Chimneys and Vent Locations. Table 13.2(a) through Table 13.2(e) shall be used only for chimneys and vents not exposed to the outdoors below the roof line. A Type B vent or listed chimney lining system passing through an unused masonry chimney flue shall not be considered to be exposed to the outdoors. A Type B vent passing through an unventilated enclosure or chase insulated to a value of not less than R8 shall not be considered to be exposed to the outdoors. Where vents extend outdoors above the roof more than 5 ft (1.5 m) higher than required by Table 12.7.3, and where vents terminate in accordance with 12.7.3(1)(b), the outdoor portion of the vent shall be enclosed as required by this paragraph for vents not considered to be exposed to the outdoors, or such venting system shall be engineered. Table 13.2(f), Table 13.2(g), Table 13.2(h), and Table 13.2(i) shall be used for clay tile lined exterior masonry chimneys, provided all the following conditions are met:

- (1) The vent connector is Type B double wall.
- (2) At least one appliance is draft hood equipped.
- (3) The combined appliance input rating is less than the maximum capacity given by Table 13.2(f) (for NAT+NAT) or Table 13.2(h) (for FAN+NAT).
- (4) The input rating of each space-heating appliance is greater than the minimum input rating given by Table 13.2(g) (for NAT+NAT) or Table 13.2(i) (for FAN+NAT).
- (5) The vent connector sizing is in accordance with Table 13.2(c).

13.2.23 Draft Hood Conversion Accessories. Draft hood conversion accessories for use with masonry chimney venting listed Category I fan-assisted appliances shall be listed and installed in accordance with the listed accessory manufacturer's installation instructions.

13.2.24 Vent Connector Sizing. Vent connectors shall not be increased more than two sizes greater than the listed appliance categorized vent diameter, flue collar diameter, or draft hood outlet diameter. Vent connectors for draft hood-equipped appliances shall not be smaller than the draft hood outlet diameter. Where a vent connector size(s) determined from the tables for a fan-assisted appliance(s) is smaller than the flue collar diameter, the use of the smaller size(s) shall be permitted, provided that the installation complies with all of the following conditions:

- (1) Vent connectors for fan-assisted appliance flue collars 12 in. (300 mm) in diameter or smaller are not reduced by more than one table size [e.g., 12 in. to 10 in. (300 mm to 250 mm) is a one-size reduction], and those larger than 12 in. (300 mm) in diameter are not reduced more than two table sizes [e.g., 24 in. to 20 in. (610 mm to 510 mm) is a two-size reduction].
- (2) The fan-assisted appliance(s) is common vented with a draft hood-equipped appliance(s).
- (3) The vent connector has a smooth interior wall.

Table 13.2(i) Exterior Masonry Chimney

| | | Number of Appliances: | | Two or More | | | | | | |
|----------------------------------------------------------------------------------------------------|----------------------------------------------|----------------------------|-----|------------------------------|-----|-----|-----|------|--|--|
| | | Appliance Type: | | FAN + NAT | | | | | | |
| | | Appliance Vent Connection: | | Type B Double-Wall Connector | | | | | | |
| Minimum Allowable Input Rating of Space-Heating Appliance in Thousands of Btu per Hour | | | | | | | | | | |
| Vent Height <i>H</i> (ft) | Internal Area of Chimney (in. ²) | | | | | | | | | |
| | 12 | 19 | 28 | 38 | 50 | 63 | 78 | 113 | | |
| Local 99% winter design temperature: 37°F or greater | | | | | | | | | | |
| 6 | 0 | 0 | 0 | 0 | 0 | 0 | 0 | 0 | | |
| 8 | 0 | 0 | 0 | 0 | 0 | 0 | 0 | 0 | | |
| 10 | 0 | 0 | 0 | 0 | 0 | 0 | 0 | 0 | | |
| 15 | NA | 0 | 0 | 0 | 0 | 0 | 0 | 0 | | |
| 20 | NA | NA | 123 | 190 | 249 | 184 | 0 | 0 | | |
| 30 | NA | NA | NA | 334 | 398 | 393 | 334 | 0 | | |
| 50 | NA | NA | NA | NA | NA | 714 | 707 | 579 | | |
| 100 | NA | NA | NA | NA | NA | NA | NA | 1600 | | |
| Local 99% winter design temperature: 27°F to 36°F | | | | | | | | | | |
| 6 | 0 | 0 | 68 | 116 | 156 | 180 | 212 | 266 | | |
| 8 | 0 | 0 | 82 | 127 | 167 | 187 | 214 | 263 | | |
| 10 | 0 | 51 | 97 | 141 | 183 | 201 | 225 | 265 | | |
| 15 | NA | 111 | 142 | 183 | 233 | 253 | 274 | 305 | | |
| 20 | NA | NA | 187 | 230 | 284 | 307 | 330 | 362 | | |
| 30 | NA | NA | NA | 330 | 319 | 419 | 445 | 485 | | |
| 50 | NA | NA | NA | NA | NA | 672 | 705 | 763 | | |
| 100 | NA | NA | NA | NA | NA | NA | NA | 1554 | | |
| Local 99% winter design temperature: 17°F to 26°F | | | | | | | | | | |
| 6 | 0 | 55 | 99 | 141 | 182 | 215 | 259 | 349 | | |
| 8 | 52 | 74 | 111 | 154 | 197 | 226 | 264 | 352 | | |
| 10 | NA | 90 | 125 | 169 | 214 | 245 | 278 | 358 | | |
| 15 | NA | NA | 167 | 212 | 263 | 296 | 331 | 398 | | |
| 20 | NA | NA | 212 | 258 | 316 | 352 | 387 | 457 | | |
| 30 | NA | NA | NA | 362 | 429 | 470 | 507 | 581 | | |
| 50 | NA | NA | NA | NA | NA | 723 | 766 | 862 | | |
| 100 | NA | NA | NA | NA | NA | NA | NA | 1669 | | |
| Local 99% winter design temperature: 5°F to 16°F | | | | | | | | | | |
| 6 | NA | 78 | 121 | 166 | 214 | 252 | 301 | 416 | | |
| 8 | NA | 94 | 135 | 182 | 230 | 269 | 312 | 423 | | |
| 10 | NA | 111 | 149 | 198 | 250 | 289 | 331 | 430 | | |
| 15 | NA | NA | 193 | 247 | 305 | 346 | 393 | 485 | | |
| 20 | NA | NA | NA | 293 | 360 | 408 | 450 | 547 | | |
| 30 | NA | NA | NA | 377 | 450 | 531 | 580 | 682 | | |
| 50 | NA | NA | NA | NA | NA | 797 | 853 | 972 | | |
| 100 | NA | NA | NA | NA | NA | NA | NA | 1833 | | |
| Local 99% winter design temperature: -10°F to 4°F | | | | | | | | | | |
| 6 | NA | NA | 145 | 196 | 249 | 296 | 349 | 484 | | |
| 8 | NA | NA | 159 | 213 | 269 | 320 | 371 | 494 | | |
| 10 | NA | NA | 175 | 231 | 292 | 339 | 397 | 513 | | |
| 15 | NA | NA | NA | 283 | 351 | 404 | 457 | 586 | | |
| 20 | NA | NA | NA | 333 | 408 | 468 | 528 | 650 | | |
| 30 | NA | NA | NA | NA | NA | 603 | 667 | 805 | | |
| 50 | NA | NA | NA | NA | NA | NA | 955 | 1003 | | |
| 100 | NA | NA | NA | NA | NA | NA | NA | NA | | |
| Local 99% winter design temperature: -11°F or lower Not recommended for any vent configurations | | | | | | | | | | |

For SI units, 1 in. = 25.4 mm, 1 in.² = 645 mm², 1 ft = 0.305 m, 1000 Btu/hr = 0.293 kW.

Note: See Figure F_{2.4} for a map showing local 99 percent winter design temperatures in the United States.

13.2.25 Multiple Vent and Connector Sizes. All combinations of pipe sizes, single-wall metal pipe, and double-wall metal pipe shall be allowed within any connector run(s) or within the common vent, provided ALL of the appropriate tables permit ALL of the desired sizes and types of pipe, as if they were used for the entire length of the subject connector or vent. Where single-wall and Type B double-wall metal pipes are used for vent connectors within the same venting system, the common vent shall be sized using Table 13.2(b) or Table 13.2(d) as appropriate.

13.2.26 Multiple Vent and Connector Sizes Permitted. Where a Chapter 13 table permits more than one diameter of pipe to be used for a connector or vent, all the permitted sizes shall be permitted to be used.

13.2.27 Interpolation. Interpolation shall be permitted in calculating capacities for vent dimensions that fall between table entries.

13.2.28 Extrapolation. Extrapolation beyond the table entries shall not be permitted.

13.2.29 Sizing Vents Not Covered by Tables. For vent heights lower than 6 ft (1.8 m) and higher than shown in the tables, engineering methods shall be used to calculate vent capacities.

13.2.30 Height Entries. Where the actual height of a vent falls between entries in the height column of the applicable table in Table 13.2(a) through Table 13.2(i), either of the following shall be used:

- (1) Interpolation
- (2) The lower appliance input rating shown in the table entries, for FAN **Max** and NAT **Max** column values; and the higher appliance input rating for the FAN **Min** column values

Annex A Explanatory Material

Annex A is not a part of the requirements of this NFPA document but is included for informational purposes only. This annex contains explanatory material, numbered to correspond with the applicable text paragraphs.

Δ A.1.1.1.1(A) The final pressure regulator in an undiluted liquefied petroleum gas (LP-Gas) system can include any one of the following:

- (1) The second stage regulator or integral two-stage regulator
- (2) A 2 psi (14 kPa) service regulator or integral 2 psi (14 kPa) service regulator
- (3) A single-stage regulator, where single-stage systems are permitted by NFPA 58.

Δ A.3.2.1 Approved. The American Gas Association, American National Standards Institute, and the National Fire Protection Association do not approve, inspect, or certify any installations, procedures, appliances, equipment, or materials; nor do they approve or evaluate testing laboratories. In determining the acceptability of installations, procedures, appliances, equipment, or materials, the authority having jurisdiction may base acceptance on compliance with NFPA or other appropriate standards. In the absence of such standards, said authority may require evidence of proper installation, procedure, or use. The authority having jurisdiction may also refer to the listings or labeling practices (*see 3.2.4*) of an organization that is concerned with product evaluations and is thus in a position to determine compliance with AGA, ANSI, CSA, NFPA, or appropriate standards for the current production of listed items.

A.3.2.2 Authority Having Jurisdiction (AHJ). The phrase “authority having jurisdiction,” or its acronym AHJ, is used in NFPA documents in a broad manner, since jurisdictions and approval agencies vary, as do their responsibilities. Where public safety is primary, the authority having jurisdiction may be a federal, state, local, or other regional department or individual such as a fire chief; fire marshal; chief of a fire prevention bureau, labor department, or health department; building official; electrical inspector; or others having statutory authority. For insurance purposes, an insurance inspection department, rating bureau, or other insurance company representative may be the authority having jurisdiction. In many circumstances, the property owner or his or her designated agent assumes the role of the authority having jurisdiction; at government installations, the commanding officer or departmental official may be the authority having jurisdiction.

As used in the definition of Authority Having Jurisdiction, equipment includes appliances and materials.

A.3.2.3 Code. The decision to designate a standard as a “code” is based on such factors as the size and scope of the document, its intended use and form of adoption, and whether it contains substantial enforcement and administrative provisions.

A.3.2.5 Listed. The means for identifying listed appliances and equipment may vary for each organization concerned with product evaluation; some organizations do not recognize appliances and equipment as listed unless it is also labeled. The authority having jurisdiction should utilize the system employed by the listing organization to identify a listed product.

As used in the definition of Listed, equipment includes appliances and materials.

A.3.3.5.11.1 Category I Vented Appliance. For additional information on appliance categorization as shown in 3.3.5.11.1 through 3.3.5.11.4, see the appropriate Z21 and Z83 American National Standards.

A.3.3.53 Gas Vent. This definition does not apply to plastic plumbing piping that is specified as a venting material in the manufacturer's instructions for gas-fired appliances that are listed for venting with such piping.

A.3.3.64.1 Combustible (Material). Materials are considered to be combustible even if they have been fire-retardant treated.

N A.3.3.84.4 Monitor Regulator. A monitor regulator is part of a two-regulator set in which one regulator is doing the work (i.e., the working regulator) and the second regulator (i.e., the monitor) is installed to back up the working regulator should it fail. The monitor regulator remains in a nearly full-open position until it senses a rise in the downstream pressure. Each regulator senses the same downstream pressure, which allows either regulator to limit that downstream pressure.

A.3.3.95.7 Venting System. A venting system is usually composed of a vent or a chimney and vent connector(s), if used, assembled to form the open passageway.

A.4.4 The provisions of Section 4.4 do not require noncombustible materials to be tested in order to be classified as noncombustible materials. Materials such as steel, concrete, and cement blocks are generally accepted to be noncombustible.

A.5.4.1 The size of gas piping depends on the following factors:

- (1) Allowable loss in pressure from point of delivery to appliance
- (2) Maximum gas demand
- (3) Length of piping and number of fittings
- (4) Specific gravity of the gas
- (5) Diversity factor
- (6) Foreseeable future demand

A.5.4.2 To obtain the cubic feet per hour of gas required, divide the Btu per hour rating by the Btu per cubic foot heating value of the gas supplied. The heating value of the gas can be obtained from the local gas supplier.

Where the ratings of the appliances to be installed are not known, Table A.5.4.2.1 shows the approximate demand of typical appliances by types.

A.5.4.2.1 Some older appliances do not have a nameplate. In this case Table A.5.4.2.1 or an estimate of the appliance input should be used. The input can be based on the following:

- (1) A rating provided by the manufacturer
- (2) The rating of similar appliances
- (3) Recommendations of the gas supplier
- (4) Recommendations of a qualified agency
- (5) A gas flow test
- (6) Measurement of the orifice size of the appliance

The requirement of 5.4.1 that the piping system provide sufficient gas to each appliance inlet must be complied with.

A.5.4.3 The gas-carrying capacities for different sizes and lengths of iron pipe, or equivalent rigid pipe, and semirigid tubing are shown in the capacity tables in Chapter 6.

Table A.5.4.2.1 Approximate Gas Input for Typical Appliances

| Appliance | Input Btu/hr (Approx.) |
|----------------------------------------------------------|------------------------|
| Space Heating Units | |
| <i>Warm air furnace</i> | |
| Single family | 100,000 |
| Multifamily, per unit | 60,000 |
| <i>Hydronic boiler</i> | |
| Single family | 100,000 |
| Multifamily, per unit | 60,000 |
| Space and Water Heating Units | |
| <i>Hydronic boiler</i> | |
| Single family | 120,000 |
| Multifamily, per unit | 75,000 |
| <i>Water Heating Appliances</i> | |
| Water heater, automatic storage 30 gal to 40 gal tank | 35,000 |
| Water heater, automatic storage 50 gal tank | 50,000 |
| <i>Water heater, automatic instantaneous</i> | |
| Capacity at 2 gal/min | 142,800 |
| Capacity at 4 gal/min | 285,000 |
| Capacity at 6 gal/min | 428,400 |
| Water heater, domestic, circulating or side-arm | 35,000 |
| Cooking Appliances | |
| Range, freestanding, domestic | 65,000 |
| Built-in oven or broiler unit, domestic | 25,000 |
| Built-in top unit, domestic | 40,000 |
| Other Appliances | |
| Refrigerator | 3,000 |
| Clothes dryer, Type 1 (domestic) | 35,000 |
| Gas fireplace direct vent | 40,000 |
| Gas log | 80,000 |
| Barbecue | 40,000 |
| Gas light | 2,500 |

Table 6.2.1(a) through Table 6.2.1(x) indicate approximate capacities for single runs of piping. If the specific gravity of the gas is other than 0.60, correction factors should be applied. Correction factors for use with these tables are given in Table B.3.4.

For any gas piping system, for special appliances, or for conditions other than those covered by the capacity tables in Chapter 6, such as longer runs, greater gas demands, or greater pressure drops, the size of each gas piping system should be determined by the pipe sizing equations in Section 6.4 or by standard engineering methods acceptable to the authority having jurisdiction.

A suggested procedure for using the Chapter 6 tables to size a gas piping system is illustrated in Annex B.

A.5.5.4(1) For welding specifications and procedures that can be used, see the API STD 1104, *Welding of Pipelines and Related Facilities*; AWS B2.1/B2.1M, *Specification for Welding Procedure and Performance Qualification*; or ASME Boiler and Pressure Vessel Code, Section IX.

▲ **A.5.6** Table A.5.6 is a list of piping materials and fittings that are allowed in the Code.

A.5.6.2.3 An average of 0.3 grains of hydrogen sulfide per 100 scf of gas (0.7 mg/100 L) is equivalent to a trace as determined by ANSI/ASTM D2385, *Method of Test for Hydrogen Sulfide and Mercaptan Sulfur in Natural Gas (Cadmium Sulfate — Iodometric Titration Method)*, or ANSI/ASTM D2420, *Method of Test for Hydrogen Sulfide in Liquefied Petroleum (LP) Gases (Lead Acetate Method)*.

A.5.6.3.4 Copper and copper alloy tubing and fittings (except tin-lined copper tubing) should not be used if the gas contains more than an average of 0.3 grains of hydrogen sulfide per 100 scf of gas (0.7 mg/100 L).

A.5.6.4.2 The reference to ANSI/UL 651, *Schedule 40 and 80 Rigid PVC Conduit and Fittings*, is to require that PVC be a minimum of Schedule 40 and that it be resistant to the effects of ultraviolet light because it is likely to be exposed to the outdoors when used for regulator vents.

A.5.6.6.4 Joint sealing compounds are used in tapered pipe thread joints to provide lubrication to the joint as it is tightened so that less tightening torque is “used up” to overcome friction and also to provide a seal of the small leak paths that would otherwise remain in a metal-to-metal threaded joint.

Commonly used joint sealing compounds include pipe dope and polytetrafluoroethylene tape, also known as PTFE or Teflon® tape. Some pipe dopes also contain PTFE. Joint sealing compounds should be applied so that no sealing compound finds its way into the interior of a completed joint.

Pipe dope application should be made only to the male pipe thread of the joint and should coat all of the threads commencing one thread back from the end of the threaded pipe.

PTFE tape application should be made by wrapping the tape tightly around the male thread in a clockwise direction when viewed from the end of the pipe to which the tape is being applied. Tape application should wrap all of the threads commencing one thread back from the end of the threaded pipe.

A.5.6.7.1 For welding and brazing specifications and procedures that can be used, see API STD 1104, *Welding Pipelines and Related Facilities*; AWS B2.1/B2.1M, *Specification for Welding Procedure and Performance Qualification*; AWS B2.2/B2.2M, *Specification for Brazing Procedure and Performance Qualification*; or ASME Boiler and Pressure Vessel Code, Section IX.

A.5.7 This section applies to premises-owned meters.

A.5.8 This section applies to premises-owned regulators.

A.5.11 Appliances that can produce a vacuum or dangerous reduction in pressure include, but are not limited to, gas compressors.

A.6.1 Table A.6.1 provides nominal metric pipe size equivalents.

△ Table A.5.6 Pipe, Tube, Fittings, and Joints for Natural Gas and Liquefied Petroleum Gas Applications

| Pipe | | Fitting Types | | |
|--------------------------------------------------------------------------------------------------------|--------------------------------|-----------------------------------------------------------------------------------------------------------------------------------------------------------------------------------------|----------------------------------------------------------------------------------------------------|--------------------------------------------------------------------------|
| Material | Standard | Metallic Pipe | Joint Types | Other Requirements |
| Black Steel <i>Minimum Schedule 10</i> | ASTM A106/A106M* | Steel Malleable Iron Steel Cast Iron ANSI/ASME B16.1* Copper Alloy ANSI LC 4* Special Copper Alloy | Threaded Flanged Press Connect | 5.6.5, 5.6.6, 5.6.7, 5.6.7.5, 7.2.2, 7.12 |
| Galvanized Steel <i>Minimum Schedule 10</i> | ASTM A53/A53M* | | | |
| Wrought Iron <i>Minimum Schedule 10</i> <i>Also known as low iron</i> <i>or wrought steel</i> | ANSI/ASME B36.10M* | | | |
| Stainless Steel Minimum Schedule 10 | ASTM A312* | | | |
| Copper | None Specified | Cast Copper Alloy Copper Alloy Special | None Specified | 5.6.2.3, 5.6.2.4, 5.6.5, 5.6.6, 5.6.7, 5.6.7.2, 5.6.7.5, 7.12 |
| Copper Alloy (Brass) | None Specified | | | |
| Aluminum | ASTM B241/B241M* | Aluminum Special | None Specified | 5.6.2.4, 5.6.2.5, 5.6.3, 5.6.5, 5.6.6, 5.6.7, 5.6.7.5, 7.2.2, 7.12 |
| Metallic Tubing | | | | |
| Copper | ASTM B88* ASTM B280* | Cast Copper Alloy Wrought Copper ANSI LC4/CSA 6.32* Forged Copper Alloy Special | Brazed Flanged/Brazed Brazed Mechanically Pressed (Crimped) Flared Press Connect | 5.6.3, 5.6.3.4, 5.6.5, 5.6.7.1, 5.6.7.2, 7.2.2, 7.12 |
| CSST | ANSI LC 1/CSA 6.26* | ANSI LC 1/CSA 6.26* | Manufacturer's installation instructions Compression | 5.6.5, 7.2.2, 7.2.7, 7.12, 9.6.1(5) |
| Aluminum | ASTM B210* ASTM B241/B241M* | Copper Alloy (Brass) Special | | 5.6.5, 7.2.2, 7.12, 9.5.1.2, 9.6.1(2) |
| Steel | ASTM A254/A254M* | Special | | 5.6.3, 5.6.5, 5.6.7.5, 7.2.2, 7.12 |
| Stainless Steel | ASTM A268* ASTM A269* | Approved ANSI LC 4* | Welded Brazed Press Connect | 5.6.3, 5.6.5, 7.2.2, 7.12 |
| Non-Metallic Pipe | | | | |
| Polyethylene (PE) | ASTM D2513* | Polyethylene (PE) or Polyamide (PA) | Manufacturer's instructions | 5.6.5, 5.6.8, 7.1.7, 7.2.2 |
| Polyamide (PA) | ASTM F2945* | ASTM D2513* (Heat fusion) Service head adapters meeting Category I of ASTM D2513* Connections to Metallic Pipe meeting ASTM D2513*, ASTM F1973*, or ASTM F2509* | Compression-type mechanical joints Heat Fusion | |

*Required standard. See Annex K for standard title.

Table A.6.1 Nominal Pipe

| Nominal Pipe Diameter | |
|-----------------------|-----|
| in. | mm |
| 1/8 | 6 |
| 3/16 | 7 |
| 1/4 | 8 |
| 3/8 | 10 |
| 1/2 | 15 |
| 5/8 | 18 |
| 3/4 | 20 |
| 1 | 25 |
| 1 1/4 | 32 |
| 1 1/2 | 40 |
| 2 | 50 |
| 2 1/2 | 65 |
| 3 | 80 |
| 3 1/2 | 90 |
| 4 | 100 |
| 4 1/2 | 115 |
| 5 | 125 |
| 6 | 150 |
| 8 | 200 |
| 10 | 250 |
| 12 | 300 |

For pipe sizes >12 in. diam., use 1 in. = 25 mm.

A.6.1.1 The Longest Length Method is the traditional method used to determine the equivalent piping length L that is then used along with the pipe sizing tables to determine the appropriate pipe diameter size.

A.6.1.2 The Branch Length Method is an alternate sizing method that could permit slightly smaller pipe diameters in some segments of a piping system when compared with the Longest Length Method.

A.6.4.1 The Low-Pressure Formula is the standard flow formula located in Annex B but rearranged to solve for the pipe diameter.

A.6.4.2 The High-Pressure Formula is the standard flow formula located in Annex B but rearranged to solve for the pipe diameter.

A.7.1.3 For information on corrosion protection of underground pipe, see NACE SP0169, *Control of External Corrosion on Underground or Submerged Metallic Piping Systems*. Information on installation, maintenance, and corrosion protection might be available from the gas supplier.

A.7.1.4 The gas supplier can be consulted for recommendations.

Δ A.7.2.5 The intent is that gas piping, shutoff valves required by this code, and regulators be allowed to be installed in accessible portions of plenums, accessible ducts used to supply combustion and ventilation air in accordance with Section 9.3,

and accessible spaces between a fixed ceiling and dropped ceiling.

A.7.4.3 Only vertical chases are recognized by the coverage. It is believed that welded joints for a horizontal gas line would be preferable to a horizontal chase.

A.7.11.4 The mixing blower is acknowledged as a special case because of its inability to tolerate control valves or comparable restrictions between mixing blower(s) and burner(s). With these limitations, mixing blower installations are not required to utilize safety blowouts, backfire preventers, explosion heads, flame arresters, or automatic firechecks that introduce pressure losses.

Δ A.7.11.5.1 For information on venting of deflagrations, see NFPA 68.

A.7.11.5.4 Additional interlocks might be necessary for safe operation of appliances supplied by the gas-mixing machine.

A.7.11.6(1) Two basic methods are generally used. One calls for a separate firecheck at each burner, the other a firecheck at each group of burners. The second method is generally more practical if a system consists of many closely spaced burners.

An approved automatic firecheck should be installed as near as practical upstream from a flame arrester used for local protection where test burners or lighting torches are employed.

Δ A.7.12.2 The required bonding connection may be made from the piping to the electrical service equipment enclosure, to the grounded conductor at the electrical service, to the grounding electrode conductor (where of sufficient size), or directly to the grounding electrode. The bond may also be made to a lightning protection system grounding electrode (but not to down conductors) if the resulting length of the bonding conductor is shorter. Lightning protection grounding systems are bonded to the electrical service grounding electrodes, in accordance with NFPA 780, using a method to minimize impedance between the systems.

Listed clamps are manufactured to facilitate attachment of the bonding conductor to either a segment of rigid pipe or to a CSST-copper alloy fitting. Clamps should be installed to remain accessible when building construction is complete.

State and local laws can limit who can attach the bonding connection to the building grounding system.

The size of the bonding conductor, a 6 AWG copper wire, is a minimum size, and larger wire can be used. The requirement also permits conductors of different materials (of equivalent size) and both single wire and multi-strand.

N A.7.12.2.3 The maximum length of the bonding connection was established based on studies conducted by the Gas Technology Institute in Project Number 21323, *Validation of Installation Methods for CSST Gas Piping to Mitigate Indirect Lightning Related Damage*. The shortest practical length should always be used.

If the bonding jumper required would be longer than 75 ft (22 m), an additional grounding electrode can be installed to allow a bonding jumper that is 75 ft (22 m) or less.

A.7.12.4 This requirement does not preclude the bonding of metallic piping to a grounding system.

A.7.12.5 Section 4.14 of NFPA 780 requires that all grounding media, including underground metallic piping systems, be interconnected to provide a common ground potential. These underground piping systems are not permitted to be substituted for grounding electrodes but must be bonded to the lightning protection grounding system. Where galvanic corrosion is of concern, the bond may be made via a spark gap or gas discharge tube.

A.8.1.1 Because it is sometimes necessary to divide a piping system into test sections and install test heads, connecting piping, and other necessary appurtenances for testing, it is not required that the tie-in sections of pipe be pressure-tested. Tie-in connections, however, should be tested with a noncorrosive leak detection fluid after gas has been introduced and the pressure has been increased sufficiently to give some indications whether leaks exist.

The test procedure used should be capable of disclosing all leaks in the section being tested and should be selected after giving due consideration to the volumetric content of the section and to its location.

Under no circumstances should a valve in a line be used as a bulkhead between gas in one section of the piping system and test medium in an adjacent section, unless two valves are installed in series with a valved “telltale” located between these valves. A valve should not be subjected to the test pressure unless it can be determined that the valve, including the valve closing mechanism, is designed to safely withstand the test pressure.

▲ **A.8.1.1.7** Fuel gas piping operating above 125 psi should be cleaned in accordance with NFPA 56.

A.8.1.4.3 During pressure tests conducted over long periods of time, such as overnight, the effects of temperature on pressure should be considered. Temperature drops can cause a drop in pressure great enough to be indicated by the test gauge. These temperature drops can cause test evaluators to think that a leak exists in the piping system when in fact the pressure drop was caused by a decrease in the ambient temperature. See Example 5 in B.7.5.

A.8.2.3 See Annex C for a suggested method.

A.8.3 The process of purging gas piping that contains fuel gas or charging gas piping that contains air must be performed in a manner that will minimize the potential for a flammable mixture to be developed within the piping.

Natural gas and propane suppliers add a distinctive odor to their gas. Persons conducting purging operations should not rely upon their sense of smell. When a gas piping system is brought into service and unodorized gas is detected, the company supplying the gas should be contacted to inform it of the situation and to determine what action should be taken. (More information on odorization of fuel gas is available in the *National Fuel Gas Code Handbook*, “Fuel Gas Odorization” supplement.)

A.8.3.1 Subsection 8.3.1 describes the characteristics of gas piping systems that are required to be purged only to the outdoors. The criteria were selected to distinguish between piping systems located in industrial, large commercial, and large multifamily buildings from those located in light commercial and smaller residential buildings. The gas piping systems installed in industrial, large commercial and large

multifamily buildings are considered to be larger, more complex systems for the purposes of defining their purging requirements. Because of their larger pipe volumes or potential for higher flow rates, these systems require procedures to ensure that a large volume of fuel gas is not released to the indoors and that flammable mixtures do not occur within the piping itself. Installers of these complex systems deal with considerably more variables that can result in a higher potential for discharge of large gas volumes during purging operations.

Specific occupancy categories such as industrial, manufacturing, commercial and large multifamily were not included in the fuel gas code. United States building codes define these occupancies for the purpose of construction and safety requirements. There is no general relation between the occupancy types, as defined by the building codes, and the size of gas piping system to be installed in that occupancy. The gas piping size and operating pressure are based on the nature of the piping system and gas appliances to be installed and are not dependent upon a building’s occupancy type or classification.

A.8.3.1.2 It is recommended that the oxygen levels in the piping be monitored during the purging process to determine when sufficient inert gas has been introduced. The manufacturer’s instructions for monitoring instruments must be followed when performing purge operations.

A.8.3.1.4 Combustible gas indicators are available with different scales. For purging, it is necessary to use the percent gas in air scale and to follow the manufacturer’s operating instructions. The percent lower explosible limit (% LEL) scale should not be used because it is not relevant to purging.

Users should verify that the indicator will detect fuel gas in the absence of oxygen. Many combustible gas indicators will not indicate fuel gas concentration accurately if no oxygen is present.

A.8.3.2 The criteria were selected to describe typical gas piping systems located in light commercial and the smaller residential family buildings. Gas piping systems installed in these buildings are considered to be smaller and less complex systems for the purposes of defining their purging requirements. Installers have familiarity with purging these systems and the potential for discharge of large gas volumes during purging operations is low. Also see A.8.3.1.

A.8.3.2.1 Where small piping systems contain air and are purged to either the indoors or outdoors with fuel gas, a rapid and uninterrupted flow of fuel gas must be introduced into one end of the piping system and vented out of the other end so as to prevent the development of a combustible fuel–air mixture. Purging these systems can be done either using a source of ignition to ignite the fuel gas or by using a listed combustible gas detector that can detect the presence of fuel gas.

A.9.1.1 The American Gas Association, American National Standards Institute, Inc., and the National Fire Protection Association do not approve, inspect, or certify any installations, procedures, appliances, equipment, or materials; nor do they approve or evaluate testing laboratories. In determining acceptability of installations, procedures, appliances, equipment, or materials, the authority having jurisdiction can base acceptance on compliance with AGA, ANSI, CSA, or NFPA, or other appropriate standards. In the absence of such standards, said author-

ity can require evidence of proper installation, procedure, or use. The authority having jurisdiction can also refer to the listings or labeling practices of an organization concerned with product evaluations and is thus in a position to determine compliance with appropriate standards for the current production of listed items.

A.9.1.6 Halogenated hydrocarbons are particularly injurious and corrosive after contact with flames or hot surfaces.

A.9.1.24 Building envelope changes made under weatherization practices intended to reduce air infiltration and contractor activities, such as the replacement of whole windows and exterior doors and extensive exterior modifications, will reduce the amount of infiltration air and could impact the amount of combustion air that is available for existing appliance installations. Proper vent sizing and configuration is crucial to maintaining the required vent performance in structures that have reduced air infiltration.

A.9.3 Operation of exhaust fans, ventilation systems, clothes dryers, or fireplaces can create conditions requiring special attention to avoid unsatisfactory operation of installed appliances.

A.9.3.2.1 See Table A.9.3.2.1.

A.9.3.2.2 See Table A.9.3.2.2(a) and Table A.9.3.2.2(b).

A.9.3.2.3(1) See Figure A.9.3.2.3(1).

A.9.3.3.1(1) See Figure A.9.3.3.1(1)(a) and Figure A.9.3.3.1(1)(b).

A.9.3.3.1(2) See Figure A.9.3.3.1(2).

A.9.3.3.2 See Figure A.9.3.3.2.

A.9.6.1.5 The expansion and contraction of the heater and the vibration from the blower motor can lead to work hardening of the rigid pipe or semirigid metallic tubing, which can ultimately lead to fractures and leakage. Connectors for this type of heater should have adequate flexibility, temperature rating, and vibration resistance to accommodate the characteristics of the heater. Such flexible connectors for suspended heaters should meet the following criteria:

- (1) Be determined to be appropriate for the application
- (2) Be specified by the heater manufacturer
- (3) Be installed in accordance with the manufacturer's installation instructions

A.9.6.3 Laboratory burners, commonly called Bunsen burners, are a type of burner used in laboratories. The original Bunsen burner was invented by Robert Bunsen in 1852. The use of the term in NFPA 54 is intended to include all types of portable laboratory burners used in laboratories and educational facilities.

A.10.1.1 This chapter is applicable primarily to nonindustrial-type appliances and installations and, unless specifically indicated, does not apply to industrial appliances and installations.

For additional information concerning particular gas appliances and accessories, including industrial types, reference can be made to the standards listed in Chapter 2 and Annex K.

A.10.1.2 Also see prohibited installations in 10.6.1, 10.7.1, 10.8.2, 10.9.2, and 10.22.1.

Table A.9.3.2.1 Standard Method: Required Volume, All Appliances

| Appliance Input (Btu/hr) | Required Volume (ft ³) |
|-----------------------------|---------------------------------------|
| 5,000 | 250 |
| 10,000 | 500 |
| 15,000 | 750 |
| 20,000 | 1,000 |
| 25,000 | 1,250 |
| 30,000 | 1,500 |
| 35,000 | 1,750 |
| 40,000 | 2,000 |
| 45,000 | 2,250 |
| 50,000 | 2,500 |
| 55,000 | 2,750 |
| 60,000 | 3,000 |
| 65,000 | 3,250 |
| 70,000 | 3,500 |
| 75,000 | 3,750 |
| 80,000 | 4,000 |
| 85,000 | 4,250 |
| 90,000 | 4,500 |
| 95,000 | 4,750 |
| 100,000 | 5,000 |
| 105,000 | 5,250 |
| 110,000 | 5,500 |
| 115,000 | 5,750 |
| 120,000 | 6,000 |
| 125,000 | 6,250 |
| 130,000 | 6,500 |
| 135,000 | 6,750 |
| 140,000 | 7,000 |
| 145,000 | 7,250 |
| 150,000 | 7,500 |
| 160,000 | 8,000 |
| 170,000 | 8,500 |
| 180,000 | 9,000 |
| 190,000 | 9,500 |
| 200,000 | 10,000 |
| 210,000 | 10,500 |
| 220,000 | 11,000 |
| 230,000 | 11,500 |
| 240,000 | 12,000 |
| 250,000 | 12,500 |
| 260,000 | 13,000 |
| 270,000 | 13,500 |
| 280,000 | 14,000 |
| 290,000 | 14,500 |
| 300,000 | 15,000 |

For SI units, 1 ft³ = 0.028 m³, 1000 Btu/hr = 0.293 kW.

**Table A.9.3.2.2(a) Known Air Infiltration Rate Method:
Minimum Space Volume for Appliances Other than Fan-
Assisted for Specified Infiltration Rates (ACH)**

| Appliance Input (Btu/hr) | Space Volume (ft ³) | | |
|--------------------------------|---------------------------------|----------|----------|
| | 0.25 ACH | 0.30 ACH | 0.35 ACH |
| 5,000 | 420 | 350 | 300 |
| 10,000 | 840 | 700 | 600 |
| 15,000 | 1,260 | 1,050 | 900 |
| 20,000 | 1,680 | 1,400 | 1,200 |
| 25,000 | 2,100 | 1,750 | 1,500 |
| 30,000 | 2,520 | 2,100 | 1,800 |
| 35,000 | 2,940 | 2,450 | 2,100 |
| 40,000 | 3,360 | 2,800 | 2,400 |
| 45,000 | 3,780 | 3,150 | 2,700 |
| 50,000 | 4,200 | 3,500 | 3,000 |
| 55,000 | 4,620 | 3,850 | 3,300 |
| 60,000 | 5,040 | 4,200 | 3,600 |
| 65,000 | 5,460 | 4,550 | 3,900 |
| 70,000 | 5,880 | 4,900 | 4,200 |
| 75,000 | 6,300 | 5,250 | 4,500 |
| 80,000 | 6,720 | 5,600 | 4,800 |
| 85,000 | 7,140 | 5,950 | 5,100 |
| 90,000 | 7,560 | 6,300 | 5,400 |
| 95,000 | 7,980 | 6,650 | 5,700 |
| 100,000 | 8,400 | 7,000 | 6,000 |
| 105,000 | 8,820 | 7,350 | 6,300 |
| 110,000 | 9,240 | 7,700 | 6,600 |
| 115,000 | 9,660 | 8,050 | 6,900 |
| 120,000 | 10,080 | 8,400 | 7,200 |
| 125,000 | 10,500 | 8,750 | 7,500 |
| 130,000 | 10,920 | 9,100 | 7,800 |
| 135,000 | 11,340 | 9,450 | 8,100 |
| 140,000 | 11,760 | 9,800 | 8,400 |
| 145,000 | 12,180 | 10,150 | 8,700 |
| 150,000 | 12,600 | 10,500 | 9,000 |
| 160,000 | 13,440 | 11,200 | 9,600 |
| 170,000 | 14,280 | 11,900 | 10,200 |
| 180,000 | 15,120 | 12,600 | 10,800 |
| 190,000 | 15,960 | 13,300 | 11,400 |
| 200,000 | 16,800 | 14,000 | 12,000 |
| 210,000 | 17,640 | 14,700 | 12,600 |
| 220,000 | 18,480 | 15,400 | 13,200 |
| 230,000 | 19,320 | 16,100 | 13,800 |
| 240,000 | 20,160 | 16,800 | 14,400 |
| 250,000 | 21,000 | 17,500 | 15,000 |
| 260,000 | 21,840 | 18,200 | 15,600 |
| 270,000 | 22,680 | 18,900 | 16,200 |
| 280,000 | 23,520 | 19,600 | 16,800 |
| 290,000 | 24,360 | 20,300 | 17,400 |
| 300,000 | 25,200 | 21,000 | 18,000 |

For SI units, 1 ft³ = 0.028 m³, 1000 Btu/hr = 0.293 kW.

ACH: Air change per hour.

**Table A.9.3.2.2(b) Known Air Infiltration Rate Method:
Minimum Space Volume for Fan-Assisted Appliance, for
Specified Infiltration Rates (ACH)**

| Appliance Input (Btu/hr) | Required Volume (ft ³) | | |
|--------------------------------|------------------------------------|----------|----------|
| | 0.25 ACH | 0.30 ACH | 0.35 ACH |
| 5,000 | 300 | 250 | 214 |
| 10,000 | 600 | 500 | 429 |
| 15,000 | 900 | 750 | 643 |
| 20,000 | 1,200 | 1,000 | 857 |
| 25,000 | 1,500 | 1,250 | 1,071 |
| 30,000 | 1,800 | 1,500 | 1,286 |
| 35,000 | 2,100 | 1,750 | 1,500 |
| 40,000 | 2,400 | 2,000 | 1,714 |
| 45,000 | 2,700 | 2,250 | 1,929 |
| 50,000 | 3,000 | 2,500 | 2,143 |
| 55,000 | 3,300 | 2,750 | 2,357 |
| 60,000 | 3,600 | 3,000 | 2,571 |
| 65,000 | 3,900 | 3,250 | 2,786 |
| 70,000 | 4,200 | 3,500 | 3,000 |
| 75,000 | 4,500 | 3,750 | 3,214 |
| 80,000 | 4,800 | 4,000 | 3,429 |
| 85,000 | 5,100 | 4,250 | 3,643 |
| 90,000 | 5,400 | 4,500 | 3,857 |
| 95,000 | 5,700 | 4,750 | 4,071 |
| 100,000 | 6,000 | 5,000 | 4,286 |
| 105,000 | 6,300 | 5,250 | 4,500 |
| 110,000 | 6,600 | 5,500 | 4,714 |
| 115,000 | 6,900 | 5,750 | 4,929 |
| 120,000 | 7,200 | 6,000 | 5,143 |
| 125,000 | 7,500 | 6,250 | 5,357 |
| 130,000 | 7,800 | 6,500 | 5,571 |
| 135,000 | 8,100 | 6,750 | 5,786 |
| 140,000 | 8,400 | 7,000 | 6,000 |
| 145,000 | 8,700 | 7,250 | 6,214 |
| 150,000 | 9,000 | 7,500 | 6,429 |
| 160,000 | 9,600 | 8,000 | 6,857 |
| 170,000 | 10,200 | 8,500 | 7,286 |
| 180,000 | 10,800 | 9,000 | 7,714 |
| 190,000 | 11,400 | 9,500 | 8,143 |
| 200,000 | 12,000 | 10,000 | 8,571 |
| 210,000 | 12,600 | 10,500 | 9,000 |
| 220,000 | 13,200 | 11,000 | 9,429 |
| 230,000 | 13,800 | 11,500 | 9,857 |
| 240,000 | 14,400 | 12,000 | 10,286 |
| 250,000 | 15,000 | 12,500 | 10,714 |
| 260,000 | 15,600 | 13,000 | 11,143 |
| 270,000 | 16,200 | 13,500 | 11,571 |
| 280,000 | 16,800 | 14,000 | 12,000 |
| 290,000 | 17,400 | 14,500 | 12,429 |
| 300,000 | 18,000 | 15,000 | 12,857 |

For SI units, 1 ft³ = 0.028 m³, 1000 Btu/hr = 0.293 kW.

ACH: Air change per hour.

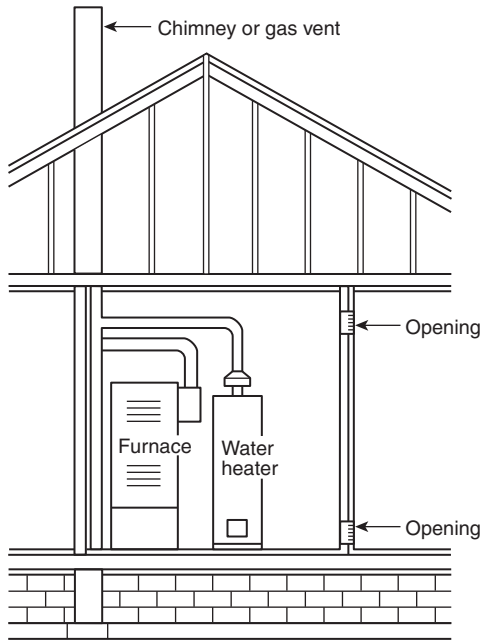

FIGURE A.9.3.2.3(1) All Combustion Air from Adjacent Indoor Spaces Through Indoor Combustion Air Openings.

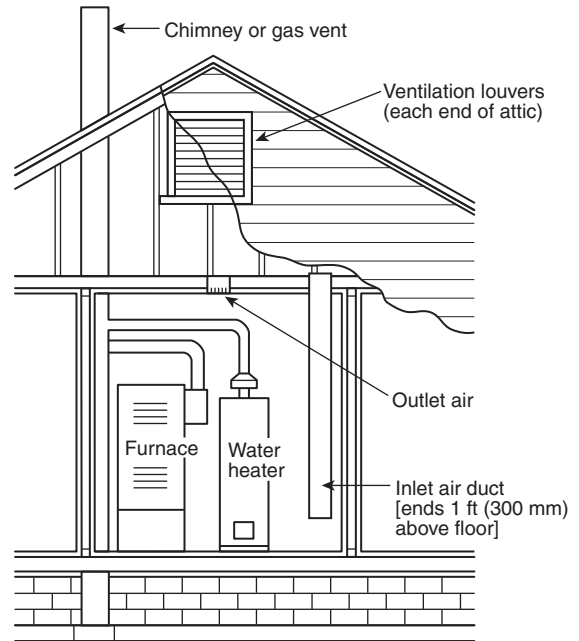

FIGURE A.9.3.3.1(1)(b) All Combustion Air from Outdoors Through Ventiladed Attic.

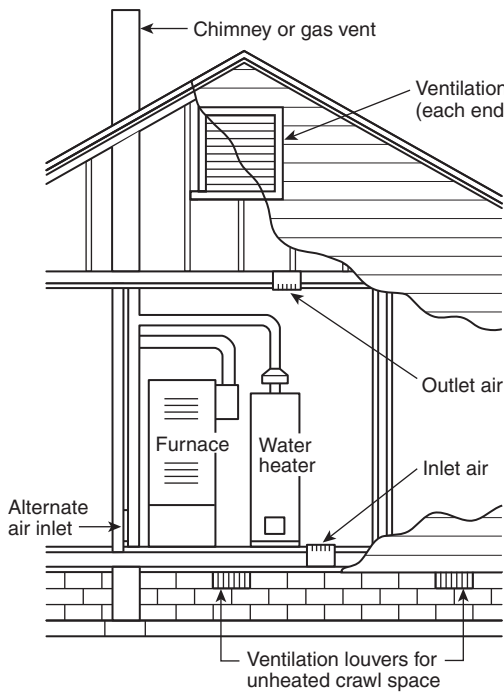

FIGURE A.9.3.3.1(1)(a) All Combustion Air from Outdoors — Inlet Air from Ventiladed Crawl Space and Outlet Air to Ventiladed Attic.

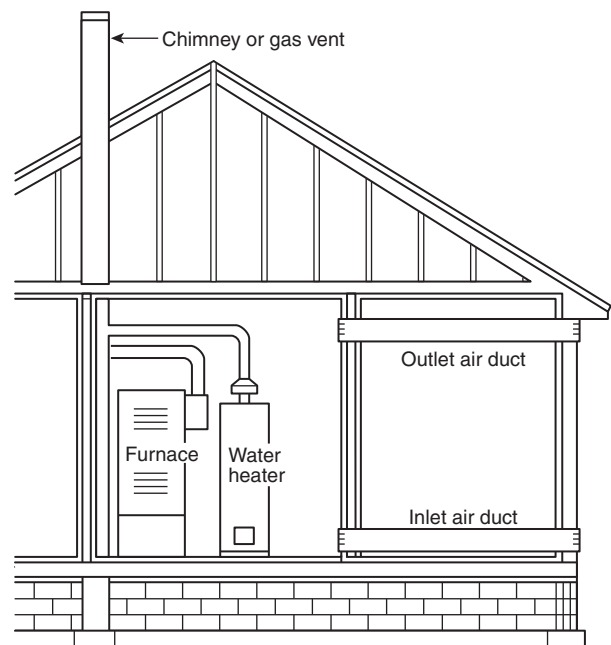

FIGURE A.9.3.3.1(2) All Combustion Air from Outdoors Through Horizontal Ducts.

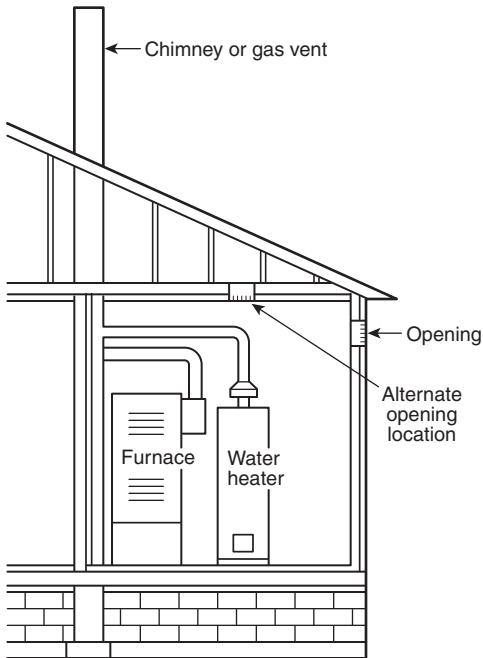

FIGURE A.9.3.3.2 All Combustion Air from Outdoors Through Single Combustion Air Opening.

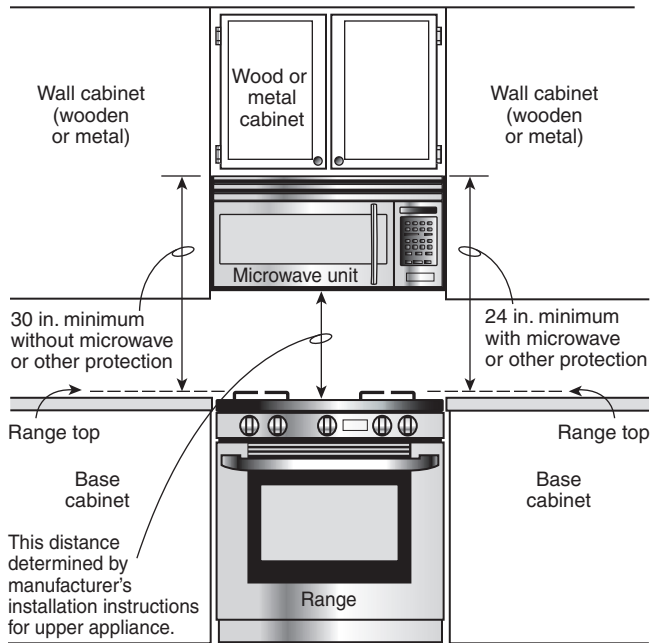

FIGURE A.10.14.1 Separation Requirements for Cooktops.

▲ **A.10.2.6** Reference can be made to NFPA 90A or to NFPA 90B.

A.10.3.6 For details of requirements on low-pressure heating boiler safety devices, refer to ASME *Boiler and Pressure Vessel Code*, Section IV, "Rules for Construction of Heating Boilers."

▲ **A.10.3.7.3** Reference can be made to NFPA 90A or to NFPA 90B.

A.10.6.1 For information on decorative appliances for installation in vented fireplaces, see ANSI Z21.60/CSA 2.26, *Decorative Gas Appliances for Installation in Solid-Fuel Burning Fireplaces*.

A.10.7.1 For information on vented gas fireplaces, see ANSI Z21.50/CSA 2.22, *Vented Gas Fireplaces*.

A.10.9.2.2 Recirculation of room air can be hazardous in the presence of flammable solids, liquids, gases, explosive materials (e.g., grain dust, coal dust, gun powder), and substances (e.g., refrigerants, aerosols) that can become toxic when exposed to flame or heat.

A.10.12.8 Where exhaust fans are used for ventilation, precautions might be necessary to avoid interference with the operation of the appliance.

A.10.14.1 See Figure A.10.14.1

A.10.22.1 It is recommended that space heating appliances installed in all bedrooms or rooms generally kept closed be of the direct vent type.

A.10.27.7 A hole near the top of a cold water inlet tube that enters the top of the water heater or tank is commonly accepted for this purpose.

▲ **A.11.1.1** For most burners, the input rate can be changed only slightly by changing the input pressure. Burner input should be checked in accordance with the appliance manufacturer's installation instructions. If no appliance instructions are provided, burner input rate can be checked as follows:

- (1) *Checking Burner Input Using a Meter (Clocking).* To check the Btu/hr input rate, the test hand on the gas meter should be timed for at least one revolution and the input determined from this timing. Test dials are generally marked $\frac{1}{2}$, 1, 2, or 5 ft³/revolution depending on the size of the meter. Instructions for converting the test hand readings to cubic feet per hour are given in Table A.11.1.1. This table is provided for specific gas pressures within the meters and gives gas flow rate (corrected to standard conditions) in cubic feet of gas per hour. Standard temperature is 60°F (16°C), and standard pressure is 30.00 in. of mercury. Measure the time for at least one revolution of a dial. Look up the gas flow rate in Table

A.11.1.1. Gas flow rates can be calculated for meter pressures other than in these tables in the following manner. A pressure correction factor **F** should be determined for use in the gas input calculation for the gas pressure difference ΔP between the meter inlet and the atmosphere. The gas supplier can provide the pressure at the meter inlet. The pressure correction factor **F** is calculated with the following formula. Table A.11.1.1 was calculated using this formula.

[A.11.1.1(1)a]

$$F = \frac{\Delta P + (B \times 13.596)}{30.00 \times 13.596}$$

where:

- F** = pressure correction factor
- ΔP = meter inlet pressure (in. w.c.)
- B** = barometric pressure, unadjusted to sea level (in. of mercury)

NOAA weather reports barometric pressure in inches of mercury, adjusted to sea level. The sea level adjustment must be subtracted from the barometric pressure reported by NOAA weather. The local sea level adjustment can be obtained from NOAA.

For example, NOAA reported barometric pressure to be 30.12 in. of mercury for a city at 250 ft elevation. The barometric pressure adjustment for 250 ft is 0.27 in. of mercury. Subtract the local sea level adjustment from the NOAA barometric pressure to get the unadjusted barometric pressure.

[A.11.1.1(1)b]

$$30.12 - 0.27 = 29.85$$

The gas flow rate **Q** is calculated using the following formula:

[A.11.1.1(1)c]

$$Q = F \times C$$

where:

- Q** = gas flow rate at standard conditions (ft³/hr)
- F** = pressure correction factor
- C** = timed gas flow rate (ft³/hr)

The gas input rate **I** is calculated with the following formula:

[A.11.1.1(1)d]

$$I = Q \times HHV$$

where:

- I** = gas input rate (Btu/hr)
- Q** = gas flow rate at standard conditions (ft³/hr)
- HHV** = average higher heat value of the gas at standard temperature and pressure conditions (Btu/ft³), which can be obtained from the gas supplier

Appliances can be seriously overfired if the timed meter gas flow rate used to set input rate is not adjusted for meter pressure. At 2 psi (14 kPa) meter pressure, an appliance would be 13 percent overfired if the gas flow rate is not adjusted for meter pressure.

- (2) *Checking Burner Input by Using Orifice Pressure Drop and Orifice Size.* The fixed orifice size for each burner can be determined in accordance with Table E.1.1(a) for utility gases and Table E.1.1(b) for undiluted LP-Gases.

A.11.2 Normally, the primary air adjustment should first be set to give a soft blue flame having luminous tips and then increased to a point where the yellow tips just disappear. If the burner cannot be so adjusted, the manufacturer or serving gas supplier should be contacted.

A.11.6 A procedure for checking draft can be found in Annex G.5.2.

A.12.1 This chapter recognizes that the choice of venting materials and the methods of installation of venting systems are dependent on the operating characteristics of any connected appliances. The operating characteristics of vented appliances can be categorized with respect to whether greater-than-atmospheric or sub-atmospheric pressure exists within the operating vent system and to whether an appliance generates flue or vent gases that can condense in the venting system.

Draft hood-equipped appliances require a vent design that provides a draft to draw vent products into and through the vent system. Vent design tables and the requirements within this code, both for vents and for provision of combustion air, should be used to ensure that vents will provide this draft.

Higher efficiency appliances that generate low-temperature vent gases that can condense require a venting system that can accommodate the condensate produced. Design of these venting systems is accomplished by the appliance manufacturer. Vent system installation requirements for these appliances are contained in the manufacturer's appliance installation instructions.

A.12.3.3 Information on the construction and installation of ventilating hoods can be obtained from NFPA 96.

A.12.4.4 See A.12.3.3.

A.12.6.1.3 For information on the installation of gas vents in existing masonry chimneys, see Section 12.7.

A.12.6.2.1 Chimney clearance requirements are illustrated in Figure A.12.6.2.1.

A.12.6.5.3 Reference can also be made to the chapter on chimney, gas vent, and fireplace systems of the *ASHRAE Handbook — HVAC Systems and Equipment*.

A.12.7.4.1 Additional information on sizing venting systems can be found in the following:

- (1) Tables in Chapter 13
- (2) The appliance manufacturer's instructions
- (3) The vent system manufacturer's sizing instructions
- (4) Drawings, calculations, and specifications provided by the vent system manufacturer
- (5) Drawings, calculations, and specifications provided by a competent person
- (6) The chapter on chimney, gas vent, and fireplace systems of the *ASHRAE Handbook — HVAC Systems and Equipment*

Table A.11.1.1 Gas Flow Rate to Burner in Cubic Feet per Hour at Standard Temperature and Pressure

| Meter Pressure: | 7.0 in. w.c. or 0.25 psi | | | | 11.0 in. w.c. or 0.40 psi | | | | 55.4 in. w.c. or 2 psi | | | |
|-----------------|----------------------------|-------------------------|-------|-------|---------------------------|-------|-------|-------|------------------------|-------|-------|-------|
| | Seconds for One Revolution | Size of Test Meter Dial | | | | | | | | | | |
| | | ½ ft³ | 1 ft³ | 2 ft³ | 5 ft³ | ½ ft³ | 1 ft³ | 2 ft³ | 5 ft³ | ½ ft³ | 1 ft³ | 2 ft³ |
| 10 | 183 | 366 | 732 | 1831 | 185 | 370 | 739 | 1849 | 204 | 409 | 818 | 2044 |
| 11 | 166 | 333 | 666 | 1664 | 168 | 336 | 672 | 1680 | 186 | 372 | 743 | 1859 |
| 12 | 153 | 305 | 610 | 1526 | 154 | 308 | 616 | 1540 | 170 | 341 | 681 | 1704 |
| 13 | 141 | 282 | 563 | 1408 | 142 | 284 | 569 | 1422 | 157 | 315 | 629 | 1573 |
| 14 | 131 | 262 | 523 | 1308 | 132 | 264 | 528 | 1320 | 146 | 292 | 584 | 1460 |
| 15 | 122 | 244 | 488 | 1221 | 123 | 246 | 493 | 1232 | 136 | 273 | 545 | 1363 |
| 16 | 114 | 229 | 458 | 1144 | 116 | 231 | 462 | 1155 | 128 | 256 | 511 | 1278 |
| 17 | 108 | 215 | 431 | 1077 | 109 | 217 | 435 | 1087 | 120 | 241 | 481 | 1203 |
| 18 | 102 | 203 | 407 | 1017 | 103 | 205 | 411 | 1027 | 114 | 227 | 454 | 1136 |
| 19 | 96 | 193 | 385 | 964 | 97 | 195 | 389 | 973 | 108 | 215 | 430 | 1076 |
| 20 | 92 | 183 | 366 | 915 | 92 | 185 | 370 | 924 | 102 | 204 | 409 | 1022 |
| 21 | 87 | 174 | 349 | 872 | 88 | 176 | 352 | 880 | 97 | 195 | 389 | 974 |
| 22 | 83 | 166 | 333 | 832 | 84 | 168 | 336 | 840 | 93 | 186 | 372 | 929 |
| 23 | 80 | 159 | 318 | 796 | 80 | 161 | 321 | 804 | 89 | 178 | 356 | 889 |
| 24 | 76 | 153 | 305 | 763 | 77 | 154 | 308 | 770 | 85 | 170 | 341 | 852 |
| 25 | 73 | 146 | 293 | 732 | 74 | 148 | 296 | 739 | 82 | 164 | 327 | 818 |
| 26 | 70 | 141 | 282 | 704 | 71 | 142 | 284 | 711 | 79 | 157 | 315 | 786 |
| 27 | 68 | 136 | 271 | 678 | 68 | 137 | 274 | 685 | 76 | 151 | 303 | 757 |
| 28 | 65 | 131 | 262 | 654 | 66 | 132 | 264 | 660 | 73 | 146 | 292 | 730 |
| 29 | 63 | 126 | 253 | 631 | 64 | 127 | 255 | 637 | 70 | 141 | 282 | 705 |
| 30 | 61 | 122 | 244 | 610 | 62 | 123 | 246 | 616 | 68 | 136 | 273 | 681 |
| 31 | 59 | 118 | 236 | 591 | 60 | 119 | 239 | 596 | 66 | 132 | 264 | 660 |
| 32 | 57 | 114 | 229 | 572 | 58 | 116 | 231 | 578 | 64 | 128 | 256 | 639 |
| 33 | 55 | 111 | 222 | 555 | 56 | 112 | 224 | 560 | 62 | 124 | 248 | 620 |
| 34 | 54 | 108 | 215 | 538 | 54 | 109 | 217 | 544 | 60 | 120 | 241 | 601 |
| 35 | 52 | 105 | 209 | 523 | 53 | 106 | 211 | 528 | 58 | 117 | 234 | 584 |
| 36 | 51 | 102 | 203 | 509 | 51 | 103 | 205 | 513 | 57 | 114 | 227 | 568 |
| 37 | 49 | 99 | 198 | 495 | 50 | 100 | 200 | 500 | 55 | 111 | 221 | 553 |
| 38 | 48 | 96 | 193 | 482 | 49 | 97 | 195 | 486 | 54 | 108 | 215 | 538 |
| 39 | 47 | 94 | 188 | 469 | 47 | 95 | 190 | 474 | 52 | 105 | 210 | 524 |
| 40 | 46 | 92 | 183 | 458 | 46 | 92 | 185 | 462 | 51 | 102 | 204 | 511 |
| 41 | 45 | 89 | 179 | 447 | 45 | 90 | 180 | 451 | 50 | 100 | 199 | 499 |
| 42 | 44 | 87 | 174 | 436 | 44 | 88 | 176 | 440 | 49 | 97 | 195 | 487 |
| 43 | 43 | 85 | 170 | 426 | 43 | 86 | 172 | 430 | 48 | 95 | 190 | 475 |
| 44 | 42 | 83 | 166 | 416 | 42 | 84 | 168 | 420 | 46 | 93 | 186 | 465 |
| 45 | 41 | 81 | 163 | 407 | 41 | 82 | 164 | 411 | 45 | 91 | 182 | 454 |
| 46 | 40 | 80 | 159 | 398 | 40 | 80 | 161 | 402 | 44 | 89 | 178 | 444 |
| 47 | 39 | 78 | 156 | 390 | 39 | 79 | 157 | 393 | 43 | 87 | 174 | 435 |
| 48 | 38 | 76 | 153 | 381 | 39 | 77 | 154 | 385 | 43 | 85 | 170 | 426 |
| 49 | 37 | 75 | 149 | 374 | 38 | 75 | 151 | 377 | 42 | 83 | 167 | 417 |
| 50 | 37 | 73 | 146 | 366 | 37 | 74 | 148 | 370 | 41 | 82 | 164 | 409 |
| 51 | 36 | 72 | 144 | 359 | 36 | 72 | 145 | 362 | 40 | 80 | 160 | 401 |
| 52 | 35 | 70 | 141 | 352 | 36 | 71 | 142 | 355 | 39 | 79 | 157 | 393 |
| 53 | 35 | 69 | 138 | 345 | 35 | 70 | 140 | 349 | 39 | 77 | 154 | 386 |
| 54 | 34 | 68 | 136 | 339 | 34 | 68 | 137 | 342 | 38 | 76 | 151 | 379 |
| 55 | 33 | 67 | 133 | 333 | 34 | 67 | 134 | 336 | 37 | 74 | 149 | 372 |
| 56 | 33 | 65 | 131 | 327 | 33 | 66 | 132 | 330 | 37 | 73 | 146 | 365 |
| 57 | 32 | 64 | 128 | 321 | 32 | 65 | 130 | 324 | 36 | 72 | 143 | 359 |
| 58 | 32 | 63 | 126 | 316 | 32 | 64 | 127 | 319 | 35 | 70 | 141 | 352 |
| 59 | 31 | 62 | 124 | 310 | 31 | 63 | 125 | 313 | 35 | 69 | 139 | 347 |
| 60 | 31 | 61 | 122 | 305 | 31 | 62 | 123 | 308 | 34 | 68 | 136 | 341 |
| 62 | 30 | 59 | 118 | 295 | 30 | 60 | 119 | 298 | 33 | 66 | 132 | 330 |
| 64 | 29 | 57 | 114 | 286 | 29 | 58 | 116 | 289 | 32 | 64 | 128 | 319 |
| 66 | 28 | 55 | 111 | 277 | 28 | 56 | 112 | 280 | 31 | 62 | 124 | 310 |
| 68 | 27 | 54 | 108 | 269 | 27 | 54 | 109 | 272 | 30 | 60 | 120 | 301 |
| 70 | 26 | 52 | 105 | 262 | 26 | 53 | 106 | 264 | 29 | 58 | 117 | 292 |
| 72 | 25 | 51 | 102 | 254 | 26 | 51 | 103 | 257 | 28 | 57 | 114 | 284 |
| 74 | 25 | 49 | 99 | 247 | 25 | 50 | 100 | 250 | 28 | 55 | 111 | 276 |
| 76 | 24 | 48 | 96 | 241 | 24 | 49 | 97 | 243 | 27 | 54 | 108 | 269 |
| 78 | 23 | 47 | 94 | 235 | 24 | 47 | 95 | 237 | 26 | 52 | 105 | 262 |
| 80 | 23 | 46 | 92 | 229 | 23 | 46 | 92 | 231 | 26 | 51 | 102 | 256 |
| 82 | 22 | 45 | 89 | 223 | 23 | 45 | 90 | 225 | 25 | 50 | 100 | 249 |
| 84 | 22 | 44 | 87 | 218 | 22 | 44 | 88 | 220 | 24 | 49 | 97 | 243 |
| 86 | 21 | 43 | 85 | 213 | 21 | 43 | 86 | 215 | 24 | 48 | 95 | 238 |
| 88 | 21 | 42 | 83 | 208 | 21 | 42 | 84 | 210 | 23 | 46 | 93 | 232 |
| 90 | 20 | 41 | 81 | 203 | 21 | 41 | 82 | 205 | 23 | 45 | 91 | 227 |
| 94 | 19 | 39 | 78 | 195 | 20 | 39 | 79 | 197 | 22 | 43 | 87 | 217 |
| 98 | 19 | 37 | 75 | 187 | 19 | 38 | 75 | 189 | 21 | 42 | 83 | 209 |
| 100 | 18 | 37 | 73 | 183 | 18 | 37 | 74 | 185 | 20 | 41 | 82 | 204 |
| 104 | 18 | 35 | 70 | 176 | 18 | 36 | 71 | 178 | 20 | 39 | 79 | 197 |
| 108 | 17 | 34 | 68 | 170 | 17 | 34 | 68 | 171 | 19 | 38 | 76 | 189 |

(continues)

Table A.11.1.1 *Continued*

| Meter Pressure: | 7.0 in. w.c. or 0.25 psi | | | | 11.0 in. w.c. or 0.40 psi | | | | 55.4 in. w.c. or 2 psi | | | |
|----------------------------|--------------------------|-------|-------|-------|---------------------------|-------|-------|-------|------------------------|-------|-------|-------|
| | Size of Test Meter Dial | | | | | | | | | | | |
| Seconds for One Revolution | ½ ft³ | 1 ft³ | 2 ft³ | 5 ft³ | ½ ft³ | 1 ft³ | 2 ft³ | 5 ft³ | ½ ft³ | 1 ft³ | 2 ft³ | 5 ft³ |
| 112 | 16 | 33 | 65 | 163 | 17 | 33 | 66 | 165 | 18 | 37 | 73 | 183 |
| 116 | 16 | 32 | 63 | 158 | 16 | 32 | 64 | 159 | 18 | 35 | 70 | 176 |
| 120 | 15 | 31 | 61 | 153 | 15 | 31 | 62 | 154 | 17 | 34 | 68 | 170 |
| 130 | 14 | 28 | 56 | 141 | 14 | 28 | 57 | 142 | 16 | 31 | 63 | 157 |
| 140 | 13 | 26 | 52 | 131 | 13 | 26 | 53 | 132 | 15 | 29 | 58 | 146 |
| 150 | 12 | 24 | 49 | 122 | 12 | 25 | 49 | 123 | 14 | 27 | 55 | 136 |
| 160 | 11 | 23 | 46 | 114 | 12 | 23 | 46 | 116 | 13 | 26 | 51 | 128 |
| 170 | 11 | 22 | 43 | 108 | 11 | 22 | 43 | 109 | 12 | 24 | 48 | 120 |
| 180 | 10 | 20 | 41 | 102 | 10 | 21 | 41 | 103 | 11 | 23 | 45 | 114 |
| 190 | 10 | 19 | 39 | 96 | 10 | 19 | 39 | 97 | 11 | 22 | 43 | 108 |
| 200 | 9 | 18 | 37 | 92 | 9 | 18 | 37 | 92 | 10 | 20 | 41 | 102 |

Note: To convert to Btu per hour, multiply the cubic feet per hour of gas by the Btu per cubic foot heating value of the gas used.

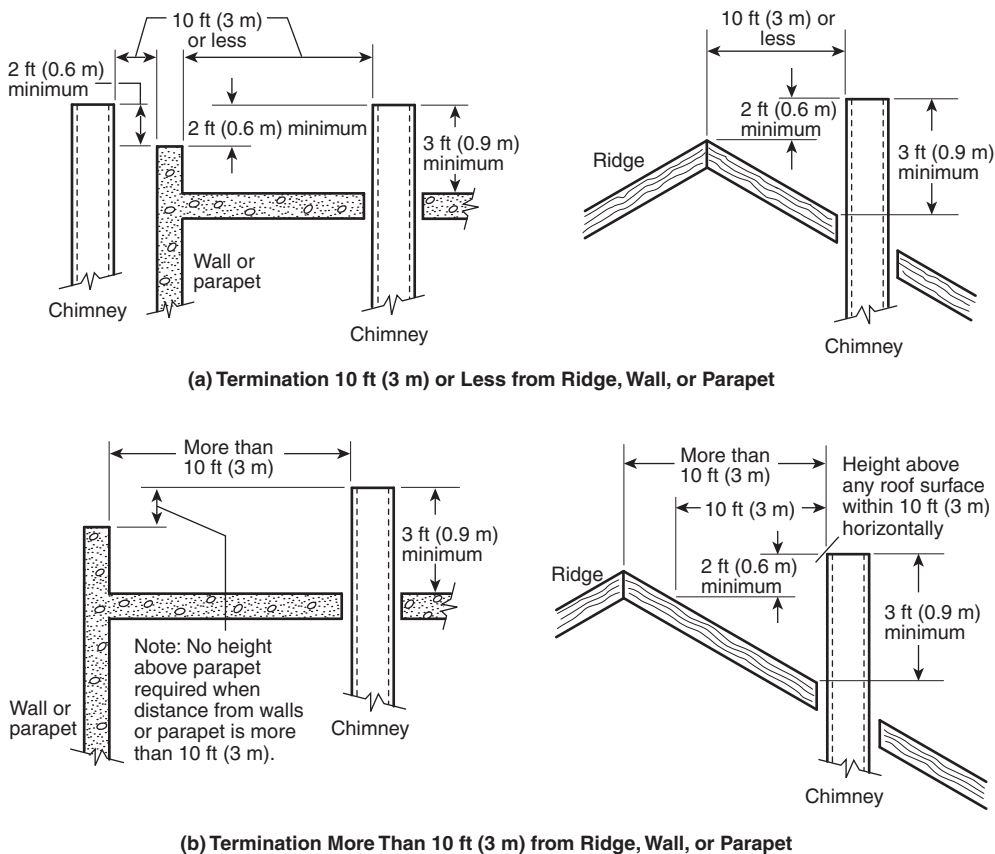

FIGURE A.12.6.2.1 Typical Termination Locations for Chimneys and Single-Wall Metal Pipes Serving Residential-Type and Low-Heat Appliances.

Category I appliances can be either draft hood–equipped or a fan-assisted combustion system in design. Different vent design methods are required for draft hood–equipped and fan-assisted combustion system appliances.

A.12.7.5.2 An example of practical separation of multistory gas venting is provided in Figure A.12.7.5.2.

A.12.8.2 Data on winter design temperature can be found in Figure F.2.4 and the 2009 edition of the *ASHRAE Handbook — Fundamentals*.

A.12.8.4.1 The prohibition only applies to a vent entirely constructed of single-wall metal pipe located in a residential occupancy. The prohibition does not apply to single-wall vent connectors used to connect an appliance to the vent as permitted in Section 12.11 and Chapter 13.

A.12.8.5(1) Reference can also be made to the chapter on chimney, gas vent, and fireplace systems of the *ASHRAE Handbook — HVAC Systems and Equipment*.

A.12.9 See Figure A.12.9.

A.12.11.3 Reference can also be made to the chapter on chimney, gas vent, and fireplace systems of the *ASHRAE Handbook — HVAC Systems and Equipment*.

A.12.11.8 A vent connector should be installed so as to avoid turns or other construction features that create excessive resistance to flow of vent gases. A vent connector should be as short as practical, and the appliance located as close as practical, to the chimney or vent.

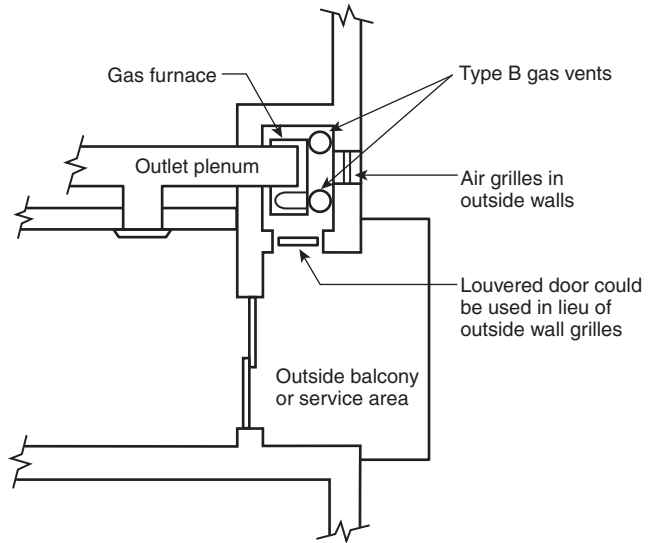

FIGURE A.12.7.5.2 Plan View of Practical Separation Method for Multistory Gas Venting.

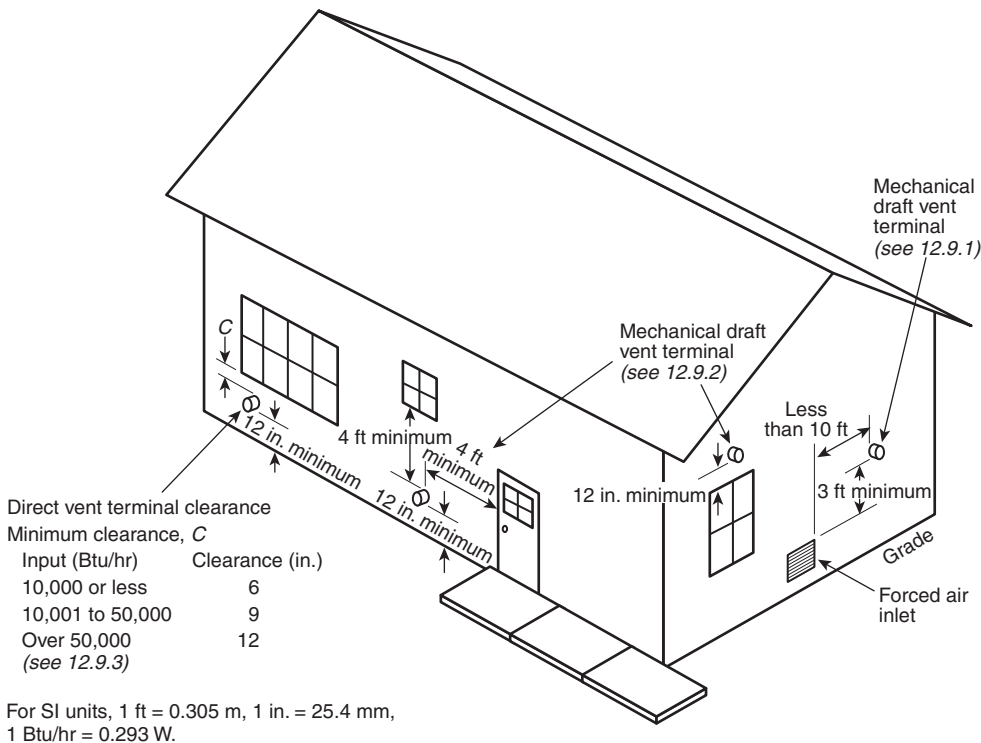

FIGURE A.12.9 Exit Terminals of Mechanical Draft and Direct Vent Venting Systems.

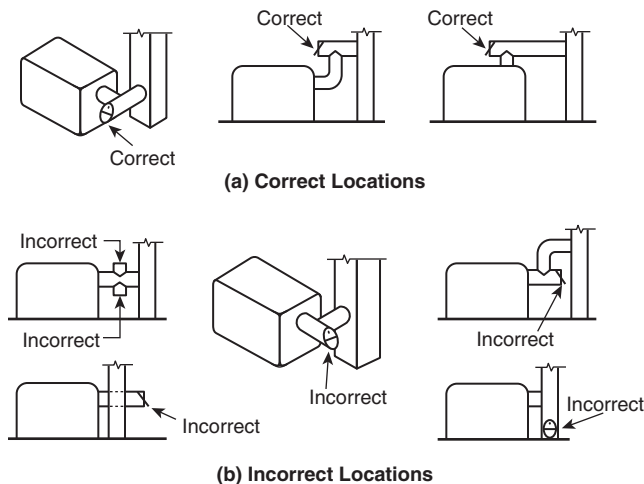

FIGURE A.12.13.4 Locations for Barometric Draft Regulators.

A.12.13.4 A device that automatically shuts off gas to the burner in the event of sustained backdraft is recommended if such backdraft might adversely affect burner operation or if flue gas spillage might introduce a hazard. Figure A.12.13.4 shows examples of correct and incorrect locations for barometric draft regulators.

A.13.1.7 A long radius turn is a turn where the centerline radius is equal to or greater than 1.5 times the vent diameter.

A.13.2.20 A long radius turn is a turn where the centerline radius is equal to or greater than 1.5 times the vent diameter.

Annex B Sizing and Capacities of Gas Piping

This annex is not a part of the requirements of this NFPA document but is included for informational purposes only.

B.1 Sizing Factors. The first goal of determining the pipe sizing of a fuel gas piping system is to be assured that the gas pressure at the inlet to each appliance is sufficient. The majority of systems are residential, and the appliances all have the same, or nearly the same, requirement for minimum gas pressure at the appliance inlet. This pressure is about 5 in. (1.2 kPa) w.c., which is enough for proper operation of the appliance regulator to deliver about 3.5 in. (0.87 kPa) w.c. to the burner itself. The pressure drop in the piping is subtracted from the source delivery pressure to verify that the minimum is available at the appliance.

There are other systems, however, where the required inlet pressure to the different appliances could be quite varied. In such cases, the greatest inlet pressure required must be satisfied, as well as the farthest appliance, which is almost always the critical appliance in small systems.

There is an additional requirement to be observed besides the capacity of the system at 100 percent flow. That require-

ment is that at minimum flow, the pressure at the inlet to any appliance does not exceed the pressure rating of the appliance regulator. This factor would seldom be of concern in small systems if the source pressure is $\frac{1}{2}$ psi (14 in. w.c.) (3.4 kPa) or less, but it should be verified for systems with greater gas pressure at the point of supply.

B.2 General Pipe Sizing Considerations. To determine the size of piping used in a gas piping system, the following factors must be considered:

- (1) Allowable loss in pressure from point of delivery to appliance
- (2) Maximum gas demand
- (3) Length of piping and number of fittings
- (4) Specific gravity of the gas
- (5) Diversity factor

For any gas piping system, or special appliance, or for conditions other than those covered by the tables provided in this code, such as longer runs, greater gas demands, or greater pressure drops, the size of each gas piping system should be determined by standard engineering practices acceptable to the authority having jurisdiction.







B.3 Description of Tables.

B.3.1 General. The quantity of gas to be provided at each outlet should be determined, whenever possible, directly from the manufacturer's gas input Btu/hr rating of the appliance to be installed, adjusted for altitude where appropriate. In case the ratings of the appliances to be installed are not known, Table A.5.4.2.1 shows the approximate consumption (in Btu per hour) of certain types of typical household appliances.

To obtain the cubic feet per hour of gas required, divide the total Btu/hr input of all appliances by the average Btu heating value per cubic foot of the gas. The average Btu per cubic foot of the gas in the area of the installation can be obtained from the serving gas supplier.











B.3.2 Low-Pressure Natural Gas Tables. Capacities for gas at low pressure [2.0 psi (14 kPa gauge) or less] in cubic feet per hour of 0.60 specific gravity gas for different sizes and lengths are shown in Table 6.2.1(a) through Table 6.2.1(d) for iron pipe or equivalent rigid pipe, in Table 6.2.1(h) through Table 6.2.1(k) for smooth wall semirigid tubing, in Table 6.2.1(o) through Table 6.2.1(q) for corrugated stainless steel tubing, and in Table 6.2.1(t) and Table 6.2.1(u) for polyethylene plastic pipe. Table 6.2.1(a) and Table 6.2.1(h) are based on a pressure drop of 0.3 in. w.c. (75 Pa), whereas Table 6.2.1(b), Table 6.2.1(i), and Table 6.2.1(o) are based on a pressure drop of 0.5 in. w.c. (125 Pa). Table 6.2.1(j), Table 6.2.1(p), and Table 6.2.1(q) are special low-pressure applications based on pressure drops greater than 0.5 in. w.c. (125 Pa). In using Table 6.2.1(j), Table 6.2.1(p), or Table 6.2.1(q), an allowance (in equivalent length of pipe) should be considered for any piping run with four or more fittings (see Table B.3.2).

Table B.3.2 Equivalent Lengths of Pipe Fittings and Valves

| | | Screwed Fittings ¹ | | | | 90° Welding Elbows and Smooth Bends ² | | | | | |
|------------------------------------------|-----------------------------------------------------|-----------------------------------------------------------------------------------|-----------------------------------------------------------------------------------|-----------------------------------------------------------------------------------|-----------------------------------------------------------------------------------|-----------------------------------------------------------------------------------|-----------------------------------------------------------------------------------|---------|---------|---------|---------|
| | | 45°/El | 90°/El | 180° Close Return Bends | Tee | R/d = 1 | R/d = 1 1/3 | R/d = 2 | R/d = 4 | R/d = 6 | R/d = 8 |
| | | <i>k</i> factor = | 0.42 | 0.90 | 2.00 | 1.80 | 0.48 | 0.36 | 0.27 | 0.21 | 0.27 |
| <i>L/d</i> ratio ⁴ <i>n</i> = | | 14 | 30 | 67 | 60 | 16 | 12 | 9 | 7 | 9 | 12 |
| Nominal Pipe Size (in.) | Inside Diam. <i>d</i> (in.), Sched. 40 ⁶ |  |  |  |  |  |  | | | | |

L = Equivalent Length in Feet of Schedule 40 (Standard Weight) Straight Pipe⁶

| | | | | | | | | | | | |
|-------|-------|------|------|------|------|------|------|------|------|------|------|
| 1/2 | 0.622 | 0.73 | 1.55 | 3.47 | 3.10 | 0.83 | 0.62 | 0.47 | 0.36 | 0.47 | 0.62 |
| 3/4 | 0.824 | 0.96 | 2.06 | 4.60 | 4.12 | 1.10 | 0.82 | 0.62 | 0.48 | 0.62 | 0.82 |
| 1 | 1.049 | 1.22 | 2.62 | 5.82 | 5.24 | 1.40 | 1.05 | 0.79 | 0.61 | 0.79 | 1.05 |
| 1 1/4 | 1.380 | 1.61 | 3.45 | 7.66 | 6.90 | 1.84 | 1.38 | 1.03 | 0.81 | 1.03 | 1.38 |
| 1 1/2 | 1.610 | 1.88 | 4.02 | 8.95 | 8.04 | 2.14 | 1.61 | 1.21 | 0.94 | 1.21 | 1.61 |
| 2 | 2.067 | 2.41 | 5.17 | 11.5 | 10.3 | 2.76 | 2.07 | 1.55 | 1.21 | 1.55 | 2.07 |
| 2 1/2 | 2.469 | 2.88 | 6.16 | 13.7 | 12.3 | 3.29 | 2.47 | 1.85 | 1.44 | 1.85 | 2.47 |
| 3 | 3.068 | 3.58 | 7.67 | 17.1 | 15.3 | 4.09 | 3.07 | 2.30 | 1.79 | 2.30 | 3.07 |
| 4 | 4.026 | 4.70 | 10.1 | 22.4 | 20.2 | 5.37 | 4.03 | 3.02 | 2.35 | 3.02 | 4.03 |
| 5 | 5.047 | 5.88 | 12.6 | 28.0 | 25.2 | 6.72 | 5.05 | 3.78 | 2.94 | 3.78 | 5.05 |
| 6 | 6.065 | 7.07 | 15.2 | 33.8 | 30.4 | 8.09 | 6.07 | 4.55 | 3.54 | 4.55 | 6.07 |
| 8 | 7.981 | 9.31 | 20.0 | 44.6 | 40.0 | 10.6 | 7.98 | 5.98 | 4.65 | 5.98 | 7.98 |
| 10 | 10.02 | 11.7 | 25.0 | 55.7 | 50.0 | 13.3 | 10.0 | 7.51 | 5.85 | 7.51 | 10.0 |
| 12 | 11.94 | 13.9 | 29.8 | 66.3 | 59.6 | 15.9 | 11.9 | 8.95 | 6.96 | 8.95 | 11.9 |
| 14 | 13.13 | 15.3 | 32.8 | 73.0 | 65.6 | 17.5 | 13.1 | 9.85 | 7.65 | 9.85 | 13.1 |
| 16 | 15.00 | 17.5 | 37.5 | 83.5 | 75.0 | 20.0 | 15.0 | 11.2 | 8.75 | 11.2 | 15.0 |
| 18 | 16.88 | 19.7 | 42.1 | 93.8 | 84.2 | 22.5 | 16.9 | 12.7 | 9.85 | 12.7 | 16.9 |
| 20 | 18.81 | 22.0 | 47.0 | 105 | 94.0 | 25.1 | 18.8 | 14.1 | 11.0 | 14.1 | 18.8 |
| 24 | 22.63 | 26.4 | 56.6 | 126 | 113 | 30.2 | 22.6 | 17.0 | 13.2 | 17.0 | 22.6 |











| Miter Elbows ³ (No. of Miters) | | | | | Welding Tees | | Valves (Screwed, Flanged, or Welded) | | | |
|-------------------------------------------------------------------------------------|-------------------------------------------------------------------------------------|-------------------------------------------------------------------------------------|-------------------------------------------------------------------------------------|-------------------------------------------------------------------------------------|-------------------------------------------------------------------------------------|-------------------------------------------------------------------------------------|---------------------------------------------------------------------------------------|---------------------------------------------------------------------------------------|---------------------------------------------------------------------------------------|---------------------------------------------------------------------------------------|
| 1-45° | 1-60° | 1-90° | 2-90° | 3-90° | Forged | Miter ³ | Gate | Globe | Angle | Swing Check |
| 0.45 | 0.90 | 1.80 | 0.60 | 0.45 | 1.35 | 1.80 | 0.21 | 10 | 5.0 | 2.5 |
| 15 | 30 | 60 | 20 | 15 | 45 | 60 | 7 | 333 | 167 | 83 |
|  |  |  |  |  |  |  |  |  |  |  |

L = Equivalent Length in Feet of Schedule 40 (Standard Weight) Straight Pipe⁶

| | | | | | | | | | | |
|------|------|------|------|------|------|------|------|------|------|------|
| 0.78 | 1.55 | 3.10 | 1.04 | 0.78 | 2.33 | 3.10 | 0.36 | 17.3 | 8.65 | 4.32 |
| 1.03 | 2.06 | 4.12 | 1.37 | 1.03 | 3.09 | 4.12 | 0.48 | 22.9 | 11.4 | 5.72 |
| 1.31 | 2.62 | 5.24 | 1.75 | 1.31 | 3.93 | 5.24 | 0.61 | 29.1 | 14.6 | 7.27 |
| 1.72 | 3.45 | 6.90 | 2.30 | 1.72 | 5.17 | 6.90 | 0.81 | 38.3 | 19.1 | 9.58 |
| 2.01 | 4.02 | 8.04 | 2.68 | 2.01 | 6.04 | 8.04 | 0.94 | 44.7 | 22.4 | 11.2 |
| 2.58 | 5.17 | 10.3 | 3.45 | 2.58 | 7.75 | 10.3 | 1.21 | 57.4 | 28.7 | 14.4 |
| 3.08 | 6.16 | 12.3 | 4.11 | 3.08 | 9.25 | 12.3 | 1.44 | 68.5 | 34.3 | 17.1 |
| 3.84 | 7.67 | 15.3 | 5.11 | 3.84 | 11.5 | 15.3 | 1.79 | 85.2 | 42.6 | 21.3 |
| 5.04 | 10.1 | 20.2 | 6.71 | 5.04 | 15.1 | 20.2 | 2.35 | 112 | 56.0 | 28.0 |
| 6.30 | 12.6 | 25.2 | 8.40 | 6.30 | 18.9 | 25.2 | 2.94 | 140 | 70.0 | 35.0 |

(continues)

Table B.3.2 Continued

| Miter Elbows ³ (No. of Miters) | | | | | Welding Tees | | Valves (Screwed, Flanged, or Welded) | | | |
|-------------------------------------------------------------------------------------------------|-----------------------------------------------------------------------------------|-----------------------------------------------------------------------------------|-----------------------------------------------------------------------------------|-----------------------------------------------------------------------------------|-----------------------------------------------------------------------------------|------------------------------------------------------------------------------------|-------------------------------------------------------------------------------------|-------------------------------------------------------------------------------------|-------------------------------------------------------------------------------------|-------------------------------------------------------------------------------------|
| 1-45° | 1-60° | 1-90° | 2-90° | 3-90° | Forged | Miter ³ | Gate | Globe | Angle | Swing Check |
| 0.45 | 0.90 | 1.80 | 0.60 | 0.45 | 1.35 | 1.80 | 0.21 | 10 | 5.0 | 2.5 |
| 15 | 30 | 60 | 20 | 15 | 45 | 60 | 7 | 333 | 167 | 83 |
|  |  |  |  |  |  |  |  |  |  |  |
| L = Equivalent Length in Feet of Schedule 40 (Standard Weight) Straight Pipe⁶ | | | | | | | | | | |
| 7.58 | 15.2 | 30.4 | 10.1 | 7.58 | 22.8 | 30.4 | 3.54 | 168 | 84.1 | 42.1 |
| 9.97 | 20.0 | 40.0 | 13.3 | 9.97 | 29.9 | 40.0 | 4.65 | 222 | 111 | 55.5 |
| 12.5 | 25.0 | 50.0 | 16.7 | 12.5 | 37.6 | 50.0 | 5.85 | 278 | 139 | 69.5 |
| 14.9 | 29.8 | 59.6 | 19.9 | 14.9 | 44.8 | 59.6 | 6.96 | 332 | 166 | 83.0 |
| 16.4 | 32.8 | 65.6 | 21.9 | 16.4 | 49.2 | 65.6 | 7.65 | 364 | 182 | 91.0 |
| 18.8 | 37.5 | 75.0 | 25.0 | 18.8 | 56.2 | 75.0 | 8.75 | 417 | 208 | 104 |
| 21.1 | 42.1 | 84.2 | 28.1 | 21.1 | 63.2 | 84.2 | 9.85 | 469 | 234 | 117 |
| 23.5 | 47.0 | 94.0 | 31.4 | 23.5 | 70.6 | 94.0 | 11.0 | 522 | 261 | 131 |
| 28.3 | 56.6 | 113 | 37.8 | 28.3 | 85.0 | 113 | 13.2 | 629 | 314 | 157 |

For SI units, 1 ft = 0.305 m.

Note: Values for welded fittings are for conditions where bore is not obstructed by weld spatter or backing rings. If appreciably obstructed, use values for "Screwed Fittings."

¹Flanged fittings have three-fourths the resistance of screwed elbows and tees.

²Tabular figures give the extra resistance due to curvature alone to which should be added the full length of travel.

³Small size socket-welding fittings are equivalent to miter elbows and miter tees.

⁴Equivalent resistance in number of diameters of straight pipe computed for a value of $f = 0.0075$ from the relation $n = k/4f$.

⁵For condition of minimum resistance where the centerline length of each miter is between d and $2\frac{1}{2}d$.

⁶For pipe having other inside diameters, the equivalent resistance may be computed from the above n values.

Source: From *Piping Handbook*, Table XIV, pp. 100–101. Used by permission of McGraw-Hill Book Company.

B.3.3 Undiluted LP-Gas Tables. Capacities in thousands of Btu per hour of undiluted LP-Gases based on a pressure drop of 0.5 in. w.c. (125 Pa) for different sizes and lengths are shown in Table 6.3.1(d) for iron pipe or equivalent rigid pipe, in Table 6.3.1(f) for smooth wall semirigid tubing, in Table 6.3.1(h) for corrugated stainless steel tubing, and in Table 6.3.1(k) and Table 6.3.1(m) for polyethylene plastic pipe and tubing. Table 6.3.1(i) and Table 6.3.1(j) for corrugated stainless steel tubing and Table 6.3.1(l) for polyethylene plastic pipe are based on operating pressures greater than 0.5 psi (3.5 kPa) and pressure drops greater than 0.5 in. w.c. (125 Pa). In using these tables, an allowance (in equivalent length of pipe) should be considered for any piping run with four or more fittings (see Table B.3.2).

B.3.4 Natural Gas Specific Gravity. Gas piping systems that are to be supplied with gas of a specific gravity of 0.70 or less can be sized directly from the tables provided in this code, unless the authority having jurisdiction specifies that a gravity factor be applied. Where the specific gravity of the gas is greater than 0.70, the gravity factor should be applied.

Application of the gravity factor converts the figures given in the tables provided in this code to capacities for another gas of different specific gravity. Such application is accomplished by multiplying the capacities given in the tables by the multipliers shown in Table B.3.4. In case the exact specific gravity does not appear in the table, choose the next higher value specific gravity shown.

B.3.5 Higher Pressure Natural Gas Tables. Capacities for gas at pressures of 2 psi (14 kPa) and greater in cubic feet per hour of 0.60 specific gravity gas for different sizes and lengths are shown in Table 6.2.1(e) and Table 6.2.1(f) for iron pipe or equivalent rigid pipe, Table 6.2.1(l) through Table 6.2.1(n) for semirigid tubing, Table 6.2.1(r) and Table 6.2.1(s) for corruga-

Table B.3.4 SPECIAL USE: Multipliers to Be Used with Tables 6.2.1 (a) Through 6.2.1(x) When the Specific Gravity of the Gas Is Other than 0.60

| Specific Gravity | Multiplier | Specific Gravity | Multiplier |
|------------------|------------|------------------|------------|
| 0.35 | 1.31 | 1.00 | 0.78 |
| 0.40 | 1.23 | 1.10 | 0.74 |
| 0.45 | 1.16 | 1.20 | 0.71 |
| 0.50 | 1.10 | 1.30 | 0.68 |
| 0.55 | 1.04 | 1.40 | 0.66 |
| 0.60 | 1.00 | 1.50 | 0.63 |
| 0.65 | 0.96 | 1.60 | 0.61 |
| 0.70 | 0.93 | 1.70 | 0.59 |
| 0.75 | 0.90 | 1.80 | 0.58 |
| 0.80 | 0.87 | 1.90 | 0.56 |
| 0.85 | 0.84 | 2.00 | 0.55 |
| 0.90 | 0.82 | 2.10 | 0.54 |

ted stainless steel tubing, and Table 6.2.1(u) and Table 6.2.1(v) for polyethylene plastic pipe.

B.4 Use of Capacity Tables.

B.4.1 The Longest Length Method. This sizing method is conservative in its approach by applying the maximum operating conditions in the system as the norm for the system and by setting the length of pipe used to size any given part of the piping system to the maximum value.

To determine the size of each section of gas piping in a system within the range of the capacity tables, proceed as follows (*also see sample calculations included in this annex*):

- (1) Divide the piping system into appropriate segments consistent with the presence of tees, branch lines, and main runs. For each segment, determine the gas load (assuming all appliances operate simultaneously) and its overall length. An allowance (in equivalent length of pipe) as determined from Table B.3.2 should be considered for piping segments that include four or more fittings.
- (2) Determine the gas demand of each appliance to be attached to the piping system. Where Table 6.2.1(a) through Table 6.2.1(x) are to be used to select the piping size, calculate the gas demand in terms of cubic feet per hour for each piping system outlet. Where Table 6.3.1(a) through Table 6.3.1(m) are to be used to select the piping size, calculate the gas demand in terms of thousands of Btu per hour for each piping system outlet.
- (3) Where the piping system is for use with other than undiluted LP-Gases, determine the design system pressure, the allowable loss in pressure (pressure drop), and specific gravity of the gas to be used in the piping system.
- (4) Determine the length of piping from the point of delivery to the most remote outlet in the building/piping system.
- (5) In the appropriate capacity table, select the row showing the measured length or the next longer length if the table does not give the exact length. This length is the only length used in determining the size of any section of gas piping. If the gravity factor is to be applied, the values in the selected row of the table are multiplied by the appropriate multiplier from Table B.3.4.
- (6) Use this horizontal row to locate ALL gas demand figures for this particular system of piping.
- (7) Starting at the most remote outlet, find the gas demand for that outlet in the horizontal row just selected. If the exact figure of demand is not shown, choose the next larger figure left in the row.
- (8) Opposite this demand figure, in the first row at the top, the correct size of gas piping will be found.
- (9) Proceed in a similar manner for each outlet and each section of gas piping. For each section of piping, determine the total gas demand supplied by that section.

When a large number of piping components (such as elbows, tees, and valves) are installed in a pipe run, additional pressure loss can be accounted for by the use of equivalent lengths. Pressure loss across any piping component can be equated to the pressure drop through a length of pipe. The equivalent length of a combination of only four elbows/tees can result in a jump to the next larger length row, resulting in a significant reduction in capacity. The equivalent lengths in feet shown in Table B.3.2 have been computed on a basis that the inside diameter corresponds to that of Schedule 40 (standard weight) steel pipe, which is close enough for most purposes

involving other schedules of pipe. Where a more specific solution for equivalent length is desired, this can be made by multiplying the actual inside diameter of the pipe in inches by $n/12$, or the actual inside diameter in feet by n . N can be read from the table heading. The equivalent length values can be used with reasonable accuracy for copper or copper alloy fittings and bends, although the resistance per foot of copper or copper alloy pipe is less than that of steel. For copper or copper alloy valves, however, the equivalent length of pipe should be taken as 45 percent longer than the values in the table, which are for steel pipe.

B.4.2 The Branch Length Method. This sizing method reduces the amount of conservatism built into the traditional Longest Length Method. The longest length as measured from the meter to the farthest remote appliance is used only to size the initial parts of the overall piping system. The Branch Length Method is applied in the following manner:

- (1) Determine the gas load for each of the connected appliances.
- (2) Starting from the meter, divide the piping system into a number of connected segments, and determine the length and amount of gas that each segment would carry, assuming that all appliances were operated simultaneously. An allowance (in equivalent length of pipe) as determined from Table B.3.2 should be considered for piping segments that include four or more fittings.
- (3) Determine the distance from the outlet of the gas meter to the appliance farthest removed from the meter.
- (4) Using the longest distance (found in Step 3), size each piping segment from the meter to the most remote appliance outlet.
- (5) For each of these piping segments, use the longest length and the calculated gas load for all of the connected appliances for the segment and begin the sizing process in Steps 6 through 8.
- (6) Referring to the appropriate sizing table (based on operating conditions and piping material), find the longest length distance in the first column or the next larger distance if the exact distance is not listed. The use of alternative operating pressures and/or pressure drops requires the use of a different sizing table but does not alter the sizing methodology. In many cases, the use of alternative operating pressures and/or pressure drops requires the approval of both the authority having jurisdiction and the local gas serving utility.
- (7) Trace across this row until the gas load is found or the closest larger capacity if the exact capacity is not listed.
- (8) Read up the table column and select the appropriate pipe size in the top row. Repeat Steps 6, 7, and 8 for each pipe segment in the longest run.
- (9) Size each remaining section of branch piping not previously sized by measuring the distance from the gas meter location to the most remote outlet in that branch, using the gas load of attached appliances, and follow the procedures of Steps 2 through 8.

B.4.3 Hybrid Pressure Method. The sizing of a 2 psi (14 kPa) gas piping system is performed using the traditional Longest Length Method but with modifications. The 2 psi (14 kPa) system consists of two independent pressure zones, and each zone is sized separately. The Hybrid Pressure Method is applied using the following steps.

The 2 psi (14 kPa) section (from the meter to the line regulator) is sized as follows:

- (1) Calculate the gas load (by adding up the nameplate ratings) from all connected appliances. (In certain circumstances the installed gas load can be increased up to 50 percent to accommodate future addition of appliances.) Ensure that the line regulator capacity is adequate for the calculated gas load and that the required pressure drop (across the regulator) for that capacity does not exceed $\frac{3}{4}$ psi (5.2 kPa) for a 2 psi (14 kPa) system. If the pressure drop across the regulator is too high (for the connected gas load), select a larger regulator.
- (2) Measure the distance from the meter to the line regulator located inside the building.
- (3) If multiple line regulators are used, measure the distance from the meter to the regulator farthest removed from the meter.
- (4) The maximum allowable pressure drop for the 2 psi (14 kPa) section is 1 psi (7 kPa).
- (5) Referring to the appropriate sizing table (based on piping material) for 2 psi (14 kPa) systems with a 1 psi (7 kPa) pressure drop, find this distance in the first column, or the closest larger distance if the exact distance is not listed.
- (6) Trace across this row until the gas load is found or the closest larger capacity if the exact capacity is not listed.
- (7) Read up the table column to the top row and select the appropriate pipe size.
- (8) If multiple regulators are used in this portion of the piping system, each line segment must be sized for its actual gas load, using the longest length previously determined.

The low-pressure section (all piping downstream of the line regulator) is sized as follows:

- (1) Determine the gas load for each of the connected appliances.
- (2) Starting from the line regulator, divide the piping system into a number of connected segments and/or independent parallel piping segments and determine the amount of gas that each segment would carry, assuming that all appliances were operated simultaneously. An allowance (in equivalent length of pipe) as determined from Table B.3.2 should be considered for piping segments that include four or more fittings.
- (3) For each piping segment, use the actual length or longest length (if there are sub-branch lines) and the calculated gas load for that segment and begin the sizing process as follows:
 - (a) Referring to the appropriate sizing table (based on operating pressure and piping material), find the longest length distance in the first column or the closest larger distance if the exact distance is not listed. The use of alternative operating pressures and/or pressure drops requires the use of a different sizing table but does not alter the sizing methodology. In many cases, the use of alternative operating pressures and/or pressure drops could require the approval of the authority having jurisdiction.
 - (b) Trace across this row until the appliance gas load is found or the closest larger capacity if the exact capacity is not listed.

- (c) Read up the table column to the top row and select the appropriate pipe size.
- (d) Repeat this process for each segment of the piping system.

B.4.4 Pressure Drop per 100 ft Method. This sizing method is less conservative than the others, but it allows the designer to immediately see where the largest pressure drop occurs in the system. With this information, modifications can be made to bring the total drop to the critical appliance within the limitations that are presented to the designer.

Follow the procedures described in the Longest Length Method for steps (1) through (4) and step (9).

For each piping segment, calculate the pressure drop based on pipe size, length as a percentage of 100 ft, and gas flow. Table B.4.4 shows pressure drop per 100 ft for pipe sizes from $\frac{1}{2}$ in. through 2 in. The sum of pressure drops to the critical appliance is subtracted from the supply pressure to verify that sufficient pressure is available. If not, the layout can be examined to find the high drop section(s), and sizing selections modified.

B.5 Use of Sizing Equations. Capacities of smooth wall pipe or tubing can also be determined by using the following formulas:

- (1) *High Pressure* [1.5 psi (10.3 kPa) and above]:

[B.5(1)]

$$Q = 181.6 \sqrt{\frac{D^5 \cdot (P_1^2 - P_2^2) \cdot Y}{Cr \cdot fba \cdot L}}$$

$$= 2237 D^{2.623} \left[\frac{(P_1^2 - P_2^2) \cdot Y}{Cr \cdot L} \right]^{0.541}$$

- (2) *Low Pressure* [less than 1.5 psi (10.3 kPa)]:

[B.5(2)]

$$Q = 187.3 \sqrt{\frac{D^5 \cdot \Delta H}{Cr \cdot fba \cdot L}}$$

$$= 2313 D^{2.623} \left(\frac{\Delta H}{Cr \cdot L} \right)^{0.541}$$

where:

Q = rate (cubic feet per hour at 60°F and 30 in. mercury column)

D = inside diameter of pipe (in.)

P_1 = upstream pressure (psia)

P_2 = downstream pressure (psia)

Y = superexpansibility factor = 1/supercompressibility factor

Cr = factor for viscosity, density, and temperature

fba = base friction factor for air at 60°F (CF = 1)

L = length of pipe (ft)

H = pressure drop [in. w.c. (27.7 in. H₂O = 1 psi) = 0.00354 ST/(Z/S)^{0.152}]

See Table 6.4.2 for values of Cr and Y for natural gas and propane.

Table B.4.4 Thousands of Btu/hr of Natural Gas per 100 ft of Pipe at Various Pressure Drops and Pipe Diameters

| Press. Drop/100 ft (in. w.c.) | Pipe Sizes (in.) | | | | | |
|-------------------------------|------------------|-----|-----|-----|-----|------|
| | ½ | ¾ | 1 | 1¼ | 1½ | 2 |
| 0.2 | 31 | 64 | 121 | 248 | 372 | 716 |
| 0.3 | 38 | 79 | 148 | 304 | 455 | 877 |
| 0.5 | 50 | 104 | 195 | 400 | 600 | 1160 |
| 1.0 | 71 | 147 | 276 | 566 | 848 | 1640 |

Note: Other values can be obtained using the following equation:

[B.4.4a]

$$\text{Desired Value} = \text{thousands of Btu/hr} \times \sqrt{\frac{\text{Desired Drop}}{\text{Table Drop}}}$$

For example, if it is desired to get flow through ¾ in. pipe at 2 in. w.c./100 ft, multiply the capacity of ¾ in. pipe at 1 in./100 ft by the square root of the pressure ratio:

[B.4.4b]

$$147,000 \text{ Btu/hr} \times \sqrt{\frac{2 \text{ in. w.c.}}{1 \text{ in. w.c.}}} = 147,000 \times 1.414 = 208,000 \text{ Btu/hr}$$

Δ B.6 Pipe and Tube Diameters. Where the internal diameter is determined by the formulas in Section 6.4, Table B.6(a) and Table B.6(b) can be used to select the nominal or standard pipe size based on the calculated internal diameter.

Δ Table B.6(b) Copper Tube Standard Sizes

Δ Table B.6(a) Schedule 40 Steel Pipe Standard Sizes

| Nominal Size (in.) | Internal Diameter (in.) | Nominal Size (in.) | Internal Diameter (in.) |
|--------------------|-------------------------|--------------------|-------------------------|
| ¼ | 0.364 | 1½ | 1.610 |
| ⅜ | 0.493 | 2 | 2.067 |
| ½ | 0.622 | 2½ | 2.469 |
| ¾ | 0.824 | 3 | 3.068 |
| 1 | 1.049 | 3½ | 3.548 |
| 1¼ | 1.380 | 4 | 4.026 |

| Tube Type | Nominal or Standard Size (in.) | Internal Diameter (in.) | Tube Type | Nominal or Standard Size (in.) | Internal Diameter (in.) |
|------------|--------------------------------|-------------------------|------------|--------------------------------|-------------------------|
| K | ¼ | 0.305 | K | 1 | 0.995 |
| L | ¼ | 0.315 | L | 1 | 1.025 |
| ACR (D) | ⅜ | 0.315 | ACR (D, A) | 1⅜ | 1.025 |
| ACR (A) | ⅝ | 0.311 | K | 1¼ | 1.245 |
| K | ⅝ | 0.402 | L | 1¼ | 1.265 |
| L | ⅝ | 0.430 | ACR (D, A) | 1⅝ | 1.265 |
| ACR (D) | ½ | 0.430 | K | 1½ | 1.481 |
| ACR (A) | ½ | 0.436 | L | 1½ | 1.505 |
| K | ½ | 0.527 | ACR (D, A) | 1⅝ | 1.505 |
| L | ½ | 0.545 | K | 2 | 1.959 |
| ACR (D) | ⅝ | 0.545 | L | 2 | 1.985 |
| ACR (A) | ⅝ | 0.555 | ACR (D, A) | 2⅝ | 1.985 |
| K | ⅝ | 0.652 | K | 2½ | 2.435 |
| L | ⅝ | 0.666 | L | 2½ | 2.465 |
| ACR (D) | ¾ | 0.666 | ACR (D, A) | 2⅝ | 2.465 |
| ACR (A) | ¾ | 0.680 | K | 3 | 2.907 |
| K | ¾ | 0.745 | L | 3 | 2.945 |
| L | ¾ | 0.785 | ACR (D, A) | 3⅝ | 2.945 |
| ACR (D, A) | ⅞ | 0.785 | | | |

B.7 Examples of Piping System Design and Sizing.

Δ B.7.1 Example 1 — Longest Length Method. Determine the required pipe size of each section and outlet of the piping system shown in Figure B.7.1, with a designated pressure drop of 0.50 in. w.c. (125 Pa), using the Longest Length Method. The gas to be used has 0.60 specific gravity and a heating value of 1000 Btu/ft³ (37.5 MJ/m³).

Solution

- (1) Maximum gas demand for outlet A:

$$\frac{\text{Consumption (rating plate input, or Table 5.4.2.1 if necessary)}}{\text{Btu of gas}} \quad [\text{B.7(1)a}]$$

$$= \frac{35,000 \text{ Btu/hr rating}}{1000 \text{ Btu/ft}^3} = 35 \text{ ft}^3/\text{hr} = 35 \text{ cfh}$$

Maximum gas demand for outlet B:

$$\frac{\text{Consumption}}{\text{Btu of gas}} = \frac{75,000}{1000} = 75 \text{ cfh} \quad [\text{B.7(1)b}]$$

Maximum gas demand for outlet C:

$$\frac{\text{Consumption}}{\text{Btu of gas}} = \frac{35,000}{1000} = 35 \text{ cfh} \quad [\text{B.7(1)c}]$$

Maximum gas demand for outlet D:

$$\frac{\text{Consumption}}{\text{Btu of gas}} = \frac{100,000}{1000} = 100 \text{ cfh} \quad [\text{B.7(1)d}]$$

- (2) The length of pipe from the point of delivery to the most remote outlet (A) is 60 ft (18.3 m). This is the only distance used.
- (3) Using the row marked 60 ft (18.3 m) in Table 6.2.1(b):
- Outlet A, supplying 35 cfh (0.99 m³/hr), requires ½ in. pipe.
 - Outlet B, supplying 75 cfh (2.12 m³/hr), requires ¾ in. pipe.
 - Section 1, supplying outlets A and B, or 110 cfh (3.11 m³/hr), requires ¾ in. pipe.
 - Section 2, supplying outlets C and D, or 135 cfh (3.82 m³/hr), requires ¾ in. pipe.
 - Section 3, supplying outlets A, B, C, and D, or 245 cfh (6.94 m³/hr), requires 1 in. pipe.
- (4) If a different gravity factor is applied to this example, the values in the row marked 60 ft (18.3 m) of Table 6.2.1(b) would be multiplied by the appropriate multiplier from Table B.3.4, and the resulting cubic feet per hour values would be used to size the piping.

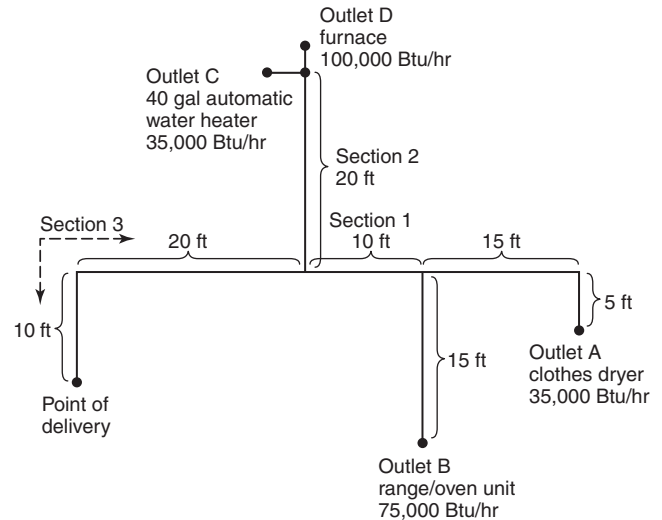

For SI units, 1 ft = 0.305 m, 1 gal = 3.785 L, 1000 Btu/hr = 0.293 kW.

FIGURE B.7.1 Piping Plan Showing a Steel Piping System.

B.7.2 Example 2 — Hybrid or Dual Pressure Systems. Determine the required CSST size of each section of the piping system shown in Figure B.7.2, with a designated pressure drop of 1 psi (7 kPa) for the 2 psi (14 kPa) section and 3 in. w.c. (0.75 kPa) pressure drop for the 10 in. w.c. (2.49 kPa) section. The gas to be used has 0.60 specific gravity and a heating value of 1000 Btu/ft³ (37.5 MJ/m³).

Solution

- Size 2 psi (14 kPa) line using Table 6.2.1(r).
- Size 10 in. w.c. (2.5 kPa) lines using Table 6.2.1(p).
- Using the following steps, determine if sizing tables can be used:
 - Total gas load shown in Figure B.7.2 equals 110 chf (3.11 m³/hr).
 - Determine pressure drop across regulator [see notes in Table 6.2.1(r)].
 - If pressure drop across regulator exceeds ¾ psi (5.2 kPa), Table 6.2.1(r) cannot be used. Note that if pressure drop exceeds ¾ psi (5.2 kPa), a larger regulator must be selected or an alternative sizing method must be used.
 - Pressure drop across the line regulator [for 110 chf/(3.11 m³/hr)] is 4 in. w.c. (0.99 kPa) based on manufacturer's performance data.
 - Assume the CSST manufacturer has tubing sizes or EHDs of 13, 18, 23, and 30.
- From Section A [2 psi (14 kPa) zone]:
 - Determine distance from meter to regulator = 100 ft (30.48 m).
 - Determine total load supplied by A = 110 chf (3.11 m³/hr) (furnace + water heater + dryer).
 - Table 6.2.1(r) shows that EHD size 18 should be used. Note that it is not unusual to oversize the supply line by 25 to 50 percent of the as-installed load. EHD size 18 has a capacity of 189 chf (5.35 m³/hr).

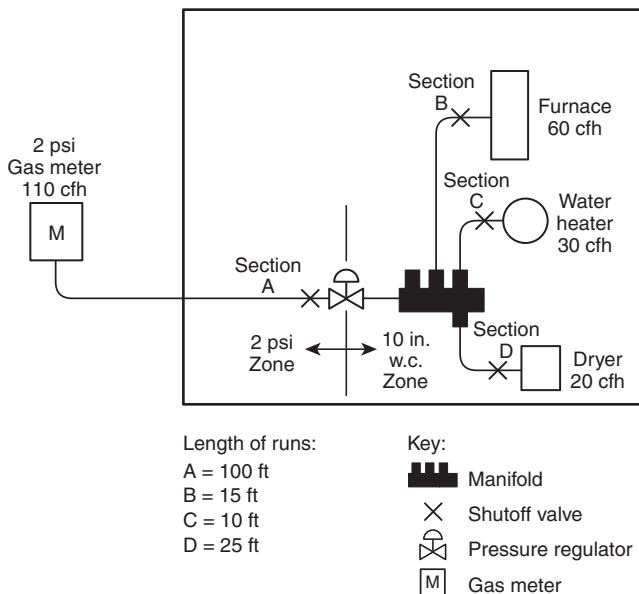

FIGURE B.7.2 Piping Plan Showing a CSST System.

- (5) From Section B (low-pressure zone):
 - (a) Distance from regulator to furnace is 15 ft (4.57 m).
 - (b) Load is 60 cfh (1.70 m³/hr).
 - (c) Table 6.2.1(p) shows that EHD size 13 should be used.
- (6) From Section C (low-pressure zone):
 - (a) Distance from regulator to water heater is 10 ft (3 m).
 - (b) Load is 30 cfh (0.85 m³/hr).
 - (c) Table 6.2.1(p) shows that EHD size 13 should be used.
- (7) From Section D (low-pressure zone):
 - (a) Distance from regulator to dryer is 25 ft (7.62 m).
 - (b) Load is 20 cfh (0.57 m³/hr).
 - (c) Table 6.2.1(p) shows that EHD size 13 should be used.

B.7.3 Example 3 — Branch Length Method. Determine the required semirigid copper tubing size of each section of the piping system shown in Figure B.7.3, with a designated pressure drop of 1 in. w.c. (250 Pa) (using the Branch Length Method). The gas to be used has 0.60 specific gravity and a heating value of 1000 Btu/ft³ (37.5 MJ/m³).

Solution

- (1) Section A:
 - (a) The length of tubing from the point of delivery to the most remote appliance is 50 ft (15 m), A + C.
 - (b) Use this longest length to size Sections A and C.
 - (c) Using the row marked 50 ft (15 m) in Table 6.2.1(j), Section A supplying 220 cfh (6.23 m³/hr) for four appliances requires 1 in. (25 mm) tubing.

- (2) Section B:
 - (a) The length of tubing from the point of delivery to the range/oven at the end of Section B is 30 ft (9.14 m), A + B.
 - (b) Use this branch length to size Section B only.
 - (c) Using the row marked 30 ft (9.14 m) in Table 6.2.1(j), Section B supplying 75 cfh (2.12 m³/hr) for the range/oven requires ½ in. (15 mm) tubing.
- (3) Section C:
 - (a) The length of tubing from the point of delivery to the dryer at the end of Section C is 50 ft (15 m), A + C.
 - (b) Use this branch length (which is also the longest length) to size Section C.
 - (c) Using the row marked 50 ft (15 m) in Table 6.2.1(j), Section C supplying 30 cfh (0.85 m³/hr) for the dryer requires ⅜ in. (10 mm) tubing.
- (4) Section D:
 - (a) The length of tubing from the point of delivery to the water heater at the end of Section D is 30 ft (9.14 m), A + D.
 - (b) Use this branch length to size Section D only.
 - (c) Using the row marked 30 ft (9.14 m) in Table 6.2.1(j), Section D supplying 35 cfh (34.69 m³/hr) for the water heater requires ⅜ in. (10 mm) tubing.
- (5) Section E:
 - (a) The length of tubing from the point of delivery to the furnace at the end of Section E is 30 ft (9.14 m), A + E.
 - (b) Use this branch length to size Section E only.
 - (c) Using the row marked 30 ft (9.14 m) in Table 6.2.1(j), Section E supplying 80 cfh (0.99 m³/hr) for the furnace requires ½ in. (15 mm) tubing.

B.7.4 Example 4 — Modification to Existing Piping System. Determine the required CSST size for Section G (retrofit application) of the piping system shown in Figure B.7.4, with a designated pressure drop of 0.50 in. w.c. (125 Pa) using the Branch Length Method. The gas to be used has 0.60 specific gravity and a heating value of 1000 Btu/ft³ (37.5 MJ/m³).

Solution

- (1) The length of pipe and CSST from the point of delivery to the retrofit appliance (barbecue) at the end of Section G is 40 ft (12.19 m), A + B + G.
- (2) Use this branch length to size Section G.
- (3) Assume the CSST manufacturer has tubing sizes or EHDs of 13, 18, 23, and 30.
- (4) Using the row marked 40 ft (12.19 m) in Table 6.2.1(o), Section G supplying 40 cfh (1.13 m³/hr) for the barbecue requires EHD 18 CSST.
- (5) The sizing of Sections A, B, F, and E must be checked to ensure adequate gas carrying capacity since an appliance has been added to the piping system. See B.7.1 for details.

B.7.5 Example 5 — Calculating Pressure Drops Due to Temperature Changes. A test piping system is installed on a warm autumn afternoon when the temperature is 70°F (21°C). In accordance with local custom, the new piping system is subjected to an air pressure test at 20 psi (138 kPa). Overnight, the temperature drops, and when the inspector shows up first thing in the morning the temperature is 40°F (4°C).

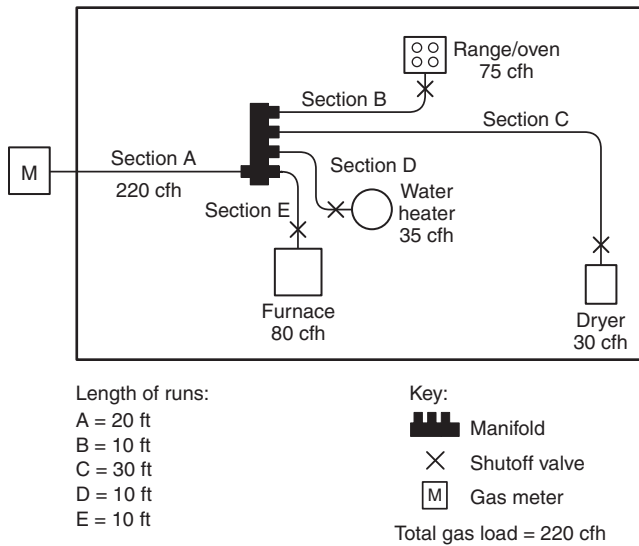

FIGURE B.7.3 Piping Plan Showing a Copper Tubing System.

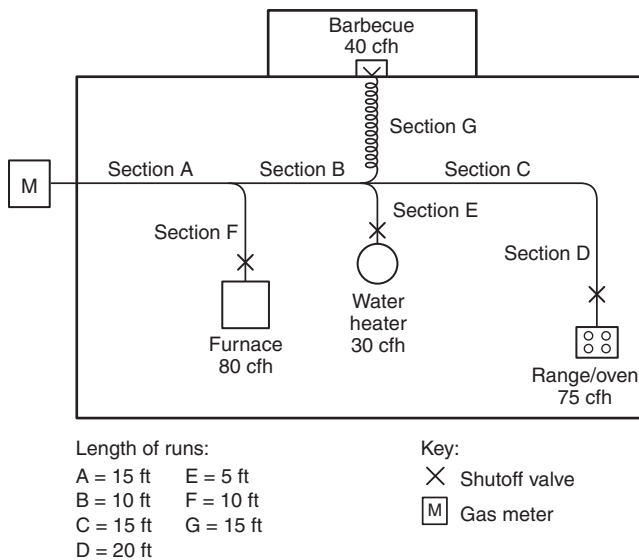

FIGURE B.7.4 Piping Plan Showing Modification to an Existing Piping System.

If the volume of the piping system is unchanged, the formula based on Boyle's and Charles' law for determining the new pressure at a reduced temperature is as follows:

$$(1) \quad \frac{T_1}{T_2} = \frac{P_1}{P_2} \quad [\text{B.7.5(1)}]$$

where:

T_1 = initial temperature [absolute ($T_1 + 459$)]

T_2 = final temperature [absolute ($T_2 + 459$)]

P_1 = initial pressure [psia ($P_1 + 14.7$)]

P_2 = final pressure [psia ($P_2 + 14.7$)]

$$(2) \quad \frac{(70 + 459)}{(40 + 459)} = \frac{(20 + 14.7)}{(P_2 + 14.7)} \quad [\text{B.7.5(2)}]$$

$$(3) \quad \frac{529}{499} = \frac{34.7}{(P_2 + 14.7)} \quad [\text{B.7.5(3)}]$$

$$(4) \quad (P_2 + 14.7) = \frac{34.7}{1.06} \quad [\text{B.7.5(4)}]$$

$$P_2 = 32.7 - 14.7$$

$$P_2 = 18 \text{ psi}$$

Therefore, you could expect the gauge to register 18 psi (124 kPa) when the ambient temperature is 40°F (4°C).

Δ B.7.6 Example 6 — Pressure Drop per 100 ft of Pipe Method.

Using the layout shown in Figure B.7.1 and ΔH = pressure drop, in. w.c. (27.7 in. H₂O = 1 psi), proceed as follows:

- (1) Length to A = 20 ft, with 35,000 Btu/hr:
 For ½ in. pipe:

$$\Delta H = \frac{20 \text{ ft}}{100 \text{ ft}} \times 0.3 \text{ in. w.c.} = 0.06 \text{ in. w.c.} \quad [\text{B.7.6(1)}]$$

- (2) Length to B = 15 ft, with 75,000 Btu/hr:
 For ¾ in. pipe:

$$\Delta H = \frac{15 \text{ ft}}{100 \text{ ft}} \times 0.3 \text{ in. w.c.} = 0.045 \text{ in. w.c.} \quad [\text{B.7.6(2)}]$$

- (3) Section 1 = 10 ft, with 110,000 Btu/hr. Here a choice is available:

For 1 in. pipe:

[B.7.6(3)a]

$$\Delta H = \frac{10 \text{ ft}}{100 \text{ ft}} \times 0.2 \text{ in. w.c.} = 0.02 \text{ in. w.c.}$$

For 3/4 in. pipe:

[B.7.6(3)b]

$$\Delta H = \frac{10 \text{ ft}}{100 \text{ ft}} \times \left[0.5 \text{ in. w.c.} + \left(\frac{110,000 \text{ Btu/hr} - 104,000 \text{ Btu/hr}}{147,000 \text{ Btu/hr} - 104,000 \text{ Btu/hr}} \right) \times (1.0 \text{ in. w.c.} - 0.5 \text{ in. w.c.}) \right]$$

$$= 0.1 \times 0.57 \text{ in. w.c.} \approx 0.06 \text{ in. w.c.}$$

Notice that the pressure drop for 110,000 Btu/hr between 104,000 Btu/hr and 147,000 Btu/hr has been interpolated.

- (4) Section 2 = 20 ft, with 135,000 Btu/hr. Here a choice is available:

For 1 in. pipe:

[B.7.6(4)a]

$$\Delta H = \frac{20 \text{ ft}}{100 \text{ ft}} \times \left[0.2 \text{ in. w.c.} + \frac{14,000 \text{ Btu/hr}}{27,000 \text{ Btu/hr}} \right]$$

$$\times \Delta 0.1 \text{ in. w.c.}$$

$$= 0.05 \text{ in. w.c.}$$

For 3/4 in. pipe:

[B.7.6(4)b]

$$H = \frac{20 \text{ ft}}{100 \text{ ft}} \times 1.0 \text{ in. w.c.} = 0.2 \text{ in. w.c.}$$

Notice that the pressure drop for 135,000 Btu/hr between 121,000 Btu/hr and 148,000 Btu/hr has been interpolated, but interpolation was not used for the 3/4 in. pipe (trivial for 104,000 Btu/hr to 147,000 Btu/hr).

- (5) Section 3 = 30 ft, with 245,000 Btu/hr. Here a choice is available:

For 1 in. pipe:

[B.7.6(5)a]

$$\Delta H = \frac{30 \text{ ft}}{100 \text{ ft}} \times 1.0 \text{ in. w.c.} = 0.3 \text{ in. w.c.}$$

For 1 1/4 in. pipe:

[B.7.6(5)b]

$$\Delta H = \frac{30 \text{ ft}}{100 \text{ ft}} \times 0.2 \text{ in. w.c.} = 0.06 \text{ in. w.c.}$$

Notice that interpolation was not used for these options, since the table values are close to the 245,000 Btu/hr carried by that section.

- (6) The total pressure drop is the sum of the section approaching A, Section 1, and Section 3, or either of the following, depending on whether an absolute minimum is required or the larger drop can be accommodated:

Minimum Pressure Drop to farthest appliance:

$$\Delta H = 0.06 \text{ in. w.c.} + 0.02 \text{ in. w.c.} + 0.06 \text{ in. w.c.} = 0.14 \text{ in. w.c.}$$

Larger Pressure Drop to the farthest appliance:

$$\Delta H = 0.06 \text{ in. w.c.} + 0.06 \text{ in. w.c.} + 0.3 \text{ in. w.c.} = 0.42 \text{ in. w.c.}$$

Notice that Section 2 and the run to B do not enter into this calculation, provided that the appliances have similar input pressure requirements.

For SI units, 1 Btu/hr = 0.293 W, 1 ft³ = 0.028 m³, 1 ft = 0.305 m, 1 in. w.c. = 249 Pa.

Annex C Suggested Method of Checking for Leakage

This annex is not a part of the requirements of this NFPA document but is included for informational purposes only.

C.1 Use of Lights. Artificial illumination used in connection with a search for gas leakage should be restricted to battery-operated flashlights (preferably of the safety type) or approved safety lamps. In searching for leaks, electric switches should not be operated. If electric lights are already turned on, they should not be turned off.

C.2 Leak Check Using the Gas Meter. Immediately prior to the leak check, it should be determined that the meter is in operating condition and has not been bypassed.

The leak check can be done by carefully watching the test dial of the meter to determine whether gas is passing through the meter. To assist in observing any movement of the test hand, wet a small piece of paper and paste its edge directly over the centerline of the hand as soon as the gas is turned on. This observation should be made with the test hand on the upstroke. Table C.2 can be used for determining the length of observation time.

In case careful observation of the test hand for a sufficient length of time reveals no movement, the piping should be purged and a small gas burner turned on and lighted and the hand of the test dial again observed. If the dial hand moves (as it should), it shows that the meter is operating properly. If the test hand does not move or register flow of gas through the meter to the small burner, the meter is defective and the gas should be shut off and the serving gas supplier notified.

Table C.2 Observation Times for Various Meter Dials

| Dial Styles (ft ³) | Test Time (min) |
|-----------------------------------|--------------------|
| 1/4 | 5 |
| 1/2 | 5 |
| 1 | 7 |
| 2 | 10 |
| 5 | 20 |
| 10 | 30 |

For SI units, 1 ft³ = 0.028 m³.

△ C.3 Leak Check Not Using a Meter. This test can be done using one of the following methods:

- (1) *For Any Gas System.*
 - (a) Attach a manometer or pressure gauge between the inlet to the piping system and the first regulator in the piping system, momentarily turn on the gas supply, and observe the gauging device for pressure drop with the gas supply shut off. No discernible drop in pressure should occur during a period of 3 minutes.
 - (b) Attach an in-line flow meter between the meter outlet and piping system inlet prior to the first regulator in the piping system. Slowly turn on the gas supply and observe the metering device. If flow does not drop to zero, leakage is indicated.
- (2) *For Gas Systems Using Undiluted LP-Gas System Preparation for Propane.* A leak check performed on an LP-Gas system being placed back in service can be performed by using one of the following methods:
 - (a) Insert a pressure gauge between the container gas shutoff valve and the first-stage regulator or integral two-stage regulator in the system, admitting full container pressure to the system and then closing the container shutoff valve. Enough gas should then be released from the system to lower the pressure gauge reading by 10 psi (69 kPa). The system should then be allowed to stand for 3 minutes without showing an increase or a decrease in the pressure gauge reading.
 - (b) Insert a gauge/regulator test assembly between the container gas shutoff valve and first-stage regulator or integral two-stage regulator in the system. If a gauge/regulator test assembly with an inches water column gauge is inserted, follow the test requirements in C.3(2)(c); if a gauge/regulator test assembly with a 30 psi gauge is inserted, follow the test requirements in C.3(2)(d).
 - (c) For systems with an integral two-stage, one or more second-stage, or one or more line pressure regulators serving appliances that receive gas at pressures of $\frac{1}{2}$ psi (3.5 kPa) or less, insert a water manometer or inches water column gauge into the system downstream of the final stage regulator, pressurizing the system with either fuel gas or air to a test pressure of 9 in. w.c. \pm $\frac{1}{2}$ in. w.c. (2.2 kPa \pm 0.1 kPa), and observing the device for a pressure change. If fuel gas is used as a pressure source, it is necessary to pressurize the system to full operating pressure, close the container service valve, and then release enough gas from the system through a range burner valve or other suitable means to drop the system pressure to 9 in. w.c. \pm $\frac{1}{2}$ in. w.c. (2.2 kPa \pm 0.1 kPa). This ensures that all regulators in the system upstream of the test point are unlocked and that a leak anywhere in the system is communicated to the gauging device. The gauging device should indicate no loss or gain of pressure for a period of 3 minutes.

- (d) When testing a system that has a first-stage regulator, or an integral two-stage regulator, insert a 30 psi (207 kPa) pressure gauge on the downstream side of the first-stage regulator or at the intermediate pressure tap of an integral two-stage regulator, admitting normal operating pressure to the system and then closing the container valve. Enough gas should be released from the system to lower the pressure gauge reading by a minimum of 2 psi (13.8 kPa) so that the first-stage regulator is unlocked. The system should be allowed to stand for 3 minutes without showing an increase or a decrease in pressure gauge reading.
- (e) Insert a gauge/regulator test assembly on the downstream side of the first stage regulator or at the intermediate pressure tap of an integral two stage regulator. If a gauge/regulator test assembly with an inches water column gauge is inserted, follow the test requirements in C.3(2)(c); if a gauge/regulator test assembly with a 30 psi gauge is inserted, follow the test requirements in C.3(2)(d).

C.4 When Leakage Is Indicated. If leakage is indicated by a test device, all appliances and equipment or outlets supplied through the system should be examined to see whether they are shut off and do not leak. If they are found to be tight, the piping system has a leak.

Annex D Suggested Emergency Procedure for Gas Leaks

This annex is not a part of the requirements of this NFPA document but is included for informational purposes only.

D.1 Where an investigation discloses a concentration of gas inside of a building, it is suggested the following immediate actions be taken:

- (1) Clear the room, building, or area of all occupants. Do not re-enter the room, building, or area until the space has been determined to be safe.
- (2) Use every practical means to eliminate sources of ignition. Take precautions to prevent smoking, striking matches, operating electrical switches or devices, opening furnace doors, and so on. If possible, cut off all electric circuits at a remote source to eliminate operation of automatic switches in the dangerous area. Safety flashlights designed for use in hazardous atmospheres are recommended for use in such emergencies.
- (3) Notify all personnel in the area and the gas supplier from a telephone remote from the area of the leak.
- (4) Ventilate the affected portion of the building by opening windows and doors.
- (5) Shut off the supply of gas to the areas involved.
- (6) Investigate other buildings in the immediate area to determine the presence of escaping gas therein.

Annex E Flow of Gas Through Fixed Orifices

This annex is not a part of the requirements of this NFPA document but is included for informational purposes only.

E.1 Use of Orifice Tables.

E.1.1 To Check Burner Input Not Using a Meter. Gauge the size of the burner orifice and determine flow rate at sea level from Table E.1.1(a), Utility Gases (cubic feet per hour), or from Table E.1.1(b), LP-Gases (Btu per hour). When the specific gravity of the utility gas is other than 0.60, select the

multiplier from Table E.1.1(c) for the specific gravity of the utility gas served and apply to the flow rate as determined from Table E.1.1(a). When the altitude is above 2000 ft (600 m), first select the equivalent orifice size at sea level using Table E.1.1(d), then determine the flow rate from Table E.1.1(a) or Table E.1.1(b) as directed. Having determined the flow rate (as adjusted for specific gravity and/or altitude where necessary), check the burner input at sea level with the manufacturer's rated input.

Table E.1.1(a) Utility Gases (cubic feet per hour at sea level)

| Orifice or Drill Size | Pressure at Orifice (in. w.c.) | | | | | | | | |
|--------------------------------|--------------------------------|-------|-------|-------|-------|-------|-------|-------|-------|
| | 3 | 3.5 | 4 | 5 | 6 | 7 | 8 | 9 | 10 |
| 80 | 0.48 | 0.52 | 0.55 | 0.63 | 0.69 | 0.73 | 0.79 | 0.83 | 0.88 |
| 79 | 0.55 | 0.59 | 0.64 | 0.72 | 0.80 | 0.84 | 0.90 | 0.97 | 1.01 |
| 78 | 0.70 | 0.76 | 0.78 | 0.88 | 0.97 | 1.04 | 1.10 | 1.17 | 1.24 |
| 77 | 0.88 | 0.95 | 0.99 | 1.11 | 1.23 | 1.31 | 1.38 | 1.47 | 1.55 |
| 76 | 1.05 | 1.13 | 1.21 | 1.37 | 1.52 | 1.61 | 1.72 | 1.83 | 1.92 |
| 75 | 1.16 | 1.25 | 1.34 | 1.52 | 1.64 | 1.79 | 1.91 | 2.04 | 2.14 |
| 74 | 1.33 | 1.44 | 1.55 | 1.74 | 1.91 | 2.05 | 2.18 | 2.32 | 2.44 |
| 73 | 1.51 | 1.63 | 1.76 | 1.99 | 2.17 | 2.32 | 2.48 | 2.64 | 2.78 |
| 72 | 1.64 | 1.77 | 1.90 | 2.15 | 2.40 | 2.52 | 2.69 | 2.86 | 3.00 |
| 71 | 1.82 | 1.97 | 2.06 | 2.33 | 2.54 | 2.73 | 2.91 | 3.11 | 3.26 |
| 70 | 2.06 | 2.22 | 2.39 | 2.70 | 2.97 | 3.16 | 3.38 | 3.59 | 3.78 |
| 69 | 2.25 | 2.43 | 2.61 | 2.96 | 3.23 | 3.47 | 3.68 | 3.94 | 4.14 |
| 68 | 2.52 | 2.72 | 2.93 | 3.26 | 3.58 | 3.88 | 4.14 | 4.41 | 4.64 |
| 67 | 2.69 | 2.91 | 3.12 | 3.52 | 3.87 | 4.13 | 4.41 | 4.69 | 4.94 |
| 66 | 2.86 | 3.09 | 3.32 | 3.75 | 4.11 | 4.39 | 4.68 | 4.98 | 5.24 |
| 65 | 3.14 | 3.39 | 3.72 | 4.28 | 4.62 | 4.84 | 5.16 | 5.50 | 5.78 |
| 64 | 3.41 | 3.68 | 4.14 | 4.48 | 4.91 | 5.23 | 5.59 | 5.95 | 6.26 |
| 63 | 3.63 | 3.92 | 4.19 | 4.75 | 5.19 | 5.55 | 5.92 | 6.30 | 6.63 |
| 62 | 3.78 | 4.08 | 4.39 | 4.96 | 5.42 | 5.81 | 6.20 | 6.59 | 6.94 |
| 61 | 4.02 | 4.34 | 4.66 | 5.27 | 5.77 | 6.15 | 6.57 | 7.00 | 7.37 |
| 60 | 4.21 | 4.55 | 4.89 | 5.52 | 5.95 | 6.47 | 6.91 | 7.35 | 7.74 |
| 59 | 4.41 | 4.76 | 5.11 | 5.78 | 6.35 | 6.78 | 7.25 | 7.71 | 8.11 |
| 58 | 4.66 | 5.03 | 5.39 | 6.10 | 6.68 | 7.13 | 7.62 | 8.11 | 8.53 |
| 57 | 4.84 | 5.23 | 5.63 | 6.36 | 6.96 | 7.44 | 7.94 | 8.46 | 8.90 |
| 56 | 5.68 | 6.13 | 6.58 | 7.35 | 8.03 | 8.73 | 9.32 | 9.92 | 10.44 |
| 55 | 7.11 | 7.68 | 8.22 | 9.30 | 10.18 | 10.85 | 11.59 | 12.34 | 12.98 |
| 54 | 7.95 | 8.59 | 9.23 | 10.45 | 11.39 | 12.25 | 13.08 | 13.93 | 14.65 |
| 53 | 9.30 | 10.04 | 10.80 | 12.20 | 13.32 | 14.29 | 15.27 | 16.25 | 17.09 |
| 52 | 10.61 | 11.46 | 12.31 | 13.86 | 15.26 | 16.34 | 17.44 | 18.57 | 19.53 |
| 51 | 11.82 | 12.77 | 13.69 | 15.47 | 16.97 | 18.16 | 19.40 | 20.64 | 21.71 |
| 50 | 12.89 | 13.92 | 14.94 | 16.86 | 18.48 | 19.77 | 21.12 | 22.48 | 23.65 |
| 49 | 14.07 | 15.20 | 16.28 | 18.37 | 20.20 | 21.60 | 23.06 | 24.56 | 25.83 |
| 48 | 15.15 | 16.36 | 17.62 | 19.88 | 21.81 | 23.31 | 24.90 | 26.51 | 27.89 |
| 47 | 16.22 | 17.52 | 18.80 | 21.27 | 23.21 | 24.93 | 26.62 | 28.34 | 29.81 |
| 46 | 17.19 | 18.57 | 19.98 | 22.57 | 24.72 | 26.43 | 28.23 | 30.05 | 31.61 |
| 45 | 17.73 | 19.15 | 20.52 | 23.10 | 25.36 | 27.18 | 29.03 | 30.90 | 32.51 |
| 44 | 19.45 | 21.01 | 22.57 | 25.57 | 27.93 | 29.87 | 31.89 | 33.96 | 35.72 |
| 43 | 20.73 | 22.39 | 24.18 | 27.29 | 29.87 | 32.02 | 34.19 | 36.41 | 38.30 |
| 42 | 23.10 | 24.95 | 26.50 | 29.50 | 32.50 | 35.24 | 37.63 | 40.07 | 42.14 |
| 41 | 24.06 | 25.98 | 28.15 | 31.69 | 34.81 | 37.17 | 39.70 | 42.27 | 44.46 |

(continues)

△ Table E.1.1(a) *Continued*

| Orifice or Drill Size | Pressure at Orifice (in. w.c.) | | | | | | | | |
|--------------------------------|--------------------------------|--------|--------|--------|--------|--------|--------|--------|--------|
| | 3 | 3.5 | 4 | 5 | 6 | 7 | 8 | 9 | 10 |
| 40 | 25.03 | 27.03 | 29.23 | 33.09 | 36.20 | 38.79 | 41.42 | 44.10 | 46.38 |
| 39 | 26.11 | 28.20 | 30.20 | 34.05 | 37.38 | 39.97 | 42.68 | 45.44 | 47.80 |
| 38 | 27.08 | 29.25 | 31.38 | 35.46 | 38.89 | 41.58 | 44.40 | 47.27 | 49.73 |
| 37 | 28.36 | 30.63 | 32.99 | 37.07 | 40.83 | 43.62 | 46.59 | 49.60 | 52.17 |
| 36 | 29.76 | 32.14 | 34.59 | 39.11 | 42.76 | 45.77 | 48.88 | 52.04 | 54.74 |
| 35 | 32.36 | 34.95 | 36.86 | 41.68 | 45.66 | 48.78 | 52.10 | 55.46 | 58.34 |
| 34 | 32.45 | 35.05 | 37.50 | 42.44 | 46.52 | 49.75 | 53.12 | 56.55 | 59.49 |
| 33 | 33.41 | 36.08 | 38.79 | 43.83 | 48.03 | 51.46 | 54.96 | 58.62 | 61.55 |
| 32 | 35.46 | 38.30 | 40.94 | 46.52 | 50.82 | 54.26 | 57.95 | 61.70 | 64.89 |
| 31 | 37.82 | 40.85 | 43.83 | 49.64 | 54.36 | 58.01 | 61.96 | 65.97 | 69.39 |
| 30 | 43.40 | 46.87 | 50.39 | 57.05 | 62.09 | 66.72 | 71.22 | 75.86 | 79.80 |
| 29 | 48.45 | 52.33 | 56.19 | 63.61 | 69.62 | 74.45 | 79.52 | 84.66 | 89.04 |
| 28 | 51.78 | 55.92 | 59.50 | 67.00 | 73.50 | 79.50 | 84.92 | 90.39 | 95.09 |
| 27 | 54.47 | 58.83 | 63.17 | 71.55 | 78.32 | 83.59 | 89.27 | 95.04 | 99.97 |
| 26 | 56.73 | 61.27 | 65.86 | 74.57 | 81.65 | 87.24 | 93.17 | 99.19 | 104.57 |
| 25 | 58.87 | 63.58 | 68.22 | 77.14 | 84.67 | 90.36 | 96.50 | 102.74 | 108.07 |
| 24 | 60.81 | 65.67 | 70.58 | 79.83 | 87.56 | 93.47 | 99.83 | 106.28 | 111.79 |
| 23 | 62.10 | 67.07 | 72.20 | 81.65 | 89.39 | 94.55 | 100.98 | 107.49 | 113.07 |
| 22 | 64.89 | 70.08 | 75.21 | 85.10 | 93.25 | 99.60 | 106.39 | 113.24 | 119.12 |
| 21 | 66.51 | 71.83 | 77.14 | 87.35 | 95.63 | 102.29 | 109.24 | 116.29 | 122.33 |
| 20 | 68.22 | 73.68 | 79.08 | 89.49 | 97.99 | 104.75 | 111.87 | 119.10 | 125.28 |
| 19 | 72.20 | 77.98 | 83.69 | 94.76 | 103.89 | 110.67 | 118.55 | 125.82 | 132.36 |
| 18 | 75.53 | 81.57 | 87.56 | 97.50 | 108.52 | 116.03 | 123.92 | 131.93 | 138.78 |
| 17 | 78.54 | 84.82 | 91.10 | 103.14 | 112.81 | 120.33 | 128.52 | 136.82 | 143.91 |
| 16 | 82.19 | 88.77 | 95.40 | 107.98 | 118.18 | 126.78 | 135.39 | 144.15 | 151.63 |
| 15 | 85.20 | 92.02 | 98.84 | 111.74 | 122.48 | 131.07 | 139.98 | 149.03 | 156.77 |
| 14 | 87.10 | 94.40 | 100.78 | 114.21 | 124.44 | 133.22 | 142.28 | 151.47 | 159.33 |
| 13 | 89.92 | 97.11 | 104.32 | 118.18 | 128.93 | 138.60 | 148.02 | 157.58 | 165.76 |
| 12 | 93.90 | 101.41 | 108.52 | 123.56 | 135.37 | 143.97 | 153.75 | 163.69 | 172.13 |
| 11 | 95.94 | 103.62 | 111.31 | 126.02 | 137.52 | 147.20 | 157.20 | 167.36 | 176.03 |
| 10 | 98.30 | 106.16 | 114.21 | 129.25 | 141.82 | 151.50 | 161.81 | 172.26 | 181.13 |
| 9 | 100.99 | 109.07 | 117.11 | 132.58 | 145.05 | 154.71 | 165.23 | 175.91 | 185.03 |
| 8 | 103.89 | 112.20 | 120.65 | 136.44 | 149.33 | 160.08 | 170.96 | 182.00 | 191.44 |
| 7 | 105.93 | 114.40 | 123.01 | 139.23 | 152.56 | 163.31 | 174.38 | 185.68 | 195.30 |
| 6 | 109.15 | 117.88 | 126.78 | 142.88 | 156.83 | 167.51 | 178.88 | 190.46 | 200.36 |
| 5 | 111.08 | 119.97 | 128.93 | 145.79 | 160.08 | 170.82 | 182.48 | 194.22 | 204.30 |
| 4 | 114.75 | 123.93 | 133.22 | 150.41 | 164.36 | 176.18 | 188.16 | 200.25 | 210.71 |
| 3 | 119.25 | 128.79 | 137.52 | 156.26 | 170.78 | 182.64 | 195.08 | 207.66 | 218.44 |
| 2 | 128.48 | 138.76 | 148.61 | 168.64 | 184.79 | 197.66 | 211.05 | 224.74 | 235.58 |
| 1 | 136.35 | 147.26 | 158.25 | 179.33 | 194.63 | 209.48 | 223.65 | 238.16 | 250.54 |

For SI units, 1 Btu/hr = 0.293 W, 1 ft³ = 0.028 m³, 1 ft = 0.305 m, 1 in. w.c. = 249 Pa.

Notes:

(1) Specific gravity = 0.60; orifice coefficient = 0.90.

(2) For utility gases of another specific gravity, select multiplier from Table E.1.1(c). For altitudes above 2000 ft, first select the equivalent orifice size at sea level from Table E.1.1(d).

Table E.1.1(b) LP-Gases (Btu per hour at sea level)

| Orifice or Drill Size | Propane | Butane |
|-----------------------------|---------|---------|
| 0.008 | 519 | 589 |
| 0.009 | 656 | 744 |
| 0.010 | 812 | 921 |
| 0.011 | 981 | 1,112 |
| 0.012 | 1,169 | 1,326 |
| 80 | 1,480 | 1,678 |
| 79 | 1,708 | 1,936 |
| 78 | 2,080 | 2,358 |
| 77 | 2,629 | 2,980 |
| 76 | 3,249 | 3,684 |
| 75 | 3,581 | 4,059 |
| 74 | 4,119 | 4,669 |
| 73 | 4,678 | 5,303 |
| 72 | 5,081 | 5,760 |
| 71 | 5,495 | 6,230 |
| 70 | 6,375 | 7,227 |
| 69 | 6,934 | 7,860 |
| 68 | 7,813 | 8,858 |
| 67 | 8,320 | 9,433 |
| 66 | 8,848 | 10,031 |
| 65 | 9,955 | 11,286 |
| 64 | 10,535 | 11,943 |
| 63 | 11,125 | 12,612 |
| 62 | 11,735 | 13,304 |
| 61 | 12,367 | 14,020 |
| 60 | 13,008 | 14,747 |
| 59 | 13,660 | 15,486 |
| 58 | 14,333 | 16,249 |
| 57 | 15,026 | 17,035 |
| 56 | 17,572 | 19,921 |
| 55 | 21,939 | 24,872 |
| 54 | 24,630 | 27,922 |
| 53 | 28,769 | 32,615 |
| 52 | 32,805 | 37,190 |
| 51 | 36,531 | 41,414 |
| 50 | 39,842 | 45,168 |
| 49 | 43,361 | 49,157 |
| 48 | 46,983 | 53,263 |
| 47 | 50,088 | 56,783 |
| 46 | 53,296 | 60,420 |
| 45 | 54,641 | 61,944 |
| 44 | 60,229 | 68,280 |
| 43 | 64,369 | 72,973 |
| 42 | 71,095 | 80,599 |
| 41 | 74,924 | 84,940 |
| 40 | 78,029 | 88,459 |
| 39 | 80,513 | 91,215 |
| 38 | 83,721 | 94,912 |
| 37 | 87,860 | 99,605 |
| 36 | 92,207 | 104,532 |

(continues)

Δ Table E.1.1(b) *Continued*

| Orifice or Drill Size | Propane | Butane |
|-----------------------------|---------|---------|
| 35 | 98,312 | 111,454 |
| 34 | 100,175 | 113,566 |
| 33 | 103,797 | 117,672 |
| 32 | 109,385 | 124,007 |
| 31 | 117,043 | 132,689 |
| 30 | 134,119 | 152,046 |
| 29 | 150,366 | 170,466 |
| 28 | 160,301 | 181,728 |
| 27 | 168,580 | 191,114 |
| 26 | 175,617 | 199,092 |
| 25 | 181,619 | 205,896 |
| 24 | 187,828 | 212,935 |
| 23 | 192,796 | 218,567 |
| 22 | 200,350 | 227,131 |
| 21 | 205,525 | 232,997 |
| 20 | 210,699 | 238,863 |
| 19 | 223,945 | 253,880 |
| 18 | 233,466 | 264,673 |

Notes:

- | | Propane | Butane |
|------------------------------------|---------|--------|
| (1) Btu per cubic foot | 2516 | 3280 |
| (2) Specific gravity | 1.52 | 2.01 |
| (3) Pressure at orifice (in. w.c.) | 11 | 11 |
| (4) Orifice coefficient | 0.9 | 0.9 |
- (5) For altitudes above 2000 ft (610 m), first select the equivalent orifice size at sea level from Table E.1.1(d).

Table E.1.1(c) Multipliers for Utility Gases of Another Specific Gravity

| Specific Gravity | Multiplier | Specific Gravity | Multiplier |
|------------------|------------|------------------|------------|
| 0.45 | 1.155 | 0.95 | 0.795 |
| 0.50 | 1.095 | 1.00 | 0.775 |
| 0.55 | 1.045 | 1.05 | 0.756 |
| 0.60 | 1.000 | 1.10 | 0.739 |
| 0.65 | 0.961 | 1.15 | 0.722 |
| 0.70 | 0.926 | 1.20 | 0.707 |
| 0.75 | 0.894 | 1.25 | 0.693 |
| 0.80 | 0.866 | 1.30 | 0.679 |
| 0.85 | 0.840 | 1.35 | 0.667 |
| 0.90 | 0.817 | 1.40 | 0.655 |

Table E.1.1(d) Equivalent Orifice Sizes at High Altitudes (includes 4% input reduction for each 1000 ft above sea level)

| Orifice Size at Sea Level | Orifice Size Required at Other Elevations (ft) | | | | | | | | |
|---------------------------|------------------------------------------------|------|------|------|------|------|------|------|--------|
| | 2000 | 3000 | 4000 | 5000 | 6000 | 7000 | 8000 | 9000 | 10,000 |
| 1 | 2 | 2 | 3 | 3 | 4 | 5 | 7 | 8 | 10 |
| 2 | 3 | 3 | 4 | 5 | 6 | 7 | 9 | 10 | 12 |
| 3 | 4 | 5 | 7 | 8 | 9 | 10 | 12 | 13 | 15 |
| 4 | 6 | 7 | 8 | 9 | 11 | 12 | 13 | 14 | 16 |
| 5 | 7 | 8 | 9 | 10 | 12 | 13 | 14 | 15 | 17 |
| 6 | 8 | 9 | 10 | 11 | 12 | 13 | 14 | 16 | 17 |
| 7 | 9 | 10 | 11 | 12 | 13 | 14 | 15 | 16 | 18 |
| 8 | 10 | 11 | 12 | 13 | 13 | 15 | 16 | 17 | 18 |
| 9 | 11 | 12 | 12 | 13 | 14 | 16 | 17 | 18 | 19 |
| 10 | 12 | 13 | 13 | 14 | 15 | 16 | 17 | 18 | 19 |
| 11 | 13 | 13 | 14 | 15 | 16 | 17 | 18 | 19 | 20 |
| 12 | 13 | 14 | 15 | 16 | 17 | 17 | 18 | 19 | 20 |
| 13 | 15 | 15 | 16 | 17 | 18 | 18 | 19 | 20 | 22 |
| 14 | 16 | 16 | 17 | 18 | 18 | 19 | 20 | 21 | 23 |
| 15 | 16 | 17 | 17 | 18 | 19 | 20 | 20 | 22 | 24 |
| 16 | 17 | 18 | 18 | 19 | 19 | 20 | 22 | 23 | 25 |
| 17 | 18 | 19 | 19 | 20 | 21 | 22 | 23 | 24 | 26 |
| 18 | 19 | 19 | 20 | 21 | 22 | 23 | 24 | 26 | 27 |
| 19 | 20 | 20 | 21 | 22 | 23 | 25 | 26 | 27 | 28 |
| 20 | 22 | 22 | 23 | 24 | 25 | 26 | 27 | 28 | 29 |
| 21 | 23 | 23 | 24 | 25 | 26 | 27 | 28 | 28 | 29 |
| 22 | 23 | 24 | 25 | 26 | 27 | 27 | 28 | 29 | 29 |
| 23 | 25 | 25 | 26 | 27 | 27 | 28 | 29 | 29 | 30 |
| 24 | 25 | 26 | 27 | 27 | 28 | 28 | 29 | 29 | 30 |
| 25 | 26 | 27 | 27 | 28 | 28 | 29 | 29 | 30 | 30 |
| 26 | 27 | 28 | 28 | 28 | 29 | 29 | 30 | 30 | 30 |
| 27 | 28 | 28 | 29 | 29 | 29 | 30 | 30 | 30 | 31 |
| 28 | 29 | 29 | 29 | 30 | 30 | 30 | 30 | 31 | 31 |
| 29 | 29 | 30 | 30 | 30 | 30 | 31 | 31 | 31 | 32 |
| 30 | 30 | 31 | 31 | 31 | 31 | 32 | 32 | 33 | 35 |
| 31 | 32 | 32 | 32 | 33 | 34 | 35 | 36 | 37 | 38 |
| 32 | 33 | 34 | 35 | 35 | 36 | 36 | 37 | 38 | 40 |
| 33 | 35 | 35 | 36 | 36 | 37 | 38 | 38 | 40 | 41 |
| 34 | 35 | 36 | 36 | 37 | 37 | 38 | 39 | 40 | 42 |
| 35 | 36 | 36 | 37 | 37 | 38 | 39 | 40 | 41 | 42 |
| 36 | 37 | 38 | 38 | 39 | 40 | 41 | 41 | 42 | 43 |
| 37 | 38 | 39 | 39 | 40 | 41 | 42 | 42 | 43 | 43 |
| 38 | 39 | 40 | 41 | 41 | 42 | 42 | 43 | 43 | 44 |
| 39 | 40 | 41 | 41 | 42 | 42 | 43 | 43 | 44 | 44 |
| 40 | 41 | 42 | 42 | 42 | 43 | 43 | 44 | 44 | 45 |
| 41 | 42 | 42 | 42 | 43 | 43 | 44 | 44 | 45 | 46 |
| 42 | 42 | 43 | 43 | 43 | 44 | 44 | 45 | 46 | 47 |
| 43 | 44 | 44 | 44 | 45 | 45 | 46 | 47 | 47 | 48 |
| 44 | 45 | 45 | 45 | 46 | 47 | 47 | 48 | 48 | 49 |
| 45 | 46 | 47 | 47 | 47 | 48 | 48 | 49 | 49 | 50 |
| 46 | 47 | 47 | 47 | 48 | 48 | 49 | 49 | 50 | 50 |
| 47 | 48 | 48 | 49 | 49 | 49 | 50 | 50 | 51 | 51 |
| 48 | 49 | 49 | 49 | 50 | 50 | 50 | 51 | 51 | 52 |
| 49 | 50 | 50 | 50 | 51 | 51 | 51 | 52 | 52 | 52 |
| 50 | 51 | 51 | 51 | 51 | 52 | 52 | 52 | 53 | 53 |

(continues)

Table E.1.1(d) *Continued*

| Orifice Size at Sea Level | Orifice Size Required at Other Elevations (ft) | | | | | | | | |
|---------------------------|------------------------------------------------|-------|-------|-------|-------|-------|-------|-------|--------|
| | 2000 | 3000 | 4000 | 5000 | 6000 | 7000 | 8000 | 9000 | 10,000 |
| 51 | 51 | 52 | 52 | 52 | 52 | 53 | 53 | 53 | 54 |
| 52 | 52 | 53 | 53 | 53 | 53 | 53 | 54 | 54 | 54 |
| 53 | 54 | 54 | 54 | 54 | 54 | 54 | 55 | 55 | 55 |
| 54 | 54 | 55 | 55 | 55 | 55 | 55 | 56 | 56 | 56 |
| 55 | 55 | 55 | 55 | 56 | 56 | 56 | 56 | 56 | 57 |
| 56 | 56 | 56 | 57 | 57 | 57 | 58 | 59 | 59 | 60 |
| 57 | 58 | 59 | 59 | 60 | 60 | 61 | 62 | 63 | 63 |
| 58 | 59 | 60 | 60 | 61 | 62 | 62 | 63 | 63 | 64 |
| 59 | 60 | 61 | 61 | 62 | 62 | 63 | 64 | 64 | 65 |
| 60 | 61 | 61 | 62 | 63 | 63 | 64 | 64 | 65 | 65 |
| 61 | 62 | 62 | 63 | 63 | 64 | 65 | 65 | 66 | 66 |
| 62 | 63 | 63 | 64 | 64 | 65 | 65 | 66 | 66 | 67 |
| 63 | 64 | 64 | 65 | 65 | 65 | 66 | 66 | 67 | 68 |
| 64 | 65 | 65 | 65 | 66 | 66 | 66 | 67 | 67 | 68 |
| 65 | 65 | 66 | 66 | 66 | 67 | 67 | 68 | 68 | 69 |
| 66 | 67 | 67 | 68 | 68 | 68 | 69 | 69 | 69 | 70 |
| 67 | 68 | 68 | 68 | 69 | 69 | 69 | 70 | 70 | 70 |
| 68 | 68 | 69 | 69 | 69 | 70 | 70 | 70 | 71 | 71 |
| 69 | 70 | 70 | 70 | 70 | 71 | 71 | 71 | 72 | 72 |
| 70 | 70 | 71 | 71 | 71 | 71 | 72 | 72 | 73 | 73 |
| 71 | 72 | 72 | 72 | 73 | 73 | 73 | 74 | 74 | 74 |
| 72 | 73 | 73 | 73 | 73 | 74 | 74 | 74 | 74 | 75 |
| 73 | 73 | 74 | 74 | 74 | 74 | 75 | 75 | 75 | 76 |
| 74 | 74 | 75 | 75 | 75 | 75 | 76 | 76 | 76 | 76 |
| 75 | 75 | 76 | 76 | 76 | 76 | 77 | 77 | 77 | 77 |
| 76 | 76 | 76 | 77 | 77 | 77 | 77 | 77 | 77 | 77 |
| 77 | 77 | 77 | 77 | 78 | 78 | 78 | 78 | 78 | 78 |
| 78 | 78 | 78 | 78 | 79 | 79 | 79 | 79 | 80 | 80 |
| 79 | 79 | 80 | 80 | 80 | 80 | 0.013 | 0.012 | 0.012 | 0.01 |
| 80 | 80 | 0.013 | 0.013 | 0.013 | 0.012 | 0.012 | 0.012 | 0.012 | 0.011 |

For SI units, 1 ft = 0.305 m.

E.1.2 To Select Correct Orifice Size for Rated Burner Input.

The selection of a fixed orifice size for any rated burner input is affected by many variables, including orifice coefficient, and it is recommended that the appliance manufacturer be consulted for that purpose. When the correct orifice size cannot be readily determined, the orifice flow rates, as stated in the tables in this annex, can be used to select a fixed orifice size with a flow rate to approximately equal the required rated burner input.

For gases of the specific gravity and pressure conditions stipulated at elevations under 2000 ft (600 m), Table E.1.1(a) (in cubic feet per hour) or Table E.1.1(b) (in Btu per hour) can be used directly.

Where the specific gravity of the gas is other than 0.60, select the multiplier from Table E.1.1(c) for the utility gas served and divide the rated burner input by the selected factor to determine equivalent input at a specific gravity of 0.60, then select orifice size.

Where the appliance is located at an altitude of 2000 ft (600 m) or above, first use the manufacturer's rated input at sea level to select the orifice size as directed, then use Table

E.1.1(d) to select the equivalent orifice size for use at the higher altitude.

Annex F Sizing of Venting Systems Serving Appliances Equipped with Draft Hoods, Category I Appliances, and Appliances Listed for Use with Type B Vents

This annex is not a part of the requirements of this NFPA document but is included for informational purposes only.

For SI units, 1 Btu/hr = 0.293 W, 1 ft³ = 0.028 m³, 1 ft = 0.305 m, 1 in. w.c. = 249 Pa.

F.1 Examples Using Single Appliance Venting Tables. See Figure F.1(a) through Figure F.1(n).

F.1.1 Example 1: Single Draft Hood-Equipped Appliance. An installer has a 120,000 Btu/hr input appliance with a 5 in. diameter draft hood outlet that needs to be vented into a 10 ft high Type B vent system. What size vent should be used assuming (1) a 5 ft lateral single-wall metal vent connector is used with two 90 degree elbows or (2) a 5 ft lateral single-wall metal vent connector is used with three 90-degree elbows in the vent system? See Figure F.1.1.

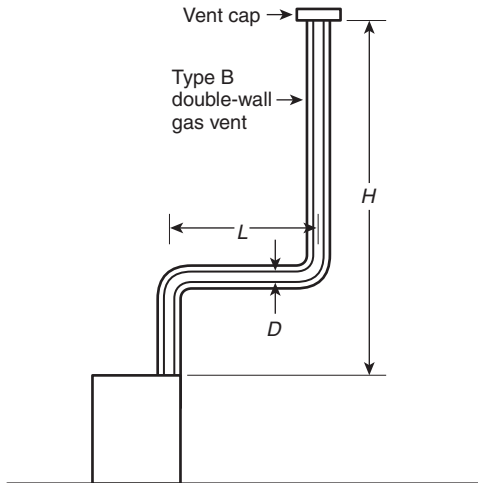

Table 13.1(a) is used when sizing Type B double-wall gas vent connected directly to the appliance.

Note: The appliance can be either Category I draft hood-equipped or fan-assisted type.

▲ FIGURE F.1(a) Type B Double-Wall Vent System Serving a Single Appliance with a Type B Double-Wall Vent.

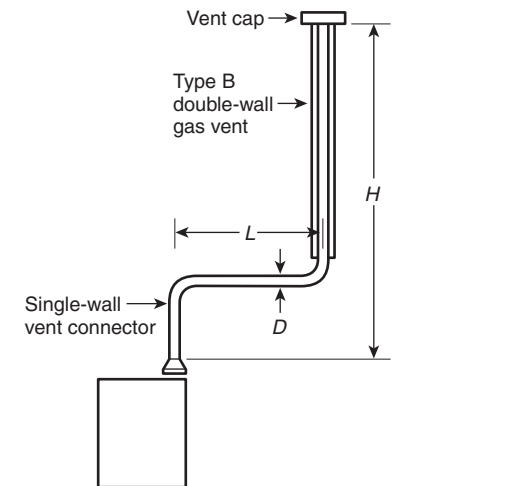

Table 13.1(b) is used when sizing a single-wall metal vent connector attached to a Type B double-wall gas vent.

Note: The appliance can be either Category I draft hood-equipped or fan-assisted type.

▲ FIGURE F.1(b) Type B Double-Wall Vent System Serving a Single Appliance with a Single-Wall Metal Vent Connector.

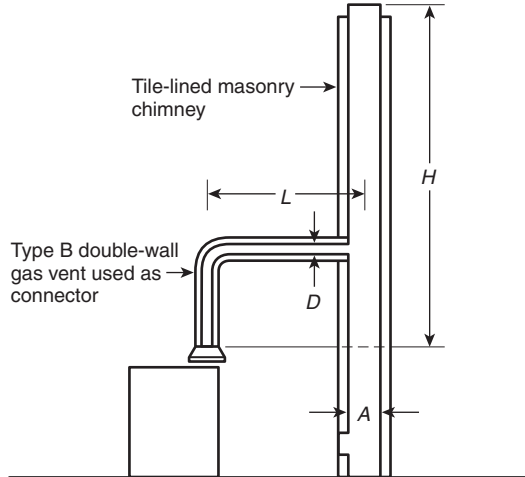

Table 13.1(c) is used when sizing a Type B double-wall gas vent connector attached to a tile-lined masonry chimney.

Notes:

- (1) A is the equivalent cross-sectional area of the tile liner.
- (2) The appliance can be either Category I draft hood-equipped or fan-assisted type.

▲ FIGURE F.1(c) Vent System Serving a Single Appliance with a Masonry Chimney and a Type B Double-Wall Vent Connector.

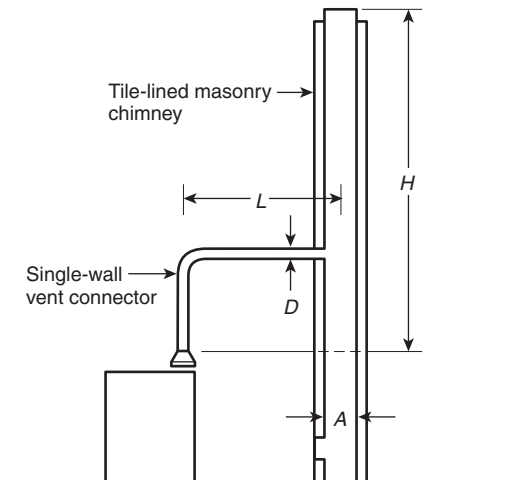
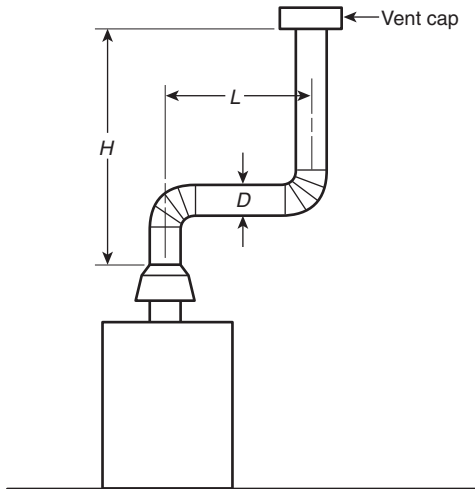

Table 13.1(d) is used when sizing a single-wall vent connector attached to a tile-lined masonry chimney.

Notes:

- (1) A is the equivalent cross-sectional area of the tile liner.
- (2) The appliance can be either Category I draft hood-equipped or fan-assisted type.

▲ FIGURE F.1(d) Vent System Serving a Single Appliance Using a Masonry Chimney and a Single-Wall Metal Vent Connector.



Asbestos cement Type B or single-wall metal vent serving a single draft hood-equipped appliance. [See Table 13.1(e).]

▲ FIGURE F.1(e) Asbestos Cement Type B or Single-Wall Metal Vent System Serving a Single Draft Hood-Equipped Appliance.

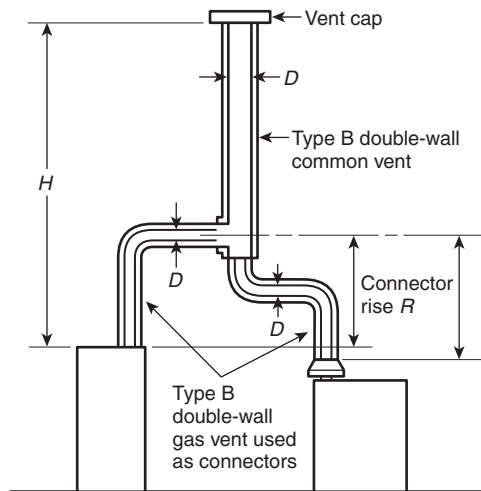

Table 13.2(a) is used when sizing Type B double-wall gas vent connectors attached to a Type B double-wall common vent.

Note: Each appliance can be either Category I draft hood-equipped or fan-assisted type.

▲ FIGURE F.1(f) Vent System Serving Two or More Appliances with Type B Double-Wall Vent and Type B Double-Wall Vent Connectors.

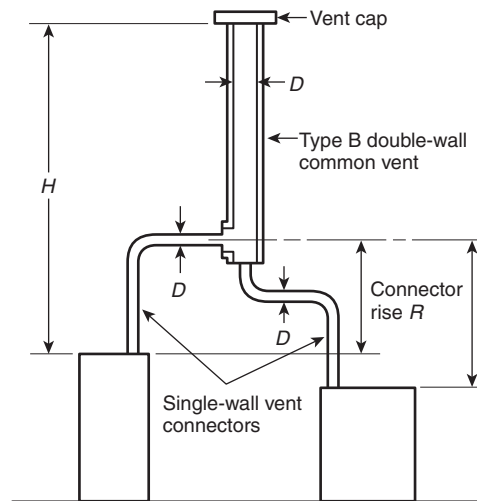

Table 13.2(b) is used when sizing single-wall vent connectors attached to a Type B double-wall common vent.

Note: Each appliance can be either Category I draft hood-equipped or fan-assisted type.

▲ FIGURE F.1(g) Vent System Serving Two or More Appliances with Type B Double-Wall Vent and Single-Wall Metal Vent Connectors.

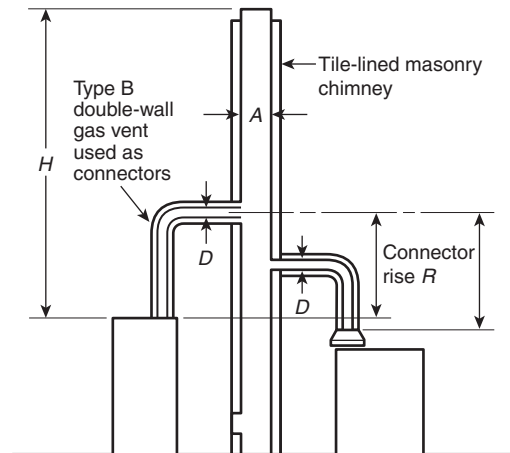

Table 13.2(c) is used when sizing Type B double-wall vent connectors attached to a tile-lined masonry chimney.

Notes:

- (1) A is the equivalent cross-sectional area of the tile liner.
- (2) Each appliance can be either Category I draft hood-equipped or fan-assisted type.

▲ FIGURE F.1(h) Masonry Chimney Serving Two or More Appliances with Type B Double-Wall Vent Connectors.

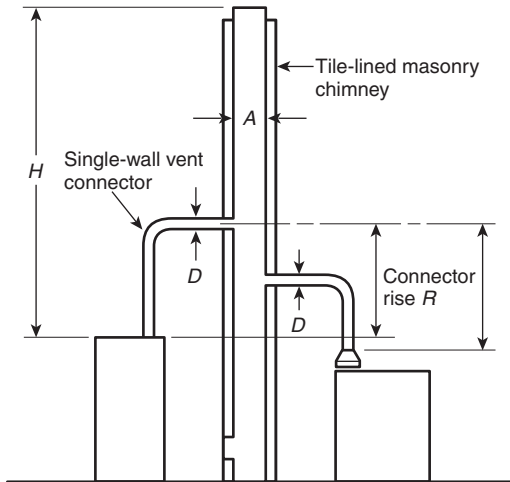
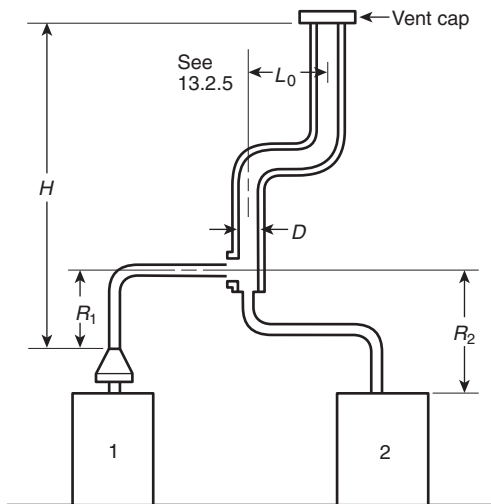

Table 13.2(d) is used when sizing single-wall metal vent connectors attached to a tile-lined masonry chimney.

Notes:

- (1) A is the equivalent cross-sectional area of the tile liner.
- (2) Each appliance can be either Category I draft hood-equipped or fan-assisted type.

▲ FIGURE F.1(i) Masonry Chimney Serving Two or More Appliances with Single-Wall Metal Vent Connectors.



Asbestos cement Type B or single-wall metal pipe vent serving two or more draft hood-equipped appliances. [See Table 13.2(e).]

▲ FIGURE F.1(j) Asbestos Cement Type B or Single-Wall Metal Vent System Serving Two or More Draft Hood-Equipped Appliances.

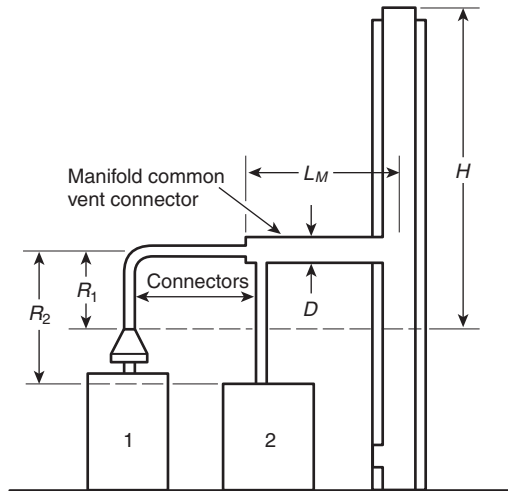

Example: Manifolded common vent connector L_M can be no greater than 18 times the common vent connector manifold inside diameter; that is, a 4 in. (100 mm) inside diameter common vent connector manifold should not exceed 72 in. (1800 mm) in length. (See 13.2.4.)

Note: This is an illustration of a typical manifolded vent connector. Different appliance, vent connector, or common vent types are possible. (See Section 13.2.)

FIGURE F.1(k) Use of Manifolded Common Vent Connector.

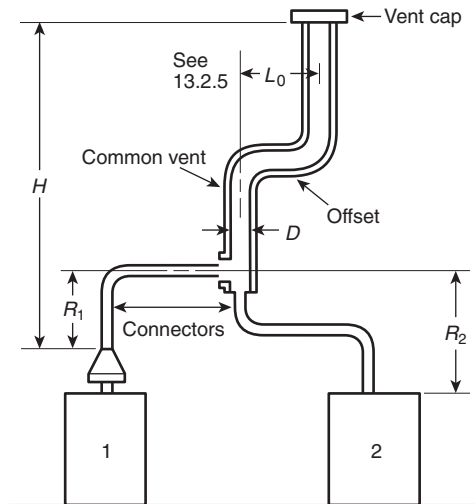

Example: Offset common vent.

Note: This is an illustration of a typical offset vent. Different appliance, vent connector, or vent types are possible. (See Sections 13.1 and 13.2.)

FIGURE F.1(l) Use of Offset Common Vent.

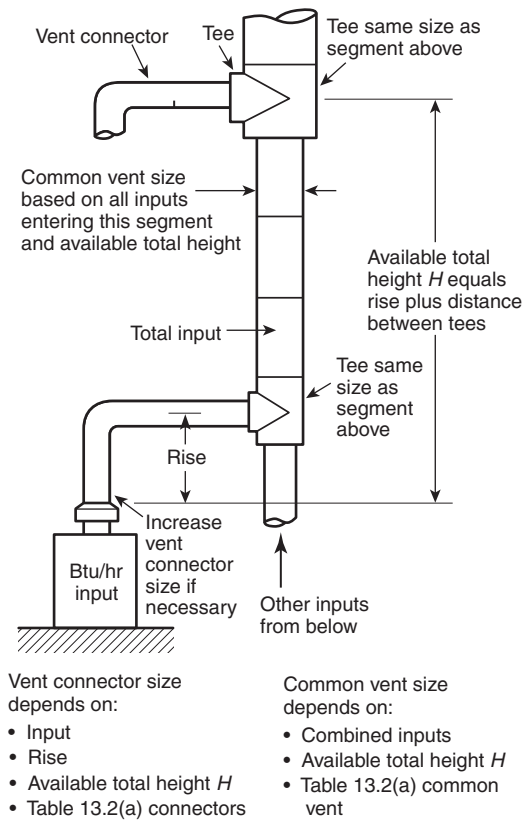

FIGURE F.1(m) Multistory Gas Vent Design Procedure for Each Segment of System.

Solution

Table 13.1(b) should be used to solve this problem, because single-wall metal vent connectors are being used with a Type B vent, as follows:

- (1) Read down the first column in Table 13.1(b) until the row associated with a 10 ft height and 5 ft lateral is found. Read across this row until a vent capacity greater than 120,000 Btu/hr is located in the shaded columns labeled NAT Max for draft hood-equipped appliances. In this case, a 5 in. diameter vent has a capacity of 122,000 Btu/hr and can be used for this application.
- (2) If three 90 degree elbows are used in the vent system, the maximum vent capacity listed in the tables must be reduced by 10 percent. This implies that the 5 in. diameter vent has an adjusted capacity of only 110,000 Btu/hr. In this case, the vent system must be increased to 6 in. in diameter. See the following calculations:

N

[F.1.1a]

$$122,000 \times 0.90 = 110,000 \text{ for 5 in. vent}$$

From Table 13.1(b), select 6 in. vent.

N

[F.1.1b]

$$186,000 \times 0.90 = 167,000$$

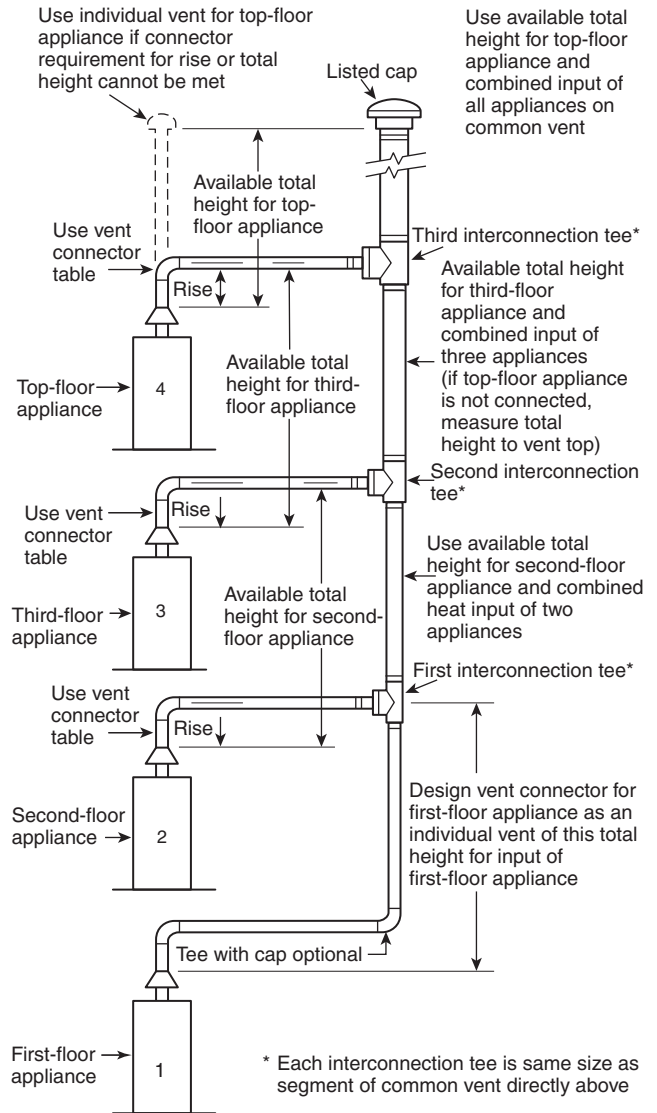

FIGURE F.1(n) Principles of Design of Multistory Vents Using Vent Connector and Common Vent Design Tables. (See 13.2.14 through 13.2.17.)

This figure is greater than the required 120,000. Therefore, use a 6 in. vent and connector where three elbows are used.

F.1.2 Example 2: Single Fan-Assisted Appliance. An installer has an 80,000 Btu/hr input fan-assisted appliance that must be installed using 10 ft of lateral connector attached to a 30 ft high Type B vent. Two 90-degree elbows are needed for the installation. Can a single-wall metal vent connector be used for this application? See Figure F.1.2.

Solution

Table 13.1(b) refers to the use of single-wall metal vent connectors with Type B vent. In the first column find the row associated with a 30 ft height and a 10 ft lateral. Read across this row, looking at the FAN Min and FAN Max columns, to find that a 3 in. diameter single-wall metal vent connector is

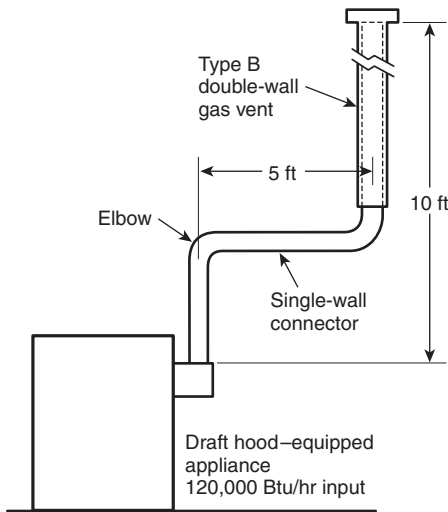

For SI units, 1 ft = 0.305 m.

FIGURE F.1.1 Single Draft Hood–Equipped Appliance— Example 1.

not recommended. Moving to the next larger size single-wall connector (4 in.), we find that a 4 in. diameter single-wall metal connector has a recommended minimum vent capacity of 91,000 Btu/hr and a recommended maximum vent capacity of 144,000 Btu/hr. The 80,000 Btu/hr fan-assisted appliance is outside this range, so the conclusion is that a single-wall metal vent connector cannot be used to vent this appliance using 10 ft of lateral for the connector.

However, if the 80,000 Btu/hr input appliance could be moved to within 5 ft of the vertical vent, a 4 in. single-wall metal connector could be used to vent the appliance. Table 13.1(b) shows the acceptable range of vent capacities for a 4 in. vent with 5 ft of lateral to be between 72,000 Btu/hr and 157,000 Btu/hr.

If the appliance cannot be moved closer to the vertical vent, a Type B vent could be used as the connector material. In this case, Table 13.1(a) shows that, for a 30 ft high vent with 10 ft of lateral, the acceptable range of vent capacities for a 4 in. diameter vent attached to a fan-assisted appliance is between 37,000 Btu/hr and 150,000 Btu/hr.

F.1.3 Example 3: Interpolating Between Table Values. An installer has an 80,000 Btu/hr input appliance with a 4 in. diameter draft hood outlet that needs to be vented into a 12 ft high Type B vent. The vent connector has a 5 ft lateral length and is also Type B. Can this appliance be vented using a 4 in. diameter vent?

Solution

Table 13.1(a) is used in the case of an all Type B vent system. However, Table 13.1(a) does not have an entry for a height of 12 ft, and interpolation must be used. Read down the 4 in. diameter NAT Max column to the row associated with 10 ft height and 5 ft lateral to find the capacity value of 77,000 Btu/hr. Read further down to the 15 ft height, 5 ft lateral row to find the capacity value of 87,000 Btu/hr. The difference between the 15 ft height capacity value and the 10 ft height capacity value is 10,000 Btu/hr. The capacity for a vent system with a 12 ft height is equal to the capacity for a 10 ft

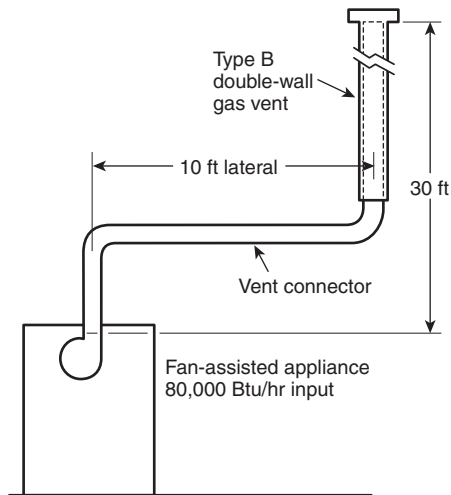

For SI units, 1 ft = 0.305 m.

FIGURE F.1.2 Single Fan-Assisted Appliance — Example 2.

height plus $\frac{2}{5}$ of the difference between the 10 ft and 15 ft height values, or $77,000 + \frac{2}{5} \times 10,000 = 81,000$ Btu/hr. Therefore, a 4 in. diameter vent can be used in the installation.

F.2 Examples Using Common Venting Tables.

F.2.1 Example 4: Common Venting Two Draft Hood–Equipped Appliances. A 35,000-Btu/hr water heater is to be common vented with a 150,000 Btu/hr furnace, using a common vent with a total height of 30 ft. The connector rise is 2 ft for the water heater with a horizontal length of 4 ft. The connector rise for the furnace is 3 ft with a horizontal length of 8 ft. Assume single-wall metal connectors will be used with Type B vent. What size connectors and combined vent should be used in this installation? See Figure F.2.1.

Solution

Table 13.2(b) should be used to size single-wall metal vent connectors attached to Type B vertical vents. In the vent connector capacity portion of Table 13.2(b), find the row associated with a 30 ft vent height. For a 2 ft rise on the vent connector for the water heater, read the shaded columns for draft hood–equipped appliances to find that a 3 in. diameter vent connector has a capacity of 37,000 Btu/hr. Therefore, a 3 in. single-wall metal vent connector can be used with the water heater. For a draft hood–equipped furnace with a 3 ft rise, read across the appropriate row to find that a 5 in. diameter vent connector has a maximum capacity of 120,000 Btu/hr (which is too small for the furnace) and a 6 in. diameter vent connector has a maximum vent capacity of 172,000 Btu/hr. Therefore, a 6 in. diameter vent connector should be used with the 150,000 Btu/hr furnace. Because both vent connector horizontal lengths are less than the maximum lengths listed in 13.2.2, the table values can be used without adjustments.

In the common vent capacity portion of Table 13.2(b), find the row associated with a 30 ft vent height and read over to the NAT + NAT portion of the 6 in. diameter column to find a maximum combined capacity of 257,000 Btu/hr. Since the two appliances total only 185,000 Btu/hr, a 6 in. common vent can be used.

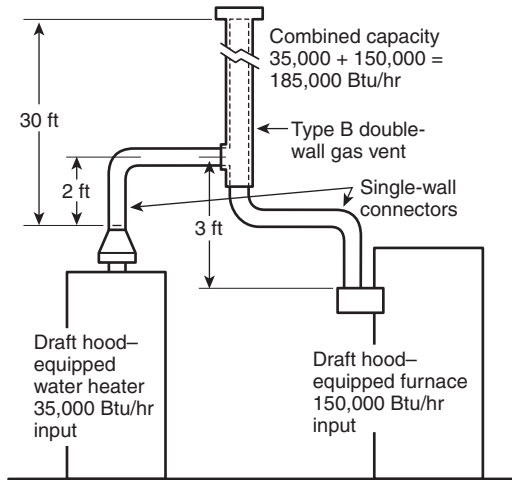

For SI units, 1000 Btu/hr = 0.293 kW, 1 ft = 0.305 m.

FIGURE F.2.1 Common Venting Two Draft Hood–Equipped Appliances — Example 4.

▲ F.2.2 Example 5(a): Common Venting a Draft Hood–Equipped Water Heater with a Fan-Assisted Furnace into a Type B Vent.

In this case, a 35,000 Btu/hr input draft hood–equipped water heater with a 4 in. diameter draft hood outlet, 2 ft of connector rise, and 4 ft of horizontal length is to be common vented with a 100,000 Btu/hr fan-assisted furnace with a 4 in. diameter flue collar, 3 ft of connector rise, and 6 ft of horizontal length. The common vent consists of a 30 ft height of Type B vent. What are the recommended vent diameters for each connector and the common vent? The installer would like to use a single-wall metal vent connector. See Figure F.2.2.

Solution

Water Heater Vent Connector Diameter. Since the water heater vent connector horizontal length of 4 ft is less than the maximum value listed in Table 13.2(b), the venting table values can be used without adjustments. Using the Vent Connector Capacity portion of Table 13.2(b), read down the Total Vent Height (H) column to 30 ft and read across the 2 ft Connector Rise (R) row to the first Btu/hr rating in the NAT Max column that is equal to or greater than the water heater input rating. The table shows that a 3 in. vent connector has a maximum input rating of 37,000 Btu/hr. Although this rating is greater than the water heater input rating, a 3 in. vent connector is prohibited by 13.2.19. A 4 in. vent connector has a maximum input rating of 67,000 Btu/hr and is equal to the draft hood outlet diameter. A 4 in. vent connector is selected. Since the water heater is equipped with a draft hood, there are no minimum input rating restrictions.

Furnace Vent Connector Diameter. Using the Vent Connector Capacity portion of Table 13.2(b), read down the Total Vent Height (H) column to 30 ft and across the 3 ft Connector Rise (R) row. Because the furnace has a fan-assisted combustion system, find the first FAN Max column with a Btu/hr rating greater than the furnace input rating. The 4 in. vent connector has a maximum input rating of 119,000 Btu/hr and a minimum input rating of 85,000 Btu/hr.

The 100,000 Btu/hr furnace in this example falls within this range, so a 4 in. connector is adequate. Because the furnace

vent connector horizontal length of 6 ft is less than the maximum value listed in 13.2.2, the venting table values can be used without adjustment. If the furnace had an input rating of 80,000 Btu/hr, a Type B vent connector would be needed in order to meet the minimum capacity limit.

Common Vent Diameter. The total input to the common vent is 135,000 Btu/hr. Using the Common Vent Capacity portion of Table 13.2(b), read down the Total Vent Height (H) column to 30 ft and across this row to find the smallest vent diameter in the FAN + NAT column that has a Btu/hr rating equal to or greater than 135,000 Btu/hr. The 4 in. common vent has a capacity of 132,000 Btu/hr, and the 5 in. common vent has a capacity of 202,000 Btu/hr. Therefore, the 5 in. common vent should be used in this example.

Summary. In this example, the installer can use a 4 in. diameter, single-wall metal vent connector for the water heater and a 4 in. diameter, single-wall metal vent connector for the furnace. The common vent should be a 5 in. diameter Type B vent.

F.2.3 Example 5(b): Common Venting into an Interior Masonry Chimney.

In this case, the water heater and fan-assisted furnace of Example 5(a) are to be common-vented into a clay-tile-lined masonry chimney with a 30 ft height. The chimney is not exposed to the outdoors below the roof line. The internal dimensions of the clay tile liner are nominally 8 in. \times 12 in. Assuming the same vent connector heights, laterals, and materials found in Example 5(a), what are the recommended vent connector diameters, and is this an acceptable installation?

Solution

Table 13.2(d) is used to size common venting installations involving single-wall connectors into masonry chimneys.

Water Heater Vent Connector Diameter. Using Table 13.2(d), Vent Connector Capacity, read down the Total Vent Height (H) column to 30 ft, and read across the 2 ft Connector Rise (R) row to the first Btu/hr rating in the NAT Max column that is equal to or greater than the water heater input rating. The table shows that a 3 in. vent connector has a maximum input of only 31,000 Btu/hr, while a 4 in. vent connector has a maxi-

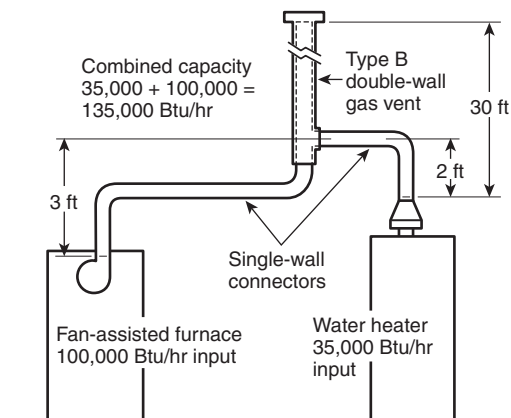

For SI units, 1000 Btu/hr = 0.293 kW, 1 ft = 0.305 m.

FIGURE F.2.2 Common Venting a Draft Hood–Equipped Water Heater with a Fan-Assisted Furnace into a Type B Double-Wall Common Vent — Example 5(a).

imum input of 57,000 Btu/hr. A 4 in. vent connector must therefore be used.

Furnace Vent Connector Diameter. Using the Vent Connector Capacity portion of Table 13.2(d), read down the Total Vent Height (H) column to 30 ft and across the 3 ft Connector Rise (R) row. Because the furnace has a fan-assisted combustion system, find the first FAN Max column with a Btu/hr rating greater than the furnace input rating. The 4 in. vent connector has a maximum input rating of 127,000 Btu/hr and a minimum input rating of 95,000 Btu/hr. The 100,000 Btu/hr furnace in this example falls within this range, so a 4 in. connector is adequate.

Masonry Chimney. From Table F.2.3, the Equivalent Area for a Nominal Liner size of 8 in. \times 12 in. is 63.6 in.². Using Table 13.2(d), Common Vent Capacity, read down the FAN + NAT column under the Minimum Internal Area of Chimney value of 63 to the row for 30 ft height to find a capacity value of 739,000 Btu/hr. The combined input rating of the furnace and water heater, 135,000 Btu/hr, is less than the table value, so this is an acceptable installation.

Subsection 13.2.18 requires the common vent area to be no greater than seven times the smallest listed appliance categorized vent area, flue collar area, or draft hood outlet area. Both appliances in this installation have 4 in. diameter outlets. From Table F.2.3, the equivalent area for an inside diameter of 4 in. is 12.2 in.². Seven times 12.2 equals 85.4, which is greater than 63.6, so this configuration is acceptable.

F.2.4 Example 5(c): Common Venting into an Exterior Masonry Chimney. In this case, the water heater and fan-assisted furnace of Examples 5(a) and 5(b) are to be common-vented into an exterior masonry chimney. The chimney height, clay-tile-liner dimensions, and vent connector heights and laterals are the same as in Example 5(b). This system is being installed in Charlotte, North Carolina. Does this exterior masonry chimney need to be relined? If so, what corrugated metallic liner size is recommended? What vent connector diameters are recommended? See Table F.2.3 and Figure F.2.4.

Solution

According to 13.2.22, Type B vent connectors are required to be used with exterior masonry chimneys. Use Table 13.2(h) and Table 13.2(i) to size FAN+NAT common venting installations involving Type B double-wall connectors into exterior masonry chimneys.

The local 99 percent winter design temperature needed to use Table 13.2(h) and Table 13.2(i) can be found in *ASHRAE Handbook — Fundamentals*. For Charlotte, North Carolina, this design temperature is 19°F.

Chimney Liner Requirement. As in Example 5(b), use the 63 in.² Internal Area columns for this size clay tile liner. Read down the 63 in.² column of Table 13.2(h) to the 30 ft height row to find that the Combined Appliance Maximum Input is 747,000 Btu/hr. The combined input rating of the appliances in this installation, 135,000 Btu/hr, is less than the maximum value, so this criterion is satisfied. Table 13.2(i), at a 19°F Design Temperature, and at the same Vent Height and Internal Area used earlier, shows that the minimum allowable input rating of a space-heating appliance is 470,000 Btu/hr. The furnace input rating of 100,000 Btu/hr is less than this minimum value. So this criterion is not satisfied, and an alternative venting design needs to be used, such as a Type B vent shown

Table F.2.3 Masonry Chimney Liner Dimensions with Circular Equivalents

| Nominal Liner Size (in.) | Inside Dimensions of Liner (in.) | Inside Diameter or Equivalent Diameter (in.) | Equivalent Area (in. ²) |
|--------------------------|--------------------------------------|----------------------------------------------|-------------------------------------|
| 4 \times 8 | $2\frac{1}{2} \times 6\frac{1}{2}$ | 4.0 | 12.2 |
| | | 5.0 | 19.6 |
| | | 6.0 | 28.3 |
| | | 7.0 | 38.3 |
| 8 \times 8 | $6\frac{3}{4} \times 6\frac{3}{4}$ | 7.4 | 42.7 |
| | | 8.0 | 50.3 |
| 8 \times 12 | $6\frac{1}{2} \times 10\frac{1}{2}$ | 9.0 | 63.6 |
| 12 \times 12 | $9\frac{3}{4} \times 9\frac{3}{4}$ | 10.0 | 78.5 |
| | | 10.4 | 83.3 |
| 12 \times 16 | $9\frac{1}{2} \times 13\frac{1}{2}$ | 11.0 | 95.0 |
| | | 11.8 | 107.5 |
| 16 \times 16 | $13\frac{1}{4} \times 13\frac{1}{4}$ | 12.0 | 113.0 |
| | | 14.0 | 153.9 |
| | | 14.5 | 162.9 |
| | | 15.0 | 176.7 |
| 16 \times 20 | 13 \times 17 | 16.2 | 206.1 |
| 20 \times 20 | $16\frac{1}{2} \times 16\frac{3}{4}$ | 18.0 | 254.4 |
| | | 18.2 | 260.2 |
| 20 \times 24 | $16\frac{1}{2} \times 20\frac{1}{2}$ | 20.0 | 314.1 |
| | | 20.1 | 314.2 |
| 24 \times 24 | $20\frac{1}{4} \times 20\frac{1}{4}$ | 22.0 | 380.1 |
| | | 22.1 | 380.1 |
| 24 \times 28 | $20\frac{1}{4} \times 24\frac{1}{4}$ | 24.0 | 452.3 |
| | | 24.1 | 456.2 |
| 28 \times 28 | $24\frac{1}{4} \times 24\frac{1}{4}$ | 26.4 | 543.3 |
| | | 27.0 | 572.5 |
| 30 \times 30 | $25\frac{1}{2} \times 25\frac{1}{2}$ | 27.9 | 607.0 |
| | | 30.0 | 706.8 |
| 30 \times 36 | $25\frac{1}{2} \times 31\frac{1}{2}$ | 30.9 | 749.9 |
| | | 33.0 | 855.3 |
| 36 \times 36 | $31\frac{1}{2} \times 31\frac{1}{2}$ | 34.4 | 929.4 |
| | | 36.0 | 1017.9 |

For SI units, 1 in. = 25.4 mm, 1 in.² = 645 mm².

Note: When liner sizes differ dimensionally from those shown in this table, equivalent diameters can be determined from published tables for square and rectangular ducts of equivalent carrying capacity or by other engineering methods.

in Example 5(a) or a listed chimney liner system shown in the remainder of the example.

According to 13.2.20, Table 13.2(a) or Table 13.2(b) is used for sizing corrugated metallic liners in masonry chimneys, with the maximum common vent capacities reduced by 20 percent. This example will be continued assuming Type B vent connectors.

Water Heater Vent Connector Diameter. Using Table 13.2(a), Vent Connector Capacity, read down the Total Vent Height (H) column to 30 ft, and read across the 2 ft Connector Rise (R) row to the first Btu/hour rating in the NAT Max column that is equal to or greater than the water heater input rating. The table shows that a 3 in. vent connector has a maximum capacity of 39,000 Btu/hr. Although this rating is greater than the water



99% Winter Design Temperatures for the Contiguous United States

This map is a necessarily generalized guide to temperatures in the contiguous United States. Temperatures shown for areas such as mountainous regions and large urban centers are not necessarily accurate. The climate data used to develop this map are from the *ASHRAE Handbook—Fundamentals* (Climate Conditions for the United States).

For 99% winter design temperatures in Alaska, consult the *ASHRAE Handbook—Fundamentals*.

99% winter design temperatures for Hawaii are greater than 37°F.

▲ FIGURE F.2.4 Range of Winter Design Temperatures Used in Analyzing Exterior Masonry Chimneys in the United States.

heater input rating, a 3 in. vent connector is prohibited by 13.2.22. A 4 in. vent connector has a maximum input rating of 70,000 Btu/hr and is equal to the draft hood outlet diameter. A 4 in. vent connector is selected.

Furnace Vent Connector Diameter. Using Table 13.2(a), Vent Connector Capacity, read down the Total Vent Height (H) column to 30 ft, and read across the 3 ft Connector Rise (R) row to the first Btu/hr rating in the FAN Max column that is equal to or greater than the furnace input rating. The 100,000 Btu/hr furnace in this example falls within this range, so a 4 in. connector is adequate.

Chimney Liner Diameter. The total input to the common vent is 135,000 Btu/hr. Using the Common Vent Capacity portion of Table 13.2(a), read down the Total Vent Height (H) column to 30 ft and across this row to find the smallest vent diameter in the FAN+NAT column that has a Btu/hr rating greater than 135,000 Btu/hr. The 4 in. common vent has a capacity of 138,000 Btu/hr. Reducing the maximum capacity by 20 percent results in a maximum capacity for a 4 in. corrugated liner of 110,000 Btu/hr, less than the total input of 135,000 Btu/hr. So a larger liner is needed. The 5 in. common vent capacity listed in Table 13.2(a) is 210,000 Btu/hr, and after reducing by

20 percent is 168,000 Btu/hr. Therefore, a 5 in. corrugated metal liner should be used in this example.

Single-Wall Connectors. Once it has been established that relining the chimney is necessary, Type B double-wall vent connectors are not specifically required. This example could be redone using Table 13.2(b) for single-wall vent connectors. For this case, the vent connector and liner diameters would be the same as found for Type B double-wall connectors.

Annex G Recommended Procedure for Safety Inspection of an Existing Appliance Installation

This annex is not a part of the requirements of this NFPA document but is included for informational purposes only.

For SI units, 1 Btu/hr = 0.293 W.

G.1 General. The following procedure is intended as a guide to aid in determining that an appliance is properly installed and is in a safe condition for continued use. Where a gas supplier performs an inspection, their written procedures should be followed.

G.1.1 Application. This procedure is intended for existing residential installations of a furnace, boiler, room heater, water heater, cooking appliance, fireplace appliance, and clothes dryer. This procedure should be performed prior to any attempt to modify the appliance installation or building envelope.

G.1.2 Weatherization Programs. Before a building envelope is to be modified as part of a weatherization program, the existing appliance installation should be inspected in accordance with these procedures. After all unsafe conditions are repaired, and immediately after the weatherization is complete, the appliance inspections in G.5.2 are to be repeated.

G.1.3 Inspection Procedure. The safety of the building occupant and inspector are to be determined as the first step as described in G.2. Only after the ambient environment is found to be safe should inspections of gas piping and appliances be undertaken. It is recommended that all inspections described in G.3, G.4, and G.6, where the appliance is in the off mode, be completed and any unsafe conditions repaired or corrected before continuing with inspections of an operating appliance described in G.5 and G.6.

G.1.4 Manufacturer Instructions. Where available, the manufacturer's installation and operating instructions for the installed appliance should be used as part of these inspection procedures to determine if the appliance is installed correctly and is operating properly.

G.1.5 Instruments. The inspection procedures include measuring for fuel gas and carbon monoxide (CO) and will require the use of a combustible gas detector (CGD) and a CO detector. It is recommended that both types of detectors be listed. Prior to any inspection, the detectors should be calibrated or tested in accordance with the manufacturer's instructions. In addition, it is recommended that the detectors have the following minimum specifications:

- (1) Gas Detector: The CGD should be capable of indicating the presence of the type of fuel gas for which it is to be used (e.g. natural gas or propane). The combustible gas detector should be capable of the following:
 - (a) *PPM*: Numeric display with a parts per million (ppm) scale from 1 ppm to 900 ppm in 1 ppm increments
 - (b) *LEL*: Numeric display with a percent lower explosive limit (% LEL) scale from 0 percent to 100 percent in 1 percent increments
 - (c) *Audio*: An audio sound feature to locate leaks
- (2) CO Detector: The CO detector should be capable of the following functions and have a numeric display scale as follows:
 - (a) *PPM*: For measuring ambient room and appliance emissions a display scale in parts per million (ppm) from 0 to 1,000 ppm in 1 ppm increments
 - (b) *Alarm*: A sound alarm function where hazardous levels of ambient CO is found (*see G.2 for alarm levels*)
 - (c) *Air Free*: Capable of converting CO measurements to an air-free level in ppm. Where a CO detector is used without an air-free conversion function, the CO air free can be calculated in accordance with Footnote 3 in Table G.6.

G.2 Occupant and Inspector Safety. Prior to entering a building, the inspector should have both a combustible gas detector (CGD) and CO detector turned on, calibrated, and operating. Immediately upon entering the building, a sample of the ambient atmosphere should be taken. Based on CGD and CO detector readings, the inspector should take the following actions:

- (1) Where the CO detector indicates a carbon monoxide level of 70 ppm or greater, the inspector should immediately notify the occupant of the need for themselves and any building occupant to evacuate; the inspector shall immediately evacuate and call 911.
- (2) Where the CO detector indicates a reading between 30 ppm and 70 ppm, the inspector should advise the occupant that high CO levels have been found and recommend that all possible sources of CO be turned off immediately and windows and doors be opened. Where it appears that the source of CO is a permanently installed appliance, advise the occupant to shut the appliance off and have the appliance serviced by a qualified servicing agent.
- (3) Where the CO detector indicates CO below 30 ppm, the inspection can continue. (See U.S. Consumer Product Safety Commission, *Responding to Residential Carbon Monoxide Incidents, Guidelines For Fire and Other Emergency Response Personnel*)
- (4) Where the CGD indicates a combustible gas level of 20 percent LEL or greater, the inspector should immediately notify the occupant of the need for themselves and any building occupant to evacuate; the inspector shall immediately evacuate and call 911.
- (5) Where the CGD indicates a combustible gas level below 20 percent LEL, the inspection can continue.

If during the inspection process it is determined a condition exists that could result in unsafe appliance operation, shut off the appliance and advise the owner of the unsafe condition. Where a gas leak is found that may result in an unsafe condition, advise the owner of the unsafe condition and call the gas supplier to turn off the gas supply. The inspector should not continue a safety inspection on an operating appliance, venting system, and piping system until repairs have been made.

G.3 Gas Piping and Connection Inspections.

G.3.1 Leak Checks. Conduct a test for gas leakage using either a noncorrosive leak detection solution or a CGD confirmed with a leak detection solution.

The preferred method for leak checking is by use of gas leak detection solution applied to all joints. This method provides a reliable visual indication of significant leaks.

The use of a CGD in its audio sensing mode can quickly locate suspect leaks but can be overly sensitive indicating insignificant and false leaks. All suspect leaks found through the use of a CGD should be confirmed using a leak detection solution.

Where gas leakage is confirmed, the owner should be notified that repairs must be made. The inspection should include the following components:

- (1) All gas piping fittings located within the appliance space
- (2) Appliance connector fittings
- (3) Appliance gas valve/regulator housing and connections

▲ G.3.2 Appliance Connector. Verify that the appliance connection type is compliant with Section 9.6 of NFPA 54. Inspect flexible appliance connections to determine if they are free of

cracks, corrosion, and signs of damage. Verify that there are no uncoated copper alloy connectors. Where connectors are determined to be unsafe or where an uncoated copper alloy connector is found, the appliance shutoff valve should be placed in the off position and the owner notified that the connector must be replaced.

G.3.3 Piping Support. Inspect piping to determine that it is adequately supported, that there is no undue stress on the piping, and if there are any improperly capped pipe openings.

▲ **G.3.4 Bonding.** Verify that the electrical bonding of gas piping is compliant with Section 7.12 of NFPA 54.

G.4 Inspections to Be Performed with the Appliance Not Operating. The following safety inspection procedures are performed on appliances that are not operating. These inspections are applicable to all appliance installations.

G.4.1 Preparing for Inspection. Shut off all gas and electrical power to the appliances located in the same room being inspected. For gas supply, use the shutoff valve in the supply line or at the manifold serving each appliance. For electrical power, place the circuit breaker in the off position or remove the fuse that serves each appliance. A lock type device or tag should be installed on each gas shutoff valve and at the electrical panel to indicate that the service has been shut off for inspection purposes.

▲ **G.4.2 Vent System Size and Installation.** Verify that the existing venting system size and installation are compliant with Chapters 11 and 12 of NFPA 54. The size and installation of venting systems for other than natural draft and Category I appliances should be in compliance with the manufacturer's installation instructions. Inspect the venting system to determine that it is free of blockage, restriction, leakage, corrosion, and other deficiencies that could cause an unsafe condition. Inspect masonry chimneys to determine if they are lined. Inspect plastic venting system to determine that it is free of sagging and it is sloped in an upward direction to the outdoor vent termination.

▲ **G.4.3 Combustion Air Supply.** Inspect provisions for combustion air as follows:

- (1) *Non-Direct Vent Appliances.* Determine that non-direct vent appliance installations are compliant with the combustion air requirements in Section 9.3 of NFPA 54. Inspect any interior and exterior combustion air openings and any connected combustion air ducts to determine that there is no blockage, restriction, corrosion, or damage. Inspect to determine if horizontal combustion air ducts are sloped upward toward the air supply source.
- (2) *Direct Vent Appliances.* Verify that the combustion air supply ducts and pipes are securely fastened to direct vent appliance and determine that there are no separations, blockage, restriction, corrosion, or other damage. Determine that the combustion air source is located in the outdoors or to areas that freely communicate to the outdoors.
- (3) *Unvented Appliances.* Verify that the total input of all unvented room heaters and gas-fired refrigerators installed in the same room or rooms that freely communicate with each other does not exceed 20 Btu/hr/ft³.

G.4.4 Flooded Appliances. Inspect the appliance for signs that the appliance may have been damaged by flooding. Signs of flooding include a visible water submerge line on the appli-

ance housing, excessive surface or component rust, deposited debris on internal components, and mildew-like odor. Inform the owner that any part of the appliance control system and any appliance gas control that has been under water must be replaced. All flood-damaged plumbing, heating, cooling, and electrical appliances should be replaced.

G.4.5 Flammable Vapors. Inspect the room/space where the appliance is installed to determine if the area is free of the storage of gasoline or any flammable products such as oil-based solvents, varnishes or adhesives. Where the appliance is installed where flammable products will be stored or used, such as a garage, verify that the appliances burner is a minimum of 18 in. above the floor unless the appliance is listed as flammable vapor ignition-resistant.

▲ **G.4.6 Clearances to Combustibles.** Inspect the immediate location where the appliance is installed to determine if the area is free of rags, paper, or other combustibles. Verify that the appliance and venting system is compliant with clearances to combustible building components in Section 9.2.2 of NFPA 54.

▲ **G.4.7 Appliance Components.** Inspect internal components by removing access panels or other components for the following:

- (1) Inspect burners and crossovers for blockage and corrosion. The presence of soot, debris, and signs of excessive heating could indicate incomplete combustion due to blockage or improper burner adjustments.
- (2) Metallic and non-metallic hoses for signs of cracks, splitting, corrosion, and loose connections
- (3) Signs of improper or incomplete repairs
- (4) Modifications that override controls and safety systems
- (5) Electrical wiring for loose connections; cracked, missing, or worn electrical insulation; and indications of excessive heat or electrical shorting. Appliances requiring an external electrical supply should be inspected for proper electrical connection in accordance with NFPA 70.

G.4.8 Placing Appliances Back in Operation. Return all inspected appliances and systems to their pre-existing state by reinstalling any removed access panels and components. Turn on the gas supply and electricity to each appliance found in safe condition. Proceed to the operating inspections in G.5 through G.6.

G.5 Inspections to Be Performed with the Appliance Operating. The following safety inspection procedures are to be performed on appliances that are operating where there are no unsafe conditions or where corrective repairs have been completed.

G.5.1 General Appliance Operation.

- (1) *Initial Startup.* Adjust the thermostat or other control device to start the appliance. Verify that the appliance starts up normally and is operating properly.

Determine that the pilot(s), where provided, is burning properly and that the main burner ignition is satisfactory by interrupting and re-establishing the electrical supply to the appliance in any convenient manner. If the appliance is equipped with a continuous pilot(s), test all pilot safety devices to determine whether they are operating properly by extinguishing the pilot(s) when the main burner(s) is off and determining, after 3 minutes, that the main burner gas does not flow upon a call for heat. If the appliance is not provided with a pilot(s), test for

- proper operation of the ignition system in accordance with the appliance manufacturer's lighting and operating instructions.
- (2) *Flame Appearance.* Visually inspect the flame appearance for proper color and appearance. Visually determine that the main burner gas is burning properly (i.e., no floating, lifting, or flashback). Adjust the primary air shutter as required. If the appliance is equipped with high and low flame controlling or flame modulation, check for proper main burner operation at low flame.
 - (3) *Appliance Shutdown.* Adjust the thermostat or other control device to **shut down** the appliance. Verify that the appliance shuts off properly.

Δ G.5.2 Test for Combustion Air and Vent Drafting for Natural Draft and Category I Appliances. Combustion air and vent draft procedures are for natural draft and category I appliances equipped with a draft hood and connected to a natural draft venting system.

- (1) *Preparing for Inspection.* Close all exterior building doors and windows and all interior doors between the space in which the appliance is located and other spaces of the building that can be closed. Turn on any clothes dryer. Turn on any exhaust fans, such as range hoods and bathroom exhausts, so they will operate at maximum speed. Do not operate a summer exhaust fan. Close fireplace dampers and any fireplace doors.
- (2) *Placing the Appliance in Operation.* Place the appliance being inspected in operation. Adjust the thermostat or control so the appliance will operate continuously.
- (3) *Spillage Test.* Verify that all appliances located within the same room are in their standby mode and ready for operation. Follow lighting instructions for each appliance as necessary. Test for spillage at the draft hood relief opening as follows:
 - (a) After 5 minutes of main burner operation, check for spillage using smoke.
 - (b) Immediately after the first check, turn on all other fuel gas burning appliances within the same room so they will operate at their full inputs and repeat the spillage test.
 - (c) Shut down all appliances to their standby mode and wait for 15 minutes.
 - (d) Repeat the spillage test steps (a) through (c) on each appliance being inspected.
- (4) *Additional Spillage Tests:* Determine if the appliance venting is impacted by other door and air handler settings by performing the following tests.
 - (a) Set initial test condition in accordance with G.5.2(1).
 - (b) Place the appliance(s) being inspected in operation. Adjust the thermostat or control so the appliance(s) will operate continuously.
 - (c) Open the door between the space in which the appliance(s) is located and the rest of the building. After 5 minutes of main burner operation, check for spillage at each appliance using smoke.
 - (d) Turn on any other central heating or cooling air handler fan that is located outside of the area where the appliances are being inspected. After 5 minutes of main burner operation, check for spillage at each appliance using smoke. The test should be conducted with the door between the space in which the

- appliance(s) is located and the rest of the building in the open and in the closed position.
- (5) Return doors, windows, exhaust fans, fireplace dampers, and any other fuel gas burning appliance to their previous conditions of use.
 - (6) If, after completing the spillage test it is believed sufficient combustion air is not available, the owner should be notified that an alternative combustion air source is needed in accordance with Section 9.3 of the National Fuel Gas Code. Where it is believed that the venting system does not provide adequate natural draft, the owner should be notified that alternative vent sizing, design or configuration is needed in accordance with Chapter 11 and 12 of NFPA 54. If spillage occurs, the owner should be notified as to its cause, be instructed as to which position of the door (open or closed) would lessen its impact, and to arrange for corrective action by an HVAC professional.

Δ G.6 Appliance-Specific Inspections. The following appliance-specific inspections are to be performed as part of a complete inspection. These inspections are performed either with the appliance in the off or standby mode (indicated by "OFF") or on an appliance that is operating (indicated by "ON"). The CO measurements are to be taken only after the appliance is determined to be venting properly. The CO detector should be capable of calculating CO emissions in ppm air free.

G.6.1 Forced Air Furnaces.

- (1) *OFF.* Verify that an air filter is installed and that it is not excessively blocked with dust.
- (2) *OFF.* Inspect visible portions of the furnace combustion chamber for cracks, ruptures, holes, and corrosion. A heat exchanger leakage test should be conducted.
- (3) *ON.* Verify that both the limit and fan controls are operating properly. Limit control operation can be checked by blocking the circulating air inlet or temporarily disconnecting the electrical supply to the blower motor and determining that the limit control acts to shut off the main burner gas.
- (4) *ON.* Verify that the blower compartment door is installed properly and can be resecured properly if opened. Verify that the blower compartment door safety switch operates properly.
- (5) *ON.* Check for flame disturbance before and after blower comes on, which can indicate heat exchanger leaks.
- (6) *ON.* Measure the CO in the vent after 5 minutes of main burner operation. The CO should not exceed threshold in Table G.6.

G.6.2 Boilers.

- (1) *OFF and ON.* Inspect for evidence of water leaks around boiler and connected piping.
- (2) *ON.* Verify that the water pumps are in operating condition. Test low water cutoffs, automatic feed controls, pressure and temperature limit controls, and relief valves in accordance with the manufacturer's recommendations to determine that they are in operating condition.
- (3) *ON.* Measure the CO in the vent after 5 minutes of main burner operation. The CO should not exceed threshold in Table G.6.

Table G.6 CO Thresholds

| Appliance | Threshold Limit |
|-----------------------------------------------|----------------------------------------------|
| Central furnace (all categories) | 400 ppm ^a air free ^{b,c} |
| Floor furnace | 400 ppm air free |
| Gravity furnace | 400 ppm air free |
| Wall furnace | 200 ppm air free |
| Wall furnace (direct vent) | 400 ppm air free |
| Vented room heater | 200 ppm air free |
| Vent-free room heater | 200 ppm air free |
| Boilers (all categories) | 400 ppm air free |
| Water heater | 200 ppm air free |
| Oven /Broiler | 225 ppm as measured |
| Top burner | 25 ppm as measured (per burner) |
| Clothes dryer | 400 ppm air free |
| Refrigerator | 25 ppm as measured |
| Gas log (gas fireplace) | 25 ppm as measured in vent |
| Gas log (installed in wood-burning fireplace) | 400 ppm air free in firebox |

Notes:

^aParts per million

^bAir-free emission levels are based on a mathematical equation (involving carbon monoxide and oxygen or carbon dioxide readings) to convert an actual diluted flue gas carbon monoxide testing sample to an undiluted air-free flue gas carbon monoxide level utilized in the appliance certification standards. For natural gas or propane, using as-measured CO ppm and O₂ percentage:

N**[G.6a]**

$$CO_{Air\ ppm} = \left(\frac{20.9}{20.9 - O_2} \right) \times CO_{ppm}$$

where:

CO_{Air ppm} = Carbon monoxide, air-free ppmCO_{ppm} = As-measured combustion gas carbon monoxideO₂ = Percentage of oxygen in combustion gas, as a percentage

^cAn alternate method of calculating the CO air-free when access to an oxygen meter is not available:

N**[G.6b]**

$$CO_{(air-free)} = \frac{UCO_2}{CO_2} (CO)$$

where:

UCO₂ = Ultimate concentration of carbon dioxide for the fuel being burned in percent for natural gas (12.2 percent) and propane (14.0 percent);

CO₂ = Measured concentration of carbon dioxide in combustion products in percent; and

CO = Measured concentration of carbon monoxide in combustion products in percent.

G.6.3 Water Heaters.

- (1) *OFF.* Verify that the pressure-temperature relief valve is in operating condition. Water in the heater should be at operating temperature.
- (2) *OFF.* Verify that inspection covers, glass, and gaskets are intact and in place on a flammable vapor ignition resistant (FVIR)-type water heater.
- (3) *ON.* Verify that the thermostat is set in accordance with the manufacturer's operating instructions and measure the water temperature at the closest tub or sink to verify that it is no greater than 120°F.
- (4) *OFF.* Where required by the local building code in earthquake-prone locations, inspect that the water heater is secured to the wall studs in two locations (high and low) using appropriate metal strapping and bolts.
- (5) *ON.* Measure the CO in the vent after 5 minutes of main burner operation. The CO should not exceed threshold in Table G.6.

G.6.4 Cooking Appliances.

- (1) *OFF.* Inspect oven cavity and range-top exhaust vent for blockage with aluminum foil or other materials.
- (2) *OFF.* Inspect cook top to verify that it is free from a build-up of grease.
- (3) *ON.* Measure the CO above each burner and at the oven exhaust vents after 5 minutes of burner operation. The CO should not exceed threshold in Table G.6.

G.6.5 Vented Room Heaters.

- (1) *OFF.* For built-in room heaters and wall furnaces, inspect that the burner compartment is free of lint and debris.
- (2) *OFF.* Inspect that furnishings and combustible building components are not blocking the heater.
- (3) *ON.* Measure the CO in the vent after 5 minutes of main burner operation. The CO should not exceed threshold in Table G.6.

G.6.6 Vent-Free Heaters.

- (1) *OFF.* Verify that the heater input is a maximum of 40,000 Btu/hr input, but not more than 10,000 Btu/hr where installed in a bedroom, and 6,000 Btu/hr where installed in a bathroom.
- (2) *OFF.* Inspect the ceramic logs provided with gas log-type vent-free heaters to verify that they are located and aligned properly.
- (3) *OFF.* Inspect the heater to verify that it is free of excess lint build-up and debris.
- (4) *OFF.* Verify that the oxygen depletion safety shutoff system has not been altered or bypassed.
- (5) *ON.* Verify that the main burner shuts down within 3 minutes by extinguishing the pilot light. The test is meant to simulate the operation of the oxygen depletion system (ODS).
- (6) *ON.* Measure the CO after 5 minutes of main burner operation. The CO should not exceed threshold in Table G.6.

G.6.7 Gas Log Sets and Gas Fireplaces.

- (1) *OFF.* For gas logs installed in wood-burning fireplaces equipped with a damper, verify that the fireplace damper is in a fixed open position.
- (2) *ON.* Measure the CO in the firebox (log sets installed in wood burning fireplaces or in the vent [gas fireplace])

after 5 minutes of main burner operation. The CO should not exceed threshold in Table G.6.

G.6.8 Gas Clothes Dryer.

- (1) *OFF.* Where installed in a closet, verify that a source of make-up air is provided and inspect that any make-up air openings, louvers, and ducts are free of blockage.
- (2) *OFF.* Inspect for excess amounts of lint around the dryer and on dryer components. Verify that the lint trap is installed properly and that it does not have holes or tears. Verify that it is in a clean condition.
- (3) *OFF.* Inspect visible portions of the exhaust duct and connections for loose fittings and connections, blockage, and signs of corrosion. Verify that the duct termination is not blocked and that it terminates in an outdoor location. Verify that only approved metal vent ducting material is installed (plastic and vinyl materials are not approved for gas dryers).
- (4) *ON.* Verify mechanical components, including drum and blower, are operating properly.
- (5) *ON.* Operate the clothes dryer and verify that **exhaust** system is intact and exhaust is exiting the termination.
- (6) *ON.* Measure the CO at the exhaust duct or termination after 5 minutes of main burner operation. The CO should not exceed threshold in Table G.6.

Annex H Indoor Combustion Air Calculation Examples

This annex is not a part of the requirements of this NFPA document but is included for informational purposes only.

For SI units, 1 Btu/hr = 0.293 W, 1 ft³ = 0.028 m³, 1 ft = 0.305 m, 1 in. w.c. = 249 Pa.

H.1 New Installation. Determine if the indoor volume is sufficient to supply combustion air for the following new installation example.

Example Installation 1: A 100,000 Btu/hr fan-assisted furnace and a 40,000 Btu/hr draft hood-equipped water heater are being installed in a basement of a new single-family home. The basement measures 25 ft × 40 ft with an 8 ft ceiling.

Solution

- (1) *Determine the total required volume:* Because the air infiltration rate is unknown, the standard method to determine combustion air is used to calculate the required volume.
 - (a) The combined input for the appliances located in the basement is calculated as follows:
100,000 Btu/hr + 40,000 Btu/hr = 140,000 Btu/hr
 - (b) The Standard Method requires that the required volume be determined based on 50 cubic feet per 1000 Btu/hour.
 - (c) Using Table A.9.3.2.1, the required volume for a 140,000 Btu/hr combined input is 7000 ft³.
- (2) *Determine available volume:* The available volume is the total basement volume:

Available Volume: 25 ft × 40 ft × 8 ft ceiling = 8000 ft³

Conclusion: The installation can use indoor air because the available volume of 8000 ft³ exceeds the total required volume of 7000 ft³. No outdoor air openings are required.

Δ H.2 New Installation, Known Air Infiltration Rate Method. Determine if the indoor volume is sufficient to supply combustion air for the following replacement installation example.

Example Installation 2: A 100,000 Btu/hr fan-assisted furnace and a 40,000 Btu/hr draft hood-equipped water heater are being installed in a new single-family house. It was determined (either by use of the ASHRAE calculation method or blower door test) that the house has 0.65 air changes per hour (ACH). The furnace and water heater are being installed in a 20 ft × 35 ft basement with an 8 ft ceiling height.

Solution

- (1) *Determine the required volume:* Because two types of appliances are located in the space — a fan-assisted furnace and a draft hood-equipped water heater — the required volume must be determined for each appliance and then combined to determine the total required volume:
 - (a) *Fan-assisted furnace:* For structures for which the air infiltration rate is known, the method shown in 9.3.2.2 permits the use of the equation in 9.3.2.2(2) to determine the required volume for a fan-assisted appliance. Paragraph 9.3.2.2(3) limits the use of the equation to air change rates equal to or less than 0.60 ACH. While the house was determined to have a 0.65 ACH, 0.60 is used to calculate the required volume. Using the equation in 9.3.2.2(2), the required volume for a 100,000 Btu/hr fan-assisted furnace is calculated as follows:

[H.2(1)(a)]

$$\begin{aligned} &= \frac{15 \text{ ft}^3}{0.60} \left(\frac{100,000 \text{ Btu/hr}}{1000 \text{ Btu/hr}} \right) \\ &= 2500 \text{ ft}^3 \end{aligned}$$

Paragraph 9.3.2.2 specifies a lower required volume limitation for fan-assisted appliances at no smaller than 25 ft³ per 1000 Btu/hr. From Table A.9.3.2.2(b), the lower limit is 2500 ft³.

Because the calculated required volume of 2308 ft³ falls below the lower required volume limit, the lower limit of 2500 ft³ must be used as the minimum required volume.

- (b) *Draft hood-equipped water heater:* For structures for which the air infiltration rate is known, the method shown in 9.3.2.2 permits the use of the equation in 9.3.2.2(1) to determine the required volume for a draft hood-equipped appliance. Paragraph 9.3.2.2(3) limits the use of the equation to air change rates equal to or less than 0.60 ACH. While the house was determined to have a 0.65 ACH, 0.60 is used to calculate the required volume. Using the equation in 9.3.2.2(1), the required volume for the 40,000 Btu/hr water heater is calculated as follows:

[H.2(1)(b)]

$$\begin{aligned} &= \frac{21 \text{ ft}^3}{0.60} \left(\frac{40,000 \text{ Btu/hr}}{1000 \text{ Btu/hr}} \right) \\ &= 1400 \text{ ft}^3 \end{aligned}$$

Paragraph 9.3.2.2 specifies a lower required volume limitation for appliances other than fan-assisted at no smaller than 35 ft³ per 1000 Btu/hr. From Table A.9.3.2.2(a), the lower limit is 1400 ft³.

Because the calculated required volume of 1292 ft³ falls below the lower required volume limit, the lower limit of 1400 ft³ must be used as the minimum required volume.

- (c) *Total required volume:* Subsection 9.3.2 states that the total required volume of indoor air is the sum of the required volumes for all appliances located in the space:

$$\text{Total Required} = 2500 \text{ ft}^3 + 1400 \text{ ft}^3 = 3900 \text{ ft}^3$$

- (2) *Determine available volume:* The available volume is determined as follows:

[H.2(2)]

$$(20 \text{ ft} \times 35 \text{ ft}) \times 8 \text{ ft} = 5600 \text{ ft}^3$$

Conclusion: The installation can use indoor air because the available volume of 5600 ft³ exceeds the total required volume of 3900 ft³. No outdoor air openings are required.

▲ H.3 New Installation, Known Air Infiltration Rate Method.

Determine if the indoor volume is sufficient to supply combustion air for the following replacement installation example.

Example Installation 3: A 100,000 Btu/hr fan-assisted furnace and a 40,000 Btu/hr draft hood-equipped water heater are being installed in a new single-family house. It was determined (either by use of the ASHRAE calculation method or blower door test) that the house has 0.30 air changes per hour (ACH). The furnace and water heater are being installed in a 20 ft × 35 ft basement with an 8 ft ceiling height.

Solution

- (1) *Determine the required volume:* Because two types of appliances are located in the space — a fan-assisted furnace and a draft hood-equipped water heater — the required volume must be determined for each appliance and then combined to determine the total required volume:

- (a) *Fan-assisted furnace:* For structures for which the air infiltration rate is known, the method shown in 9.3.2.2 permits the use of the equation in 9.3.2.2(2) to determine the required volume for a fan-assisted appliance. Paragraph 9.3.2.3 limits the use of the equation to air change rates equal to or less than 0.60 ACH. Because 0.30 ACH is less than 0.60 ACH, 0.30 can be used to calculate the required volume. Using the equation in 9.3.2.2(2), the required volume for a 100,000 Btu/hr fan-assisted furnace is calculated as follows:

[H.3(1)(a)]

$$\begin{aligned} &= \frac{15 \text{ ft}^3}{0.30} \left(\frac{100,000 \text{ Btu/hr}}{1000 \text{ Btu/hr}} \right) \\ &= 5000 \text{ ft}^3 \end{aligned}$$

Paragraph 9.3.2.2 specifies a lower required volume limitation for fan-assisted appliances at no smaller than 25 ft³ per 1000 Btu/hr. From Table A.9.3.2.2(b), the lower limit is 2500 ft³.

Because the calculated required volume of 5000 ft³ is above the lower required volume limit, use this amount as the minimum required volume.

- (b) *Draft hood-equipped water heater:* For structures for which the air infiltration rate is known, the method shown in 9.3.2.2 permits the use of the equation in 9.3.2.2(1) to determine the required volume for a draft hood-equipped appliance. Paragraph 9.3.2.2(3) limits the use of the equation to air change rates equal to or less than 0.60 ACH. While the house was determined to have a 0.65 ACH, 0.30 ACH is used to calculate the required volume. Using the equation in 9.3.2.2(1), the required volume for the 40,000 Btu/hr water heater is calculated as follows:

[H.3(1)(b)]

$$\begin{aligned} &= \frac{21 \text{ ft}^3}{0.30} \left(\frac{40,000 \text{ Btu/hr}}{1000 \text{ Btu/hr}} \right) \\ &= 2800 \text{ ft}^3 \end{aligned}$$

Paragraph 9.3.2.2 specifies a lower required volume limitation for appliances other than fan-assisted at no smaller than 35 ft³ per 1000 Btu/hr. From Table A.9.3.2.2(a), the lower limit is 1400 ft³.

Because the calculated required volume of 2800 ft³ is above the lower required volume limit, use this amount as the minimum required volume.

- (c) *Total required volume:* Subsection 9.3.2 states that the total required volume to use indoor air is the sum of the required volumes for all appliances located in the space:

$$\text{Total Required} = 5000 \text{ ft}^3 + 2800 \text{ ft}^3 = 7800 \text{ ft}^3$$

- (2) *Determine available volume:* The available volume is determined as follows:

[H.3(2)]

$$(20 \text{ ft} \times 35 \text{ ft}) \times 8 \text{ ft} = 5600 \text{ ft}^3$$

Conclusion: The installation cannot use indoor air alone, because the available volume of 5600 ft³ is less than the total required volume of 7800 ft³. Outdoor air openings can be sized in accordance with all air from the outdoors or by use of the combination of indoor/outdoor air method.

Annex I Example of Combination of Indoor and Outdoor Combustion and Ventilation Opening Design

This annex is not a part of the requirements of this NFPA document but is included for informational purposes only.

For SI units, 1 Btu/hr = 0.293 W, 1 ft³ = 0.028 m³, 1 ft = 0.305 m, 1 in. w.c. = 249 Pa.

- ▲ I.1 **Example of Combination Indoor and Outdoor Combustion Air Opening Design.** Determine the required combination of indoor and outdoor combustion air opening sizes for the following appliance installation example.

Example Installation: A fan-assisted furnace and a draft hood-equipped water heater with the following inputs are located in a 15 ft × 30 ft basement with an 8 ft ceiling. No additional indoor spaces can be used to help meet the appliance combustion air needs.

Fan-Assisted Furnace Input: 100,000 Btu/hr

Draft Hood–Equipped Water Heater Input: 40,000 Btu/hr

Solution

- (1) *Determine the total available room volume:* Appliance room volume: 15 ft × 30 ft with an 8 ft ceiling = 3600 ft³
- (2) *Determine the total required volume:* The Standard Method to determine combustion air is used to calculate the required volume. The combined input for the appliances located in the basement is calculated as follows:

[I.1(2)]

$$100,000 \text{ Btu/hr} + 40,000 \text{ Btu/hr} = 140,000 \text{ Btu/hr}$$

The Standard Method requires that the required volume be determined based on 50 ft³ per 1000 Btu/hr. Using Table A.9.3.2.1, the required volume for a 140,000 Btu/hr water heater is 7000 ft³.

Conclusion: The indoor volume is insufficient to supply combustion air since the total of 3600 ft³ does not meet the required volume of 7000 ft³. Therefore, additional combustion air must be provided from the outdoors.

- (3) Determine the ratio of the available volume to the required volume:

[I.1(3)]

$$\frac{3600 \text{ ft}^3}{7000 \text{ ft}^3} = 0.51$$

- (4) Determine the reduction factor to be used to reduce the full outdoor air opening size to the minimum required based on ratio of indoor spaces:
1.00 - 0.51 (from Step 3) = 0.49
- (5) Determine the single outdoor combustion air opening size as though all combustion air is to come from outdoors. In this example, the combustion air opening directly communicates with the outdoors:

[I.1(5)]

$$\frac{140,000 \text{ Btu/hr}}{3000 \text{ Btu/in.}^2} = 47 \text{ in.}^2$$

- (6) Determine the minimum outdoor combustion air opening area:

Outdoor opening area = 0.49 (from Step 4) × 47 in.² = 23 in.²
Paragraph 9.3.4(3)(c) requires the minimum dimension of the air opening should not be less than 3 in.

Annex J Enforcement

This annex is not a part of the requirements of this NFPA document but is included for informational purposes only.

J.1 The following sample ordinance is provided to assist a jurisdiction in the adoption of this code and is not part of this code.

ORDINANCE NO. _____

An ordinance of the [jurisdiction] adopting the 2012 edition of NFPA 54/ANSI Z223.1, *National Fuel Gas Code*, documents listed in Chapter 2 of that code; prescribing regulations governing conditions hazardous to life and property from fire or

explosion; providing for the issuance of permits and collection of fees; repealing Ordinance No. _____ of the [jurisdiction] and all other ordinances and parts of ordinances in conflict therewith; providing a penalty; providing a severability clause; and providing for publication; and providing an effective date.

BE IT ORDAINED BY THE [governing body] OF THE [jurisdiction]:

SECTION 1 That the *National Fuel Gas Code* and documents adopted by Chapter 2, three (3) copies of which are on file and are open to inspection by the public in the office of the [jurisdiction's keeper of records] of the [jurisdiction], are hereby adopted and incorporated into this ordinance as fully as if set out at length herein, and from the date on which this ordinance shall take effect, the provisions thereof shall be controlling within the limits of the [jurisdiction]. The same are hereby adopted as the code of the [jurisdiction] for the purpose of prescribing regulations governing conditions hazardous to life and property from fire or explosion and providing for issuance of permits and collection of fees.

SECTION 2 Any person who shall violate any provision of this code or standard hereby adopted or fail to comply therewith; or who shall violate or fail to comply with any order made thereunder; or who shall build in violation of any detailed statement of specifications or plans submitted and approved thereunder; or failed to operate in accordance with any certificate or permit issued thereunder; and from which no appeal has been taken; or who shall fail to comply with such an order as affirmed or modified by or by a court of competent jurisdiction, within the time fixed herein, shall severally for each and every such violation and noncompliance, respectively, be guilty of a misdemeanor, punishable by a fine of not less than \$ _____ nor more than \$ _____ or by imprisonment for not less than _____ days nor more than _____ days or by both such fine and imprisonment. The imposition of one penalty for any violation shall not excuse the violation or permit it to continue; and all such persons shall be required to correct or remedy such violations or defects within a reasonable time; and when not otherwise specified the application of the above penalty shall not be held to prevent the enforced removal of prohibited conditions. Each day that prohibited conditions are maintained shall constitute a separate offense.

SECTION 3 Additions, insertions, and changes — that the 2012 edition of NFPA 54/ANSI Z223.1, *National Fuel Gas Code*, is amended and changed in the following respects:

List Amendments

SECTION 4 That ordinance No. _____ of [jurisdiction] entitled [fill in the title of the ordinance or ordinances in effect at the present time] and all other ordinances or parts of ordinances in conflict herewith are hereby repealed.

SECTION 5 That if any section, subsection, sentence, clause, or phrase of this ordinance is, for any reason, held to be invalid or unconstitutional, such decision shall not affect the validity or constitutionality of the remaining portions of this ordinance. The [governing body] hereby declares that it would have passed this ordinance, and each section, subsection, clause, or phrase hereof, irrespective of the fact that any one or more sections, subsections, sentences, clauses, and phrases be declared unconstitutional.

SECTION 6 That the [jurisdiction's keeper of records] is hereby ordered and directed to cause this ordinance to be published.

[NOTE: An additional provision may be required to direct the number of times the ordinance is to be published and to specify that it is to be in a newspaper in general circulation. Posting may also be required.]

SECTION 7 That this ordinance and the rules, regulations, provisions, requirements, orders, and matters established and adopted hereby shall take effect and be in full force and effect [time period] from and after the date of its final passage and adoption.

Annex K Informational References

K.1 Referenced Publications. *The documents or portions thereof listed in this annex are referenced within the informational sections of this code and are not part of the requirements of this document unless also listed in Chapter 2 for other reasons.*

K.1.1 NFPA Publications. National Fire Protection Association, 1 Batterymarch Park, Quincy, MA 02169-7471.

NFPA 56, *Standard for Fire and Explosion Prevention During Cleaning and Purging of Flammable Gas Piping Systems*, 2017 edition.

NFPA 58, *Liquefied Petroleum Gas Code*, 2017 edition.

NFPA 68, *Standard on Explosion Protection by Deflagration Venting*, 2013 edition.

NFPA 70®, *National Electrical Code®*, 2017 edition.

NFPA 90A, *Standard for the Installation of Air-Conditioning and Ventilating Systems*, 2018 edition.

NFPA 90B, *Standard for the Installation of Warm Air Heating and Air-Conditioning Systems*, 2018 edition.

NFPA 96, *Standard for Ventilation Control and Fire Protection of Commercial Cooking Operations*, 2017 edition.

NFPA 780, *Standard for the Installation of Lightning Protection Systems*, 2017 edition.

National Fuel Gas Code Handbook, 2018 edition.

K.1.2 Other Publications.

K.1.2.1 API Publications. American Petroleum Institute, 1220 L Street, NW, Washington, DC 20005-4070.

API STD 1104, *Welding Pipelines and Related Facilities*, 2013.

K.1.2.2 ASHRAE Publications. ASHRAE, Inc., 1791 Tullie Circle, N.E., Atlanta, GA 30329-2305, (404) 636-8400, www.ashrae.org.

ASHRAE Handbook — Fundamentals, 2013.

ASHRAE Handbook — HVAC Systems and Equipment, 2012.

K.1.2.3 ASME Publications. American Society of Mechanical Engineers, Two Park Avenue, New York, NY 10016-5990, (800) 843-2763, www.asme.org.

Boiler and Pressure Vessel Code, Section IX and Section IV, 2015.

ANSI/ASME B16.1, *Gray Iron Pipe Flanges and Flanged Fittings: Classes 25, 125, and 250*, 2010.

ANSI/ASME B36.10M, *Welded and Seamless Wrought Steel Pipe*, 2015.

K.1.2.4 ASTM Publications. ASTM International, 100 Barr Harbor Drive, P.O. Box C700, West Conshohocken, PA 19428-2959, (610) 833-9585, www.astm.org.

ASTM A53/A53M, *Standard Specification for Pipe, Steel, Black and Hot-Dipped, Zinc-Coated, Welded and Seamless*, 2012.

ASTM A106/A106M, *Standard Specification for Seamless Carbon Steel Pipe for High-Temperature Service*, 2015.

ASTM A254/A254M, *Standard Specification for Copper-Brazed Steel Tubing*, 2012.

ASTM B88, *Standard Specification for Seamless Copper Water Tube*, 2014.

ASTM B210, *Standard Specification for Aluminum and Aluminum-Alloy Drawn Seamless Tubes*, 2012.

ASTM B241/B241M, *Standard Specification for Aluminum and Aluminum-Alloy Seamless Pipe and Seamless Extruded Tube*, 2016.

ASTM B280, *Standard Specification for Seamless Copper Tube for Air-Conditioning and Refrigeration Field Service*, 2016.

ASTM D2385, *Test Method for Hydrogen Sulfide and Mercaptan Sulfur in Natural Gas (Cadmium Sulfate — Iodometric Titration Method)*, 1981, reaffirmed 1990 (withdrawn 1995).

ASTM D2420, *Method of Test for Hydrogen Sulfide in Liquefied Petroleum (LP) Gases (Lead Acetate Method)*, 2013.

ASTM D2513, *Standard Specification for Polyethylene (PE) Gas Pressure Pipe, Tubing, and Fittings*, 2014.

ASTM F1973, *Standard Specification for Factory Assembled Anodeless Risers and Transition Fittings in Polyethylene (PE) and Polyamide 11 (PA11) and Polyamide 12 (PA12) Fuel Gas Distribution Systems*, 2013.

ASTM F2509, *Standard Specification for Field-Assembled Anodeless Riser Kits for Use on Outside Diameter Controlled Polyethylene Gas Distribution Pipe and Tubing*, 2015.

ASTM F2945, *Standard Specification for Polyamide 11 Gas Pressure Pipe, Tubing, and Fittings*, 2015.

K.1.2.5 AWS Publications. American Welding Society, 8669 NW 36 Street, #130, Miami, FL 33166-6672, (800) 443-9353, www.aws.org.

AWS B2.1/B2.1M, *Specification for Welding Procedure and Performance Qualification*, 2014.

AWS B2.2/B2.2M, *Specification for Brazing Procedure and Performance Qualification*, 2010.

▲ K.1.2.6 CSA Group Publications. CSA Group, 178 Rexdale Boulevard, Toronto, ON M9W 1R3, Canada, (216) 524-4990, www.csagroup.org.

ANSI LC 1/CSA 6.26, *Fuel Gas Piping Systems Using Corrugated Stainless Steel Tubing*, 2014.

ANSI LC 4/CSA 6.32, *Press-Connect Metallic Fittings for Use in Fuel Gas Distribution Systems*, 2012.

ANSI Z21.50/CSA 2.22, *Vented Gas Fireplaces*, 2014.

ANSI Z21.60/CSA 2.26, *Decorative Gas Appliances for Installation in Solid-Fuel Burning Fireplaces*, 2012.

K.1.2.7 NACE Publications. NACE International, 15835 Park Ten Place, Houston, TX 77084-4906, www.nace.org.

NACE SP0169, *Control of External Corrosion on Underground or Submerged Metallic Piping Systems*, 2013.

■ K.1.2.8 UL Publications. Underwriters Laboratories Inc., 333 Pfingsten Road, Northbrook, IL 60062-2096, www.ul.com.

ANSI/UL 651, *Schedule 40 and 80 Rigid PVC Conduit and Fittings*, 2011, reapproved 2014.

K.1.2.9 U.S. Government Publications. U.S. Government Publishing Office, 732 North Capitol Street, NW, Washington, DC 20401-0001.

Responding to Residential Carbon Monoxide Incidents, Guidelines for Fire and Other Emergency Response Personnel, U.S. Consumer Product Safety Commission, July 23, 2002.

K.1.2.10 Other Publications. *Piping Handbook*, 2000, New York: McGraw-Hill Book Company.

Project Number 21323, *Validation of Installation Methods for CSST Gas Piping to Mitigate Indirect Lightning Related Damage*, Gas Technology Institute 2015.

K.2 Informational References. The following documents or portions thereof are listed here as informational resources only. They are not a part of the requirements of this document.

K.2.1 NFPA Publications. National Fire Protection Association, 1 Batterymarch Park, Quincy, MA 02169-7471.

NFPA 30, *Flammable and Combustible Liquids Code*, 2018 edition.

NFPA 59, *Utility LP-Gas Plant Code*, 2018 edition.

NFPA 61, *Standard for the Prevention of Fires and Dust Explosions in Agricultural and Food Processing Facilities*, 2013 edition.

NFPA 86, *Standard for Ovens and Furnaces*, 2015 edition.

NFPA 211, *Standard for Chimneys, Fireplaces, Vents, and Solid Fuel-Burning Appliances*, 2016 edition.

NFPA 501A, *Standard for Fire Safety Criteria for Manufactured Home Installations, Sites, and Communities*, 2013 edition.

▲ K.2.2 CSA Group Publications. CSA Group, 178 Rexdale Boulevard, Toronto, ON M9W 1R3, Canada, (216) 524-4990, www.csagroup.org.

ANSI/AGA NGV 3.1/CSA 12.3, *Fuel System Components for Compressed Natural Gas Powered Vehicles*, 2014.

AGA/CSA NGV 1, *Compressed Natural Gas Vehicle (NGV) Fueling Connection Devices*, 2006 reaffirmed 2012.

ANSI/CSA FC 1, *Fuel Cell Technologies — Part 3-100: Stationary fuel cell power systems — Safety*, 2014.

ANSI/CSA NGV 2, *Natural Gas Vehicle Fuel Containers*, 2007 reaffirmed 2012.

ANSI/LC 2A, *Direct Gas-Fired Circulating Heaters for Agricultural Animal Confinement Buildings*, 1998 reaffirmed 2015.

ANSI/LC 2, *Direct Gas-Fired Circulating Heaters for Agricultural Animal Confinement Buildings*, 1996 reaffirmed 2015.

ANSI Z21.1/CSA 1.1, *Household Cooking Gas Appliances*, 2016.

ANSI Z21.5.1/CSA 7.1, *Gas Clothes Dryers — Volume I — Type 1 Clothes Dryers*, 2015.

ANSI Z21.5.2/CSA 7.2, *Gas Clothes Dryers — Volume II — Type 2 Clothes Dryers*, 2013.

ANSI Z21.10.1/CSA 4.1, *Gas Water Heaters — Volume I — Storage Water Heaters with Input Ratings of 75,000 Btu per Hour or Less*, 2014.

ANSI Z21.10.3/CSA 4.3, *Gas Water Heaters — Volume III — Storage Water Heaters with Input Ratings above 75,000 Btu per Hour, Circulating and Instantaneous*, 2015.

ANSI Z21.11.2, *Gas-Fired Room Heaters — Volume II — Unvented Room Heaters*, 2013.

ANSI Z21.12, *Draft Hoods*, 1990 reaffirmed 2015.

ANSI Z21.13/CSA 4.9, *Gas-Fired Low-Pressure Steam and Hot Water Boilers*, 2014.

ANSI Z21.15/CSA 9.1, *Manually Operated Gas Valves for Appliances, Appliance Connector Valves, and Hose End Valves*, 2009 reaffirmed 2014.

ANSI Z21.17/CSA 2.7, *Domestic Gas Conversion Burners*, 1998 reaffirmed 2014.

ANSI Z21.18/CSA 6.3, *Gas Appliance Pressure Regulators*, 2007 reaffirmed 2012.

ANSI Z21.19/CSA 1.4, *Refrigerators Using Gas Fuel*, 2014.

ANSI Z21.20/CSA C22.2 — No. 60730-2-5, *Automatic Electrical Controls for Household and Similar Use — Part 2: Particular Requirements for Automatic Burner Ignition Systems and Components*, 2014.

ANSI Z21.21/CSA 6.5, *Automatic Valves for Gas Appliances*, 2015.

ANSI Z21.22/CSA 4.4, *Relief Valves for Hot Water Supply Systems*, 2015.

ANSI Z21.23, *Gas Appliance Thermostats*, 2010 reaffirmed 2015.

ANSI Z21.24/CSA 6.10, *Connectors for Gas Appliances*, 2015.

ANSI Z21.35/CSA 6.8, *Pilot Gas Filters*, 2005 reaffirmed 2014.

ANSI Z21.40.1/CSA 2.91, *Gas-Fired, Heat Activated Air-Conditioning and Heat Pump Appliances*, 1996 reaffirmed 2012.

ANSI Z21.40.2/CSA 2.92, *Gas-Fired, Work Activated Air-Conditioning and Heat Pump Appliances (Internal Combustion)*, 1996 reaffirmed 2012.

ANSI Z21.40.4/CSA 2.94, *Performance Testing and Rating of Gas-Fired, Air-Conditioning and Heat Pump Appliances*, 1996 reaffirmed 2012.

ANSI Z21.42, *Gas-Fired Illuminating Appliances*, 2013.

ANSI Z21.47/CSA 2.3, *Gas-Fired Central Furnaces*, 2012.

ANSI Z21.54/CSA 8.4, *Gas Hose Connectors for Portable Outdoor Gas-Fired Appliances*, 2014.

ANSI Z21.56/CSA 4.7, *Gas-Fired Pool Heaters*, 2014.

ANSI Z21.57, *Recreational Vehicle Cooking Gas Appliances*, 2010 reaffirmed 2015.

ANSI Z21.58/CSA 1.6, *Outdoor Cooking Gas Appliances*, 2015.

ANSI Z21.60/CSA 2.26, *Decorative Gas Appliances for Installation in Solid-Fuel Burning Fireplaces*, 2012.

ANSI Z21.61, *Gas-Fired Toilets*, 1993 reaffirmed 2013.

ANSI Z21.66/CSA 6.14, *Automatic Vent Damper Devices for Use with Gas-Fired Appliances*, 2015.

ANSI Z21.69/CSA 6.16, *Connectors for Movable Gas Appliances*, 2015.

ANSI Z21.71, *Automatic Intermittent Pilot Ignition Systems for Field Installations*, 1993 reaffirmed 2015.

ANSI Z21.77/CSA 6.23, *Manually-Operated Piezo-Electric Spark Gas Ignition Systems and Components*, 2015.

ANSI Z21.78/CSA 6.20, *Combination Gas Controls for Gas Appliances*, 2010 reaffirmed 2015.

ANSI Z21.84, *Manually Lighted, Natural Gas Decorative Gas Appliances for Installation in Solid-Fuel Burning Appliances*, 2012.

ANSI Z21.86/CSA 2.32, *Vented Gas-Fired Space Heating Appliances*, reaffirmed 2014.

ANSI Z21.87/CSA 4.6, *Automatic Gas Shutoff Devices for Hot Water Supply Systems*, 2007 reaffirmed 2012.

ANSI Z21.88/CSA 2.33, *Vented Gas Fireplace Heaters*, 2013.

ANSI Z21.91, *Ventless Firebox Enclosures for Gas-Fired Unvented Decorative Room Heaters*, 2007 reaffirmed 2012.

ANSI Z83.4/CSA 3.7, *Non-Recirculating Direct Gas-Fired Industrial Air Heaters*, 2015.

ANSI Z83.8/CSA 2.6, *Gas Unit Heaters, Gas Packaged Heaters, Gas Utility Heaters, and Gas-Fired Duct Furnaces*, 2016.

ANSI Z83.11/CSA 1.8, *Gas Food Service Equipment*, 2016.

ANSI Z83.19/CSA 2.35, *Gas-Fired High-Intensity Infrared Heaters*, 2009 reaffirmed 2014.

ANSI Z83.20/CSA 2.34, *Gas-Fired Low-Intensity Infrared Heaters*, 2008 reaffirmed 2013.

ANSI Z83.21/CSA C 22.2 No.168, *Commercial Dishwashers*, 2016.

NACE SP0169, *Control of External Corrosion on Underground or Submerged Metallic Piping Systems*, 2013.

K.2.3 MSS Publications. Manufacturers Standardization Society of the Valve and Fittings Industry, 127 Park Street, NE, Vienna, VA 22180-6671, www.msshq.org.

MSS SP-6, *Standard Finishes for Contact Faces of Pipe Flanges and Connecting-End Flanges of Valves and Fittings*, 2012.

ANSI/MSS SP-58, *Pipe Hangers and Supports — Materials, Design and Manufacture*, 2009.

K.2.4 SAE Publications. SAE International, 400 Commonwealth Drive, Warrendale, PA 15096, www.sae.org.

SAE J533, *Flares for Tubing*, 2007.

K.2.5 UL Publications. Underwriters Laboratories Inc., 333 Pfingsten Road, Northbrook, IL 60062-2096, www.ul.com.

ANSI/UL 103, *Chimneys, Factory-Built, Residential Type and Building Heating Appliances*, 2010, reapproved 2012.

ANSI/UL 441, *Gas Vents*, 2016.

ANSI/UL 641, *Type L Low-Temperature Venting Systems*, 2010, reapproved 2013.

ANSI/UL 1738, *Venting Systems for Gas Burning Appliances, Categories II, III and IV*, 2010, reapproved 2014.

ANSI/UL 1777, *Chimney Liners*, 2015.

▲ K.2.6 U.S. Government Publications. U.S. Government Publishing Office, 732 North Capitol Street, NW, Washington, DC 20401-0001, www.gpo.gov.

Title 24, Code of Federal Regulations, Part 3280, “*Manufactured Home Construction and Safety Standard*.”

K.3 References for Extracts in Informational Sections. (Reserved)

Index

Copyright © 2017 National Fire Protection Association. All Rights Reserved.

The copyright in this index is separate and distinct from the copyright in the document that it indexes. The licensing provisions set forth for the document are not applicable to this index. This index may not be reproduced in whole or in part by any means without the express written permission of NFPA.

-A-

- Aboveground piping**, 7.2, A.7.2.5
- Access doors and panels**, 10.10.3, 10.11.8, 10.26.1.5
- Accessible**
 - Appliances, 9.2.1, 9.4.3, 9.5.1
 - Definition, 3.3.1
 - Readily (definition), 3.3.1.1
 - Valves, 7.8.1, 7.8.2.1, 7.8.2.2
- Agency, qualified**, 4.1
 - Definition, 3.3.81
- Air**
 - Circulating, *see* Circulating air
 - Combustion, *see* Combustion air
 - Dilution, *see* Dilution air
 - Excess (definition), 3.3.2.3
 - Make-up, *see* Make-up air
 - Primary, *see* Primary air
 - Process, 9.1.7
 - Use under pressure, 9.1.5
- Air conditioning**
 - Appliances, 10.2, A.10.2.6
 - Definition, 3.3.3
- Aircraft hangars**
 - Duct furnaces in, 10.10.7
 - Heaters in, 9.1.12, 10.17.4, 10.25.5
- Air ducts**, *see* Ducts
- Altitude, high**, 11.1.2, 13.1.5, 13.2.11
- Anchors, pipe**, 7.2.6
- Anodeless risers**, 5.6.4.3
 - Definition, 3.3.4
- Appliance categorized vent diameter/area**, 13.1.9, 13.1.12, 13.1.13, 13.2.18, 13.2.24, F.2.3
 - Definition, 3.3.6
- Appliances**, *see also* Equipment
 - Air for combustion and ventilation, *see* Combustion air; Ventilation
 - Approval, 9.1.1, A.9.1.1
 - Attics, in, 9.5, 12.11.2.2
 - Automatically controlled, 10.15.2.2(3), 10.27.6, 12.3.2(5)
 - Clearances, Table 10.3.2.2
 - Definition, 3.3.5.1
 - Shutoff devices, 10.3.4, 10.3.5, 12.6.5.2, A.12.13.4
 - Temperature limit controls, 10.11.2
 - Venting, 12.4.4.1
 - Carpeting, installation on, 9.2.3
 - Categorized vent diameter/area, *see* Vent(s), Sizes
 - Clearance to combustible materials, 9.2.2, Table 10.3.2.2
 - Combination units, 9.1.21
 - Chimneys, 12.6.5.3, 12.6.5.4, A.12.6.5.3
 - Venting, Table 12.5.1
 - Connections to building piping, 9.6, A.9.6.1.5, A.9.6.3
 - Convenience outlets, 9.6.7
 - Converted, 9.1.2, 9.1.3
 - Counter (gas), *see* Food service appliances
 - Decorative, *see* Decorative appliances
 - Definition, 3.3.5
 - Direct vent, *see* Direct vent appliances
 - Electrical systems, 9.7
 - Existing, 9.1.24, 12.6.4.1, A.9.1.24, Annex G
 - Extra devices or attachments, 9.1.15
 - Fan-assisted combustion, *see* Fan-assisted combustion appliances
 - Food service, *see* Food service appliances
 - Household cooking, *see* Household cooking appliances
 - Illuminating, 10.15
 - Installation of, Chap. 9
 - Instructions
 - Installation, 9.1.22
 - Operating, 11.7
 - Louvers, grilles, and screens, 9.3.7, 10.8.5, 10.8.7.2, 10.9.5, 10.9.7.2, 10.26.1.5
 - Low-heat, *see* Nonresidential low-heat
 - Medium-heat, *see* Nonresidential medium-heat
 - Mobile, connections, 9.6.4
 - Nonresidential low-heat, 12.6.2.1, Table 12.8.4.4, 12.8.4.6(3), 12.11.2.4, A.12.6.2.1
 - Definition, 3.3.5.8
 - Nonresidential medium-heat, 12.6.2.2, Table 12.8.4.4, 12.11.2.5, 12.11.13.2
 - Definition, 3.3.5.9
 - Operation procedures, Chap. 11
 - Outdoor
 - Cooking appliances, 10.19
 - Definition, 3.3.5.10
 - Protection of, 9.1.23
 - Piping
 - Capacity of, 9.1.16
 - Strain on, 9.1.17
 - Placing in operation, 8.2.4, 8.3.3
 - Portable, connections, 9.6.4
 - Pressure regulators, 5.8.5.2, 9.1.18, 9.1.19
 - Protection, *see* Protection
 - Purging, 8.2.4, 8.3.3
 - On roofs, 9.4
 - Shutoff valves, *see* Valves
 - Type of gas(es), 9.1.3
 - Vented, *see* Vented appliances; Venting; Venting systems
 - In well-ventilated spaces, 12.3.4
- Applicability of code**, 1.1.1, A.1.1.1.1(A)
- Approved (definition)**, 3.2.1, A.3.2.1
- Atmospheric pressure**, A.12.1

Definition, 3.3.78.1
Attics, appliances in, 9.5, 12.11.2.2
Authority having jurisdiction (definition), 3.2.2, A.3.2.2
Automatic firechecks, 7.11.1(3), 7.11.6, A.7.11.4, A.7.11.6(1)
 Definition, 3.3.7
Automatic gas shutoff devices, 5.9.3.1(4), 7.11.5.4, 10.3.5, 10.27.5,
 A.7.11.5.4, A.12.13.4
 Definition, 3.3.28.1
Automatic ignition, *see* Ignition
Automatic valves, *see* Valves
Automatic vent dampers, 12.15, 12.16(3)
 Definition, 3.3.8

-B-

Backfilling, 7.1.2.3
Backfire preventers, *see* Safety blowouts
Back pressure
 Definition, 3.3.78.2
 Protection, 5.10
Baffle, 10.12.3.2(1), 12.14
 Definition, 3.3.10
Barometric draft regulators, 9.3.1.4, 12.13.4 to 12.13.6, A.12.13.4
 Definition, 3.3.84.1.1
Bathroom, installation in, 10.1.2, 10.22.1, A.10.1.2, A.10.22.1
Bedroom, installation in, 10.1.2, 10.22.1, A.10.1.2, A.10.22.1
Bends, pipe, 7.5
Bleeds
 Diaphragm-type valves, 9.1.20
 Industrial air heaters, 10.8.6, 10.9.6
Blowers, mixing, *see* Mixing blowers
Boilers
 Central heating, 10.3, A.10.3.6, A.10.3.7.3
 Assembly and installation, 10.3.3
 Clearance, 10.3.2, Table 12.8.4.4
 Cooling units used with, 10.3.9
 Low-water cutoff, 10.3.5, 11.5
 Steam safety and pressure relief valves, 10.3.6, A.10.3.6
 Temperature or pressure limiting devices, 10.3.4
 Hot water heating, Table 10.3.2.2, 10.3.4, 10.3.6, 10.3.9.2,
 A.10.3.6
 Definition, 3.3.11.1
 Hot water supply, Table 10.3.2.2, 10.3.4, 10.3.6, A.10.3.6
 Definition, 3.3.11.2
 Low pressure, A.10.3.6
 Clearances, 10.3.2.1 to 10.3.2.3
 Definition, 3.3.11.3
 Location, 10.3.1
 Steam, Table 10.3.2.2, 10.3.4 to 10.3.6
 Definition, 3.3.11.4
Bonding, electrical, 7.12, A.7.12.2 to A.7.12.5
Bonding jumper, 7.12.2.1 to 7.12.2.3
 Definition, 3.3.12
Branch lines, 7.4.1
 Branch length pipe sizing method, 6.1.2, A.6.1.2, B.4.2, B.7.3,
 B.7.4
 Definition, 3.3.13
 Pressure testing, 8.1.1.4
Breeching, *see* Vent connectors

Broilers
 Definition, 3.3.15
 Household cooking appliance
 Definition, 3.3.5.7.1
 Protection above, 10.18.3
 Unit
 Commercial, 10.18.4
 Definition, 3.3.15.1
 Domestic, protection above, 10.18.3
 Open-top, 10.18
Btu (definition), 3.3.16
Buildings
 Piping in
 Building structure for, 7.2.3
 Concealed, 7.3
 Connection of appliances and equipment to, 9.6, A.9.6.1.5,
 A.9.6.3
 Prohibited locations, 7.2.5, A.7.2.5
 Piping under, 7.1.6
 Structure, 9.1.8
Built-in household cooking units, *see* Household cooking appliances
Burners
 Combination gas and oil burners
 Chimneys for, 12.6.5.3, 12.6.5.4, A.12.6.5.3
 Venting system, Table 12.5.1
 Definition, 3.3.17
 Forced draft, *see* Power
 Gas conversion, 10.5
 Definition, 3.3.17.2
 Injection- (Bunsen-type), 9.6.3, A.9.6.3
 Definition, 3.3.17.3
 Input adjustment, 11.1, A.11.1.1
 Power, 9.3.1.2
 Definition, 3.3.17.5
 Fan-assisted (definition), 3.3.17.5.1
 Primary air adjustment, 11.2, A.11.2
 In residential garages, 9.1.10.1
Butane, 5.5.5
Bypass piping, 5.8.6
Bypass valves
 Gas line pressure regulators, 5.8.6
 Pool heaters, 10.20.4

-C-

Capping, of outlets, 7.7.2
Carpeting, installation of appliances on, 9.2.3
Casters, for floor-mounted food service appliances, 10.12.6
Central furnaces, *see* Furnaces
Central premix system, 7.11, A.7.11.4 to A.7.11.6(1)
 Definition, 3.3.95.1
Chases, vertical, piping in, 7.4, A.7.4.3
Chimneys, Table 12.5.1, 12.6, A.12.6.1.3 to A.12.6.5.3
 Cleanouts, 12.6.4.3, 12.6.7
 Clothes dryer exhaust duct, 10.4.4.1
 Decorative appliance installation, 10.6.2
 Definition, 3.3.18
 Exterior masonry, Table 13.1(f), Tables 13.2(f) to (i), F.2.4

- Definition, 3.3.18.1
- Factory-built, 9.3.8.7, 12.6.1.1, 12.6.2.4, 12.6.6, 12.6.8.2, 12.6.9, 12.11.2.4, 12.11.2.5(4)
 - Definition, 3.3.18.2
- Gas piping in, 7.2.5, A.7.2.5
- Masonry, 9.3.8.7, 12.6.1.3, 12.6.8.1, 12.6.8.2, 12.7.2(3), Table 13.1(c), Table 13.1(d), Table 13.1(f), 13.1.7, 13.2.20, 13.2.23, A.12.6.1.3, A.13.1.7, A.13.2.20, F.2.3
 - Definition, 3.3.18.3
- Metal, 9.3.8.7, 12.6.1.2, 12.6.8.2
 - Definition, 3.3.18.4
- Obstructions, 12.16, 13.1.1
- Vent connectors, 12.11.1, 12.11.2.4, 12.11.2.5, 12.11.3.3, 12.11.10
- Venting system, Table 12.5.1, 12.7.4.4, Table 13(c), Table 13(d), Table 13.1(f), 13.1.7, 13.1.11, Table 13.2(c), Table 13.2(d), Tables 13.2(f) to (i), 13.2.20, 13.2.21, A.13.1.7, A.13.2.20, F.2.3
- Circuits, electrical**, 7.13, 9.7.3
- Circulating air**, 10.7.3, 10.10.5, 10.11.3, 10.25.3, 10.26.3
 - Definition, 3.3.2.1
- Clearances**, 9.2.2
 - Air-conditioning equipment, indoor installation, 10.2.3
 - Boilers, central heating, 10.3.2, Table 12.8.4.4
 - Clothes dryers, 10.4.1
 - Draft hoods, 12.13.7
 - Food service appliances
 - Above cooking top, A.10.14.1
 - Counter appliances, 10.13.1 to 10.13.3
 - Floor-mounted, 10.12.1, 10.12.2
 - Outdoor cooking appliances, 10.19.2
 - Furnaces
 - Central, 10.3.2
 - For connectors, Table 12.8.4.4
 - Duct, 10.10.1
 - Floor, 10.11.7
 - Gas-fired toilets, 10.24.1
 - Heaters
 - Industrial air, 10.8.4, 10.9.4
 - Infrared, 10.17.2
 - Pool, 10.20.2
 - Room, 10.22.4
 - Unit, 10.25.2
 - Water, 10.27.2
 - Household cooking appliances, 10.14.2, A.10.14.1
 - Illuminating appliances, 10.15.1, 10.15.2
 - Refrigerators, gas, 10.21.1
 - Single-wall metal pipe for vents, 12.8.4.4
 - Underground piping, 7.1.1
 - Vent connectors, 12.11.5
- Clothes dryers**
 - Definition, 3.3.19
 - Installation, 10.4
 - Multiple family or public use, 10.4.5.6, 10.4.6
 - Type 1, 10.4.1(1), 10.4.2, 10.4.4, 12.3.2(4)
 - Definition, 3.3.19.1
 - Type 2, 10.4.1(2), 10.4.2, 10.4.5
 - Definition, 3.3.19.2
 - Venting, 9.3.1.5, 10.4.2 to 10.4.5, 12.3.2(4)
- Coal basket**, *see* Decorative appliances for installation in vented fireplaces
- Code (definition)**, 3.2.3, A.3.2.3
- Code enforcement**, Annex J
- Combustible gas detector**, 8.3.2.2
- Combustible gas indicator**, 8.3.1.4, A.8.3.1.4
- Combustible material**
 - Clearances to, *see* Clearances
 - Definition, 3.3.64.1, A.3.3.64.1
 - Food service appliances mounted on/adjacent to, 10.12.3, 10.12.5, 10.13.4
 - Household cooking appliances mounted on/adjacent to, 10.14.2
 - Roof or exterior walls, metal pipe passing through, 12.8.4.5, 12.8.4.6
- Combustion (definition)**, 3.3.20
- Combustion air**, 9.1.2(1), 9.3, 12.9.5, A.9.3
 - Combination indoor and outdoor, 9.3.4, Annex I
 - Ducts, 9.3.8
 - Engineered installations, 9.3.5
 - Floor furnaces, 10.11.3
 - Gas fireplaces, vented, 10.7.3
 - Indoor, 9.3.2, A.9.3.2.1 to A.9.3.2.3(1)
 - Calculation examples, Annex H, Annex I
 - Infrared heaters, 10.17.3
 - Mechanical supply, 9.3.6
 - Outdoor, 9.3.3, A.9.3.3.1(1) to A.9.3.3.2
 - Calculation examples, Annex I
 - Unit heaters, 10.25.3
 - Wall heaters, 10.26.3
- Combustion chamber**, 8.3.2.1(2), 9.1.19, 9.1.20, 10.22.4(1)
 - Definition, 3.3.21
- Combustion products**, 10.21.2, 12.9.5
 - Definition, 3.3.22
- Commercial cooking appliances**, *see* Food service appliances
- Common vent**, *see* Gas vents
- Common vent manifolds**, *see* Manifolds
- Compressed natural gas (CNG) vehicular fuel systems**, 10.28
- Concealed gas piping**
 - In buildings, 7.3
 - Definition, 3.3.76.1
- Condensate (condensation)**
 - Definition, 3.3.23
 - Drain, 12.10
- Connections**
 - Air conditioners, 10.2.2
 - Chimney, 12.11.10
 - Electrical, 7.14, 9.7.1
 - Equipment and appliances, 9.6, A.9.6.1.5, A.9.6.3
 - Gas, 5.14.2
 - Branch, 7.4.1
 - Concealed piping, 7.3.2
 - Plastic and metallic piping, 7.1.7.1, 7.1.7.2
 - Outdoor open flame decorative appliances, 10.31.3
 - Portable and mobile industrial appliances, 9.6.4
- Connectors**
 - Gas hose, to appliances and equipment, 9.6.2

Vent, *see* Vent connectors

Construction

- Chase, 7.4.2
- Overpressure protection devices, 5.9.4
- Single-wall metal pipe, 12.8.1

Control piping

- Definition, 3.3.76.2
- Overpressure protection devices, 5.9.5

Controls

- Definition, 3.3.24
- Draft, 12.13, 12.16, A.12.13.4
- Duct furnaces, 10.10.4
- Inspections, 11.5
- As obstructions, 12.16
- Safety shutoff devices, *see* Safety shutoff devices

Convenience outlets, *see* Gas convenience outlets

Conversion burners, gas, 10.5

- Definition, 3.3.17.2

Cooking appliances, *see* Food service appliances; Household cooking appliances

Cooling units, *see also* Refrigeration systems

- Boilers, used with, 10.3.9

Copper alloy, 5.6.2.3, 5.6.2.4, 5.6.3.4, 5.6.7.5, 5.6.9.1.3, Table A.5.6, A.5.6.2.3, A.5.6.3.4, A.7.12.2, B.4.1, G.3.2

- Definition, 3.3.25

Corrosion, protection against, 5.6.2.4, 5.6.2.5, 5.6.3.5, 7.1.3, 7.2.2, 7.3.5.1, 7.3.5.2, 12.6.1.3(3), A.7.1.3

Counter appliances, gas, *see* Food service appliances

CSSST pipe and fittings, Tables 6.2(o) to (s), Tables 6.3.1(h) to (j), 7.2.6.2, 7.2.7, 7.12.2, Table 8.3.1, 9.6.1(5), Table A.5.6, A.7.12.2, B.7.2, B.7.4

Cubic feet (cu ft.) of gas (definition), 3.3.26

-D-

Dampers

- Automatically operated vent, 12.15
- Chimney, free opening area of, Table 10.6.2.3
- Gravity, 10.8.7.2, 10.9.7.2
- Manually operated, 12.14
- Obstructions and, 13.1.1
- Outside, 10.8.5, 10.9.5

Decorative appliances, outdoor open flame, 10.31

Decorative appliances for installation in vented fireplaces, 9.6.5.1(B), 10.6, Table 12.5.1, A.10.6.1

- Definition, 3.3.5.2

Deep fat fryers, 10.12.1

- Definition, 3.3.5.5.3

Defects, detection of, 5.6.5, 8.1.5

Definitions, Chap. 3

Design pressure

- Allowable pressure drop, 5.4.4, B.7.5, B.7.6
- Definition, 3.3.78.3
- Maximum, 5.5.1, 5.5.4, A.5.5.4(1)

Detectors, leak, 8.1.5

Devices, *see also* Quick-disconnect devices; Safety shutoff devices

- Automatic gas shutoff devices, 10.27.5
- Definition, 3.3.28.1

Dilution air, 9.3.1.1 to 9.3.1.3, 9.3.5, 9.3.7.1

- Definition, 3.3.2.2

Direct gas-fired industrial air heaters

- Air supply, 10.8.5, 10.9.5
- Nonrecirculating, 10.8

 - Definition, 3.3.56.1

- Prohibited installations, 10.9.2, A.10.9.2.2
- Recirculating, 10.9, A.10.9.2.2

 - Definition, 3.3.56.2

- Venting of, 12.7.3(1)(d)
- In well-ventilated spaces, 12.3.4

Direct gas-fired makeup air heaters, venting of, 12.3.2(9)

Direct vent appliances

- Definition, 3.3.5.3
- Venting of, 12.3.5, Table 12.5.1, 12.7.3(1)(d), 12.9.1 Ex. 1, 12.9.3, 12.9.5, 12.9.6

Direct vent wall furnaces, *see* Furnaces

Diversity factor, 5.4.2.3 Ex., A.5.4.1(5), B.2(5)

- Definition, 3.3.29

Draft(s), 9.8.2

- Checking, 11.6, A.11.6
- Definition, 3.3.30
- Mechanical, 12.4.3, 12.7.3(1)(f), 12.7.4.4, 12.9.1, 12.9.2, 12.11.4.3

 - Definition, 3.3.30.1

- Natural, 9.3.1.2, 12.4.3.4, 12.7.4.1, A.12.7.4.1, G.5.2

 - Definition, 3.3.30.2

- Requirements, 12.4.1

Draft controls, 12.13, 12.16, A.12.13.4

Draft hoods, 9.3.1.4

- Central heating boilers and furnaces, Table 10.3.2.2, 10.3.2.6
- Checking the draft, 11.6, A.11.6
- Chimneys, 12.6.1.3 Ex., 12.6.2.3, 12.6.3.1
- Conversion accessories, 13.1.10, 13.2.23
- Definition, 3.3.31
- Duct furnaces, 10.10.1, 10.10.4
- Food service appliances, 10.12.1, 10.13.2
- Gas fireplaces, 10.7.2(2)
- Pool heaters, 10.20.2
- Unit heaters, 10.25.2.1
- Vents and venting systems, Table 12.5.1, 12.7.2(4), 12.7.4.1, Table 12.8.4.4, 12.8.4.6, 12.8.5(1), 12.11.2.2, 12.11.2.3, 12.11.3, 12.13, Table 13.1(e), 13.1.2, 13.1.4, 13.1.10, 13.1.11(3), Table 13.2(e), 13.2.12, 13.2.13, 13.2.18, 13.2.22(2), 13.2.23, 13.2.24, A.12.7.4.1, A.12.8.5(1), A.12.11.3, A.12.13.4, Annex F
- Water heaters, 10.27.2.1

Draft regulators, 12.16 *see also* Barometric draft regulators

- Definition, 3.3.84.1

Drain, condensation, 12.10

Drip liquids, 4.3.2.1

Drips, 7.6

- Definition, 3.3.32

Dry gas, 7.2.4, 7.6.1

- Definition, 3.3.33

Duct furnaces, *see* Furnaces

Ducts

- Air, 9.3.8, 10.2.3(5), 10.2.5, 10.3.7, 10.8.5, 12.4.5, A.10.3.7.3
- Exhaust, 10.4.4, 10.4.5

Unit heaters, 10.25.4

-E-

Effective ground-fault current path, 7.12.1, 7.12.3

Definition, 3.3.34

Elbows, 7.5.3, 13.1.3, 13.2.6, 13.2.7

Electrical systems, 7.12 to 7.14, A.7.12.2 to A.7.12.5

Air conditioning equipment, 10.2.7

Gas utilization equipment, 9.7

Ignition and control devices, 9.7.2

Enclosed furnaces, 10.11.11, 10.11.12

Definition, 3.3.45.4

Enforcement of code, 1.5, Annex J

Engines, stationary gas, 10.23

Equipment, *see also* Appliances

Added or converted, 9.1.2, 9.1.3

Approval, 9.1.1, A.9.1.1

Bleed lines for diaphragm-type valves, 9.1.20

Combination, 9.1.21

Connections to building piping, 9.6, A.9.6.1.5, A.9.6.3

Definition, 3.3.35

Installation, Chap. 9

Instructions

Installation, 9.1.22

Operating, 11.7

Outdoor, protection of, 9.1.23

Placing in operation, 8.2.4, 8.3.3

Equipment shutoff valves, *see* Valves

Equivalency to code, 1.4

Excess air (definition), 3.3.2.3

Excess flow valve (EFV), 5.13

Definition, 3.3.99.3

Exhaust systems, mechanical, *see* Mechanical exhaust systems

Explosion heads (soft heads or rupture discs), 7.11.6(4)

Definition, 3.3.36

Exterior masonry chimneys, *see* Chimneys

-F-

Fan-assisted combustion appliances, 9.3.2.2, 13.1.1(2), 13.1.2, 13.1.10, 13.2.3(2), 13.2.23, 13.2.24, Table A.9.3.2.2(b), H.1 to H.3, I.1

Definition, 3.3.5.4

Venting system, 12.7.4.1(2), 12.11.3.1, 12.13.1 Ex., A.12.7.4.1, F.1.2, F.2.2 to F.2.4

Fan-assisted combustion system (definition), 3.3.95.2; *see also* Fan-assisted combustion appliances

Fan-assisted power burners (definition), 3.3.17.5.1

FAN+FAN, Tables 13.2(a) to (d), 13.2.1(3)

Definition, 3.3.39

FAN Max, Tables 13.1(a) to (d), 13.1.6, Tables 13.2(a) to (d), 13.2.3(1), 13.2.19

Definition, 3.3.37

FAN Min, Tables 13.1(a) to (d), 13.1.1(2), 13.1.6, Tables 13.2(a) to (d), 13.2.1(3), 13.2.3(2), 13.2.19

Definition, 3.3.38

FAN+NAT, Tables 13.2(a) to (d), Table 13.2(h), Table 13.2(i), 13.2.1(2), 13.2.1(3), 13.2.22(3), 13.2.22(4)

Definition, 3.3.40

Firechecks, *see* Automatic firechecks

Fireplace insert, *see* Decorative appliances for installation in vented fireplaces

Fireplaces, *see also* Decorative appliances for installation in vented fireplaces

Definition, 3.3.41

Gas, *see* Gas fireplaces

Outlets, capping, 7.7.2.2

Shutoff valves, 9.6.5.1(B)

Vent connectors, 12.11.12

Fireplace screens, 10.6.3

Fittings

Appliance and equipment connections, 9.6.1(1), 9.6.1(2)

Concealed piping, 7.3.2

Corrosion, protection against, 7.1.3, 7.3.5.2, A.7.1.3

Gas pipe turns, 7.5

Metallic, 5.6.7, A.5.6.7.1

Overpressure relief device, 5.9.9

Plastic, 5.6.4, 5.6.8, A.5.6.4.2

Used, 5.6.1.2

Workmanship and defects, 5.6.5

Flame arresters, 7.11.2(2)

Definition, 3.3.42

Flammable liquids, handling of, 4.3.2

Flammable vapors, appliances in area of, 9.1.9

Flange gaskets, 5.6.10

Flanges, 5.6.9

Floor furnaces, *see* Furnaces

Floor-mounted equipment

Food service, 10.12, A.10.12.8

Household cooking appliances, 10.14.1, 10.14.2

Floors, piping in, 7.3.5, 12.11.13

Flowmeters, 7.11.2(1)

Flue collars, 12.6.2.3, 12.7.2(4), 13.1.4, 13.1.9

Chimney size, 12.6.3.1(2)

Definition, 3.3.44

Draft control devices, 12.13.3

Draft hood size, 12.13.2.1

Joints, 12.11.6

Multiple, on single appliance, 12.11.3.2

Single-wall metal pipe size, 12.8.5(1), A.12.8.5(1)

Single-wall metal pipe termination, 12.8.3(1)

Vent connector sizing, 12.7.5.3, 12.11.3.6, 13.1.12, 13.1.13, 13.2.24

Vent size, 13.1.2, 13.2.18

Flue gases

Definition, 3.3.49.1

Venting of, 9.1.14

Flues

Appliance

Bleed lines, termination of, 9.1.20(3)

Collars, 13.1.9

Chimney size, 12.6.3.1(2)

Draft control devices, 12.13.3

Draft hood size, 12.13.2.1

Multiple, on single appliance, 12.11.3.2

Single-wall metal pipe size, 12.8.5(1), A.12.8.5(1)

- Vent connector sizing, 13.2.24
 - Vent sizing, 13.1.2, 13.2.24
 - Definition, 3.3.43.1
 - Regulator, venting of, 5.8.5.1(5), 9.1.19
 - Chimney, 10.6.2, 12.6.1.3 Ex., 12.6.3.1(2), 12.6.5, 12.6.5.1, 12.6.8.2, 12.11.4.1, 12.11.4.2, 12.11.10, 12.11.12, 13.1.11, 13.2.22, A.12.6.5.3
 - Definition, 3.3.43.2
 - Food service appliances**, *see also* Broilers; Household cooking appliances
 - Clearances, *see* Clearances
 - Combustible material adjacent to cooking top, 10.12.5
 - Connectors, 9.6.1.3
 - Counter appliances, 10.13, 12.3.2(7)
 - Definition, 3.3.5.5.2
 - Deep fat fryers, 10.12.1
 - Definition, 3.3.5.5.3
 - Floor-mounted, 10.12, A.10.12.8
 - Kettle, 10.12.1
 - Definition, 3.3.5.5.7
 - Oven, baking and roasting, 10.12.1
 - Definition, 3.3.5.5.1
 - Range, 12.3.2(1)
 - Definition, 3.3.5.5.4
 - Steam cooker, 10.12.1
 - Definition, 3.3.5.5.5
 - Steam generator, 10.12.1
 - Definition, 3.3.5.5.6
 - Venting, 12.3.2(1) to (3), 12.3.2(7)
 - Forced-air furnaces**, *see* Furnaces
 - Forced-draft burners**, *see* Burners
 - Foundations, piping through**, 7.1.5
 - Freezing, protection against**, 7.1.4, A.7.1.4
 - Fuel cell power plants**, 10.30
 - Furnace plenums**, 10.2.3(4), 10.2.3(5), 10.2.5, 10.3.2.7, 10.3.7, 12.4.5, A.10.3.7.3
 - Definition, 3.3.46
 - Furnaces**
 - Central, 10.3, A.10.3.6, A.10.3.7.3
 - Definition, 3.3.45.1
 - Clearances, *see* Clearances
 - Direct vent, 10.26.1.4, Table G.6
 - Definition, 3.3.45.2
 - Duct, 10.10
 - In commercial garages and aircraft hangars, 10.10.7
 - Definition, 3.3.45.3
 - Use with refrigeration systems, 10.10.6
 - Enclosed, 10.11.11, 10.11.12
 - Definition, 3.3.45.4
 - Floor, 10.11
 - Definition, 3.3.45.5
 - First floor installation, 10.11.12
 - Upper floor installation, 10.11.11
 - Forced-air, Table 10.3.2.2, G.6.1
 - With cooling unit, 10.3.8(1)
 - Definition, 3.3.45.6
 - Refrigeration coils and, 10.3.8
 - Vented wall, 10.26.1.3, 10.26.1.4, Table 12.5.1, Table G.6, G.6.5
 - Definition, 3.3.45.7
 - Wall, 10.26, Table G.6
 - Direct vent, *see* subhead: Direct vent
 - Vented, *see* subhead: Vented wall
- G-**
- Garages**
 - Commercial
 - Appliances in, 9.1.11
 - Duct furnaces in, 10.10.7
 - Heaters in, 10.17.4, 10.25.5
 - Repair
 - Appliances in, 9.1.11.2
 - Definition, 3.3.47.1
 - Residential
 - Appliances in, 9.1.10
 - Definition, 3.3.47.2
 - Gas air mixtures**
 - Flammable, 7.11, A.7.11.4 to A.7.11.6(1)
 - Operating pressure, maximum, 5.5.2
 - Outside the flammable range, 7.10
 - Gas appliance pressure regulators**, 5.8.5.2, 9.1.18
 - Definition, 3.3.84.2
 - Illuminating appliances, 10.15.5
 - Venting of, 9.1.19
 - Gas appliances**, *see* Appliances
 - Gas convenience outlets**, 7.7.1.6, 9.6.7
 - Definition, 3.3.48
 - Gases**
 - Definition, 3.3.49
 - Dry, *see* Dry gas
 - Flue
 - Definition, 3.3.49.1
 - Venting of, 9.1.14
 - LP-Gas systems, *see* LP-Gas systems
 - Maximum demand, 5.4.1, 5.4.2, A.5.4.1, A.5.4.2
 - Purged, discharge of, 8.3.1.3
 - Used in appliances, 9.1.3
 - Utility
 - Definition, 3.3.49.2
 - Fixed orifices, flow of gas through, Annex E
 - Vent (definition), 3.3.49.3
 - Gas-fired air conditioners**, 10.2, A.10.2.6
 - Definition, 3.3.50
 - Gas-fired heat pumps**, 10.2, A.10.2.6
 - Definition, 3.3.51
 - Gas fireplaces**, *see also* Decorative appliances for installation in vented fireplaces
 - Direct vent, 10.7.1 Ex., 10.7.2(4), Table A.5.4.2.1
 - Definition, 3.3.41.1.1
 - Vented, 10.7, A.10.7.1
 - Definition, 3.3.41.1.2
 - Gaskets, flange**, 5.6.10
 - Gas log**, *see* Decorative appliances for installation in vented fireplaces
 - Gas-mixing machines**, 7.10, 7.11.1(1), 7.11.3
 - Definition, 3.3.52

Installation, 7.11.5, A.7.11.5.1, A.7.11.5.4

Gas range, 12.3.2(1)
Definition, 3.3.5.5.4

Gas reliefs, 10.8.6, 10.9.6

Gas supplier regulations, 1.1.2

Gas utilization equipment, *see* Equipment

Gas vents, 12.7, A.12.7.4.1
Common, 12.7.5, 12.11.3.5, 12.11.3.6, 13.2.4 to 13.2.10, A.12.7.5.2, Fig. F.1(k), Fig. F.1(1), F.2
Definition, 3.3.53.1
Connectors, *see* Vent connectors
Definition, 3.3.53, A.3.3.53
Integral, appliances with, 12.3.6
Integral, equipment with, Table 12.5.1, 12.7.3(1)(e)
Multistory design, Fig. F.1(m), Fig. F.1(n)
Serving equipment on more than one floor, 12.7.5, A.12.7.5.2
Spaces surrounding, 12.6.8
Special-type, 12.5.4, 12.6.8
Definition, 3.3.53.2
Type B, Table 12.5.1, 12.6.1.3 Ex., 12.6.3.1, 12.7.1, 12.7.3(2), 12.7.4.1, 12.7.4.2, 12.7.5.3, Table 12.8.4.4, 12.8.4.6(1), 12.11.2.2, 12.11.2.3(1)(a), 12.11.8.2, Table 13.1(a), Table 13.1(b), Table 13.1(e), 13.1.7, 13.1.11, Tables 13.2(a) to (c), Tables 13.2(f) to (i), 13.2.20, 13.2.22, A.12.7.4.1, A.13.1.7, A.13.2.20, Annex F
Definition, 3.3.53.3
Type B-W, Table 12.5.1, 12.7.1, 12.7.2(2), 12.7.3(3)
Definition, 3.3.53.4
Type L, Table 12.5.1, 12.7.3(2), 12.7.4.2, Table 12.8.4.4, 12.11.2.2, 12.11.2.3(1)(a)
Definition, 3.3.53.5
Wall heaters, 10.26.1.3, 10.26.1.4

Governor, zero, 7.11.4, A.7.11.4
Definition, 3.3.105

Gravity, *see* Specific gravity

Gravity furnaces, *see* Furnaces

Grilles, 9.3.7, 10.26.1.5

Grounding, electrical, 7.12, A.7.12.2 to A.7.12.5

Grounding electrode, 7.12.2, 7.12.4, A.7.12.2
Definition, 3.3.55

-H-

Hangars, *see* Aircraft hangars

Hangers, pipe, 7.2.6

Health care occupancy, 10.22.3(2)
Definition, 3.3.70.1

Heaters, *see also* Direct gas-fired industrial air heaters; Infrared heaters; Room heaters; Water heaters
In aircraft hangars, 9.1.12, 10.17.4, 10.25.5
In commercial garages, 10.17.4, 10.25.5
Direct gas-fired makeup air, 12.3.2(9)
Pool, 10.20
Definition, 3.3.56.4
Unit, 10.25
Definition, 3.3.56.5

Heating value (total) (definition), 3.3.57

Heat pumps, *see* Gas-fired heat pumps

Heat reclaimers, 12.16

High altitude, *see* Altitude, high

Hoods
Draft, *see* Draft hoods
Ventilating, *see* Ventilating hoods

Hoop stress, 8.1.4.2
Definition, 3.3.94.1

Hot plates
Commercial counter appliances, 10.13
Definition, 3.3.5.5.2
Domestic
Definition, 3.3.58.1
Venting, 12.3.2(3)

Household cooking appliances, 10.14, A.10.14.1
Broilers
Definition, 3.3.5.7.1
Protection above, 10.18.3
Built-in units, 10.14.1, 10.14.2(4), 12.3.2(2), Table A.5.4.2.1
Definition, 3.3.5.7.2
Definition, 3.3.5.7
Floor-mounted, 10.14.1, 10.14.2
Outdoor, 10.19
Definition, 3.3.5.10

Hybrid pressure system
Definition, 3.3.95.3
Pipe sizing, 6.1.3, B.4.3, B.7.2

-I-

Identification
Meters, 5.7.5
Pressure regulators, 5.8.7

Ignition
Accidental, prevention of, 4.3
Automatic, 11.4
Definition, 3.3.59.1
Electrical, 9.7.2
Sources, 4.3.1
Definition, 3.3.59.2

Illuminating appliances, 10.15

Incinerators
Commercial-industrial, 10.16, 12.3.7
Venting, 12.3.7, Table 12.5.1

Industrial air heaters, *see* Direct gas-fired industrial air heaters

Infrared heaters, 10.17
Definition, 3.3.56.3
Suspended low-intensity tube, 9.6.1.5, A.9.6.1.5

Injection- (Bunsen-type) burners, *see* Burners

Inspections
Chimneys, 12.6.4
Draft, 11.6, A.11.6
Existing installation, Annex G
Gas piping, 8.1, A.8.1.1 to A.8.1.4.3
Ignition, automatic, 11.4
Protective devices, 11.5
Safety shutoff devices, 11.3
Vent connectors, 12.11.11

Installations
Appliances, equipment, and accessories, Chap. 9

Chimneys, 12.6.1, 12.6.2, A.12.6.1.3, A.12.6.2.1
 Draft hoods and draft controls, 12.7.2(4), 12.13.1 to 12.3.3
 Electrical, 9.7
 Gas piping, 5.1.1, Chap. 7
 Overpressure protection devices, 5.9.4
 Pressure relieving/pressure limiting devices, 5.9.4
 Roofs, appliances on, 9.4.2
 Single-wall metal pipe for vents, 12.8.4, A.12.8.4.1
 Specific appliances, Chap. 10

Instructions

Appliance and equipment installation, 9.1.22
 Manufacturers, 1.1.2
 Operating, 11.7

Insulating millboard

Definition, 3.3.60

Insulation shield, 12.6.9**Interruption of service**, 4.2**Interruption of work**, 4.2.2**J-****Joining methods**, 5.6, A.5.6**Joint compounds, thread**, *see* Thread joint compounds**Joints**

Flared, 5.6.7.4
 Metallic, 5.6.7, A.5.6.7.1
 Plastic, 5.6.8, 7.5.2(2), 12.5.3
 Tubing, 5.6.7.2, 5.6.7.3
 Vent connectors, 12.11.6

-K-**Kettle, gas-fired**, 10.12.1

Definition, 3.3.5.5.7

-L-**Labeled (definition)**, 3.2.4**Laboratories, shutoff valve for**, 7.8.2.4**Leakage**

Check, Annex C
 Emergency procedure for, Annex D
 Pressure test, 8.1.5.1

Leak check, 8.2, A.8.2.3, Annex C**Leak detectors**, 8.1.5**Lightning protection**, 7.12.5, A.7.12.5**Limit controls**, 11.5 *see also* Temperature limit controls/devices

Definition, 3.3.24.1

Line pressure regulators, 5.8.1, 5.8.2, 5.9.2.1, 5.9.2.5, 5.9.3.1, 5.9.3.2, 6.1.3, Table 6.3.1(c), Table 6.3.1(g), Table 6.3.1(i), Table 6.3.1(l), C.3

Bypass piping, 5.8.6

Definition, 3.3.84.3

Identification, 5.8.7

Venting, 5.8.5.1

Listed (definition), 3.2.5, A.3.2.5**Longest length pipe sizing method**, 6.1.1, A.6.1.1, B.4.1, B.7.1**Louvers**, 9.3.7, 10.8.5, 10.8.7.2, 10.9.5, 10.9.7.2**LP-Gas systems**, 5.6.6.4, 9.1.4, A.5.6.6.4

Fixed orifices, flow of gas through, Table E.1.1(b)

High-pressure gas formula, Table 6.4.2

Leakage check, C.3(2)

Operating pressure, maximum, 5.5.3, 5.5.5

Pipe sizing tables, 6.3, B.3.3

Plastic pipe, use of, 5.6.8(4)

-M-**Main burners**

Air supply, 9.3.6.2, 10.8.5, 10.9.5

Backdraft or fuel spillage, 12.6.5.3, A.12.6.5.3

Dampers or louvers, open, 9.3.7.3, 10.8.7.2, 10.9.7.2, 12.4.4.1

Definition, 3.3.17.4

Draft system operation and, 11.6, 12.4.3.5, A.11.6

Make-up air, 9.3.1.5, 10.4.3

Direct gas-fired make-up air heaters, 12.3.2(9)

Manifolds

Common vent, 9.1.19(6), 9.1.20(5), 12.11.3.5, 12.11.3.6, 13.2.4, Fig. F.1(k)

Definition, 3.3.62.1

Gas, 5.8.5.1(1), 9.6.5.3, 12.11.3.2, G.4.1

Definition, 3.3.62.2

Manual reset valves, *see* Valves, Manual reset**Manufactured homes**

Appliances for, 10.29

Definition, 3.3.63

Manufacturer's instructions, 1.1.2**Marking**

Gas vents, 12.7.7

Single-wall metallic pipe, 12.8.7

Masonry chimneys, *see* Chimneys**Material**, *see* Combustible material; Noncombustible material**Maximum working pressure**, 8.1.4.2

Definition, 3.3.78.4

Mechanical draft, *see* Draft(s)**Mechanical exhaust systems**, 9.3.1.5, 12.3.2(5), 12.4.4, 12.7.3(1)(f), A.12.4.4

Clothes dryers, 10.4.2, 10.4.4, 10.4.5

Definition, 3.3.95.4

Mechanical venting systems, *see* Venting systems**Metallic pipe**, 5.6.2, A.5.6.2.3; *see also* Tubing

Appliance and equipment connections, 9.6.1(1), 9.6.1(2)

Connection to plastic piping, 7.1.7.2

Corrosion, protection against, 5.6.2.4, 5.6.2.5, 5.6.3.5, 7.1.3, 7.2.2, 7.3.5.1, 7.3.5.2, A.7.1.3

Joints and fittings, 5.6.7, A.5.6.7.1

Low pressure gas pipe sizing tables, B.3.2

Single-wall, for venting, 12.7.2(4), 12.8, Table 12.8.4.4, 12.11.1, 12.11.2.2 Ex., Table 13.1(e), Table 13.2(e), 13.2.25, A.12.8.2 to A.12.8.5(1)

Sizing, Tables 6.2(a) to (s), Tables 6.3.1(a) to (j), Table B.6(a), Table B.6(b)

Threads, 5.6.2.4, 5.6.6, A.5.6.6.4

Turns, 7.5.1

Meters, 5.7, A.5.7

Definition, 3.3.65

Leakage check, C.2

Mixing blowers, 7.11.3, 7.11.4, 7.11.5.3, A.7.11.4

Definition, 3.3.66

Multistory installations, 13.2.14 to 13.2.17

-N-

- NA**, 13.1.1(2), 13.2.1(3)
 - Definition, 3.3.67
- NAT Max**, Tables 13.1(a) to (d), 13.1.1(1), 13.1.6, Tables 13.2(a) to (d), 13.2.1(1), 13.2.3(1), 13.2.19
 - Definition, 3.3.68
- NAT+NAT**, Tables 13.2(a) to (d), Table 13.2(f), Table 13.2(g), 13.2.1(2), 13.2.22(3), 13.2.22(4)
 - Definition, 3.3.69
- Natural draft**, *see* Draft(s)
- Natural draft venting systems**, *see* Venting systems
- Noncombustible material**, 4.4, 10.2.4, A.4.4
 - Definition, 3.3.64.2
 - Thimbles, 12.8.4.5
- Nondisplaceable valve member**, 9.6.5, 9.6.6.2
 - Definition, 3.3.100.1
- Notification of interrupted service**, 4.2.1

-O-

- Occupancy**
 - Health care, 10.22.3(2)
 - Definition, 3.3.70.1
 - Residential board and care, 10.22.3(1)
 - Definition, 3.3.70.2
- Offset, vent**, *see* Vent offset
- Open flame decorative appliances, outdoor**, 10.31
- Openings**, *see also* Relief openings
 - Chimneys, 12.6.5.2
 - Combination indoor and outdoor combustion air, 9.3.4, Annex I
 - Indoor combustion air, 9.3.2.3, A.9.3.2.3(1)
 - Outdoor combustion air, 9.3.3, A.9.3.3.1(1) to A.9.3.3.2
 - Pipe, size of, 5.9.9
- Operation of appliances, procedures**, Chap. 11
- Orifices**
 - Definition, 3.3.71
 - Fixed, flow of gas through, Annex E
- Outdoor cooking appliances**, 10.19
 - Definition, 3.3.5.10
- Outdoor open flame decorative appliances**, 10.31
- Outlets**
 - Convenience, *see* Gas convenience outlets
 - Piping, 7.7
- Outside, installation of piping**, 7.2.1; *see also* Underground piping
- Ovens, baking and roasting**, 10.12.1
 - Definition, 3.3.5.5.1
- Overpressure protection devices**, 5.9
 - Piping in vertical chases, 7.4.1
 - Setting, 5.9.6
 - Unauthorized operation, 5.9.7
- Oxygen**
 - As test medium, 8.1.2
 - Use under pressure, 9.1.5

-P-

- Parking structures**
 - Appliances in, 9.1.11.1
 - Basement or underground, 9.1.11.1

- Definition, 3.3.73.1
 - Definition, 3.3.73
 - Enclosed, 9.1.11.1
 - Definition, 3.3.73.2
- Partitions**
 - Piping in, 7.3.3
 - Tubing in, 7.3.4
- Pilot**, 9.1.19, 9.1.20, 9.2.1, 9.7.3, 11.3, G.5.1, G.6.6(5)
 - Definition, 3.3.74
- Pipes and piping**, *see also* Piping systems, gas
 - Aboveground, 7.2, A.7.2.5
 - Bends, 7.5
 - Branch, *see* Branch lines
 - Buildings, in, *see* Buildings, Piping in
 - Bypass, 5.8.6
 - Clearances, underground piping, 7.1.1
 - Concealed
 - In buildings, 7.3
 - Definition, 3.3.76.1
 - Connections, *see* Connections
 - Control piping
 - Definition, 3.3.76.2
 - Overpressure protection devices, 5.9.5
 - Defects, 5.6.5, 8.1.5
 - Definition, 3.3.75, 3.3.76
 - Drips, 7.6
 - Equivalent length (definition), 3.3.75.1
 - Floors, in, 7.3.5
 - Hangers and anchors, 7.2.6
 - Identification, multiple meter installations, 5.7.5
 - Independent, 10.2.1
 - Inspection, testing, and purging, Chap. 8
 - Installation, 5.1.1, Chap. 7, 9.6.9
 - Joining methods, 5.6, A.5.6
 - Materials, 5.6, A.5.6
 - Metallic, *see* Metallic pipe
 - Outlets, 7.7
 - Partitions, in, 7.3.3, 7.3.4
 - Plastic, *see* Plastic pipe
 - Prohibited devices in, 7.9
 - Prohibited locations, 7.2.5, A.7.2.5
 - Protection, underground piping, 7.1.2
 - Protective coating, 5.6.2.5, 5.6.3.5, 7.2.2
 - Sediment traps, 7.6.3, 9.6.8
 - Sizing and capacities of, 5.4.1, 5.4.3, Chap. 6, 9.1.16, A.5.4.1, A.5.4.3, Annex B
 - Equations, 6.4, A.6.4.1, A.6.4.2, B.5, B.6
 - Methods, 6.1, A.6.1, B.4, B.7.1
 - Modification to existing system, B.7.4
 - Overpressure relief devices, 5.9.9
 - Sizing charts, use of, B.7
 - Sloped, 7.2.4
 - Strain on, 9.1.17
 - Supports, *see* Supports, Pipes and piping
 - Turns, 7.5
 - Underground, 7.1, A.7.1.3, A.7.1.4
 - Used materials, 5.6.1.2

- Valves, 7.8
 - In vertical chases, 7.4, A.7.4.3
 - Workmanship, 5.6.5
 - Pipe threads, metallic**, 5.6.2.4, 5.6.6, A.5.6.6.4; *See also* Thread joint compounds
 - Piping systems, gas**, Chap. 5
 - Addition to existing, 5.1.2
 - Bonding and grounding, 7.12, A.7.12.2 to A.7.12.5
 - Definition, 3.3.95.6
 - Design pressure
 - Allowable pressure drop, 5.4.4, B.7.5, B.7.6
 - Maximum, 5.5.1, 5.5.4, A.5.5.4(1)
 - Flexibility, 5.14
 - Gas-air mixtures
 - Flammable, 7.11, A.7.11.4 to A.7.11.6(1)
 - Outside the flammable range, 7.10
 - Interconnections between, 5.3
 - Leakage, *see also* Leak check
 - Emergency procedure for, Annex D
 - Pressure test, 8.1.5.1
 - Local conditions, consideration of, 5.14.2
 - Materials and joining methods, 5.6, A.5.6
 - Operating pressure limitations, 5.5, A.5.5.4(1)
 - Placing in operation, purging for, 8.3.1.2, A.8.3.1.2
 - Plan, 5.1
 - Point of delivery, location of, 5.2
 - Pressure drop, allowable, 5.4.4, B.7.5, B.7.6
 - Pressure testing and inspection, 8.1, A.8.1.1 to A.8.1.4.3
 - Purging, 8.3, A.8.3 to A.8.3.2.1
 - Removal from service, purging for, 8.3.1.1
 - Sizing of, 5.4, 6.2, 6.3, A.5.4.1 to A.5.4.3, Annex B
 - Thermal expansion, 5.14
 - Plastic pipe**, 5.6.4, 5.6.8, A.5.6.4.2
 - Within chimney flue, 12.6.8
 - Connection of, 7.1.7.1, 7.1.7.2
 - Sizing, Tables 6.2(t) to (x), Tables 6.3.1(k) to (m)
 - Tracer wire to locate, 7.1.7.3
 - Turns, 7.5.2
 - Underground, 7.1.7
 - As vent material, 12.5.2, 12.5.3
 - Plenums (definition)**, 3.3.77; *see also* Furnace plenums
 - Point of delivery, location of**, 5.2
 - Pool heaters**, 10.20
 - Definition, 3.3.56.4
 - Power burners**, *see* Burners
 - Pressure**
 - Atmospheric, A.12.1
 - Definition, 3.3.78.1
 - Back
 - Definition, 3.3.78.2
 - Protection, 5.10
 - Definition, 3.3.78
 - Design, *see* Design pressure
 - High pressure gas pipe sizing
 - Formula, 6.4.2, B.5(1)
 - Tables, B.3.5
 - Hybrid pressure pipe sizing method, 6.1.3
 - Low pressure gas pipe sizing
 - Formula for, 6.4.1, B.5(2)
 - Tables, B.3.2
 - Low pressure protection, 5.11, A.5.11
 - Maximum working, 8.1.4.2
 - Definition, 3.3.78.4
 - Operating, limitations on, 5.5, A.5.5.4(1)
 - Pressure drop**
 - Allowable, 5.4.4, B.7.5, B.7.6
 - Definition, 3.3.79
 - Drop per 100 ft pipe sizing method, B.4.4
 - Temperature change, calculating drop due to, B.7.5
 - Pressure limiting devices**, 10.3.4, 10.20.3, 10.27.3
 - Definition, 3.3.28.2
 - Pressure regulators**, *see* Overpressure protection devices; Regulators
 - Pressure relief devices**, 10.3.6, 10.27.5, 11.5, A.10.3.6; *see also* Overpressure protection devices
 - Pressure relief valves**, *see* Relief valves
 - Pressure tests**, 8.1, A.8.1.1 to A.8.1.4.3
 - Primary air**, 11.2, A.11.2
 - Definition, 3.3.2.4
 - Process air**, 9.1.7
 - Protection**, *see also* Corrosion, protection against; Overpressure protection devices
 - Appliances and equipment
 - Floor furnaces, 10.11.10
 - From fumes or gases, 9.1.6, A.9.1.6
 - Open-top broiler units, 10.18.3
 - Outdoor appliances, 9.1.23
 - Physical, 9.1.13
 - Pool heaters, 10.20.1
 - Back pressure, 5.10
 - Control piping, 5.9.4
 - Equipment, 9.1.23
 - Gas pressure regulators, 5.8.4
 - Low-pressure, 5.11, A.5.11
 - Meters, gas, 5.7.4
 - Piping, underground, 7.1.2, 7.1.3, A.7.1.3
 - Protective devices**, 11.5
 - Purge/purging**, 8.3, 10.8.8, 10.9.8, A.8.3 to A.8.3.2.1
 - Definition, 3.3.80
- Q-**
- Qualified agency**, 4.1
 - Definition, 3.3.81
 - Quick-disconnect devices**, 7.7.1.6, 7.7.2.1 Ex. 2, 9.6.6
 - Definition, 3.3.28.3
- R-**
- Radiant appliances**, *see* Decorative appliances for installation in vented fireplaces
 - Ranges**, 12.3.2(1)
 - Household, separation requirements, Fig. A.10.14.1
 - References**, Chap. 2, Annex K
 - Refrigeration systems**
 - Boilers used with, 10.3.9
 - Coils, 10.2.6, 10.3.8, A.10.2.6

- Duct furnaces used with, 10.10.6
- Refrigerators (using gas fuel), 10.21**
 Definition, 3.3.83
 Venting, 12.3.2(6)
- Regulations, gas supplier, 1.1.2**
- Regulators**
 Draft, *see* Draft regulators
 Equipment, 5.8.1, 5.8.5.2
 Monitoring, 5.9.3.1(2)
 Definition, 3.3.84.4, A.3.3.84.4
 Pressure, 1.1.1.1(A), 5.8, 7.4.1, A.1.1.1.1(A), A.5.8; *see also* Gas appliance pressure regulators; Line pressure regulators; Overpressure protection devices
 Definition, 3.3.84.5
 Gas shutoff valves at, 7.8.1
 Pressure testing, 8.1.1.6
 Protection of, 5.8.4
 Series, 5.9.3.1(3)
 Definition, 3.3.84.7
 Service, 1.1.1.1(A), 5.3.1, 5.3.2.1, Table 6.3.1(c), Table 6.3.1(g), Table 6.3.1(i), Table 6.3.1(l), 7.8.2.2, A.1.1.1.1(A)
 Definition, 3.3.84.8
- Regulator vents, 5.6.4.2**
 Definition, 3.3.84.6
- Relief openings**
 Definition, 3.3.85
 Industrial air heaters, 10.8.7, 10.9.7
- Relief valves**
 Definition, 3.3.99.5
 Pressure relief
 Definition, 3.3.99.5.1
 For steam and hot water boilers, 10.3.6, A.10.3.6
 Temperature relief, 10.27.5
 Definition, 3.3.99.5.2
 Vacuum relief, 10.27.5
 Definition, 3.3.99.5.3
- Repairs**
 Gas shutoff prior to, 4.2.2
 Pressure testing after, 8.1.1.3
- Residential board and care occupancy, 10.22.3(1)**
 Definition, 3.3.70.2
- Retroactivity of code, 1.3**
- Risers**
 Anodeless, 5.6.4.3
 Definition, 3.3.4
 Corrosion, protection against, 7.3.5.2
- Roofs**
 Appliances on, 9.4
 Piping on, 7.2.6.4
- Room heaters, 10.22, A.10.22.1**
 Institutions, installations in, 10.22.3
 Prohibited installations, 10.22.1, A.10.22.1
 Unvented, 10.22.1, 10.22.2, 12.3.2(8), A.10.22.1
 Definition, 3.3.56.6
 Wall, 10.22.5
- Definition, 3.3.86
- Safety inspection, existing appliance installation, Annex G**
- Safety shutoff devices, 10.4.6, 11.3; *see also* Automatic gas shutoff devices; Valves**
 Definition, 3.3.28.4
 Unlisted LP-gas equipment used indoors, 9.1.4
- Scope of code, 1.1, A.1.1.1.1(A)**
- Screens, 9.3.7**
- Seepage pan, 10.11.9**
- Separate users, interconnections between, 5.3.1**
- Service head adapters, 5.6.4.3(2)**
 Definition, 3.3.87
- Service meter assembly, 1.1.1.1(A), A.1.1.1.1(A)**
 Definition, 3.3.88
- Service regulators, *see* Regulators**
- Service shutoff valves, *see* Valves**
- Shall (definition), 3.2.6**
- Shutoff procedure, 4.2.1; *see also* Safety shutoff devices; Valves**
- Shutoff valves, *see* Valves**
- Sources of ignition, 4.3.1**
 Definition, 3.3.59.2
- Spaces**
 Surrounding chimney lining or vent, 12.6.8
 Well-ventilated, 12.3.4
- Specific gravity**
 Definition, 3.3.91
 Sizing of gas pipe and, B.3.4
- Standby fuels, interconnections for, 5.3.2**
- Steam cooker, 10.12.1**
 Definition, 3.3.5.5.5
- Steam generator, 10.12.1**
 Definition, 3.3.5.5.6
- Steam safety valves, 10.3.6, A.10.3.6**
- Stress**
 Definition, 3.3.94
 Hoop, 8.1.4.2
 Definition, 3.3.94.1
- Supports**
 Chimneys, 12.6.6
 Equipment, 9.1.8
 Floor furnaces, 10.11.6
 Gas vents, 12.7.6
 Heaters
 Infrared, 10.17.1
 Unit, 10.25.1
 Meters, gas, 5.7.3
 Pipes and piping, 5.14.2, 7.2.1, 7.2.6, 12.8.6
 Vent connectors, 12.11.9
- Suspended low-intensity infrared tube heaters, 9.6.1.5, A.9.6.1.5**
- Suspended-type unit heaters, 10.25.2.1**
- Switches, electrical supply line, 10.2.7**
- Systems, *see also* Central premix system; Hybrid pressure system; Mechanical exhaust systems; Piping systems, gas; Venting systems**
 Fan-assisted combustion system (definition), 3.3.95.2; *see also* Fan-assisted combustion appliances

-S-

Safety blowouts (backfire preventers), 7.11.1(4), 7.11.6, A.7.11.6(1)

-T-

Temperature change, calculating pressure drop due to, B.7.5

Temperature limit controls/devices, 10.3.4

Floor furnaces, 10.11.2

Pool heaters, 10.20.3

Water heaters, 10.27.4

Temperature relief valves, 10.27.5

Definition, 3.3.99.5.2

Tensile strength

Definition, 3.3.96

Plastic piping material, 5.6.8(1)

Termination, venting systems, *see* Venting systems

Testing, piping system

Defects, pressure test for, 8.1.5.1

Leakage

Pressure test for detection, 8.1.5.1

System leak check, 8.2, A.8.2.3

Pressure, 8.1, A.8.1.1 to A.8.1.4.3

Thermostats, room temperature, 9.8

Thimbles, 12.8.4.5, 12.8.4.6, 12.11.10

Thread joint compounds, 5.6.6.4, A.5.6.6.4

Definition, 3.3.97

Toilets, gas-fired, 10.24, Table 12.5.1

Traps, sediment, 7.6.3, 9.6.8

Trenches, 7.1.2.2

Tubing

Appliances and equipment connections, 9.6.1(2)

Bonding and grounding, 7.12, A.7.12.2 to A.7.12.5

Corrosion protection, 7.1.3, A.7.1.3

Definition, 3.3.98

Low pressure gas pipe sizing tables, B.3.2

Metallic, 5.6.3, 5.6.7.2, 5.6.7.3, A.5.6.3.4, B.7.3

Partitions, in, 7.3.4

Plastic, 5.6.4, 5.6.8, A.5.6.4.2

Sizing and capacities of, Tables 6.2(i) to (t), Table 6.2(w), Table 6.2(x), Tables 6.3.1(e) to (j), Table 6.3.1(m), B.6, B.7.3

Workmanship and defects, 5.6.5

Type B gas vents, *see* Gas vents

Type B-W gas vents, *see* Gas vents

Type L vents, *see* Gas vents

-U-

Underground piping, 7.1, A.7.1.3, A.7.1.4

Unit broilers, *see* Broilers

Unit heaters, 10.25

Definition, 3.3.56.5

Utility gases

Definition, 3.3.49.2

Fixed orifices, flow of gas through, Annex E

-V-

Vacuum relief valves, 10.27.5

Definition, 3.3.99.5.3

Valve members

Definition, 3.3.100

Nondisplaceable, 9.6.5, 9.6.6.2

Definition, 3.3.100.1

Valves

Accessibility of, 7.8.1, 7.8.2.1, 7.8.2.2

Appliance shutoff, 5.12, 7.7.2.2, 9.6.5, 12.6.5.2

Definition, 3.3.99.1

Gas-mixing machines, 7.11.5.4, A.7.11.5.4

Manual, 7.8, 9.6.5

Automatic, 5.13, 9.7.3

Definition, 3.3.99.2

Bypass

Gas line pressure regulators, 5.8.6

Pool heaters, 10.20.4

Controlling multiple systems, 7.8.2

Definition, 3.3.99

Diaphragm type, bleed lines for, 9.1.20

Excess flow valve (EFV), 5.13

Definition, 3.3.99.3

Manual main gas control, 7.8.2.1

Manual reset, 7.11.5.4, A.7.11.5.4

Definition, 3.3.99.4

Mixing blowers, 7.11.4, A.7.11.4

Pressure testing, 8.1.1.6

Relief, *see* Relief valves

Service shutoff, 5.12

Definition, 3.3.99.6

Emergency, 7.8.2.3

Laboratories, 7.8.2.4

Manual, 7.8

For multiple systems, 7.8.2

Tubing systems, 7.3.6

Steam safety, 10.3.6, A.10.3.6

Used, 5.6.1.2

Vapors, flammable, appliances in area of, 9.1.9

Vehicular fuel systems, compressed natural gas, 10.28

Vent(s)

Gas, *see* Gas vents

Heater, 10.8.6, 10.9.6

Obstructions, 12.16, 13.1.1

Overpressure protection devices, 5.9.8

Regulator, 5.6.4.2

Sizes, 12.7.4, A.12.7.4.1

Appliance categorized vent diameter/area, *see* Appliance categorized vent diameter/area

Multiple appliance vents, 13.2, A.13.2.20

Single appliance vents, 13.1, A.13.1.7

Toilets, gas-fired, 10.24.3

Vent connectors, 12.11, 12.12, A.12.11.3, A.12.11.8

Chimneys, *see* Chimneys

Clearance, 12.11.5

Dampers, 12.14

Definition, 3.3.101

Fireplaces, 12.11.12

Inspection, 12.11.11

Joints, 12.11.6

Length, 12.11.8, A.12.11.8

Location, 12.11.10

Materials, 12.11.2

- Maximum length, 13.2.2, 13.2.3
 - Mechanical draft systems, 12.4.3.4
 - Obstructions, 12.16
 - Routing, 13.2.3
 - Size of, 12.11.3, 13.1.12, 13.1.13, 13.2.4, 13.2.8, A.12.11.3
 - Slope, 12.11.7
 - Support, 12.11.9
 - Through ceilings, floors, or walls, 12.11.13
 - Toilets, gas-fired, 10.24.3
 - Two or more appliances, 12.11.3.3 to 12.11.3.6, 12.11.4
 - Vent dampers, automatic**, *see* Automatic vent dampers
 - Vented appliances**, Chap. 12
 - Category I, Table 12.5.1, 12.6.1.3 Ex., 12.6.3.1, 12.7.4.1, 12.9.4, 12.10.2, 12.11, Chap. 13, A.12.7.4.1, A.12.11.3, A.12.11.8, Annex F
 - Definition, 3.3.5.11.1, A.3.3.5.11.1
 - Category II, Table 12.5.1, 12.7.4.3, 12.9.4, 12.10.1, 12.12
 - Definition, 3.3.5.11.2
 - Category III, Table 12.5.1, 12.7.4.3, 12.9.4, 12.10.2, 12.12
 - Definition, 3.3.5.11.3
 - Category IV, Table 12.5.1, 12.7.4.3, 12.9.4, 12.9.6, 12.10.1, 12.12
 - Definition, 3.3.5.11.4
 - Vented wall furnaces**, *see* Furnaces
 - Vent gases (definition)**, 3.3.49.3
 - Ventilating hoods**, 10.18.3, 12.3.3, 12.4.4, 12.7.3(1)(g), A.12.3.3, A.12.4.4
 - Ventilation**
 - Air for, 9.3, A.9.3, Annex I
 - Chase, 7.4.3, A.7.4.3
 - Equipment, 9.1.2(1)
 - Food service appliances, 10.12.8, A.10.12.8
 - Industrial air heaters, 10.8.3.3, 10.8.5, 10.9.5
 - Infrared heaters, 10.17.3
 - Open-top broiler units, 10.18.3, 10.18.4
 - Venting**, Chap. 12
 - Definition, 3.3.103
 - Equipment not requiring venting, 12.3.2
 - Flue gases, 9.1.14
 - Pressure regulators, 5.8.5, 7.4.1, 9.1.19
 - Venting systems**
 - Appliances, 9.1.14
 - Connection to, *see* Vent connectors
 - Definition, 3.3.95.7, A.3.3.95.7
 - Design and construction, 12.4, A.12.4.4
 - Equipment, 9.1.2(3)
 - Mechanical draft, 12.4.3, 12.6.3.1(4), 12.7.4.4
 - Definition, 3.3.95.7.2
 - Forced, 12.4.3.2, 12.4.3.3, 12.7.3(7), 12.9.1, 12.13.1 Ex.
 - Forced (definition), 3.3.95.7.1
 - Termination, 12.4.3.6, 12.7.3(1)(f), 12.9.1, 12.9.2, Fig. A.12.9
 - Vent connectors, 12.4.3.4, 12.11.4.3, 12.11.7 Ex.
 - Natural draft
 - Definition, 3.3.95.5
 - Sizing of, 12.7.4.1, A.12.7.4.1
 - Testing, G.5.2
 - Pool heaters, 10.20.5
 - Refrigerators, 10.21.2
 - Sizing of
 - Appliances equipped with draft hoods or listed for use with Type B vent, Annex F
 - Category I appliances, 12.6.3.1, 12.7.4.1, 12.7.4.2, Chap. 13, A.12.7.4.1, Annex F
 - Category II, III, and IV appliances, 12.7.4.3
 - Chimney venting, 12.6.3.1, 12.7.4.4
 - Specification for, 12.3, A.12.3.3
 - Termination
 - Chimneys, 12.6.2, A.12.6.2.1
 - Gas vents, 12.7.3
 - Mechanical draft systems, 12.4.3.6
 - Single-wall metal pipe, 12.8.3
 - Through the wall, 12.9, A.12.9
 - Two or more appliances, single vent, 12.11.3.3 to 12.11.3.6, 12.11.4, 13.2.18
 - Type of system to use, 12.5, Table 12.5.1
 - Vented appliances, *see* Vented appliances
 - Vent offset (definition), 3.3.102
 - Vent offset**, 12.7.4.2, 13.1.3, 13.1.7, 13.2.5, 13.2.17, 13.2.20, A.13.2.20, Fig. F.1(1)
 - Definition, 3.3.102
- W-**
- Wall furnaces**, *see* Furnaces
 - Wall head adapters**, 7.1.7.1 Ex.2
 - Definition, 3.3.104
 - Wall room heaters**, 10.22.5
 - Water heaters**, 10.27, A.10.27.7
 - Antisiphon devices, 10.27.7, A.10.27.7
 - Automatic instantaneous type, 10.27.6
 - Circulating tank type, 10.27.7, A.10.27.7
 - Definition, 3.3.56.7
 - Venting, 12.3.2(5), 13.1.11(5), F.2.1 to F.2.4
 - Weather conditions**, 5.14.2
 - Floor furnaces and, 10.11.10
 - Lightning protection, 7.12.5, A.7.12.5
 - Protection against, 7.1.4, A.7.1.4
 - Single-wall metal pipe, use of, 12.8.2, A.12.8.2
 - Work interruptions**, 4.2.2
- Z-**
- Zero governor**, 7.11.4
 - Definition, 3.3.105