

NFPA[®]

111

**Standard on
Stored Electrical Energy
Emergency and Standby
Power Systems**

2019



IMPORTANT NOTICES AND DISCLAIMERS CONCERNING NFPA® STANDARDS

NOTICE AND DISCLAIMER OF LIABILITY CONCERNING THE USE OF NFPA STANDARDS

NFPA® codes, standards, recommended practices, and guides (“NFPA Standards”), of which the document contained herein is one, are developed through a consensus standards development process approved by the American National Standards Institute. This process brings together volunteers representing varied viewpoints and interests to achieve consensus on fire and other safety issues. While the NFPA administers the process and establishes rules to promote fairness in the development of consensus, it does not independently test, evaluate, or verify the accuracy of any information or the soundness of any judgments contained in NFPA Standards.

The NFPA disclaims liability for any personal injury, property, or other damages of any nature whatsoever, whether special, indirect, consequential or compensatory, directly or indirectly resulting from the publication, use of, or reliance on NFPA Standards. The NFPA also makes no guaranty or warranty as to the accuracy or completeness of any information published herein.

In issuing and making NFPA Standards available, the NFPA is not undertaking to render professional or other services for or on behalf of any person or entity. Nor is the NFPA undertaking to perform any duty owed by any person or entity to someone else. Anyone using this document should rely on his or her own independent judgment or, as appropriate, seek the advice of a competent professional in determining the exercise of reasonable care in any given circumstances.

The NFPA has no power, nor does it undertake, to police or enforce compliance with the contents of NFPA Standards. Nor does the NFPA list, certify, test, or inspect products, designs, or installations for compliance with this document. Any certification or other statement of compliance with the requirements of this document shall not be attributable to the NFPA and is solely the responsibility of the certifier or maker of the statement.

REVISION SYMBOLS IDENTIFYING CHANGES FROM THE PREVIOUS EDITION

Text revisions are shaded. A **Δ** before a section number indicates that words within that section were deleted and a **Δ** to the left of a table or figure number indicates a revision to an existing table or figure. When a chapter was heavily revised, the entire chapter is marked throughout with the **Δ** symbol. Where one or more sections were deleted, a **•** is placed between the remaining sections. Chapters, annexes, sections, figures, and tables that are new are indicated with an **N**.

Note that these indicators are a guide. Rearrangement of sections may not be captured in the markup, but users can view complete revision details in the First and Second Draft Reports located in the archived revision information section of each code at www.nfpa.org/docinfo. Any subsequent changes from the NFPA Technical Meeting, Tentative Interim Amendments, and Errata are also located there.

REMINDER: UPDATING OF NFPA STANDARDS

Users of NFPA codes, standards, recommended practices, and guides (“NFPA Standards”) should be aware that NFPA Standards may be amended from time to time through the issuance of a Tentative Interim Amendment (TIA) or corrected by Errata. An official NFPA Standard at any point in time consists of the current edition of the document together with any TIAs and Errata then in effect.

To determine whether an NFPA Standard has been amended through the issuance of Tentative Interim Amendments or corrected by Errata, go to www.nfpa.org/docinfo to choose from the list of NFPA Standards or use the search feature to select the NFPA Standard number (e.g., NFPA 13). The document information page provides up-to-date document-specific information as well as postings of all existing TIAs and Errata. It also includes the option to register for an “Alert” feature to receive an automatic email notification when new updates and other information are posted regarding the document.

IMPORTANT NOTICES AND DISCLAIMERS CONCERNING NFPA® STANDARDS

ADDITIONAL NOTICES AND DISCLAIMERS

Updating of NFPA Standards

Users of NFPA codes, standards, recommended practices, and guides (“NFPA Standards”) should be aware that these documents may be superseded at any time by the issuance of new editions or may be amended from time to time through the issuance of Tentative Interim Amendments or corrected by Errata. An official NFPA Standard at any point in time consists of the current edition of the document together with any Tentative Interim Amendments and any Errata then in effect. In order to determine whether a given document is the current edition and whether it has been amended through the issuance of Tentative Interim Amendments or corrected through the issuance of Errata, consult appropriate NFPA publications such as the National Fire Codes® Subscription Service, visit the NFPA website at www.nfpa.org, or contact the NFPA at the address listed below.

Interpretations of NFPA Standards

A statement, written or oral, that is not processed in accordance with Section 6 of the Regulations Governing the Development of NFPA Standards shall not be considered the official position of NFPA or any of its Committees and shall not be considered to be, nor be relied upon as, a Formal Interpretation.

Patents

The NFPA does not take any position with respect to the validity of any patent rights referenced in, related to, or asserted in connection with an NFPA Standard. The users of NFPA Standards bear the sole responsibility for determining the validity of any such patent rights, as well as the risk of infringement of such rights, and the NFPA disclaims liability for the infringement of any patent resulting from the use of or reliance on NFPA Standards.

NFPA adheres to the policy of the American National Standards Institute (ANSI) regarding the inclusion of patents in American National Standards (“the ANSI Patent Policy”), and hereby gives the following notice pursuant to that policy:

NOTICE: The user’s attention is called to the possibility that compliance with an NFPA Standard may require use of an invention covered by patent rights. NFPA takes no position as to the validity of any such patent rights or as to whether such patent rights constitute or include essential patent claims under the ANSI Patent Policy. If, in connection with the ANSI Patent Policy, a patent holder has filed a statement of willingness to grant licenses under these rights on reasonable and nondiscriminatory terms and conditions to applicants desiring to obtain such a license, copies of such filed statements can be obtained, on request, from NFPA. For further information, contact the NFPA at the address listed below.

Law and Regulations

Users of NFPA Standards should consult applicable federal, state, and local laws and regulations. NFPA does not, by the publication of its codes, standards, recommended practices, and guides, intend to urge action that is not in compliance with applicable laws, and these documents may not be construed as doing so.

Copyrights

NFPA Standards are copyrighted. They are made available for a wide variety of both public and private uses. These include both use, by reference, in laws and regulations, and use in private self-regulation, standardization, and the promotion of safe practices and methods. By making these documents available for use and adoption by public authorities and private users, the NFPA does not waive any rights in copyright to these documents.

Use of NFPA Standards for regulatory purposes should be accomplished through adoption by reference. The term “adoption by reference” means the citing of title, edition, and publishing information only. Any deletions, additions, and changes desired by the adopting authority should be noted separately in the adopting instrument. In order to assist NFPA in following the uses made of its documents, adopting authorities are requested to notify the NFPA (Attention: Secretary, Standards Council) in writing of such use. For technical assistance and questions concerning adoption of NFPA Standards, contact NFPA at the address below.

For Further Information

All questions or other communications relating to NFPA Standards and all requests for information on NFPA procedures governing its codes and standards development process, including information on the procedures for requesting Formal Interpretations, for proposing Tentative Interim Amendments, and for proposing revisions to NFPA standards during regular revision cycles, should be sent to NFPA headquarters, addressed to the attention of the Secretary, Standards Council, NFPA, 1 Batterymarch Park, P.O. Box 9101, Quincy, MA 02269-9101; email: stds_admin@nfpa.org.

For more information about NFPA, visit the NFPA website at www.nfpa.org. All NFPA codes and standards can be viewed at no cost at www.nfpa.org/docinfo.

Copyright © 2018 National Fire Protection Association®. All Rights Reserved.

NFPA® 111

Standard on

Stored Electrical Energy Emergency and Standby Power Systems

2019 Edition

This edition of NFPA 111, *Standard on Stored Electrical Energy Emergency and Standby Power Systems*, was prepared by the Technical Committee on Emergency Power Supplies and released by the Correlating Committee on National Electrical Code®. It was issued by the Standards Council on December 24, 2017, with an effective date of January 13, 2018, and supersedes all previous editions.

This edition of NFPA 111 was approved as an American National Standard on January 13, 2018.

Origin and Development of NFPA 111

The Technical Committee on Emergency Power Supplies was organized in 1976 by NFPA in recognition of the demand for guidelines on the assembly, installation, and performance of electrical power systems to supply critical and essential needs during outages of the normal power source. During the development of a base standard (NFPA 110, *Standard for Emergency and Standby Power Systems*), it was determined that several power sources were available for emergency and standby power systems. The committee determined that sufficient differences existed between these sources to justify separate documents providing clearly defined specifics. Each document would follow the basic format of NFPA 110 to provide a consistent basis for comparison and usage and would remain under the jurisdiction of the Technical Committee on Emergency Power Supplies.

Because of the unique knowledge necessary to provide an authoritative document, the technical committee authorized a subcommittee in 1982 to prepare a draft document on systems using stored energy sources. In 1986, a document tentatively titled NFPA 110A, *Stored Energy Emergency and Standby Power Systems*, was submitted for adoption at the 1989 NFPA Annual Meeting.

Formally designated as NFPA 111, this document addressed the performance of stored energy systems with appropriate equipment detail. The requirements of the standard were considered necessary to obtain the minimum level of reliability and performance and to achieve an on-site stored energy auxiliary electrical power source suitable to the needs of the applicable requirements. If followed, its use would result in a system suitable for various situations as required by other codes and standards.

The second edition in 1993 contained only minor changes.

For the 1996 edition, a section was added to cover the acceptability of systems, methods, and devices other than those listed in the document.

The 2001 edition contained two changes: informational text was moved to the appendix, and the operational testing requirements were expanded.

The 2005 edition underwent a complete rewrite in accordance with the *Manual of Style for NFPA Technical Committee Documents*. Along with the rewrite, some of the definitions were revised and located in Chapter 3. Other data in the document were transferred to the table format for better usability.

The 2010 edition revised the document scope to clarify that an uninterruptible power supply (UPS) supplied through an emergency power supply (EPS) is not a stored emergency power supply system (SEPS). The definitions of *automatic transfer switch* and *nonautomatic transfer switch* were revised to correlate with NFPA 110. New definitions covered battery cell types, bridging systems, and electrochemical energy storage devices. Energy sources, convertors, inverters, and accessories were covered by Chapter 5 revisions that clarified existing requirements, recognized new battery types, and provided requirements covering stored energy sources other than batteries. Revisions to area ventilation requirements acknowledged that there might be flammable gases other than hydrogen

associated with energy sources that are not batteries. Annex diagrams were added to illustrate flywheel and rotating EPS systems, different UPS systems, and basic switching points of an SEPSS.

A rectifier plant, which is often used in the telecommunications industry, was added in the 2013 edition as a potential stored emergency power supply system (SEPSS). These rectifier plants were also included as a suitable bridging system. The location of SEPSS equipment serving Level 1 EPSS loads was revised to correlate with the requirements of NFPA 110.

Throughout the 2016 edition, references to a *stored emergency power supply system* were revised to a *stored-energy emergency power supply system* to more appropriately describe the type of system. Requirements for baseline measurements were revised to provide more accurate data. The load test was revised to correlate with the IEEE 450 rate-adjusted and time-adjusted capacity tests.

In the 2019 edition, Table 4.2.2 has been revised to cover the interruption time without reference to specific SEPSS types.

Correlating Committee on National Electrical Code®

Michael J. Johnston, *Chair*
National Electrical Contractors Association, MD [IM]

Mark W. Earley, *Secretary (Nonvoting)*
National Fire Protection Association, MA

James E. Brunssen, Telcordia Technologies (Ericsson), NJ [UT]
Rep. Alliance for Telecommunications Industry Solutions

Kevin L. Dressman, U.S. Department of Energy, MD [U]

Palmer L. Hickman, Electrical Training Alliance, MD [L]
Rep. International Brotherhood of Electrical Workers

David L. Hittinger, Independent Electrical Contractors of Greater Cincinnati, OH [IM]
Rep. Independent Electrical Contractors, Inc.

Richard A. Holub, The DuPont Company, Inc., DE [U]
Rep. American Chemistry Council

John R. Kovacik, UL LLC, IL [RT]

Alan Manche, Schneider Electric, KY [M]

Roger D. McDaniel, Georgia Power Company, GA [UT]
Rep. Electric Light & Power Group/EEI

James F. Pierce, Intertek Testing Services, OR [RT]

Vincent J. Saporita, Eaton's Bussmann Business, MO [M]
Rep. National Electrical Manufacturers Association

David A. Williams, Delta Charter Township, MI [E]
Rep. International Association of Electrical Inspectors

Alternates

Lawrence S. Ayer, Biz Com Electric, Inc., OH [IM]
(Alt. to David L. Hittinger)

Roland E. Deike, Jr., CenterPoint Energy, Inc., TX [UT]
(Alt. to Roger D. McDaniel)

James T. Dollard, Jr., IBEW Local Union 98, PA [L]
(Alt. to Palmer L. Hickman)

Ernest J. Gallo, Telcordia Technologies (Ericsson), NJ [UT]
(Alt. to James E. Brunssen)

Robert A. McCullough, Tuckerton, NJ [E]
(Alt. to David A. Williams)

Robert D. Osborne, UL LLC, NC [RT]
(Alt. to John R. Kovacik)

Christine T. Porter, Intertek Testing Services, WA [RT]
(Alt. to James F. Pierce)

George A. Straniero, AFC Cable Systems, Inc., NJ [M]
(Alt. to Vincent J. Saporita)

Nonvoting

Timothy J. Pope, Canadian Standards Association, Canada [SE]
Rep. CSA/Canadian Electrical Code Committee

William R. Drake, Fairfield, CA [M]
(Member Emeritus)

D. Harold Ware, Libra Electric Company, OK [IM]
(Member Emeritus)

Mark W. Earley, NFPA Staff Liaison

This list represents the membership at the time the Committee was balloted on the final text of this edition. Since that time, changes in the membership may have occurred. A key to classifications is found at the back of the document.

NOTE: Membership on a committee shall not in and of itself constitute an endorsement of the Association or any document developed by the committee on which the member serves.

Committee Scope: This Committee shall have primary responsibility for documents on minimizing the risk of electricity as a source of electric shock and as a potential ignition source of fires and explosions. It shall also be responsible for text to minimize the propagation of fire and explosions due to electrical installations.

Technical Committee on Emergency Power Supplies

Dan Chisholm, Sr., Chair
MGI Systems, Inc., FL [IM]

Ernest E. Allen, The Doctors Company, OH [I]
Rep. NFPA Health Care Section

Kenneth A. Cotton, U.S. Energy/Donlee Crop, CA [M]

Jason D'Antona, Thompson Consultants, Inc., MA [SE]

David A. Dagenais, Partners/Wentworth-Douglass Hospital, NH [U]

Richard L. Day, Michigan State Fire Marshal's Office, MI [E]

Dennis DeMoss, Sargent & Lundy, IL [SE]

William H. Everard, Everard Mid Atlantic, Inc., VA [SE]

Louis J. Feller, U.S. Army Corps of Engineers, WA [U]

James R. (Skip) Gregory, Health Facility Consulting, FL [E]
Rep. Florida Agency for Health Care Administration

Ross M. Hardy, The University of Michigan Medical Center, MI [U]

Jonathan Hartsell, Rodgers, NC [IM]

Oleh Kowalskyj, U.S. Department of Veterans Affairs, DC [U]
Rep. U.S. Department of Veterans Affairs

Pouyan Layegh, University of Texas MD Anderson Cancer Center,
TX [U]

Chad E. Loomis, Cornell University, NY [U]

Alan Manche, Schneider Electric, KY [M]

George Mills, The Joint Commission Department of Engineering,
IL [E]

Rep. Joint Commission on Accreditation Healthcare
Organizations

Dermott Murphy, Washington State Patrol - Fire Prevention Bureau,
WA [E]

Hugh O. Nash, Jr., Nash-Consult, TN [SE]

Daniel J. O'Connor, JENSEN HUGHES/AON Fire Protection
Engineering, IL [I]

Gary L. Olson, kW Rx, LLC, MN [SE]

Steve R. Sappington, Caterpillar Inc., GA [M]

Ronald A. Schroeder, ASCO Power Technologies, LP, NJ [M]

Randy H. Schubert, Ericsson, NJ [U]

Rep. Alliance for Telecommunications Industry Solutions

Ronald M. Smidt, Carolinas HealthCare System, NC [U]

Rep. American Society for Healthcare Engineering

Raymond J. Stanko, UL LLC, IL [RT]

David Stymiest, Smith Seckman Reid, Inc., TN [SE]

Herbert V. Whittall, Electrical Generating Systems Association, FL
[M]

Timothy P. Windey, Cummins Power Generation, MN [M]

Stephen Works, Blanchard Machinery, SC [IM]

Alternates

Raymond J. Battalora, JENSEN HUGHES/AON Fire Protection
Engineering, TX [I]
(Alt. to Daniel J. O'Connor)

Dan Chisholm, Jr., MGI Systems, Inc., FL [IM]
(Alt. to Dan Chisholm, Sr.)

Joshua Dugger, Facility Shield International, CA [M]
(Alt. to Kenneth A. Cotton)

Brian J. Escott, ASCO Power Technologies, NJ [M]
(Alt. to Ronald A. Schroeder)

James Hunt, Hostrat Inc., WA [M]
(Alt. to Herbert V. Whittall)

Richard G. Kluge, Ericsson, NJ [U]
(Alt. to Randy H. Schubert)

Christopher Coache, NFPA Staff Liaison

Gary Krauch, Virginia New England Healthcare System, MA [U]
(Alt. to Oleh Kowalskyj)

Michael J. Lang, Mersen, GA [M]
(Voting Alt.)

Rich Scroggins, Cummins Power Generation, MN [M]
(Voting Alt.)

David C. Skiba, Sargent & Lundy LLC, IL [SE]
(Alt. to Dennis DeMoss)

Bogue M. Waller, Gresham Smith & Partners, TN [SE]
(Alt. to Hugh O. Nash, Jr.)

This list represents the membership at the time the Committee was balloted on the final text of this edition. Since that time, changes in the membership may have occurred. A key to classifications is found at the back of the document.

NOTE: Membership on a committee shall not in and of itself constitute an endorsement of the Association or any document developed by the committee on which the member serves.

Committee Scope: This Committee shall have primary responsibility for documents on performance criteria for the selection and assembly of the components for emergency and standby power systems in buildings and facilities, including categories of power supplies, transfer equipment, controls, supervisory equipment, and all related electrical and mechanical auxiliary or accessory equipment needed to supply emergency or standby power to the utilization equipment. The Committee also shall be responsible for criteria on the maintenance and testing of the system. This Committee does not cover requirements for the application of emergency power systems, self-contained emergency lighting units, and electrical wiring, except that wiring that is an integral part of the system up to the load side of the transfer switch(es). This Committee shall report to Correlating Committee of the National Electrical Code.

Contents

Chapter 1 Administration	111- 6	Chapter 6 Transfer Switches and Protection	111- 10
1.1 Scope.	111- 6	6.1 General.	111- 10
1.2 Purpose.	111- 6	6.2 Transfer Switches.	111- 10
1.3 Application.	111- 6	6.3 Load Switching (Load Shedding).	111- 11
1.4 Equivalency.	111- 6	6.4 Bypass Switches.	111- 11
1.5 Function.	111- 7	6.5 Protection.	111- 12
Chapter 2 Referenced Publications	111- 7	Chapter 7 Installation and Environmental	
2.1 General.	111- 7	Considerations	111- 12
2.2 NFPA Publications.	111- 7	7.1 General.	111- 12
2.3 Other Publications.	111- 7	7.2 Location.	111- 12
2.4 References for Extracts in Mandatory Sections.	111- 7	7.3 Heating, Cooling, Ventilating, and Humidity	
Chapter 3 Definitions	111- 7	Control.	111- 12
3.1 General.	111- 7	7.4 Protection.	111- 12
3.2 NFPA Official Definitions.	111- 7	7.5 Distribution.	111- 13
3.3 General Definitions.	111- 7	7.6 Installation Acceptance.	111- 13
Chapter 4 Classification of Stored-Energy		Chapter 8 Routine Maintenance and Operational	
Emergency Power Supply Systems		Testing	111- 13
(SEPSS)	111- 8	8.1 General.	111- 13
4.1 General.	111- 8	8.2 Manuals, Special Tools, and Spare Parts.	111- 14
4.2 Type.	111- 8	8.3 Maintenance and Operational Testing.	111- 14
4.3 Class.	111- 8	8.4 Operational Inspection and Testing.	111- 14
4.4 Category.	111- 8	Annex A Explanatory Material	111- 14
4.5 Level.	111- 8	Annex B Diagram of SEPSS Versus EPSS Use of	
Chapter 5 Emergency Power Supply: Energy		Stored-Energy System	111- 20
Sources, Convertors, Inverters, and		Annex C Informational References	111- 23
Accessories	111- 9	Index	111- 25
5.1 Energy Sources.	111- 9		
5.2 Energy Conversion Equipment (ECE) —			
General.	111- 9		
5.3 Instrumentation.	111- 9		

NFPA 111

Standard on

Stored Electrical Energy Emergency and Standby Power Systems

2019 Edition

IMPORTANT NOTE: This NFPA document is made available for use subject to important notices and legal disclaimers. These notices and disclaimers appear in all publications containing this document and may be found under the heading “Important Notices and Disclaimers Concerning NFPA Standards.” They can also be viewed at www.nfpa.org/disclaimers or obtained on request from NFPA.

UPDATES, ALERTS, AND FUTURE EDITIONS: New editions of NFPA codes, standards, recommended practices, and guides (i.e., NFPA Standards) are released on scheduled revision cycles. This edition may be superseded by a later one, or it may be amended outside of its scheduled revision cycle through the issuance of Tentative Interim Amendments (TIAs). An official NFPA Standard at any point in time consists of the current edition of the document, together with all TIAs and Errata in effect. To verify that this document is the current edition or to determine if it has been amended by TIAs or Errata, please consult the National Fire Codes® Subscription Service or the “List of NFPA Codes & Standards” at www.nfpa.org/docinfo. In addition to TIAs and Errata, the document information pages also include the option to sign up for alerts for individual documents and to be involved in the development of the next edition.

NOTICE: An asterisk (*) following the number or letter designating a paragraph indicates that explanatory material on the paragraph can be found in Annex A.

A reference in brackets [] following a section or paragraph indicates material that has been extracted from another NFPA document. As an aid to the user, the complete title and edition of the source documents for extracts in mandatory sections of the document are given in Chapter 2 and those for extracts in informational sections are given in Annex C. Extracted text may be edited for consistency and style and may include the revision of internal paragraph references and other references as appropriate. Requests for interpretations or revisions of extracted text shall be sent to the technical committee responsible for the source document.

Information on referenced publications can be found in Chapter 2 and Annex C.

Chapter 1 Administration

1.1 Scope.

1.1.1* This standard shall cover performance requirements for stored electrical energy systems providing an alternate source of electrical power in buildings and facilities in the event that the normal electrical power source fails.

1.1.2 Systems covered in this standard shall include power sources, transfer equipment, controls, supervisory equipment, and accessory equipment, including integral accessory equipment, needed to supply electrical power to the selected circuits.

1.1.3 This standard shall cover installation, maintenance, operation, and testing requirements as they pertain to the performance of the stored-energy emergency power supply system (SEPSS).

1.1.4 Exclusions.

1.1.4.1* This standard shall not cover the following:

- (1) Application of the SEPSS
- (2) Distribution wiring
- (3) Systems having total outputs less than 500 VA or less than 24 V or systems less than Class 0.033 in accordance with Section 4.3
- (4) Unit equipment
- (5) Nuclear sources, solar systems, and wind stored-energy systems
- (6) Uninterruptible power systems (UPS) supplied by an emergency power supply system (EPSS) or a UPS supplied by an SEPSS
- (7) Optional standby systems

1.1.4.2 The following shall not be within the scope of this standard:

- (1) Specific buildings or facilities, or both, requiring an SEPSS
- (2) Specific loads to be served by the SEPSS
- (3) Type, class, or level to be assigned to any specific load (See Section 4.1.)

1.2 Purpose.

1.2.1 This standard shall provide performance requirements for SEPSS and also shall be used in conjunction with other standards.

1.2.2 It shall be the role of other NFPA standards to specify which occupancies require an SEPSS and the applicable level, type, and class.

1.2.3 This standard shall not specify where an SEPSS is required. (See 1.1.4.2.)

1.2.4 This standard shall provide guidance for inspectors, designers, installers, manufacturers, and users of an SEPSS and shall serve as a basis for communication between the parties involved.

1.2.5 This standard shall not be considered a design manual.

1.2.6 Compliance with this standard shall not absolve the parties involved of their respective responsibilities for the design, installation, maintenance, performance, or compliance with other applicable standards and codes.

1.2.7 The installation of a stored-energy system(s) conforming to this standard shall ensure that alternate power is available to minimize life safety hazards resulting from power loss to certain continuous chemical or industrial processes, computer controlled systems, emergency lighting, and the like.

1.3 Application.

1.3.1 This document shall apply to new installations of SEPSS.

1.3.2 Existing systems shall not be required to be modified to conform except where the authority having jurisdiction determines that nonconformity presents a distinct hazard to life.

1.4 Equivalency. Nothing in this standard shall be intended to prevent the use of systems, methods, or devices of equivalent or superior quality, strength, fire resistance, effectiveness, durability, and safety to those prescribed by this document, provided the requirements of 1.4.1 and 1.4.2 are met.

1.4.1 Technical documentation shall be submitted to the authority having jurisdiction to demonstrate equivalency.

1.4.2 The system, method, or device shall be approved for the intended purpose by the authority having jurisdiction.

1.5 Function.

1.5.1 SEPSS shall provide a source of electrical power of required capacity, reliability, and quality to loads for a given length of time within a specified time after loss, failure, or disruption of the normal power supply.

1.5.2 An SEPSS shall include a means to recharge the stored-energy system.

Chapter 2 Referenced Publications

2.1 General. The documents or portions thereof listed in this chapter are referenced within this standard and shall be considered part of the requirements of this document.

2.2 NFPA Publications. National Fire Protection Association, 1 Batterymarch Park, Quincy, MA 02169-7471.

NFPA 1, *Fire Code*, 2018 edition.

NFPA 70®, *National Electrical Code*®, 2017 edition.

NFPA 72®, *National Fire Alarm and Signaling Code*®, 2016 edition.

2.3 Other Publications.

2.3.1 ASCE Publications. American Society of Civil Engineers, 1801 Alexander Bell Drive, Reston, VA 20191-4400.

ASCE/SEI 7, *Minimum Design Loads for Buildings and Other Structures*, 2010.

2.3.2 Other Publications.

Merriam-Webster's Collegiate Dictionary, 11th edition, Merriam-Webster, Inc., Springfield, MA, 2003.

2.4 References for Extracts in Mandatory Sections.

NFPA 1, *Fire Code*, 2018 edition.

NFPA 110, *Standard for Emergency and Standby Power Systems*, 2016 edition.

Chapter 3 Definitions

3.1 General. The definitions contained in this chapter shall apply to the terms used in this standard. Where terms are not defined in this chapter or within another chapter, they shall be defined using their ordinarily accepted meanings within the context in which they are used. *Merriam-Webster's Collegiate Dictionary*, 11th edition, shall be the source for the ordinarily accepted meaning.

3.2 NFPA Official Definitions.

3.2.1* Approved. Acceptable to the authority having jurisdiction.

3.2.2* Authority Having Jurisdiction (AHJ). An organization, office, or individual responsible for enforcing the requirements of a code or standard, or for approving equipment, materials, an installation, or a procedure.

3.2.3 Labeled. Equipment or materials to which has been attached a label, symbol, or other identifying mark of an organization that is acceptable to the authority having jurisdiction and concerned with product evaluation, that maintains periodic inspection of production of labeled equipment or materials, and by whose labeling the manufacturer indicates compliance with appropriate standards or performance in a specified manner.

3.2.4* Listed. Equipment, materials, or services included in a list published by an organization that is acceptable to the authority having jurisdiction and concerned with evaluation of products or services, that maintains periodic inspection of production of listed equipment or materials or periodic evaluation of services, and whose listing states that either the equipment, material, or service meets appropriate designated standards or has been tested and found suitable for a specified purpose.

3.2.5 Shall. Indicates a mandatory requirement.

3.2.6 Should. Indicates a recommendation or that which is advised but not required.

3.2.7 Standard. An NFPA Standard, the main text of which contains only mandatory provisions using the word “shall” to indicate requirements and that is in a form generally suitable for mandatory reference by another standard or code or for adoption into law. Nonmandatory provisions are not to be considered a part of the requirements of a standard and shall be located in an appendix, annex, footnote, informational note, or other means as permitted in the NFPA Manuals of Style. When used in a generic sense, such as in the phrase “standards development process” or “standards development activities,” the term “standards” includes all NFPA Standards, including Codes, Standards, Recommended Practices, and Guides.

3.3 General Definitions.

3.3.1 Battery. Two or more cells connected together electrically in series or parallel, or both, to provide the required operating voltage and current levels.

3.3.1.1* Lead-Acid (LA) Cell. A secondary cell in which the active material of the positive electrode is lead dioxide, the active material of the negative electrode is lead, and the electrolyte is dilute sulfuric acid.

3.3.1.1.1* Valve-Regulated (VRLA). A lead-acid battery consisting of sealed cells furnished with a valve that opens to vent the battery whenever the internal pressure of the battery exceeds the ambient pressure by a set amount. [1, 2018]

3.3.1.1.2* Vented (Flooded). A lead-acid battery consisting of cells that have electrodes immersed in liquid electrolyte. [1, 2018]

3.3.1.2 Nickel-Cadmium (NiCd) Cell. A secondary cell in which the active material of the positive electrode is nickel oxyhydroxide, the active material of the negative electrode is cadmium, and the electrolyte is dilute potassium hydroxide.

3.3.1.3 Nickel-Metal Hydride (NiMH) Cell. A secondary cell in which the active material of the negative electrode is a hydrogen-absorbing alloy and the positive electrode is nickel.

3.3.2* Bridging System. A type of energy conversion equipment (ECE) intended to temporarily support the critical load with stored energy until an alternate energy source can assume the load.

3.3.3* Electrochemical Energy Storage Device. A device based on the interrelated transformations of chemical and electric energy, usually consisting of an anode, a cathode, and an electrolyte plus such connections (electrical and mechanical) as needed to allow the cell to deliver or receive electric energy.

3.3.4 Emergency Power Supply. See 3.3.8.1.

3.3.5 Emergency Power Supply System (EPSS). A complete functioning EPS system coupled to a system of conductors, disconnecting means and overcurrent protective devices, transfer switches, and all control, supervisory, and support devices up to and including the load terminals of the transfer equipment needed for the system to operate as a safe and reliable source of electric power. [110, 2016]

3.3.5.1 Stored-Energy Emergency Power Supply System (SEPSS). A system consisting of a UPS, a rectifier plant, or a motor generator powered by a stored electrical energy source; a transfer switch designed to monitor preferred and alternate load power source and provide desired switching of the load; and all necessary control equipment to make the system functional.

3.3.6 Energy Conversion Equipment (ECE). A system of either a UPS, a battery bank and battery charger (central battery system), or a rotating motor generator (with or without inertia flywheel), often supplied by a central battery system power source.

3.3.7 Internal Ohmic Measurement. A measurement of the electronic and ionic conduction path within a cell or unit, using techniques commonly known as impedance, conductance, or resistance tests.

3.3.8 Power Supply.

3.3.8.1* Emergency Power Supply (EPS). The source of electric power of the required capacity and quality for an emergency power supply system (EPSS). [110, 2016]

3.3.8.2* Uninterruptible Power Supply (UPS). A device or system that provides quality and continuity of ac power through the use of a stored-energy device as the backup power source during any period when the normal power supply is incapable of performing acceptably.

3.3.9 Transfer Switch.

3.3.9.1 Automatic Transfer Switch (ATS). Self-acting equipment for transferring the connected load from one power source to another power source. [110, 2016]

3.3.9.2 Nonautomatic Transfer Switch. A device, operated manually by a physical action or electrically by either a local or remote control, for transferring a common load between a normal and alternate supply. [110, 2016]

Chapter 4 Classification of Stored-Energy Emergency Power Supply Systems (SEPSS)

4.1* General. Stored-energy emergency power supply systems (SEPSS) shall be classified as detailed in Sections 4.2 through 4.5.

4.2 Type.

4.2.1 The type shall determine the maximum time, in seconds, that the SEPSS will permit the load terminals of the transfer switch to be without acceptable electrical power.

▲ **4.2.2*** The interruption times of the SEPSS types covered by this standard shall be as provided in Table 4.2.2.

4.3* Class. The class shall determine the minimum time, in hours, for which the SEPSS is designed to operate at its rated load without being refueled or recharged as shown in Table 4.3.

4.4 Category. This standard shall regulate stored-energy devices into the following two categories:

- (1) Category A includes stored-energy devices receiving their energy solely from the normal supply under conditions of normal operation.
- (2) Category B includes all devices not included in Category A and not specifically excluded elsewhere in this standard.

4.5* Level. The level of equipment installation, performance, and maintenance shall be as specified in 4.5.1 through 4.5.5.

4.5.1* Level 1 systems shall be installed where failure of the equipment to perform could result in loss of human life or serious injuries.

4.5.2* Level 2 systems shall be installed where failure of the EPSS to perform is less critical to human life and safety.

4.5.3 All equipment shall be permanently installed.

4.5.4* Level 1 and Level 2 SEPSS shall supply alternate power of a quality that ensures reliable operation of the load, within the time determined by the type and for a duration determined by the class.

4.5.5* Other equipment and applications, including optional standby systems, not defined in Levels 1 and 2 are beyond the scope of this document.

▲ **Table 4.2.2 Types of SEPSS**

Type	Interruption Time
Type O	No interruptions — UPS carrying load, 0.0 sec
Type U	UPS system with utility as preferred source
Type A	0.25 cycle: 0.0042 sec
Type B	1.0 cycle: 0.0167 sec
Type 10	10 sec
Type M	Manual stationary or nonautomatic — no time limit

Table 4.3 Classes of SEPSS

Class	Reserve Time
Class 0.033	0.033 hr (2 min)
Class 0.083	0.083 hr (5 min)
Class 0.25	0.25 hr (15 min)
Class 1.5	1.5 hr (90 min)
Class X	Other time, in hours, as required by the application, code, or user

Chapter 5 Emergency Power Supply: Energy Sources, Convertors, Inverters, and Accessories

5.1 Energy Sources. The energy sources listed in this section shall be permitted for use for the emergency power supply (EPS).

5.1.1 Battery Systems.

5.1.1.1* Battery Types. Electrical storage batteries having a construction and chemical composition suitable for standby, float service operation shall consist of one of the following:

- (1) Lead-acid batteries (LA)
- (2) Nickel-cadmium batteries (NiCd)
- (3) Nickel-metal hydride batteries (NiMH)
- (4) Lithium ion (LI) batteries

5.1.1.2 Battery System Electrolyte. The following batteries shall be permitted with either free-flowing or immobilized electrolyte:

- (1) LA
- (2) NiCd
- (3) NiMH

5.1.1.3 Battery Installation. Battery installations shall comply with the following:

- (1) Vented batteries (LA, NiCd, NiMH) shall be installed in a room(s) dedicated to the batteries and associated equipment with approved ventilation.
- (2) Vented batteries shall be mounted on open racks.
- (3) Sealed and valve-regulated batteries (VRLA, NiMH, LI) shall be permitted in dedicated battery rooms. Batteries shall be mounted in either of the following ways:
 - (a) On open racks
 - (b) In listed battery cabinets
- (4) Distributed sealed and valve-regulated batteries (VRLA, NiMH, LI) shall be permitted in occupied spaces and shall be mounted in one of the following ways:
 - (a) In listed battery cabinets with restricted access (tool or key required)
 - (b) In listed console or package style
 - (c) In a combination of (a) and (b)

5.1.2* Mechanical Inertia Systems. Flywheel systems shall be installed in dedicated equipment rooms with restricted access or in enclosures with restricted access.

5.2 Energy Conversion Equipment (ECE) — General. ECE covered by this standard shall pertain to systems utilizing electrochemical devices, mechanical inertia devices, or both, with related control, conversion, and accessory items.

5.2.1* Bridging Systems. Bridging systems shall be capable of supporting the load for a finite period of time until the emergency or standby power source is able to assume the load.

5.2.1.1* The following electrochemical bridging systems shall be permitted:

- (1) Solid state (static) UPS systems of the following types:
 - (a) On-line UPS capable of assuming the load without interruption upon loss of the primary input source
 - (b) Standby and off-line (UPS) capable of assuming the load within a specified time frame and without interruption of the load operation upon loss of the primary input source

- (2) Ultracapacitor systems integrated into the following types of systems:

- (a) UPS systems capable of sustaining the load without interruption upon momentary loss or degradation of the primary input source with or without battery
- (b) Fuel cell systems capable of sustaining the load without interruption upon loss of input power until the fuel cell assumes the load

- (3) Solid state (static) rectifier plants capable of providing continuous power to the dc load(s) without interruption or disturbance upon loss of the primary input source

5.2.2 Mechanical Inertia Systems. Flywheel systems shall sustain the load without interruption upon momentary loss or degradation of input power until power is restored or an emergency or standby power source assumes the load.

5.2.3 Level. The ECE for each level shall be of proven design and components whose performance and reliability have been documented.

5.2.4 Class. The ECE shall be identified by the manufacturer for the specified class.

5.2.5 Output. The output of an ECE shall be of the voltages, waveform, and frequency rated for the load.

5.2.6 Temperature. ECEs shall be designed to operate over the following expected environmental temperature ranges:

- (1) Indoor: 10°C to 40°C (50°F to 104°F)
- (2) Outdoor: -34°C to 50°C (-30°F to 122°F)

5.2.7* Humidity. The ECE shall be designed to function in an atmosphere having a relative humidity that can vary from 5 percent to 95 percent, noncondensing.

5.2.8 Capacity.

5.2.8.1 Class. The ECE shall have the capacity to supply power for the class for which it is rated.

5.2.8.2 Stored-Energy Recovery. Following a power outage for the full duration of the assigned class, the ECE shall be capable of automatically resupplying the full rated load and duration within the time appropriate for the technology as follows:

- (1) Battery-based systems with a charger identified for the battery type and capable of recharging as follows:
 - (a) 80 percent within 12 times the discharge period
 - (b) 100 percent within 48 hours
- (2) Ultracapacitor-based systems: 100 percent within 1 hour
- (3) Mechanical inertia-based systems: 100 percent within 1 hour

5.3 Instrumentation.

5.3.1 Instruments. The SEPSS shall be provided with instruments or other approved display means, including remote annunciation capability, to indicate the requirements shown in Table 5.3.1, where applicable to the technology.

5.3.2 Indicators. Individual visual indicators and a common audible annunciator shall be provided for the requirements shown in Table 5.3.2.

5.3.3* Annunciation.

5.3.3.1 The following monitoring shall be provided at a minimum:

Table 5.3.1 Instrumentation Display Indicator

Device	Level	
	1	2
Battery voltage	X	X
System output voltage, each leg	X	X
System output current, each leg	X	X
System output frequency (ac output systems only)	X	X

X = Required.

Table 5.3.2 Visual Indicator Display Indicator

Device	Level	
	1	2
Load on normal power	X	X
Load on emergency power	X	X
Output circuit breaker open	X	O
Output overload/overcurrent	X	X
High temperature	X	X
ECE in bypass mode	X	X
Low battery (if present)	X	X
Major alarm condition	X	X
Minor alarm condition	X	X

X = Required. O = Not Required.

- (1) For Level 1 SEPSS, local annunciation and facility remote annunciation, or local annunciation and network remote annunciation
- (2) For Level 2 SEPSS, local annunciation

5.3.3.2 For the purposes of this section, the following shall be permitted:

- (1) Local annunciation located on the equipment itself or within the same equipment room.
- (2) Facility remote annunciation located on site but not within the room where the equipment is located.
- (3) Network remote annunciation located off site.

Chapter 6 Transfer Switches and Protection

6.1 General.

6.1.1* Switching, as used in this chapter, shall refer to any electrical or electronic equipment that is used as follows:

- (1) To transfer an electrical load from one power source to another
- (2) To perform load-switching or load-shedding functions on any electrical load
- (3) To bypass, isolate, and test any transfer or isolation switch in the static system
- (4) To isolate any faulted component inside the static system so that it ceases to be connected to the output load terminals
- (5) To bypass the energy conversion equipment (ECE)

6.1.2 Protection, as used in this chapter, shall reference electronic-sensing or inherent overload protective devices, such as fuses, automatic breakers, or both, that are used to protect

the static system against damage caused by faults or overloads on either the output of the static system in its loads or conductors, or on internal faults in the static system.

6.1.3* Equipment used with batteries or other dc sources shall be identified and rated for the dc voltage and current.

6.2 Transfer Switches.

6.2.1 General. Transfer switches shall be rated for transferring the connected loads between the energy converter and the building electrical service.

6.2.1.1 Transfer switches shall be permitted to be electrical or electronic or a hybrid of both.

6.2.1.2 Any transfer switch shall be rated for transferring all connected electrical loads from one power source to another.

6.2.1.3 Transfer switch characteristics shall be sized for the connected electrical load.

6.2.1.4 Transfer switches shall provide rated isolation between the electrical load and the alternate source(s).

6.2.1.5 Transfer switches shall be permitted to be separate devices within their own enclosures or an integral part of the ECE.

6.2.1.6 The capacity and endurance rating of transfer switches shall be sized for all classes of loads to be served.

6.2.1.7 The method of operation of transfer switches shall ensure that the most likely causes of switch failure result in the loads being connected to the building service.

6.2.1.8 Means shall be provided to check the operation of the transfer switch.

6.2.2* Switch Capacity.

6.2.2.1 The capacity of the transfer switch, electronic or electromechanical, shall be rated for all classes of loads to be served.

6.2.2.2 The transfer switch, including all load current-carrying components, shall be rated to withstand the effects of available fault currents.

6.2.3 Transfer Switch Classification.

6.2.3.1 Each transfer switch shall be listed for emergency service as a completely factory-assembled and factory-tested apparatus unless under the conditions of 6.2.3.2.

6.2.3.2 Electronic or electromechanical switches that constitute an integral part of the ECE shall be permitted, provided they form part of a listed equipment.

6.2.4 Automatic Transfer Switch (ATS) Features.

6.2.4.1 General. Automatic transfer switches shall be electrically or electronically operated.

6.2.4.1.1 The transfer of the load from one source to another source shall be permitted to be automatic.

6.2.4.1.2 The retransfer shall be permitted to be automatically or manually initiated.

6.2.4.2 Source Monitoring. The preferred source shall be monitored for undervoltage and overvoltage on all its ungrounded input lines.

6.2.4.2.1 The ECE and the utility shall be monitored for unacceptable conditions.

6.2.4.2.2 If a condition that is out of tolerance is sensed, the transfer switch shall automatically switch to the alternate source(s) of power, provided that the alternate source(s) of power itself is within tolerance.

6.2.4.2.3 When the preferred source of power returns to levels of output within equipment tolerance in its sensed parameters as described in 6.2.4.2, the transfer switch shall be capable of initiating an automatic transfer to the preferred source.

6.2.4.2.4 An adjustable time delay shall be allowed to ensure that the preferred source is within its steady-state specification limits before such retransfer is performed.

6.2.4.2.5 Provision for retransfer to the preferred source also shall be available under manual command, provided the preferred source is within tolerance.

6.2.4.2.6 Retransfer shall be permitted to be sequenced if desired to pick up heavy loads without introducing further disturbances.

6.2.4.3 Interlocking.

6.2.4.3.1 Interlocking shall be provided to prevent inadvertent interconnection of the preferred and alternate power sources unless under the conditions of 6.2.4.3.2.

6.2.4.3.2 Where interconnection is inherent in the system design, the preferred and alternate sources of power shall not be connected together longer than is necessary to transfer the preferred sources of power, without disturbance to the electrical loads connected to it, provided that such interconnection can be sustained by the two connected sources of incoming power without causing internal current protection features to be initiated.

6.2.4.4* Manual Operation. Instruction and equipment shall be provided for the manual nonelectric transfer or bypass in the event the automatic transfer switch malfunctions.

6.2.4.5* Time Delay on Retransfer to Preferred Source.

6.2.4.5.1 An adjustable time delay device with automatic bypass shall be provided to delay retransfer from the alternate source to the preferred source of power.

6.2.4.5.2 The time delay shall be automatically bypassed if the ECE or EPS fails.

6.2.4.6 Test Switch.

6.2.4.6.1 A test switch shall be provided on each automatic transfer switch that simulates failure of the preferred power source.

6.2.4.6.2 The automatic transfer switch shall perform its intended function when the test switch is activated.

6.2.5 Nonautomatic Transfer Switch Features.

6.2.5.1 General. Manual control of switching devices shall be permitted to be either local or remote.

6.2.5.1.1 When initiated, a device shall switch to its alternate state and shall remain in that state.

6.2.5.1.2 Upon cessation of the initiating control action, the device shall return to its preferred state.

6.2.5.2 Interlocking. Reliable mechanical interlocking, or an approved alternate method, shall prevent the inadvertent interconnection of the preferred and alternate power sources or of any two separate sources of power.

6.2.5.3 Indication of Switch Position. Two pilot lights with identification nameplates, or other approved position indicators, shall be provided to indicate the switch position.

6.3 Load Switching (Load Shedding).

6.3.1 General. When the connected load exceeds the capacity of the ECE, system controls shall automatically do one of the following:

- (1) Disconnect pre-identified noncritical loads
- (2) Transfer the loads to bypass

6.3.2 Transfer Switch Rating.

6.3.2.1 Each transfer switch shall have a continuous current rating and interrupting rating for all classes of loads to be served.

6.3.2.2 The transfer switch shall be capable of withstanding the available fault current at the point of installation.

6.3.3 Operation. First priority loads shall be switched to the emergency bus (if not already on that bus) when the emergency source is made available to their switching devices.

6.3.3.1 The remaining lower priority loads shall be switched to the emergency bus thereafter, provided the emergency bus is not overloaded by such switching, until all such emergency loads of lower priority are on the emergency bus.

6.3.3.2 The total loading on the emergency bus also shall be reduced by switching off the loads in inverse priority order, in proportion to the lost power capacity of the isolated module, when both of the following conditions exist:

- (1) Any static power module connected to the emergency bus is isolated from that bus due to internal failure.
- (2) The remaining connected power modules cannot serve the total connected load because they are overloaded.

6.3.3.3 Disconnecting the lower priority loads (load shedding) shall cease when the load demand matches the connected capacity of the remaining modules.

6.4 Bypass Switches.

6.4.1* Isolation. Bypass switches, with or without isolation, shall be permitted for bypassing or for bypassing and isolating the transfer switch, and if installed, bypass switches shall be in accordance with 6.4.2 and 6.4.3.

6.4.2 Bypass Switch Rating. The bypass switch shall have a continuous current rating and shall withstand a current rating compatible with that of the associated transfer switch.

Exception: UPS static bypass transfer switches shall be permitted to have a current rating and interrupting rating for all classes of loads to be served sufficient to support all connected loads from either source.

6.4.3 Bypass Switch Classification. Each bypass switch shall be designed for emergency electrical service as a completely factory-assembled and factory-tested apparatus.

6.5 Protection.

6.5.1* General.

6.5.1.1 The overcurrent protective devices in the SEPSS shall be coordinated to ensure selective tripping of the circuit overcurrent protective devices when a short-circuit current occurs.

6.5.1.2 The maximum available short-circuit current from both the utility source and the emergency energy source shall be evaluated to verify compliance with this coordination.

6.5.2 Overcurrent Protective Device Rating.

6.5.2.1 The rating of integral devices (e.g., fuses or breakers) shall be coordinated with the rating of downstream protective devices, taking into account the prospective short-circuit current available from the connected upstream power sources, such that the downstream devices operate first to eliminate the least critical portion of the connected electrical load.

6.5.2.2 In those cases where electronic protection is incorporated via feedback to limit the current output of the ECE, the internal transfer switch(es) shall operate to switch the connected electrical load to the alternate source.

6.5.3 Accessibility. Overcurrent devices in EPSS circuits shall be accessible to authorized persons only.

Chapter 7 Installation and Environmental Considerations

7.1 General.

7.1.1 This chapter shall provide the minimum requirements and considerations for an SEPSS relative to the installation and environmental conditions that could adversely affect its performance.

7.1.2 When the location of the SEPSS is evaluated, consideration shall be given to the geographic location, building type, classification of occupancy, and hazardous nature of the area.

7.1.3 The SEPSS equipment shall be installed in a manner and location recommended by the manufacturer and acceptable to the authority having jurisdiction.

7.1.4 Where normal power is available, the EPS shall serve Level 1 and Level 2 system loads and shall be permitted to serve additional loads, provided that, on failure of the normal power, the additional loads are automatically dropped to ensure that the EPS has sufficient capacity to serve the Level 1 and Level 2 loads.

7.2 Location.

7.2.1* The SEPSS shall be located in a room(s) in accordance with the manufacturer's environmental specifications.

7.2.1.1 The location of SEPSS equipment serving Level 1 EPSS loads shall not be installed in the same room with the normal supply equipment, where the supply equipment is rated over 150 volts to ground and equal to or greater than 1000 amperes.

7.2.2 The rooms or buildings housing the SEPSS shall be located to minimize the possibility of damage from flooding, including flooding resulting from fire fighting, sewer water backup, and similar disasters or occurrences.

7.2.3 SEPSS Equipment.

7.2.3.1 The SEPSS equipment shall be installed in a location that allows for equipment accessibility and working space clearance for the inspection, repair, maintenance, cleaning, or replacement of the unit per Table 110.26(A)(1) of *NFPA 70 (NEC)*.

7.2.3.2 A separate unit emergency lighting system shall be provided at the SEPSS location if no other emergency lighting is present.

7.3 Heating, Cooling, Ventilating, and Humidity Control.

7.3.1 The SEPSS shall be located in an area provided with heating and cooling capable of ensuring, both during the time that normal power is available and during an emergency, that the equipment is operated within the manufacturer's ambient temperature specifications. (*See also 5.2.6.*)

7.3.2 Provisions shall be made for sufficient diffusion and ventilation of the flammable gases from the battery or other electrochemical energy storage devices to limit the concentration of flammable gas in accordance with NFPA 1 or other applicable codes.

7.3.3 Ventilation.

7.3.3.1* For SEPSS equipment using free-flowing liquid electrolyte (a.k.a. vented or flooded) batteries in which vents allow the continuous evolution and release of gases into the battery space, ventilation openings or airflow shall be situated to limit the possibility of the buildup of gas pockets in accordance with NFPA 1.

7.3.3.2 Where needed, fans used to circulate and exhaust air shall use motors designed for the application. (*See Article 480, NFPA 70.*)

7.4 Protection.

7.4.1 The room in which the EPS equipment is located shall not be used for storage purposes.

7.4.2 Where SEPSS equipment rooms or separate buildings are equipped with fire suppression, one of the following systems that is compatible with the battery or other electrochemical type shall be used:

- (1) Clean agent gaseous systems
- (2) Pre-action systems
- (3) Other suppression systems approved by the AHJ

7.4.3 Where SEPSS equipment rooms are equipped with fire detection systems, the installation of the fire detection system shall be in accordance with applicable standards. (*See NFPA 72.*)

7.4.4 The SEPSS equipment shall be protected from voltage transients due to lightning.

7.4.5* Seismic Risk.

7.4.5.1 In seismic design categories C, D, E, and F, as determined in accordance with ASCE 7/SEI 7, *Minimum Design Loads for Buildings and Other Structures*, the equipment shall be designed to reduce the risk of failure caused by the anticipated seismic ground motion.

7.4.5.2 Components of an SEPSS shall be assigned a component importance factor of 1.5, per ASCE 7/SEI 7, *Minimum Design Loads for Buildings and Other Structures*.

7.4.5.3 The batteries shall be restrained in position, to limit the chance of spillage or breakage due to the anticipated seismic ground movement.

7.4.5.4 Outgoing bus bars and cables on battery systems shall be braced in such a manner as to limit the chance of post rupture where seismic ground movement is anticipated.

7.5 Distribution.

7.5.1 The grounding, distribution, and wiring systems within the EPS shall be installed in accordance with applicable standards. (See *NFPA 70*.)

7.5.2 The electrical distribution system within the SEPSS shall be complete with overcurrent and fault current protective equipment designed and sized for the system.

7.5.3 Overcurrent protective devices for batteries or other dc sources shall be located as close as practical to the stored-energy source to minimize possibility of fault.

7.5.4 Storage batteries used to power the SEPSS shall be located as close to the SEPSS as practicable and shall be connected using cable that is sized to limit the voltage drop to levels within the SEPSS manufacturer's specifications.

7.6 Installation Acceptance.

7.6.1 Upon completion of the installation of the SEPSS, the system shall be tested to ensure conformity with the requirements of this standard with respect to both power output and function.

7.6.2 An on-site acceptance test shall be conducted to determine final approval for all SEPSS.

7.6.2.1 For battery-based systems, the on-site test shall be conducted in the following manner:

- (1) With the batteries fully charged and with a connected load bank at rated value, a normal power failure shall be initiated by opening all switches or breakers supplying the normal power to that load.
- (2) All emergency loads, including those not normally energized, shall be included in the on-site test.
- (3) The time delay between initiation of the power failure and the assumption of the load by the EPS shall be observed and recorded.
- (4) The voltage and current supplied to the emergency load and, where applicable, the frequency, waveform, and transients shall be recorded.
- (5) The load test shall be continued for 15 minutes or the rated time (class), whichever is shorter, and the following shall be observed and recorded:
 - (a) Voltage and current to the load
 - (b) Voltage and current of the battery bank
 - (c) Where applicable, the frequency
- (6) The normal power shall be restored to the monitored circuit.
- (7) The transfer time shall be observed.

7.6.2.2 Immediately following the test specified in 7.6.2.1, the SEPSS shall be connected to the normal power for 24 hours. (See *5.2.8.2*.)

7.6.2.3 System Load Test. A system load test shall be initiated following the recharge period required in 7.6.2.2.

7.6.2.3.1 The system load test shall be permitted to be performed on the site-connected load; however, a load bank shall be permitted to be used to augment the site-connected load, provided that it is sized to be equal to the ECE rating.

7.6.2.3.2 The unity power factor for an ac SEPSS shall be permitted, provided that rated load tests at the rated power factor are within the design parameters stated by the manufacturer of the SEPSS.

7.6.2.3.3 The duration of the load test shall be 100 percent of the class for which the SEPSS is rated.

7.6.2.3.4 The following procedure shall be utilized:

- (1) A normal power failure shall be initiated by opening all switches or breakers supplying the normal power to that load.
- (2) All emergency loads, including those not normally energized, shall be included in the on-site test.
- (3) The time delay between initiation of the power failure and the assumption of the load by the EPS shall be observed and recorded.
- (4) The voltage and current supplied to the emergency load and, where applicable, the frequency, waveform, and transients shall be recorded.
- (5) The load test shall be continued for 15 minutes or the rated time (class), whichever is shorter, and the following shall be observed and recorded:
 - (a) Voltage and current to the load
 - (b) Voltage and current of the battery bank
 - (c) Where applicable, the frequency
- (6) The normal power shall be restored to the monitored circuit.
- (7) The transfer time shall be observed.

7.6.3* Any battery cells or multicell units, transfer switches, or other system components that have failed shall be replaced and so noted on test reports or records, after which the system shall be retested.

7.6.4 The following shall be made available to the authority having jurisdiction at the time of the acceptance test:

- (1) Factory test data on the completed system
- (2) Battery specifications
- (3) Vendor's certificate of compliance to the specification

7.6.5 Baseline Measurement. A permanently installed method of monitoring lead-acid batteries shall be permitted based on ohmic measurements.

7.6.5.1* Ohmic measurements shall be taken of every cell within the battery system after approximately 6 months of operation following the full load test described in 7.6.2.3, or 2 weeks following the most recent discharge thereafter.

7.6.5.1.1 Measurements shall be taken on a fully charged battery while float charging.

7.6.5.1.2 The data shall be recorded to establish a baseline against which all future measurements will be compared.

Chapter 8 Routine Maintenance and Operational Testing

8.1 General. The SEPSS shall have routine maintenance and operational testing based on the manufacturer's recommendations, instruction manuals, and the minimum requirements of

this chapter and subject to the approval of the authority having jurisdiction.

8.2 Manuals, Special Tools, and Spare Parts.

8.2.1 At least two sets of instruction manuals for the SEPSS shall be supplied by the manufacturer of the SEPSS and shall contain the following:

- (1) A detailed explanation of the operation of the system
- (2) A schematic wiring diagram
- (3) A function block diagram
- (4) The energy storage device's specification, installation instructions, maintenance information, and wiring diagrams
- (5) Instructions for routine maintenance
- (6) Recommended spare parts list with part numbers and part sources
- (7) Routine troubleshooting procedures

8.2.2 For Level 1, one set of the instructions shall be kept with the equipment, and the other set shall be kept in another secure location.

8.2.3 Special tools and testing devices required for routine maintenance shall be available for use when needed.

8.3 Maintenance and Operational Testing.

8.3.1 The SEPSS shall be maintained so that the system is capable of supplying the service quality within the time specified for the type and for the time duration specified for the class.

8.3.2* A routine maintenance and operational testing program shall be initiated immediately following the acceptance test or any repair or component replacement, including battery replacement. (See Table A.8.3.2 and Figure A.8.4.2 for guidance.)

8.3.3 Reproducible Records.

8.3.3.1 A reproducible record of inspection, tests, and repairs shall be maintained on the premises. (See Table A.8.3.2.)

8.3.3.2 The record shall include the following:

- (1) Completion of a log
- (2) Notification of any unsatisfactory condition and the corrective actions taken, including parts replaced
- (3) Identification of the servicing personnel
- (4) Documentation of a completed test of the SEPSS, according to 8.4.1, immediately following any repair or battery replacement

8.4 Operational Inspection and Testing.

8.4.1* Level 1 equipment shall be inspected monthly and tested in accordance with the manufacturer's recommendations. (See Figure A.8.4.2.)

8.4.2* Inspection of the equipment shall include the following:

- (1) The battery and associated charger/control equipment shall be checked to verify that they are in a clean and satisfactory condition and that no exceptional environmental or other conditions exist that could damage or affect performance.
- (2) Battery electrolyte levels shall be checked, where applicable, and refilled as necessary.

- (3) Terminals and intercell connectors shall be cleaned and regreased, if necessary, and cell tops shall be cleaned.
- (4) Individual cell voltages shall be checked and recorded where practical.
- (5) The specific gravity of pilot cells shall be checked and recorded, where applicable.
- (6) The conditions of the plates and sediment of free-electrolyte, LA batteries in transparent containers shall be noted.
- (7) All indicator lamps, meters, and controls shall be checked to verify that they are operating correctly.
- (8) The load value shall be checked to ensure that it is within the equipment rating.

8.4.3 Load Testing.

8.4.3.1 A load test shall be performed as required by 8.4.1. The output voltage, battery voltage, and duration of the test shall be recorded at the beginning and at the end of the test for each battery set.

8.4.3.2 When a method of ohmic measurements is used to monitor LA batteries, the results shall be maintained and checked for deviance from the baseline established in 7.6.5.

8.4.3.2.1 If data indicate deviation outside an acceptable range, the battery shall be load tested for the full duration for its class.

8.4.3.2.2 A fully rated load bank shall be used in lieu of an actual load, provided it is sized to be equal to the ECE rating.

8.4.4 The SEPSS shall be tested annually by one of the following methods:

- (1) At 100 percent of its rated load for 60 percent duration of its rated class
- (2) At 60 percent of its rated load for 100 percent duration of its class

8.4.5 A written record of all checks and tests in 8.4.2 shall be maintained and shall be accessible to the authority having jurisdiction. (See Figure A.8.4.2.)

8.4.6 The routine maintenance and operational testing program shall be performed by qualified personnel.

Annex A Explanatory Material

Annex A is not a part of the requirements of this NFPA document but is included for informational purposes only. This annex contains explanatory material, numbered to correspond with the applicable text paragraphs.

A.1.1.1 This document applies to stored-energy power systems that are used in lieu of the systems defined in NFPA 110. For emergency power systems supplied by emergency generators, see NFPA 110. Such systems are regulated in Articles 700 and 701 of NFPA 70 (NEC).

A.1.1.4.1 Optional standby systems are described in Article 702 of NFPA 70 (NEC).

A.3.2.1 Approved. The National Fire Protection Association does not approve, inspect, or certify any installations, procedures, equipment, or materials; nor does it approve or evaluate testing laboratories. In determining the acceptability of installations, procedures, equipment, or materials, the authority having jurisdiction may base acceptance on compliance with NFPA or other appropriate standards. In the absence of such

standards, said authority may require evidence of proper installation, procedure, or use. The authority having jurisdiction may also refer to the listings or labeling practices of an organization that is concerned with product evaluations and is thus in a position to determine compliance with appropriate standards for the current production of listed items.

A.3.2.2 Authority Having Jurisdiction (AHJ). The phrase “authority having jurisdiction,” or its acronym AHJ, is used in NFPA documents in a broad manner, since jurisdictions and approval agencies vary, as do their responsibilities. Where public safety is primary, the authority having jurisdiction may be a federal, state, local, or other regional department or individual such as a fire chief; fire marshal; chief of a fire prevention bureau, labor department, or health department; building official; electrical inspector; or others having statutory authority. For insurance purposes, an insurance inspection department, rating bureau, or other insurance company representative may be the authority having jurisdiction. In many circumstances, the property owner or his or her designated agent assumes the role of the authority having jurisdiction; at government installations, the commanding officer or departmental official may be the authority having jurisdiction.

A.3.2.4 Listed. The means for identifying listed equipment may vary for each organization concerned with product evaluation; some organizations do not recognize equipment as listed unless it is also labeled. The authority having jurisdiction should utilize the system employed by the listing organization to identify a listed product.

A.3.3.1.1 Lead-Acid (LA) Cell. Multiple cells make up an LA battery. LA cells are often further identified by the type of lead alloy. Most common is “lead-calcium.” “Lead antimony” and “lead selenium” are also used.

A.3.3.1.1.1 Valve-Regulated (VRLA). In VRLA batteries, the liquid electrolyte in the cells is immobilized in an absorbent glass mat (AGM cells or batteries) or by the addition of a gelling agent (gel cells or gelled batteries).

A.3.3.1.1.2 Vented (Flooded). Flooded lead-acid batteries have a provision for the user to add water to the cell and are equipped with a flame-arresting vent that permits the escape of hydrogen and oxygen gas from the cell in a diffused manner such that a spark, or other ignition source, outside the cell will not ignite the gases inside the cell. [1, 2015]

A.3.3.2 Bridging System. A bridging system is an electrical system used to support the load only long enough to allow transfer to an alternate energy source (such as an emergency or standby generator, fuel cells, or an alternate utility source). Common bridging systems are rotary, static, or hybrid UPS systems.

A.3.3.3 Electrochemical Energy Storage Device. Examples of electrochemical energy storage devices include batteries and ultracapacitors.

A.3.3.8.1 Emergency Power Supply (EPS). The supply includes all the related electrical and mechanical components of the proper size and/or capacity required for the generation of the required electrical power at the EPS output terminals.

For rotary energy converters, components of an EPS include the following:

- (1) Prime mover
- (2) Cooling system

- (3) Generator
- (4) Excitation system
- (5) Starting system
- (6) Control system
- (7) Fuel system
- (8) Lube system (if required)

For stationary fuel cell systems, components of an EPS include the following:

- (1) Fuel cell stack
- (2) Cooling system
- (3) Fuel system (pure H₂, reformer system or natural gas)
- (4) Air supply
- (5) Exhaust system (cathode, purge)
- (6) Starting system (batteries, ultracapacitors)
- (7) Control system
- (8) Power conversion system

Chemically derived stored-energy emergency supplies include, but are not limited to, batteries and fuel cells.

A.3.3.8.2 Uninterruptible Power Supply (UPS). The UPS usually monitors and tracks the voltage and frequency of the normal source. It could be the preferred or alternate source of power to the load.

A.4.1 The terms *emergency power supply systems (EPSS)* and *standby power supply systems*, as used in this standard, include such other terms as *alternate power systems*, *standby power systems*, *legally required standby systems*, *alternate power sources*, and other similar terms. Because this standard specifies the installation, performance, maintenance, and test requirements in terms of types, classes, categories, and levels, any one of the terms listed might be appropriate to describe the application or use, depending on the need and the preference of the parties involved.

For optional standby systems, see Article 702 of *NFPA 70 (NEC)*.

A.4.2.2 Table 4.2.2 includes two types of uninterruptible power supply (UPS). UPS systems are available today that are capable of operation in more than one normal mode of operation. Typically, each normal mode will have a different input dependency characteristic, depending on whether the UPS output creates a new source of voltage and frequency or passes through to the load the same voltage and/or frequency characteristics of the input when not operating from its stored-energy source (e.g., battery). Some UPS have a single mode of operation, whereas other UPS can allow the user to select from among multiple modes of operation. The U.S. Environmental Protection Agency (EPA) has adopted the terminology of IEC 62040-3, *Uninterruptible Power Systems (UPS)-Part 3: Method of Specifying the Performance and Test Requirements*, which identifies the following modes of operation:

Voltage and Frequency Dependent (VFD) — Typical of an off-line UPS. Loads are supported by straight utility power until the source goes out of tolerance, at which time the UPS switches to its stored energy and inverter. VFD types typically have the best efficiency but lowest power quality. This is an example of an interruption Type U.

Voltage Independent (VI) — Typical of a line-interactive UPS, in which there could be voltage regulation, transient protection, or both, but frequency tracks the input source. VI types typi-

cally have moderate efficiency and moderate power quality. This is an example of an interruption Type U.

Voltage and Frequency Independent (VFI) — Typical of a double conversion UPS, in which both voltage and frequency are independently created by the UPS inverter. VFI types typically have somewhat lower efficiency but offer the highest power quality. This is an example of a interruption Type O.

Some UPS are able to sense a power abnormality and switch from one operating mode to another, with a time delay typically ranging from $\frac{1}{2}$ to $1\frac{1}{2}$ cycles. Continued operation (availability) of the load depends on the ability of its internal stored energy (e.g., capacitors) to hold it up during transfer. Only full double conversion meets Type O — all others will have some degree of transfer time that will vary depending on conditions.

A.4.3 Selection of the EPS class should take into account past outage records and fuel delivery problems due to weather and other geographic/environmental conditions. For SEPSS with batteries, the values shown in Table 4.3 assume capacity at the end of life. The end of life for lead-acid batteries is typically defined as the point at which a battery can no longer deliver 80 percent or more of its rated capacity. The end of life can vary for different types of batteries.

A.4.5 It is recognized that an SEPSS is utilized in many different locations and for many different purposes. The requirement for one application might not be appropriate for another application.

A.4.5.1 Typically, Level 1 systems are intended to automatically supply illumination, power, or both, to critical areas and equipment in the event of failure of the normal supply or in the event of damage to elements of a system intended to supply, distribute, and control power and illumination essential for safety to human life.

Level 1 systems generally are installed in places of assembly where artificial illumination is necessary for safe exiting and for panic control in buildings subject to occupancy by large numbers of people. Level 1 systems correspond to Article 700 of *NFPA 70 (NEC)* for emergency systems.

Emergency systems also can provide power for such functions as uninterruptible power supplies, ventilation where essential to maintain life, fire detection and alarm systems, public safety communications systems, industrial processes where current interruption would produce serious life safety or health hazards, and similar functions. (See *NFPA 101 and Chapter 6 of NFPA 99*.)

A.4.5.2 Typically, Level 2 systems are intended to supply power automatically to selected loads (other than those classed as emergency systems) in the event of failure of the normal source.

Level 2 systems typically are installed to serve loads such as heating and refrigeration systems, communication systems, ventilation and smoke removal systems, sewage disposal, lighting, and industrial processes that, when stopped due to any interruption of the normal electrical supply, could create hazards or hamper rescue or fire-fighting operations. Level 2 systems correspond to Article 701 of *NFPA 70 (NEC)* for legally required standby systems.

A.4.5.4 It is important to recognize that an SEPSS can react in a manner substantially different from commercial power during transient and short-circuit conditions because of the

relatively small capacities of the SEPSS as compared to a commercial power source.

See ANSI/NEMA C84.1, *American National Standard for Electric Power Systems and Equipment — Voltage Ratings (60 Hertz)*.

A.4.5.5 A UPS has stored energy (e.g., batteries) and could function as a bridging system in an EPSS. The UPS would be classified as an optional standby system, even though it is part of the greater EPSS.

A.5.1.1.1 Other emerging battery types have potential for use in SEPSS but have yet to become widely accepted in the industry. These include, but are not limited to, sodium metal-halide, sodium sulfur, vanadium redox, polysulphide bromide, and zinc bromine.

A.5.1.2 See Figure A.5.1.2(a) and Figure A.5.1.2(b) for examples of typical flywheel and rotating EPS systems.

A.5.2.1 Bridging systems can be used where Article 700 of *NFPA 70 (NEC)* requires an auxiliary power supply.

A.5.2.1.1 The requirements of 5.2.1.1 apply specifically to those solid state (static) UPS systems intended to supply power to the emergency loads during an interruption of the main power source (usually utility power) until an alternate source of power is available (such as a standby or emergency generator per *NFPA 110*). The intent is to cover electronic types of stored-energy systems in which power must be restored automatically and electrically when electrical power is restored to the ECE from a stable source. Mechanical inertia systems are specifically not included in the section.

A.5.2.7 If the ambient temperature in the location falls below 20°C (68°F), anticondensation measures should be considered.

A.5.3.3 The minimum “remote alarm annunciation” is to alert personnel at a constantly attended station somewhere on the

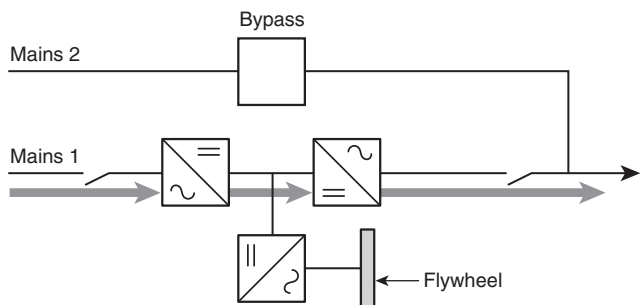

FIGURE A.5.1.2(a) UPS Using Flywheel as Energy Storage.

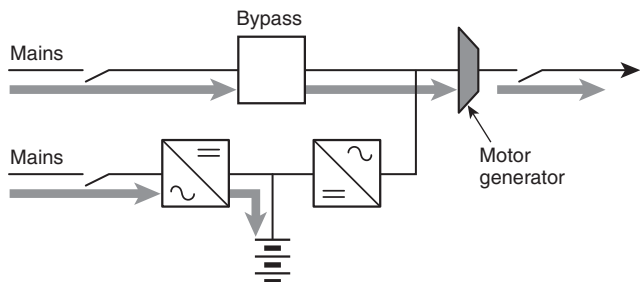

FIGURE A.5.1.2(b) Motor-Generator High Impedance Line Interactive Topology.

site when the facility is in use as a Level 1 system. If the site is not continuously occupied, “network remote” should allow people at another site to know the operating status of the equipment.

The preferred method of remote annunciation is to notify personnel both somewhere on the site and at other locations via a network such as LAN, WAN, or Internet, including the ability to initiate auto-dial and send predefined text messages.

A.6.1.1 It is the intent of 6.1.1 to apply to any point in the system at which power is transferred from one point to another, such as shown in Figure A.6.1.1.

A.6.1.3 AC ratings are not suitable for dc applications. Not all overcurrent protective devices (OCPDs) are suitable for dc. Circuit breakers and/or fuses should be listed and labeled for their dc rating.

A.6.2.2 See ANSI/UL 1008, *Standard for Safety Transfer Switch Equipment*.

A.6.2.4.4 Authorized, trained personnel should be available and familiar with manual operation of the transfer switch and should be capable of determining the adequacy of the alternate source of power prior to manual transfer.

A.6.2.4.5 The timer is intended to allow the preferred source of power to stabilize before retransfer of the load.

A.6.4.1 Consideration should be given to the effect that load interruption could have on the load during maintenance and service of the transfer switch.

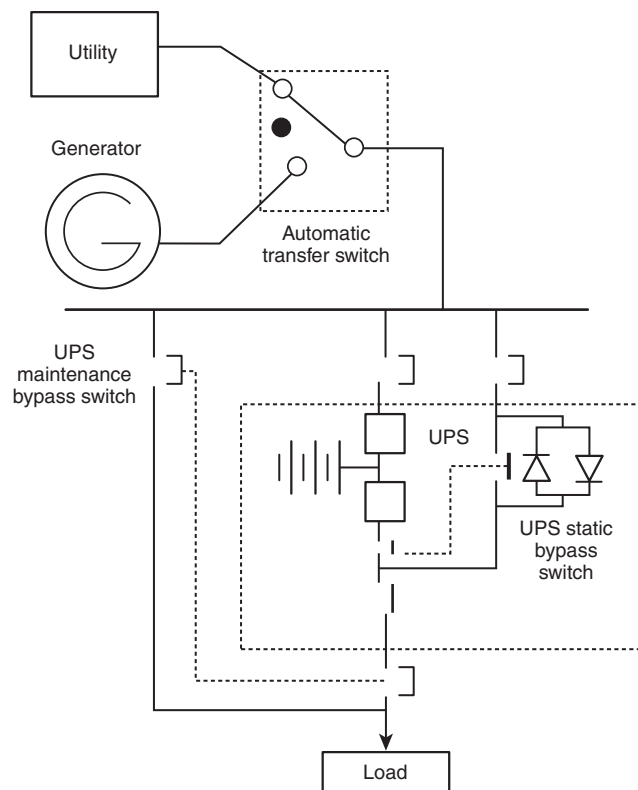

FIGURE A.6.1.1 Simplified One-Line SEPSS Switching Points.

A.6.5.1 It is extremely important that the various overcurrent devices be coordinated to protect against cascading operation on short-circuit faults. Primary consideration also should be given to prevent overloading of equipment by limiting the possibilities of large current inrushes due to instantaneous reestablishment of connections to heavy loads.

A.7.2.1 Separate rooms might be necessary for battery banks for the following reasons:

- (1) Possibility of corrosion
- (2) Ventilation for hazardous gas accumulation
- (3) Service requirements

A.7.3.3.1 Battery rooms frequently house vented lead-acid (VLA) or nickel-cadmium (NiCd) batteries that evaporate electrolyte gas into the battery space, thereby requiring periodic water replenishment. Valve regulated lead-acid (VRLA) batteries, by contrast, vent immeasurable amounts of flammable gas under normal conditions, but they can also vent significant amounts of gas under certain failure modes such as thermal runaway. Battery manufacturers can provide guidance on the rate of gassing. All batteries require some ventilation.

A.7.4.5 Consideration should be given to the location of the emergency conversion equipment (ECE), both as it relates to the building structure and to the effects of an earthquake.

All emergency power equipment support or sub-support systems should be designed and constructed so that they can withstand anticipated static or dynamic seismic forces, or both, in any direction, with the minimum force value used being equal to the equipment weight.

Bolts, anchors, hangers, braces, and other restraining devices should be provided to limit earthquake-generated differential movements between the ECE nonstructural equipment and the building structure. However, the degree of isolation necessary for vibration and acoustical control of the ECE and other equipment should be maintained.

Suspended items such as piping, conduit, ducts, and other auxiliary equipment related to the emergency power supply system (EPSS) should be braced in two directions to resist swaying and excessive movement resulting from seismic ground motion.

Battery racks for ECE and electrical items or related auxiliaries, or both, should be designed to resist internal damage and damage at the equipment supports resulting from seismic ground motion.

Battery racks should be capable of withstanding seismic forces in any direction equal to the supported weight. Batteries should be restrained to their support to prevent vibration damage, and electrical interconnections should be provided with adequate slack to accommodate all relative deflections.

A.7.6.3 Any component of an SEPSS that has failed — not just battery components — should be replaced. If elements of the system have failed and been replaced, the SEPSS should be retested to ensure proper performance before being put into service. If battery cells or units have been replaced, the replacement cells should be torqued, charged, and balanced in accordance with the manufacturer’s recommendations.

A.7.6.5.1 Case studies show that battery units are too unstable to get meaningful ohmic data when they are first installed. After a battery has been installed for some period of time (typi-

cally 6 months or longer), reliable baseline data can be taken. The actual stabilization time can vary depending upon a number of variables, including the number of discharge/recharge cycles that occur.

A.8.3.2 Maintenance procedures and frequency should follow those recommended by the manufacturer. In the absence of such recommendations, Table A.8.3.2 indicates suggested procedures.

A.8.4.1 The following standards should be consulted for recommendations on battery inspection, testing, and maintenance:

- (1) IEEE 450, *Recommended Practice for Maintenance, Testing, and Replacement of Vented Lead-Acid Batteries for Stationary Applications*
- (2) IEEE 1106, *Recommended Practice for Maintenance, Testing, and Replacement of Vented Nickel-Cadmium Batteries for Stationary Applications*
- (3) IEEE 1188, *Recommended Practice for Maintenance, Testing and Replacement of Valve-Regulated Lead-Acid Batteries for Stationary Applications*

For other battery chemistries, refer to the manufacturer's recommendations.

A.8.4.2 Figure A.8.4.2 provides guidance for operation and testing.

Table A.8.3.2 Suggested Maintenance Schedule for Solid-State Emergency Power Supply Systems

Item Component (as Applicable)	Procedure					Frequency
	Visual Inspection	Check	Change	Clean	Test	
Battery						
Float voltage		X				M
Cable connections		X				S
Terminals				X		Q
Electrolyte gravity					X	Q
Electrolyte level	X					M
Replace cell or battery			X			See manufacturer's instructions
ECE						
Power supply voltage		X				M
Terminals		X				S
Panel meters	X					M
Panel lamps	X					M
Circuit breakers, fuses	X	X	X	X		Every 2 years
Battery charger						
Output terminal volts		X				M
Fuses	X	X	X	X		Every 2 years
Charge current		X			X	Q
Equalize voltage		X				Q
Panel meters	X					M
Panel lamps	X					M
Load						
Load current		X				Q
Panel meters	X					M
Transfer switch						
Contacts	X					A
Test switch					X	S
Fuel cell						
Check fuel supply (pressure/quantity)	X					Q
Start up system	X					Q
Exercise load until system heats up					X	Q
Fuel supply piping	X					A
Exhaust piping	X					A
Air supply piping	X					A
Cooling system	X					A
Connectors				X		A
Fuel system pressure/leakage					X	A
Full load test					X	A
Calibrate H ₂ detector		X				A

A: Annually. M: Monthly. Q: Quarterly. S: Semiannually. X: Actions.

SEPSS MAINTENANCE SCHEDULE CHECKLIST					
Component Description	Frequency	Action Performed			Date Completed
		Yes	No	N/A	
Battery					
Check float voltage	M	<input type="checkbox"/>	<input type="checkbox"/>	<input type="checkbox"/>	_____
Check cable connections	S	<input type="checkbox"/>	<input type="checkbox"/>	<input type="checkbox"/>	_____
Clean terminals	Q	<input type="checkbox"/>	<input type="checkbox"/>	<input type="checkbox"/>	_____
Test electrolyte gravity	Q	<input type="checkbox"/>	<input type="checkbox"/>	<input type="checkbox"/>	_____
Visually inspect electrolyte level	M	<input type="checkbox"/>	<input type="checkbox"/>	<input type="checkbox"/>	_____
Visually inspect and replace cell or battery	Manufacturer's instructions	<input type="checkbox"/>	<input type="checkbox"/>	<input type="checkbox"/>	_____
ECE					
Check power supply voltage	M	<input type="checkbox"/>	<input type="checkbox"/>	<input type="checkbox"/>	_____
Check terminals	S	<input type="checkbox"/>	<input type="checkbox"/>	<input type="checkbox"/>	_____
Visually inspect panel meters	M	<input type="checkbox"/>	<input type="checkbox"/>	<input type="checkbox"/>	_____
Visually inspect panel lamps	M	<input type="checkbox"/>	<input type="checkbox"/>	<input type="checkbox"/>	_____
Visually inspect circuit breakers/fuses, check, replace, or clean	Every 2 years	<input type="checkbox"/>	<input type="checkbox"/>	<input type="checkbox"/>	_____
Battery Charger					
Check output terminal voltage	M	<input type="checkbox"/>	<input type="checkbox"/>	<input type="checkbox"/>	_____
Visually inspect, check, replace, and clean fuses	Every 2 years	<input type="checkbox"/>	<input type="checkbox"/>	<input type="checkbox"/>	_____
Test charge current	Q	<input type="checkbox"/>	<input type="checkbox"/>	<input type="checkbox"/>	_____
Check/equalize voltage	Q	<input type="checkbox"/>	<input type="checkbox"/>	<input type="checkbox"/>	_____
Visually inspect panel meters	M	<input type="checkbox"/>	<input type="checkbox"/>	<input type="checkbox"/>	_____
Check panel lamps	M	<input type="checkbox"/>	<input type="checkbox"/>	<input type="checkbox"/>	_____
Load					
Check load current	Q	<input type="checkbox"/>	<input type="checkbox"/>	<input type="checkbox"/>	_____
Check panel meters	M	<input type="checkbox"/>	<input type="checkbox"/>	<input type="checkbox"/>	_____
Transfer Switch					
Visually inspect contacts	A	<input type="checkbox"/>	<input type="checkbox"/>	<input type="checkbox"/>	_____
Verify test switch	S	<input type="checkbox"/>	<input type="checkbox"/>	<input type="checkbox"/>	_____
Measure and Record Values:					
	Date			Date	
Output AC Volts					
Frequency in Hz	_____	Charge Current		_____	
Load in amperes	_____	Prior to ac failure		_____	
		5 minutes after failure		_____	
DC Voltage					
Prior to ac failure	_____	Meters		_____	
1 minute after ac failure	_____	Panel lamps		_____	
5 minutes after restoring ac input	_____	Load circuit breakers		_____	
Battery Wet Lead-Acid					
For each battery	_____	Bus bars/cables of battery systems		_____	
Measure gravity	_____				
Check electrolyte level	_____				
M: Monthly. Q: Quarterly. S: Semiannually. A: Annually.					
Test performed by: _____ Date: ____ / ____ / _____					
© 2018 National Fire Protection Association					
NFPA 111					

▲ FIGURE A.8.4.2 Stored-Energy Emergency Power Supply System Operation and Suggested Testing Log.

Annex B Diagram of SEPSS Versus EPSS Use of Stored-Energy System

This annex is not a part of the requirements of this NFPA document but is included for informational purposes only.

▲ B.1 Use of Stored-Energy System. Figure B.1(a) through Figure B.1(d) show an uninterruptible power supply (UPS) being used in different functions.

Figure B.1(a) distinguishes the use of a stored-energy system as an SEPSS from a stored-energy system being supplied from an EPSS.

Figure B.1(b) shows a UPS being used as a stored-energy emergency power supply system (SEPSS), which is fully within the scope of this standard.

Figure B.1(c) shows a UPS being used as a bridge (also known as an auxiliary power unit) in combination with a generator emergency power supply (EPS), which is within the scope of NFPA 110. A bridge UPS is optional within NFPA 111, unless it is required for an emergency power supply that takes longer than 10 seconds to start. A bridge's stored energy (e.g., battery) does not have the same reserve time as the EPS that it supports. However, because it is a component in an emergency power supply system, it is inspected and tested as part of the EPSS.

Figure B.1(d) shows a UPS being used as an optional standby power system where life safety does not depend on the performance of the system. As such, it is outside the scope of this standard.

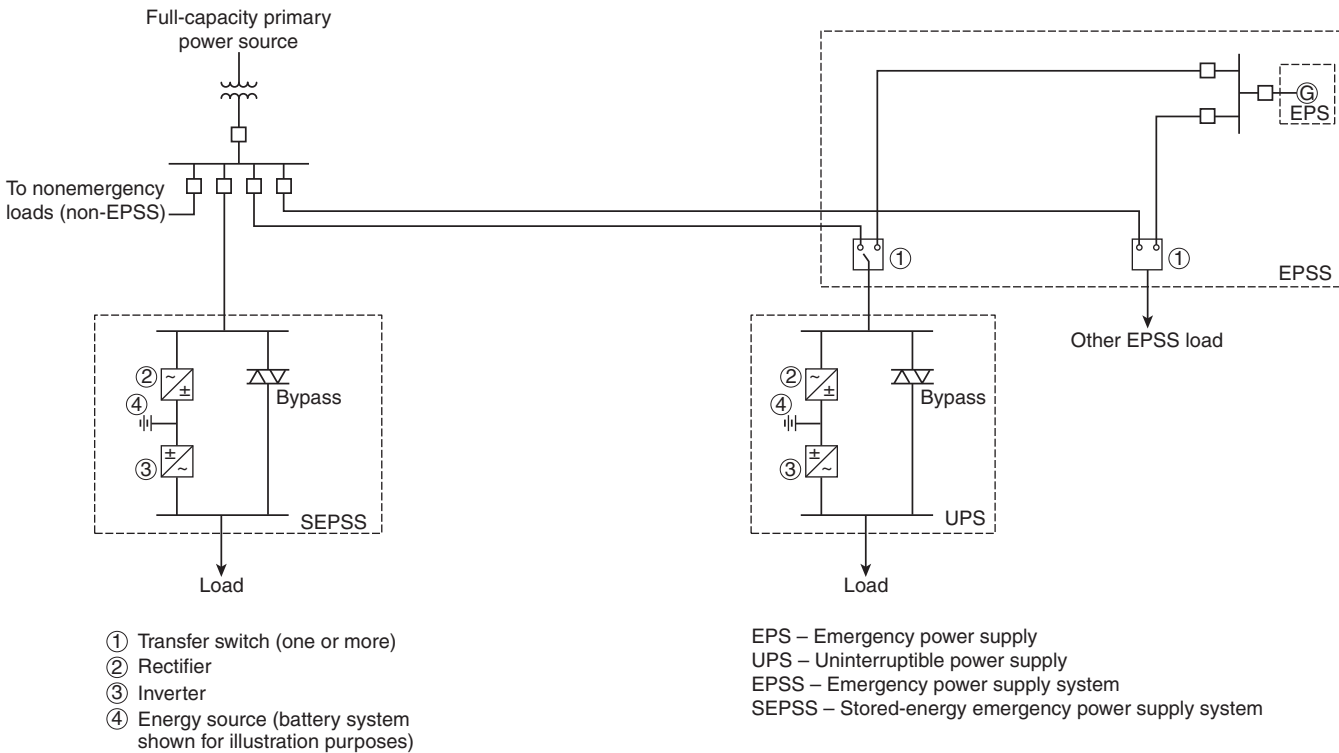

▲ FIGURE B.1(a) Stored-Energy System Serving as SEPSS (Shown on Left) and as Equipment Supplied Through an EPSS (Shown on Right).

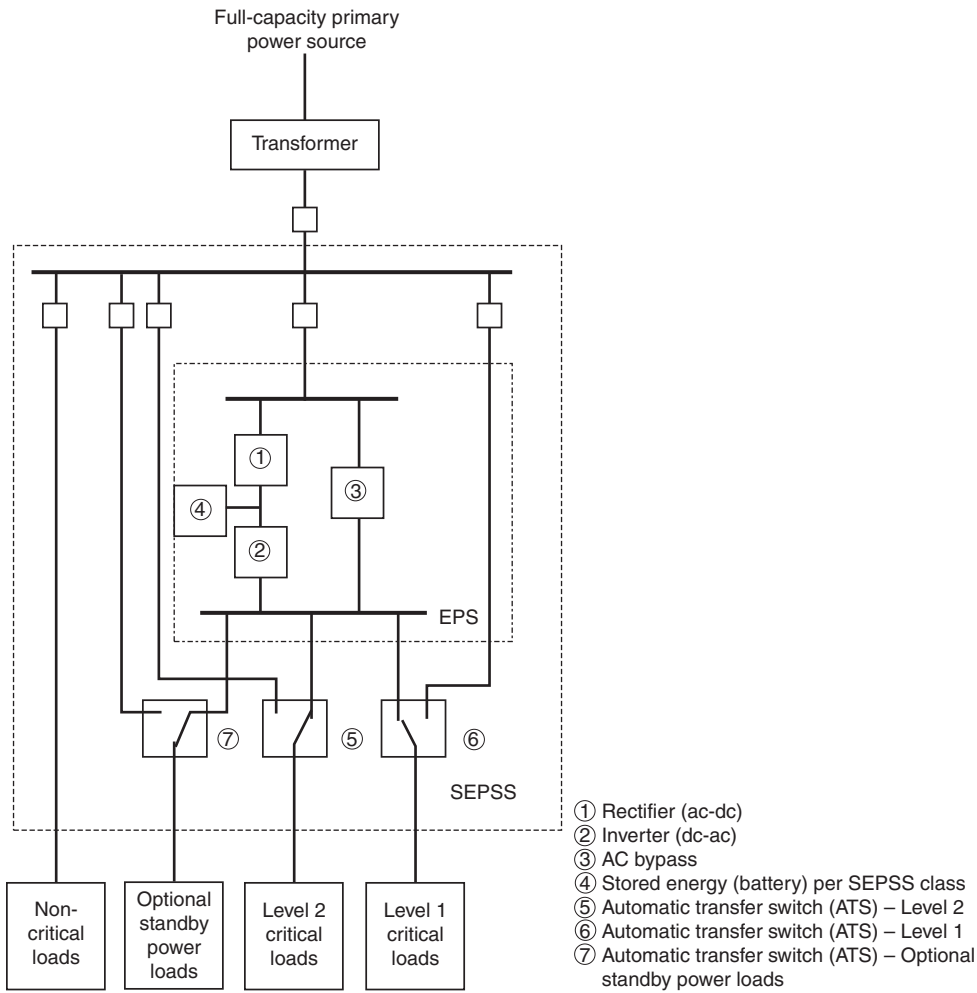

▲ FIGURE B.1(b) Simplified Diagram Showing a Stored-Energy Emergency Power Supply System (SEPSS).

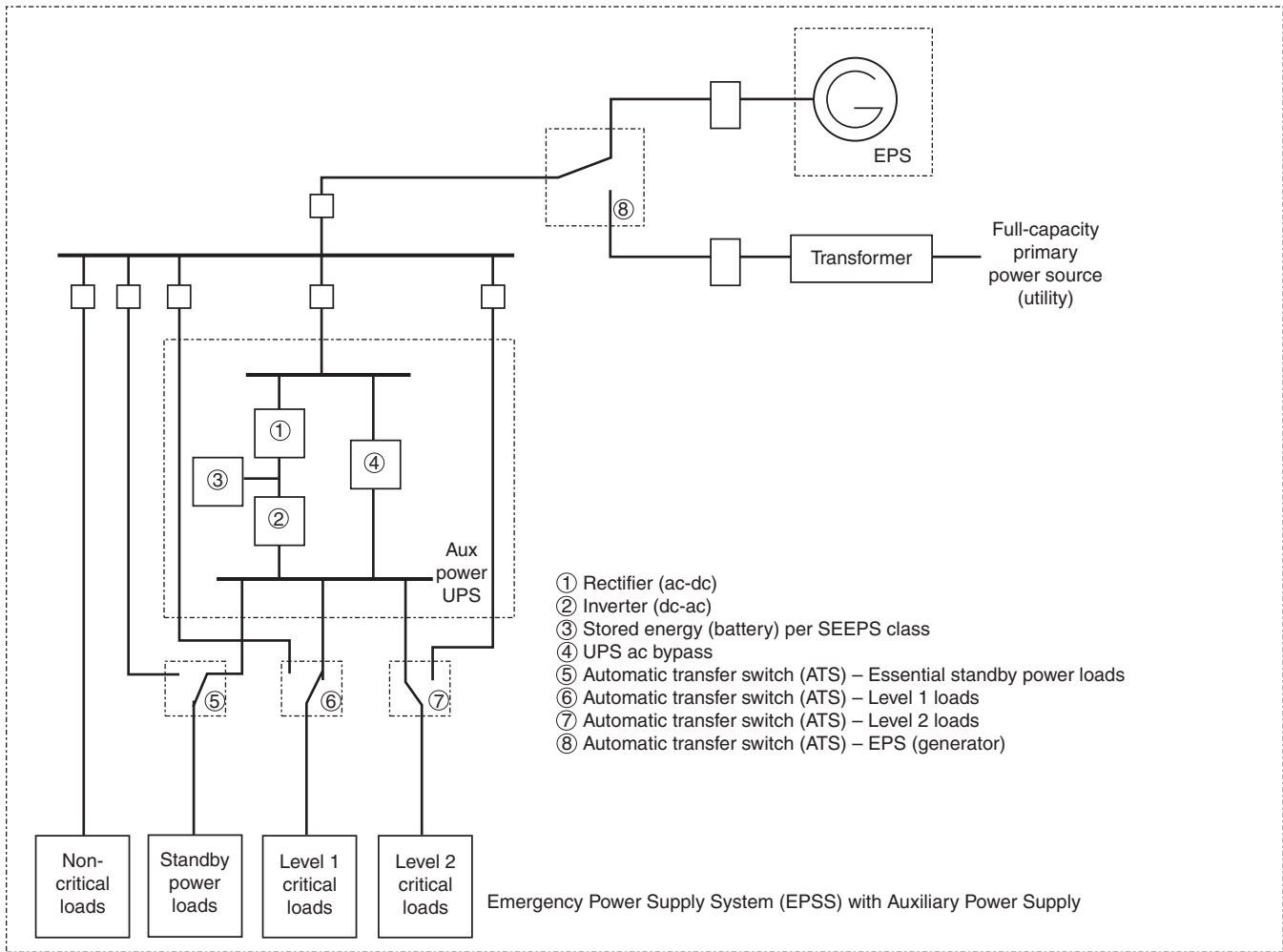

▲ FIGURE B.1(c) Simplified Diagram Showing a UPS Used as a Bridge (a.k.a. Auxiliary Power Unit) Within an Emergency Power Supply System (EPSS).

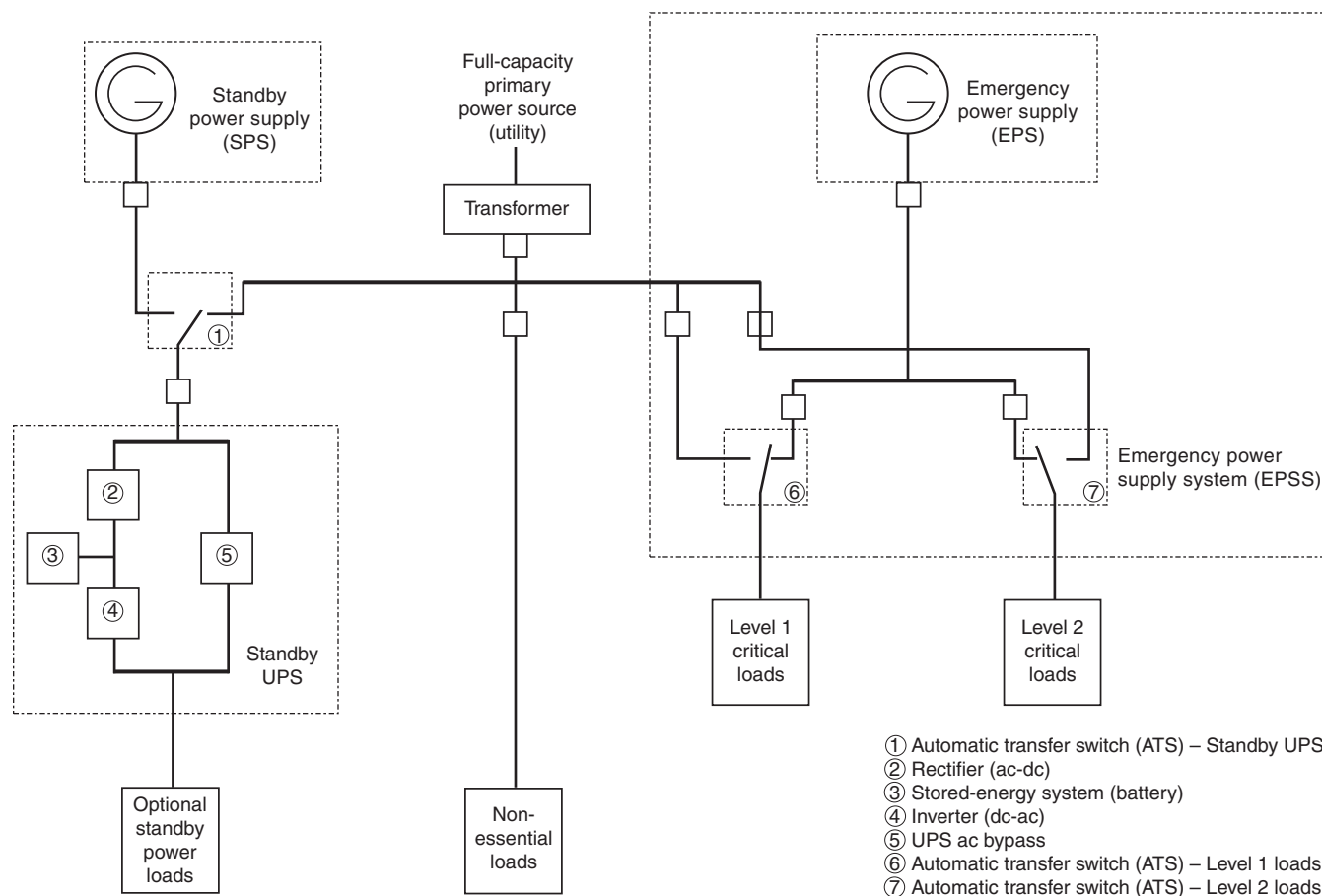

▲ FIGURE B.1(d) Simplified Diagram for an Emergency Power Supply System (EPSS) and a Standby UPS.

Annex C Informational References

C.1 Referenced Publications. The documents or portions thereof listed in this annex are referenced within the informational sections of this standard and are not part of the requirements of this document unless also listed in Chapter 2 for other reasons.

C.1.1 NFPA Publications. National Fire Protection Association, 1 Batterymarch Park, Quincy, MA 02169-7471.

NFPA 70®, *National Electrical Code*®, 2017 edition.

NFPA 99, *Health Care Facilities Code*, 2018 edition.

NFPA 101®, *Life Safety Code*®, 2018 edition.

NFPA 110, *Standard for Emergency and Standby Power Systems*, 2016 edition.

C.1.2 Other Publications.

C.1.2.1 IEC Publications. International Electrotechnical Commission, 3, rue de Varembe, P.O. Box 131, CH-1211 Geneva 20, Switzerland.

IEC 62040-3, *Uninterruptible Power Systems (UPS)-Part 3: Method of Specifying the Performance and Test Requirements*, 2011.

C.1.2.2 IEEE Publications. IEEE, Three Park Avenue, 17th Floor, New York, NY 10016-5997.

IEEE 450, *Recommended Practice for Maintenance, Testing, and Replacement of Vented Lead-Acid Batteries for Stationary Applications*, 2010.

IEEE 1106, *Recommended Practice for Maintenance, Testing, and Replacement of Vented Nickel-Cadmium Batteries for Stationary Applications*, 2015.

IEEE 1188, *Recommended Practice for Maintenance, Testing and Replacement of Valve-Regulated Lead-Acid Batteries for Stationary Applications*, 2005, Amendment 1, 2014.

C.1.2.3 NEMA Publications. National Electrical Manufacturers Association, 1300 North 17th Street, Suite 900, Arlington, VA 22209.

ANSI/NEMA C84.1, *American National Standard for Electric Power Systems and Equipment — Voltage Ratings (60 Hertz)*, 2011.

C.1.2.4 UL Publications. UL LLC, 333 Pfingsten Road, Northbrook, IL 60062-2096.

ANSI/UL 1008, *Standard for Safety Transfer Switch Equipment*, 2014.

C.2 Informational References. The following documents or portions thereof are listed here as informational resources only. They are not a part of the requirements of this document.

C.2.1 NFPA Publications. National Fire Protection Association, 1 Batterymarch Park, Quincy, MA 02169-7471.

NFPA 70B, *Recommended Practice for Electrical Equipment Maintenance*, 2013 edition.

Δ C.2.2 IEEE Publications. IEEE, Three Park Avenue, 17th Floor, New York, NY 10016-5997.

IEEE 446, *Recommended Practice for Emergency and Standby Power Systems for Industrial and Commercial Applications*, 1995, reaffirmed 2000.

IEEE 484, *Recommended Practice for Installation Design and Installation of Vented Lead-Acid Batteries for Stationary Applications*, 2002, reaffirmed 2008.

IEEE 485, *Recommended Practice for Sizing Lead-Acid Batteries for Stationary Applications*, 2010.

IEEE 944, *Recommended Practice for the Application and Testing of Uninterruptible Power Supplies for Power Generating Systems*, 1996. (Available only in electronic format.)

C.3 References for Extracts in Informational Sections.

NFPA 1, *Fire Code*, 2018 edition.

Index

Copyright © 2018 National Fire Protection Association. All Rights Reserved.

The copyright in this index is separate and distinct from the copyright in the document that it indexes. The licensing provisions set forth for the document are not applicable to this index. This index may not be reproduced in whole or in part by any means without the express written permission of NFPA.

- A-**
- Administration**, Chap. 1
 Application, 1.3
 Equivalency, 1.4
 Function, 1.5
 Purpose, 1.2
 Scope, 1.1
 Exclusions, 1.1.4
- Approved**
 Definition, 3.2.1, A.3.2.1
- Authority Having Jurisdiction (AHJ)**
 Definition, 3.2.2, A.3.2.2
- B-**
- Battery**
 Definition, 3.3.1
 Lead-Acid (LA) Cell
 Definition, 3.3.1.1, A.3.3.1.1
 Nickel-Cadmium (NiCd) Cell
 Definition, 3.3.1.2
 Nickel-Metal Hydride (NiMH) Cell
 Definition, 3.3.1.3
- Bridging System**
 Definition, 3.3.2, A.3.3.2
- C-**
- Classification of Stored-Energy Emergency Power Supply Systems (SEPSS)**, Chap. 4
 Category, 4.4
 Class, 4.3, A.4.3
 General, 4.1, A.4.1
 Level, 4.5, A.4.5
 Type, 4.2
- D-**
- Definitions**, Chap. 3
- Diagram of SEPSS Versus EPSS Use of Stored-Energy System**, Annex B
 Use of Stored-Energy System, B.1
- E-**
- Electrochemical Energy Storage Device**
 Definition, 3.3.3, A.3.3.3
- Emergency Power Supply**
 Definition, 3.3.4
- Emergency Power Supply System (EPSS)**
 Definition, 3.3.5
 Stored-Energy Emergency Power Supply System (SEPSS)
 Definition, 3.3.5.1
- Emergency Power Supply: Energy Sources, Convertors, Inverters, and Accessories**, Chap. 5
- Energy Conversion Equipment (ECE) — General, 5.2
 Bridging Systems, 5.2.1, A.5.2.1
 Capacity, 5.2.8
 Class, 5.2.8.1
 Stored-Energy Recovery, 5.2.8.2
 Class, 5.2.4
 Humidity, 5.2.7, A.5.2.7
 Level, 5.2.3
 Mechanical Inertia Systems, 5.2.2
 Output, 5.2.5
 Temperature, 5.2.6
- Energy Sources, 5.1
 Battery Systems, 5.1.1
 Battery Installation, 5.1.1.3
 Battery System Electrolyte, 5.1.1.2
 Battery Types, 5.1.1.1, A.5.1.1.1
 Mechanical Inertia Systems, 5.1.2, A.5.1.2
- Instrumentation, 5.3
 Annunciation, 5.3.3, A.5.3.3
 Indicators, 5.3.2
 Instruments, 5.3.1
- Energy Conversion Equipment (ECE)**
 Definition, 3.3.6
- Explanatory Material**, Annex A
- I-**
- Informational References**, Annex C
- Installation and Environmental Considerations**, Chap. 7
 Distribution, 7.5
 General, 7.1
 Heating, Cooling, Ventilating, and Humidity Control, 7.3
 Ventilation, 7.3.3
 Installation Acceptance, 7.6
 Baseline Measurement, 7.6.5
 Location, 7.2
 SEPSS Equipment, 7.2.3
 Protection, 7.4
 Seismic Risk, 7.4.5, A.7.4.5
- Internal Ohmic Measurement**
 Definition, 3.3.7
- L-**
- Labeled**
 Definition, 3.2.3
- Listed**
 Definition, 3.2.4, A.3.2.4
- P-**
- Power Supply**
 Definition, 3.3.8

Emergency Power Supply (EPS)

Definition, 3.3.8.1, A.3.3.8.1

Uninterruptible Power Supply (UPS)

Definition, 3.3.8.2, A.3.3.8.2

-R-

Referenced Publications, Chap. 2

Routine Maintenance and Operational Testing, Chap. 8

General, 8.1

Maintenance and Operational Testing, 8.3

Reproducible Records, 8.3.3

Manuals, Special Tools, and Spare Parts, 8.2

Operational Inspection and Testing, 8.4

Load Testing, 8.4.3

-S-

Shall

Definition, 3.2.5

Should

Definition, 3.2.6

Standard

Definition, 3.2.7

-T-

Transfer Switch

Automatic Transfer Switch (ATS)

Definition, 3.3.9.1

Definition, 3.3.9

Nonautomatic Transfer Switch

Definition, 3.3.9.2

Transfer Switches and Protection, Chap. 6

Bypass Switches, 6.4

Bypass Switch Classification, 6.4.3

Bypass Switch Rating, 6.4.2

Isolation, 6.4.1, A.6.4.1

General, 6.1

Load Switching (Load Shedding), 6.3

General, 6.3.1

Operation, 6.3.3

Transfer Switch Rating, 6.3.2

Protection, 6.5

Accessibility, 6.5.3

General, 6.5.1, A.6.5.1

Overcurrent Protective Device Rating, 6.5.2

Transfer Switches, 6.2

Automatic Transfer Switch (ATS) Features, 6.2.4

General, 6.2.4.1

Interlocking, 6.2.4.3

Manual Operation, 6.2.4.4, A.6.2.4.4

Source Monitoring, 6.2.4.2

Test Switch, 6.2.4.6

Time Delay on Retransfer to Preferred Source, 6.2.4.5,
A.6.2.4.5

General, 6.2.1

Nonautomatic Transfer Switch Features, 6.2.5

General, 6.2.5.1

Indication of Switch Position, 6.2.5.3

Interlocking, 6.2.5.2

Switch Capacity, 6.2.2, A.6.2.2

Transfer Switch Classification, 6.2.3

Sequence of Events for the Standards Development Process

Once the current edition is published, a Standard is opened for Public Input.

Step 1 – Input Stage

- Input accepted from the public or other committees for consideration to develop the First Draft
- Technical Committee holds First Draft Meeting to revise Standard (23 weeks); Technical Committee(s) with Correlating Committee (10 weeks)
- Technical Committee ballots on First Draft (12 weeks); Technical Committee(s) with Correlating Committee (11 weeks)
- Correlating Committee First Draft Meeting (9 weeks)
- Correlating Committee ballots on First Draft (5 weeks)
- First Draft Report posted on the document information page

Step 2 – Comment Stage

- Public Comments accepted on First Draft (10 weeks) following posting of First Draft Report
- If Standard does not receive Public Comments and the Technical Committee chooses not to hold a Second Draft meeting, the Standard becomes a Consent Standard and is sent directly to the Standards Council for issuance (see Step 4) or
- Technical Committee holds Second Draft Meeting (21 weeks); Technical Committee(s) with Correlating Committee (7 weeks)
- Technical Committee ballots on Second Draft (11 weeks); Technical Committee(s) with Correlating Committee (10 weeks)
- Correlating Committee Second Draft Meeting (9 weeks)
- Correlating Committee ballots on Second Draft (8 weeks)
- Second Draft Report posted on the document information page

Step 3 – NFPA Technical Meeting

- Notice of Intent to Make a Motion (NITMAM) accepted (5 weeks) following the posting of Second Draft Report
- NITMAMs are reviewed and valid motions are certified by the Motions Committee for presentation at the NFPA Technical Meeting
- NFPA membership meets each June at the NFPA Technical Meeting to act on Standards with “Certified Amending Motions” (certified NITMAMs)
- Committee(s) vote on any successful amendments to the Technical Committee Reports made by the NFPA membership at the NFPA Technical Meeting

Step 4 – Council Appeals and Issuance of Standard

- Notification of intent to file an appeal to the Standards Council on Technical Meeting action must be filed within 20 days of the NFPA Technical Meeting
- Standards Council decides, based on all evidence, whether to issue the standard or to take other action

Notes:

1. Time periods are approximate; refer to published schedules for actual dates.
2. Annual revision cycle documents with certified amending motions take approximately 101 weeks to complete.
3. Fall revision cycle documents receiving certified amending motions take approximately 141 weeks to complete.

Committee Membership Classifications^{1,2,3,4}

The following classifications apply to Committee members and represent their principal interest in the activity of the Committee.

1. M *Manufacturer*: A representative of a maker or marketer of a product, assembly, or system, or portion thereof, that is affected by the standard.
2. U *User*: A representative of an entity that is subject to the provisions of the standard or that voluntarily uses the standard.
3. IM *Installer/Maintainer*: A representative of an entity that is in the business of installing or maintaining a product, assembly, or system affected by the standard.
4. L *Labor*: A labor representative or employee concerned with safety in the workplace.
5. RT *Applied Research/Testing Laboratory*: A representative of an independent testing laboratory or independent applied research organization that promulgates and/or enforces standards.
6. E *Enforcing Authority*: A representative of an agency or an organization that promulgates and/or enforces standards.
7. I *Insurance*: A representative of an insurance company, broker, agent, bureau, or inspection agency.
8. C *Consumer*: A person who is or represents the ultimate purchaser of a product, system, or service affected by the standard, but who is not included in (2).
9. SE *Special Expert*: A person not representing (1) through (8) and who has special expertise in the scope of the standard or portion thereof.

NOTE 1: “Standard” connotes code, standard, recommended practice, or guide.

NOTE 2: A representative includes an employee.

NOTE 3: While these classifications will be used by the Standards Council to achieve a balance for Technical Committees, the Standards Council may determine that new classifications of member or unique interests need representation in order to foster the best possible Committee deliberations on any project. In this connection, the Standards Council may make such appointments as it deems appropriate in the public interest, such as the classification of “Utilities” in the National Electrical Code Committee.

NOTE 4: Representatives of subsidiaries of any group are generally considered to have the same classification as the parent organization.

Submitting Public Input / Public Comment Through the Online Submission System

Soon after the current edition is published, a Standard is open for Public Input.

Before accessing the Online Submission System, you must first sign in at www.nfpa.org. *Note: You will be asked to sign-in or create a free online account with NFPA before using this system:*

- a. Click on Sign In at the upper right side of the page.
- b. Under the Codes and Standards heading, click on the “List of NFPA Codes & Standards,” and then select your document from the list or use one of the search features.

OR

- a. Go directly to your specific document information page by typing the convenient shortcut link of www.nfpa.org/document# (Example: NFPA 921 would be www.nfpa.org/921). Sign in at the upper right side of the page.

To begin your Public Input, select the link “The next edition of this standard is now open for Public Input” located on the About tab, Current & Prior Editions tab, and the Next Edition tab. Alternatively, the Next Edition tab includes a link to Submit Public Input online.

At this point, the NFPA Standards Development Site will open showing details for the document you have selected. This “Document Home” page site includes an explanatory introduction, information on the current document phase and closing date, a left-hand navigation panel that includes useful links, a document Table of Contents, and icons at the top you can click for Help when using the site. The Help icons and navigation panel will be visible except when you are actually in the process of creating a Public Input.

Once the First Draft Report becomes available there is a Public Comment period during which anyone may submit a Public Comment on the First Draft. Any objections or further related changes to the content of the First Draft must be submitted at the Comment stage.

To submit a Public Comment you may access the online submission system utilizing the same steps as previously explained for the submission of Public Input.

For further information on submitting public input and public comments, go to: <http://www.nfpa.org/publicinput>.

Other Resources Available on the Document Information Pages

About tab: View general document and subject-related information.

Current & Prior Editions tab: Research current and previous edition information on a Standard.

Next Edition tab: Follow the committee’s progress in the processing of a Standard in its next revision cycle.

Technical Committee tab: View current committee member rosters or apply to a committee.

Technical Questions tab: For members and Public Sector Officials/AHJs to submit questions about codes and standards to NFPA staff. Our Technical Questions Service provides a convenient way to receive timely and consistent technical assistance when you need to know more about NFPA codes and standards relevant to your work. Responses are provided by NFPA staff on an informal basis.

Products & Training tab: List of NFPA’s publications and training available for purchase.

Information on the NFPA Standards Development Process

I. Applicable Regulations. The primary rules governing the processing of NFPA standards (codes, standards, recommended practices, and guides) are the NFPA *Regulations Governing the Development of NFPA Standards (Regs)*. Other applicable rules include NFPA *Bylaws*, NFPA *Technical Meeting Convention Rules*, NFPA *Guide for the Conduct of Participants in the NFPA Standards Development Process*, and the NFPA *Regulations Governing Petitions to the Board of Directors from Decisions of the Standards Council*. Most of these rules and regulations are contained in the *NFPA Standards Directory*. For copies of the *Directory*, contact Codes and Standards Administration at NFPA Headquarters; all these documents are also available on the NFPA website at “www.nfpa.org.”

The following is general information on the NFPA process. All participants, however, should refer to the actual rules and regulations for a full understanding of this process and for the criteria that govern participation.

II. Technical Committee Report. The Technical Committee Report is defined as “the Report of the responsible Committee(s), in accordance with the Regulations, in preparation of a new or revised NFPA Standard.” The Technical Committee Report is in two parts and consists of the First Draft Report and the Second Draft Report. (See *Regs* at Section 1.4.)

III. Step 1: First Draft Report. The First Draft Report is defined as “Part one of the Technical Committee Report, which documents the Input Stage.” The First Draft Report consists of the First Draft, Public Input, Committee Input, Committee and Correlating Committee Statements, Correlating Notes, and Ballot Statements. (See *Regs* at 4.2.5.2 and Section 4.3.) Any objection to an action in the First Draft Report must be raised through the filing of an appropriate Comment for consideration in the Second Draft Report or the objection will be considered resolved. [See *Regs* at 4.3.1(b).]

IV. Step 2: Second Draft Report. The Second Draft Report is defined as “Part two of the Technical Committee Report, which documents the Comment Stage.” The Second Draft Report consists of the Second Draft, Public Comments with corresponding Committee Actions and Committee Statements, Correlating Notes and their respective Committee Statements, Committee Comments, Correlating Revisions, and Ballot Statements. (See *Regs* at 4.2.5.2 and Section 4.4.) The First Draft Report and the Second Draft Report together constitute the Technical Committee Report. Any outstanding objection following the Second Draft Report must be raised through an appropriate Amending Motion at the NFPA Technical Meeting or the objection will be considered resolved. [See *Regs* at 4.4.1(b).]

V. Step 3a: Action at NFPA Technical Meeting. Following the publication of the Second Draft Report, there is a period during which those wishing to make proper Amending Motions on the Technical Committee Reports must signal their intention by submitting a Notice of Intent to Make a Motion (NITMAM). (See *Regs* at 4.5.2.) Standards that receive notice of proper Amending Motions (Certified Amending Motions) will be presented for action at the annual June NFPA Technical Meeting. At the meeting, the NFPA membership can consider and act on these Certified Amending Motions as well as Follow-up Amending Motions, that is, motions that become necessary as a result of a previous successful Amending Motion. (See 4.5.3.2 through 4.5.3.6 and Table 1, Columns 1-3 of *Regs* for a summary of the available Amending Motions and who may make them.) Any outstanding objection following action at an NFPA Technical Meeting (and any further Technical Committee consideration following successful Amending Motions, see *Regs* at 4.5.3.7 through 4.6.5.3) must be raised through an appeal to the Standards Council or it will be considered to be resolved.

VI. Step 3b: Documents Forwarded Directly to the Council. Where no NITMAM is received and certified in accordance with the Technical Meeting Convention Rules, the standard is forwarded directly to the Standards Council for action on issuance. Objections are deemed to be resolved for these documents. (See *Regs* at 4.5.2.5.)

VII. Step 4a: Council Appeals. Anyone can appeal to the Standards Council concerning procedural or substantive matters related to the development, content, or issuance of any document of the NFPA or on matters within the purview of the authority of the Council, as established by the Bylaws and as determined by the Board of Directors. Such appeals must be in written form and filed with the Secretary of the Standards Council (see *Regs* at Section 1.6). Time constraints for filing an appeal must be in accordance with 1.6.2 of the *Regs*. Objections are deemed to be resolved if not pursued at this level.

VIII. Step 4b: Document Issuance. The Standards Council is the issuer of all documents (see Article 8 of *Bylaws*). The Council acts on the issuance of a document presented for action at an NFPA Technical Meeting within 75 days from the date of the recommendation from the NFPA Technical Meeting, unless this period is extended by the Council (see *Regs* at 4.7.2). For documents forwarded directly to the Standards Council, the Council acts on the issuance of the document at its next scheduled meeting, or at such other meeting as the Council may determine (see *Regs* at 4.5.2.5 and 4.7.4).

IX. Petitions to the Board of Directors. The Standards Council has been delegated the responsibility for the administration of the codes and standards development process and the issuance of documents. However, where extraordinary circumstances requiring the intervention of the Board of Directors exist, the Board of Directors may take any action necessary to fulfill its obligations to preserve the integrity of the codes and standards development process and to protect the interests of the NFPA. The rules for petitioning the Board of Directors can be found in the *Regulations Governing Petitions to the Board of Directors from Decisions of the Standards Council* and in Section 1.7 of the *Regs*.

X. For More Information. The program for the NFPA Technical Meeting (as well as the NFPA website as information becomes available) should be consulted for the date on which each report scheduled for consideration at the meeting will be presented. To view the First Draft Report and Second Draft Report as well as information on NFPA rules and for up-to-date information on schedules and deadlines for processing NFPA documents, check the NFPA website (www.nfpa.org/docinfo) or contact NFPA Codes & Standards Administration at (617) 984-7246.



Xchange™

The place to connect online with your fire, electrical, and life safety peers

Have a question about the code or standard you're reading now?

NFPA Xchange™ can help!

NFPA Xchange™ brings together over 30,000 professionals worldwide, asking and answering each other's questions, sharing ideas, and discussing the issues impacting your industry today.

NFPA Xchange™ is free to join and offers:

- A robust collection of previously asked and answered questions to search
- Access to thousands of peers for problem-solving and on-the-job advice
- NFPA blogs, white papers, and webinars in one convenient place

NFPA members also enjoy Xchange™ **Members Only**, the online space for technical questions* answered by NFPA staff, exclusive NFPA live events, and premier access to curated content.

Join NFPA Xchange™ TODAY!

www.nfpa.org/xchange

Xchange Today. Safer Tomorrow.

*For the full terms of use, please visit nfpa.org/standard_items/terms-of-use#xchange. NFPA® is a registered trademark of the National Fire Protection Association, Quincy, MA 02169.