

NFPA[®]

105

**Standard for
Smoke Door Assemblies and
Other Opening Protectives**

2019



IMPORTANT NOTICES AND DISCLAIMERS CONCERNING NFPA® STANDARDS

NOTICE AND DISCLAIMER OF LIABILITY CONCERNING THE USE OF NFPA STANDARDS

NFPA® codes, standards, recommended practices, and guides (“NFPA Standards”), of which the document contained herein is one, are developed through a consensus standards development process approved by the American National Standards Institute. This process brings together volunteers representing varied viewpoints and interests to achieve consensus on fire and other safety issues. While the NFPA administers the process and establishes rules to promote fairness in the development of consensus, it does not independently test, evaluate, or verify the accuracy of any information or the soundness of any judgments contained in NFPA Standards.

The NFPA disclaims liability for any personal injury, property, or other damages of any nature whatsoever, whether special, indirect, consequential or compensatory, directly or indirectly resulting from the publication, use of, or reliance on NFPA Standards. The NFPA also makes no guaranty or warranty as to the accuracy or completeness of any information published herein.

In issuing and making NFPA Standards available, the NFPA is not undertaking to render professional or other services for or on behalf of any person or entity. Nor is the NFPA undertaking to perform any duty owed by any person or entity to someone else. Anyone using this document should rely on his or her own independent judgment or, as appropriate, seek the advice of a competent professional in determining the exercise of reasonable care in any given circumstances.

The NFPA has no power, nor does it undertake, to police or enforce compliance with the contents of NFPA Standards. Nor does the NFPA list, certify, test, or inspect products, designs, or installations for compliance with this document. Any certification or other statement of compliance with the requirements of this document shall not be attributable to the NFPA and is solely the responsibility of the certifier or maker of the statement.

REVISION SYMBOLS IDENTIFYING CHANGES FROM THE PREVIOUS EDITION

Text revisions are shaded. A **Δ** before a section number indicates that words within that section were deleted and a **Δ** to the left of a table or figure number indicates a revision to an existing table or figure. When a chapter was heavily revised, the entire chapter is marked throughout with the **Δ** symbol. Where one or more sections were deleted, a **•** is placed between the remaining sections. Chapters, annexes, sections, figures, and tables that are new are indicated with an **N**.

Note that these indicators are a guide. Rearrangement of sections may not be captured in the markup, but users can view complete revision details in the First and Second Draft Reports located in the archived revision information section of each code at www.nfpa.org/docinfo. Any subsequent changes from the NFPA Technical Meeting, Tentative Interim Amendments, and Errata are also located there.

REMINDER: UPDATING OF NFPA STANDARDS

Users of NFPA codes, standards, recommended practices, and guides (“NFPA Standards”) should be aware that NFPA Standards may be amended from time to time through the issuance of a Tentative Interim Amendment (TIA) or corrected by Errata. An official NFPA Standard at any point in time consists of the current edition of the document together with any TIAs and Errata then in effect.

To determine whether an NFPA Standard has been amended through the issuance of Tentative Interim Amendments or corrected by Errata, go to www.nfpa.org/docinfo to choose from the list of NFPA Standards or use the search feature to select the NFPA Standard number (e.g., NFPA 13). The document information page provides up-to-date document-specific information as well as postings of all existing TIAs and Errata. It also includes the option to register for an “Alert” feature to receive an automatic email notification when new updates and other information are posted regarding the document.

IMPORTANT NOTICES AND DISCLAIMERS CONCERNING NFPA® STANDARDS

ADDITIONAL NOTICES AND DISCLAIMERS

Updating of NFPA Standards

Users of NFPA codes, standards, recommended practices, and guides (“NFPA Standards”) should be aware that these documents may be superseded at any time by the issuance of new editions or may be amended from time to time through the issuance of Tentative Interim Amendments or corrected by Errata. An official NFPA Standard at any point in time consists of the current edition of the document together with any Tentative Interim Amendments and any Errata then in effect. In order to determine whether a given document is the current edition and whether it has been amended through the issuance of Tentative Interim Amendments or corrected through the issuance of Errata, consult appropriate NFPA publications such as the National Fire Codes® Subscription Service, visit the NFPA website at www.nfpa.org, or contact the NFPA at the address listed below.

Interpretations of NFPA Standards

A statement, written or oral, that is not processed in accordance with Section 6 of the Regulations Governing the Development of NFPA Standards shall not be considered the official position of NFPA or any of its Committees and shall not be considered to be, nor be relied upon as, a Formal Interpretation.

Patents

The NFPA does not take any position with respect to the validity of any patent rights referenced in, related to, or asserted in connection with an NFPA Standard. The users of NFPA Standards bear the sole responsibility for determining the validity of any such patent rights, as well as the risk of infringement of such rights, and the NFPA disclaims liability for the infringement of any patent resulting from the use of or reliance on NFPA Standards.

NFPA adheres to the policy of the American National Standards Institute (ANSI) regarding the inclusion of patents in American National Standards (“the ANSI Patent Policy”), and hereby gives the following notice pursuant to that policy:

NOTICE: The user’s attention is called to the possibility that compliance with an NFPA Standard may require use of an invention covered by patent rights. NFPA takes no position as to the validity of any such patent rights or as to whether such patent rights constitute or include essential patent claims under the ANSI Patent Policy. If, in connection with the ANSI Patent Policy, a patent holder has filed a statement of willingness to grant licenses under these rights on reasonable and nondiscriminatory terms and conditions to applicants desiring to obtain such a license, copies of such filed statements can be obtained, on request, from NFPA. For further information, contact the NFPA at the address listed below.

Law and Regulations

Users of NFPA Standards should consult applicable federal, state, and local laws and regulations. NFPA does not, by the publication of its codes, standards, recommended practices, and guides, intend to urge action that is not in compliance with applicable laws, and these documents may not be construed as doing so.

Copyrights

NFPA Standards are copyrighted. They are made available for a wide variety of both public and private uses. These include both use, by reference, in laws and regulations, and use in private self-regulation, standardization, and the promotion of safe practices and methods. By making these documents available for use and adoption by public authorities and private users, the NFPA does not waive any rights in copyright to these documents.

Use of NFPA Standards for regulatory purposes should be accomplished through adoption by reference. The term “adoption by reference” means the citing of title, edition, and publishing information only. Any deletions, additions, and changes desired by the adopting authority should be noted separately in the adopting instrument. In order to assist NFPA in following the uses made of its documents, adopting authorities are requested to notify the NFPA (Attention: Secretary, Standards Council) in writing of such use. For technical assistance and questions concerning adoption of NFPA Standards, contact NFPA at the address below.

For Further Information

All questions or other communications relating to NFPA Standards and all requests for information on NFPA procedures governing its codes and standards development process, including information on the procedures for requesting Formal Interpretations, for proposing Tentative Interim Amendments, and for proposing revisions to NFPA standards during regular revision cycles, should be sent to NFPA headquarters, addressed to the attention of the Secretary, Standards Council, NFPA, 1 Batterymarch Park, P.O. Box 9101, Quincy, MA 02269-9101; email: stds_admin@nfpa.org.

For more information about NFPA, visit the NFPA website at www.nfpa.org. All NFPA codes and standards can be viewed at no cost at www.nfpa.org/docinfo.

Copyright © 2018 National Fire Protection Association®. All Rights Reserved.

NFPA® 105

Standard for

Smoke Door Assemblies and Other Opening Protectives

2019 Edition

This edition of NFPA 105, *Standard for Smoke Door Assemblies and Other Opening Protectives*, was prepared by the Technical Committee on Fire Doors and Windows. It was issued by the Standards Council on May 4, 2018, with an effective date of May 24, 2018, and supersedes all previous editions.

This edition of NFPA 105 was approved as an American National Standard on May 24, 2018.

Origin and Development of NFPA 105

This publication is the result of a multiyear project by the Technical Committee on Fire Doors and Windows and is based on the acknowledgment that smoke is the principal killer in destructive fires. Historically, fire doors have been permitted to have such clearances and deflections as would permit the passage of relatively great quantities of smoke. Those fire doors, when properly installed, have proven to be adequate barriers against the passage of fire, but improvement was needed to protect against the passage of smoke.

The first (1985) edition of NFPA 105 was a recommended practice and introduced parameters for door performance that would limit smoke spread through a door opening.

The third (1993) edition incorporated new information recognizing that smoke control doors in buildings protected by automatic sprinklers would have substantially lower pressures created by a potential fire.

The 1999 edition included modifications to address the pressure differentials caused by stack effect in elevator hoistways.

The 2003 edition incorporated editorial and formatting updates to comply with the *Manual of Style for NFPA Technical Committee Documents*, as well as formatting requirements for converting from a recommended practice to a standard. The 2003 edition also included significant modifications to Chapter 4 on installation and testing requirements and to Chapter 5 on maintenance requirements. Annex A contained a considerable amount of new and updated information.

The 2007 edition expanded the scope of the document to include smoke dampers. The title of the document was revised, and new chapters on the installation, inspection, testing, and maintenance of smoke dampers were provided. Other technical changes addressed the retention of maintenance records for smoke door assemblies.

The 2010 edition included modifications to smoke damper inspection and testing requirements. The title of the document was also revised.

The 2013 edition added references to NFPA 80, *Standard for Fire Doors and Other Opening Protectives*, for the inspection and testing requirements of smoke door assemblies. Other technical changes addressed the inspection and testing of smoke dampers and labeling of smoke damper access panels.

The 2016 edition of NFPA 105 represented a significant expansion and update of the document. For consistency with NFPA 80 and to allow for a more user-friendly document, a new chapter, Chapter 6, Swinging Doors, containing provisions specific to the installation of side-hinged and pivoted swinging smoke door assemblies was added. Provisions for smoke dampers were moved to a new Chapter 7, Installation, Testing, and Maintenance of Smoke Dampers. Additional chapters will be added in future editions of NFPA 105 to address requirements for other specific types of smoke doors and opening protectives. Also for consistency with NFPA 80, the inspection, testing, and maintenance provisions for smoke door assemblies in Chapter 5 were expanded to address multiple types of smoke doors as well as three types of testing — operational, acceptance, and periodic. A new chapter, Chapter 8, Smoke Protective Curtain Assemblies, addressed the installation, inspection,

testing, and maintenance of smoke-protective curtain assemblies used to protect vertical openings. Significant technical changes were also added regarding the acceptance and periodic testing of smoke dampers. Finally, new definitions for *qualified person* and *smoke-protective curtain assembly* were added, along with updates to referenced publications to maintain the requirements and application of NFPA 105 current with industry trends and practices.

Changes for the 2019 edition of NFPA 105 focus primarily on the provisions for smoke dampers. New 7.3.1.2 requires smoke damper manufacturer's installation and maintenance instructions be maintained on site for new smoke damper installations. Chapter 7 also continues to update the requirements for the inspection, testing, and maintenance of smoke dampers with the addition of new 7.6.3.3 on a remote inspection method. A new 7.6.2.3 clarifies application of inspection requirements for single inaccessible dampers. Section 7.5 contains new requirements to further clarify and update the process for smoke damper acceptance testing. A new opening protective is addressed by new Chapter 9, which applies to smoke-protective curtain assemblies for hoistways. A new definition is added to Chapter 3 to describe a smoke-protective curtain assembly for hoistways. Referenced publications and extracted sections have been updated as needed.

Technical Committee on Fire Doors and Windows

Keith E. Pardoe, Chair

Pardoe Consulting LLC, VA [SE]

- Chad E. Beebe**, ASHE - AHA, WA [U]
Bruce G. Campbell, JENSEN HUGHES, TX [SE]
William Conner, Bill Conner Associates LLC, IL [SE]
 Rep. American Society of Theater Consultants
Richard L. Cravy, Ruskin Company, MO [M]
David Dawdy, Cornell Iron Works, Inc., PA [IM]
 Rep. International Door Association
Cheryl L. Domnitch, Won Door Corporation, CA [M]
Luc Durand, Saskatoon Fire Department, Canada [E]
Marty Gissel, Greenheck Fan, WI [M]
Jerrold S. Gorrell, Theatre Safety Programs, AZ [IM]
 Rep. U.S. Institute for Theatre Technology, Inc.
Jeffrey E. Gould, FM Global, MA [I]
Anne M. Guglielmo, Liberty Mutual Insurance, IL [I]
Steven C. Hahn, Lawrence Roll-Up Doors, Inc., CA [M]
 Rep. Door & Access Systems Manufacturers Assn. International
Harold D. Hicks, Jr., Atlantic Code Consultants, PA [SE]
Thomas R. Janicak, Ceco Door Products, IL [M]
 Rep. Steel Door Institute
William E. Koffel, Koffel Associates, Inc., MD [M]
 Rep. Glazing Industry Code Committee
Keith Lippincott, University of Maryland, MD [E]
Vernon J. Patton, First Energy Corporation, OH [U]
- James S. Peterkin**, TLC Engineering, PA [U]
 Rep. NFPA Health Care Section
Michael Puls, Intertek, WI [RT]
 Rep. Intertek Testing Services
Steven P. Reynolds, The Peelle Company Ltd., Canada [M]
 Rep. National Elevator Industry Inc.
Ronald Rispoli, Entergy Corporation, AR [U]
Thomas M. Rubright, William S. Trimble Company, Inc., TN [M]
 Rep. Door and Hardware Institute
Michael L. Savage, Sr., City of Rio Rancho, NM [E]
Steve Schreiber, Masonite, TN [M]
 Rep. Window & Door Manufacturers Association
Duane R. Smith, National Energy Management Institute Inc., IN [M]
Robert W. Stubblefield, AREVA NP Inc., TX [SE]
Michael Tierney, Kellen Company, CT [M]
 Rep. Builders Hardware Manufacturers Association
Garrett S. Tom, International Fire Door Inspector Association, NV [U]
Yunyong Pock Utiskul, Exponent, Inc., MD [SE]
Luke C. Woods, UL LLC, MA [RT]
Anthony W. Yuen, Berkeley Fire Department, CA [E]

Alternates

- Joel Bonnell**, Raynor Garage Doors, IL [M]
 (Alt. to Steven C. Hahn)
Kevin L. Brinkman, National Elevator Industry, Inc., IL [M]
 (Alt. to Steven P. Reynolds)
Daniel J. Culhane, Wenger Corporation, MN [IM]
 (Alt. to Jerrold S. Gorrell)
Michael F. Daly, FM Global, MA [I]
 (Alt. to Jeffrey E. Gould)
Thomas Resciniti Demont, Technical Services Inc., PA [U]
 (Alt. to Garrett S. Tom)
William F. Guffey, University of Maryland, MD [E]
 (Alt. to Keith Lippincott)
John Hamilton, National Energy Management Institute, MN [SE]
 (Voting alt.)
Daisy R. Harington, City Of Saskatoon Building Standards, Canada [E]
 (Alt. to Luc Durand)
Justin Scott Hendricks, Intertek, WI [RT]
 (Alt. to Michael Puls)
- Daniel Hibbs**, Eggers Industries, WI [M]
 (Alt. to Steve Schreiber)
Kent Maune, Ruskin Manufacturing, MO [M]
 (Alt. to Richard L. Cravy)
Alfredo M. Ramirez, UL LLC, IL [RT]
 (Alt. to Luke C. Woods)
Kurt A. Roeper, ASSA ABLOY, CT [M]
 (Alt. to Thomas R. Janicak)
Garry Stewart, The Doorman Service Company, Inc., WA [IM]
 (Alt. to David Dawdy)
David V. Tomecek, JENSEN HUGHES, CO [SE]
 (Alt. to Bruce G. Campbell)
Rodney Weaver, Door and Hardware Institute, NC [M]
 (Alt. to Thomas M. Rubright)
John Woestman, Kellen Company, IA [M]
 (Alt. to Michael Tierney)
Thomas Zarembo, Roetzel and Andress, OH [M]
 (Alt. to William E. Koffel)

Nonvoting

Joseph N. Saino, Memphis, TN [SE]
 (Member Emeritus)

Kristin Bigda, NFPA Staff Liaison

This list represents the membership at the time the Committee was balloted on the final text of this edition. Since that time, changes in the membership may have occurred. A key to classifications is found at the back of the document.

NOTE: Membership on a committee shall not in and of itself constitute an endorsement of the Association or any document developed by the committee on which the member serves.

Committee Scope: This Committee shall have primary responsibility for documents on the installation and maintenance of fire doors, windows, shutters, and other equipment used to restrict the spread of fire, including arrangements for automatic operation in case of fire. This includes installation to protect buildings against external fire and to restrict the spread of fire within buildings. Vault and record room doors are covered by the Technical Committee on Record Protection.

Contents

Chapter 1 Administration	105- 6	Chapter 7 Installation, Testing, and Maintenance of Smoke Dampers	105- 12
1.1 Scope.	105- 6	7.1 General.	105- 12
1.2 Purpose.	105- 6	7.2 Definitions. (Reserved)	105- 12
1.3 Application.	105- 6	7.3 Installation.	105- 12
1.4 Retroactivity.	105- 6	7.4 Operational Test.	105- 13
1.5 Equivalency.	105- 6	7.5 Acceptance Testing.	105- 13
Chapter 2 Referenced Publications	105- 6	7.6 Periodic Testing.	105- 13
2.1 General.	105- 6	7.7 Maintenance.	105- 14
2.2 NFPA Publications.	105- 6	7.8 Field Modifications.	105- 14
2.3 Other Publications.	105- 6	Chapter 8 Smoke-Protective Curtain Assemblies	105- 14
2.4 References for Extracts in Mandatory Sections.	105- 7	8.1 General.	105- 14
Chapter 3 Definitions	105- 7	8.2 Mounting of Smoke-Protective Curtain Assemblies.	105- 14
3.1 General.	105- 7	8.3 Assembly Components.	105- 14
3.2 NFPA Official Definitions.	105- 7	8.4 Power Operators.	105- 14
3.3 General Definitions.	105- 7	8.5 Installation.	105- 14
Chapter 4 General Requirements	105- 7	8.6 Inspection, Testing, and Maintenance.	105- 14
4.1 General.	105- 7	8.7 Acceptance Testing.	105- 14
4.2 Test Specimen.	105- 7	8.8 Closing Devices.	105- 15
4.3 Air Leakage Test.	105- 8	8.9 Periodic Inspection and Testing.	105- 15
4.4 Labeling.	105- 8	8.10 Maintenance.	105- 15
4.5 Installation.	105- 8	Chapter 9 Smoke-Protective Curtain Assemblies for Hoistways	105- 15
Chapter 5 Inspection, Testing, and Maintenance of Smoke Door Assemblies	105- 8	9.1 General.	105- 15
5.1 General.	105- 8	9.2 Mounting of Smoke-Protective Curtain Assemblies for Hoistways.	105- 15
5.2 Inspections and Testing.	105- 8	9.3 Assembly Components.	105- 15
5.3 Performance-Based Option.	105- 10	9.4 Power Operators.	105- 15
5.4 Maintenance.	105- 10	9.5 Installation.	105- 15
5.5 Prevention of Door Blockage.	105- 10	9.6 Inspection, Testing, and Maintenance.	105- 16
5.6 Maintenance of Closing Mechanisms.	105- 10	Annex A Explanatory Material	105- 17
Chapter 6 Swinging Doors	105- 10	Annex B Performance-Based Option for the Inspection, Testing, and Maintenance of Smoke Door Assemblies	105- 23
6.1 General.	105- 10	Annex C Informational References	105- 24
6.2 Swinging Doors with Fire Protection Ratings. ...	105- 10	Index	105- 25
6.3 Swinging Doors Without Fire Protection Ratings.	105- 10		
6.4 Vision Panels in Doors.	105- 12		
6.5 Glazing in Sidelight and Transom Light Frames.	105- 12		
6.6 Side Panel and Transom Panel Frames.	105- 12		
6.7 Gasketing and Astragals.	105- 12		

NFPA 105**Standard for****Smoke Door Assemblies and Other Opening
Protectives**

2019 Edition

IMPORTANT NOTE: This NFPA document is made available for use subject to important notices and legal disclaimers. These notices and disclaimers appear in all publications containing this document and may be found under the heading “Important Notices and Disclaimers Concerning NFPA Standards.” They can also be viewed at www.nfpa.org/disclaimers or obtained on request from NFPA.

UPDATES, ALERTS, AND FUTURE EDITIONS: New editions of NFPA codes, standards, recommended practices, and guides (i.e., NFPA Standards) are released on scheduled revision cycles. This edition may be superseded by a later one, or it may be amended outside of its scheduled revision cycle through the issuance of Tentative Interim Amendments (TIAs). An official NFPA Standard at any point in time consists of the current edition of the document, together with all TIAs and Errata in effect. To verify that this document is the current edition or to determine if it has been amended by TIAs or Errata, please consult the National Fire Codes® Subscription Service or the “List of NFPA Codes & Standards” at www.nfpa.org/docinfo. In addition to TIAs and Errata, the document information pages also include the option to sign up for alerts for individual documents and to be involved in the development of the next edition.

NOTICE: An asterisk (*) following the number or letter designating a paragraph indicates that explanatory material on the paragraph can be found in Annex A.

A reference in brackets [] following a section or paragraph indicates material that has been extracted from another NFPA document. As an aid to the user, the complete title and edition of the source documents for extracts in mandatory sections of the document are given in Chapter 2 and those for extracts in informational sections are given in Annex C. Extracted text may be edited for consistency and style and may include the revision of internal paragraph references and other references as appropriate. Requests for interpretations or revisions of extracted text shall be sent to the technical committee responsible for the source document.

Information on referenced publications can be found in Chapter 2 and Annex C.

Chapter 1 Administration

1.1 Scope. This standard shall prescribe minimum requirements for smoke door assemblies for use in providing safety to life and protection of property from smoke.

1.2* Purpose. The purpose of this standard shall be to provide a means to restrict the movement of smoke through door assemblies in order to maintain a tenable environment.

1.3* Application. This standard shall regulate the installation, maintenance, and testing of smoke door assemblies.

1.3.1* This standard shall regulate smoke door assemblies that are intended to restrict the passage of smoke at temperatures up to 400°F (204°C).

1.3.2* This standard shall not regulate elevator hoistway doors.

1.4 Retroactivity. This standard is based on product and engineering practices recognized as acceptable at the date of issue. Therefore, the provisions of this standard are not intended to be applied retroactively to installations that were in compliance at the time of installation.

1.5 Equivalency.

1.5.1 This standard shall not prohibit the development of new, modified, or improved devices that meet the intent of these requirements. It shall be the responsibility of the manufacturer to furnish the information necessary to update the requirements pertaining to such new and improved devices.

1.5.2 For devices not described in this standard, the authority having jurisdiction (AHJ) shall request descriptive information from manufacturers that is provided by a testing laboratory concerning acceptable methods for satisfactory field installation based on fire tests and engineering studies for operation and maintenance considerations, where applicable.

Chapter 2 Referenced Publications

2.1 General. The documents or portions thereof listed in this chapter are referenced within this standard and shall be considered part of the requirements of this document.

2.2 NFPA Publications. National Fire Protection Association, 1 Batterymarch Park, Quincy, MA 02169-7471.

NFPA 72®, *National Fire Alarm and Signaling Code*®, 2019 edition.

NFPA 80, *Standard for Fire Doors and Other Opening Protectives*, 2019 edition.

NFPA 92, *Standard for Smoke Control Systems*, 2018 edition.

NFPA 252, *Standard Methods of Fire Tests of Door Assemblies*, 2017 edition.

2.3 Other Publications.

2.3.1 ASME Publications. American Society of Mechanical Engineers, Two Park Avenue, New York, NY 10016-5990.

ASME A17.1/CSA B44, *Safety Code for Elevators and Escalators*, 2016.

2.3.2 BHMA Publications. Builders Hardware Manufacturers Association, 355 Lexington Avenue, 15th floor, New York, NY 10017.

ANSI/BHMA A156.1, *Standard for Butts and Hinges*, 2013.

ANSI/BHMA A156.4, *Door Controls – Closers, Grade 1*, 2013.

2.3.3 UL Publications. UL LLC, 333 Pfingsten Road, Northbrook, IL 60062-2096.

ANSI/UL 10B, *Standard for Fire Tests of Door Assemblies*, 2008.

ANSI/UL 10C, *Standard for Positive Pressure Fire Tests of Door Assemblies*, 2016.

ANSI/UL 1784, *Air Leakage Tests of Door Assemblies*, 2015.

2.3.4 Other Publications.

Merriam-Webster’s Collegiate Dictionary, 11th edition, Merriam-Webster, Inc., Springfield, MA, 2003.

2.4 References for Extracts in Mandatory Sections.

NFPA 72®, *National Fire Alarm and Signaling Code*®, 2019 edition.

NFPA 80, *Standard for Fire Doors and Other Opening Protectives*, 2019 edition.

NFPA 92, *Standard for Smoke Control Systems*, 2018 edition.

Chapter 3 Definitions

3.1 General. The definitions contained in this chapter shall apply to the terms used in this standard. Where terms are not defined in this chapter or within another chapter, they shall be defined using their ordinarily accepted meanings within the context in which they are used. *Merriam-Webster's Collegiate Dictionary*, 11th edition, shall be the source for the ordinarily accepted meaning.

3.2 NFPA Official Definitions.

3.2.1* Approved. Acceptable to the authority having jurisdiction.

3.2.2* Authority Having Jurisdiction (AHJ). An organization, office, or individual responsible for enforcing the requirements of a code or standard, or for approving equipment, materials, an installation, or a procedure.

3.2.3 Labeled. Equipment or materials to which has been attached a label, symbol, or other identifying mark of an organization that is acceptable to the authority having jurisdiction and concerned with product evaluation, that maintains periodic inspection of production of labeled equipment or materials, and by whose labeling the manufacturer indicates compliance with appropriate standards or performance in a specified manner.

3.2.4* Listed. Equipment, materials, or services included in a list published by an organization that is acceptable to the authority having jurisdiction and concerned with evaluation of products or services, that maintains periodic inspection of production of listed equipment or materials or periodic evaluation of services, and whose listing states that either the equipment, material, or service meets appropriate designated standards or has been tested and found suitable for a specified purpose.

3.2.5 Shall. Indicates a mandatory requirement.

3.2.6 Should. Indicates a recommendation or that which is advised but not required.

3.2.7 Standard. An NFPA Standard, the main text of which contains only mandatory provisions using the word “shall” to indicate requirements and that is in a form generally suitable for mandatory reference by another standard or code or for adoption into law. Nonmandatory provisions are not to be considered a part of the requirements of a standard and shall be located in an appendix, annex, footnote, informational note, or other means as permitted in the NFPA Manuals of Style. When used in a generic sense, such as in the phrase “standards development process” or “standards development activities,” the term “standards” includes all NFPA Standards, including Codes, Standards, Recommended Practices, and Guides.

3.3 General Definitions.

3.3.1 Qualified Person. A person who, by possession of a recognized degree, certificate, professional standing, or skill, and who, by knowledge, training, and experience, has demonstrated the ability to deal with the subject matter, the work, or the project.

3.3.2 Smoke Damper. A device within an air distribution system to control the movement of smoke.

3.3.2.1 Combination Fire/Smoke Damper. A device that meets both the fire damper and smoke damper requirements.

3.3.3 Smoke Door. The door component of a smoke door assembly.

3.3.4 Smoke Door Assembly. Any combination of a door, frame, hardware, and any other accessories that together restrict smoke movement through door openings by limiting the amount of air that can pass through the assembly.

3.3.5 Smoke-Protective Curtain Assembly. Assembly typically consisting of a fabric curtain, bottom bar, guides, coil, operating and closing system.

N 3.3.6 Smoke-Protective Curtain Assembly for Hoistways. An assembly typically consisting of a housing, smoke-protective curtain, side retention system, bottom bar, and closing device that deploys the curtain to protect a hoistway opening.

3.3.7 Temperature.

3.3.7.1 Ambient Temperature. An assumed air temperature at the exposed face of the door at or near 75°F (24°C).

3.3.7.2* Elevated Temperature. An assumed air temperature at the exposed face of the door in excess of ambient temperature.

3.3.8* Tenable Environment. An environment in which smoke and heat are limited or otherwise restricted to maintain the impact on occupants to a level that is not life threatening. [92, 2018]

Chapter 4 General Requirements

4.1 General. This chapter shall cover the requirements for testing of smoke door assemblies.

4.2 Test Specimen.

4.2.1 The size of the door to be tested shall be 3 ft × 7 ft (0.9 m × 2.1 m) for a single side-hinged swinging door, and 6 ft × 7 ft (1.8 m × 2.1 m) for a pair of side-hinged swinging doors and all other doors, or shall be representative of the full range of smoke door production for that type of construction as determined by the testing laboratory.

4.2.2 For the air leakage test, fire door assemblies shall be installed in accordance with NFPA 80.

4.2.2.1 Clearances for doors without a fire protection rating shall be in accordance with the manufacturer's specifications.

4.2.3* Doors intended for installation in frames containing transoms, side lights, or side panels shall be tested with such frames.

4.2.4 Specimens of door assemblies shall be tested as they are intended to be installed.

4.3 Air Leakage Test.

4.3.1* Smoke door assemblies shall have an air leakage rating not greater than 3 ft³/min/ft² (0.9 m³/min/m²) of door opening when tested in accordance with ANSI/UL 1784, *Air Leakage Tests of Door Assemblies*.

4.3.2* Smoke door assemblies intended for installation where pressurization is provided to control smoke movement shall not have an artificial bottom seal installed during the test.

4.3.3* Where data exists to verify that tests at ambient temperature result in a higher leakage rate, additional tests at elevated temperature shall not be required.

4.3.4* The test shall be required to be performed only at a pressure differential of 0.1, 0.2, or 0.3 ± 0.005 in. of water (25, 50, or 75 ± 1.25 Pa).

4.4* Labeling. Smoke door assemblies shall bear an “S” label indicating a maximum air leakage rate of 3 ft³/min/ft² (0.9 m³/min/m²) and the tested pressure differential of 0.1, 0.2, or 0.3 in. of water (25, 50, or 75 Pa).

4.5 Installation.

4.5.1 Smoke doors shall be self-closing or automatic closing in accordance with NFPA 80.

4.5.2 Automatic closing smoke door assemblies shall be activated by smoke detection installed in accordance with *NFPA 72*.

4.5.3 Devices for the release of smoke doors shall be permitted to be part of an overall system, such as a fire alarm or an automatic extinguishing system, that shall release the door and shall be installed and tested in accordance with *NFPA 72*.

4.5.4 The opening between the bottom edge of the smoke door and the sill when the door is in the closed position shall not be required to be provided with a means to seal the opening.

4.5.4.1 Smoke door assemblies installed where pressurization is provided to restrict smoke movement shall be required to have a bottom seal.

4.5.5 Louvers shall not be installed in smoke door assemblies unless otherwise tested and listed.

Chapter 5 Inspection, Testing, and Maintenance of Smoke Door Assemblies

5.1 General.

5.1.1 Application.

5.1.1.1 This chapter shall cover the inspection, testing, and maintenance of smoke door assemblies.

5.1.1.2 The requirements of this chapter shall apply to new and existing installations.

5.1.2 Removal of Smoke Doors. Where a smoke door no longer functions as an opening or is removed and not replaced, the opening shall be filled with construction to maintain the smoke partition or smoke barrier properties of the wall.

5.1.3 Operability.

5.1.3.1* Smoke doors shall be operable at all times.

5.1.3.2 Smoke doors shall be kept closed or arranged for automatic closing, unless otherwise permitted.

5.1.3.3 Where required, the doors shall be positively latched.

5.1.4 Replacement. Where it is necessary to replace all or part of a smoke door assembly, replacement components shall be installed to meet the requirements of this standard and the manufacturer's instructions.

5.1.5 Field Modifications.

5.1.5.1 Field modifications of fire-rated smoke door assemblies shall be made in accordance with NFPA 80.

5.1.5.2* Field modifications of smoke door assemblies without fire ratings shall be permitted to be made, provided the modifications are performed in accordance with the applicable requirements of this standard.

5.1.5.3 Upon completion of field modification work, smoke door assemblies shall be inspected in accordance with Section 5.2.

5.2 Inspections and Testing.

5.2.1 Upon installation, smoke door assemblies shall be inspected and tested in accordance with the following:

- (1) Fire-rated smoke door assemblies shall be inspected and tested in accordance with this standard and also in accordance with Chapter 5 of NFPA 80.
- (2) Door assemblies without fire ratings shall be inspected in accordance with the requirements of this standard.
- (3) Inspections of smoke door assemblies without fire ratings shall be permitted to be performed at the same time as inspections for door assemblies subject to inspection under NFPA 80.
- (4) All functional tests shall be conducted after the building's mechanical ventilation system has been balanced and is operating.
- (5) All functional tests shall be conducted after the closing mechanism has been adjusted for the applicable maximum allowable opening force.

5.2.2* A record of all inspections and testing shall be signed by the inspector and kept for inspection by the AHJ.

5.2.2.1 Records of the acceptance tests shall be retained for the life of the assembly.

5.2.2.2* Unless a longer period is required by NFPA 80, records shall be retained for a period of at least 3 years.

5.2.2.3* The records shall be on a medium that will survive the retention period. Paper or electronic media shall be permitted. [72:14.6.2.3]

5.2.2.4 A record of all inspections and testing shall be provided that includes, but is not limited to, the following information:

- (1) Date of inspection
- (2) Name of facility
- (3) Address of facility
- (4) Name of person(s) performing inspections and testing
- (5) Company name and address of inspecting company
- (6) Signature of inspector of record
- (7) Individual record of each inspected and tested [smoke] door assembly

- (8)* Opening identifier and location of each inspected and tested [smoke] door assembly
- (9)* Type and description of each inspected and tested [smoke] door assembly
- (10)* Verification of visual inspection and functional operation
- (11) Listing of deficiencies in accordance with 5.2.4 [80:5.2.2.4]

5.2.3 Maintenance Records.

5.2.3.1 Upon completion of maintenance, smoke door assemblies shall be inspected and tested in accordance with 5.2.4.

5.2.3.2 A record of these inspections and testing shall be made in accordance with 5.2.2.

5.2.3.3 A record of maintenance performed on existing smoke door assemblies shall be provided that includes, but is not limited to, the following information:

- (1) Date of maintenance
- (2) Name of facility
- (3) Address of facility
- (4) Name of person(s) performing maintenance
- (5) Company name and address of maintenance personnel
- (6) Signature of maintenance personnel performing the work
- (7) Individual listings of each maintained smoke door assembly
- (8) Opening identifier and location of each repaired smoke door assembly
- (9) Type and description of each repaired smoke door assembly
- (10) Description or listing of the work performed on each smoke door assembly

5.2.4* **Acceptance Testing.** Acceptance testing of smoke door assemblies shall be performed by a qualified person with knowledge and understanding of the operating components of the type of assembly subject to testing.

5.2.4.1* Before testing, a visual inspection shall be performed to identify any damaged or missing parts that can create a hazard during testing or affect operation or resetting.

5.2.4.2 Acceptance testing shall include the closing of the door by all means.

5.2.4.2.1 Acceptance testing shall be conducted after the building's mechanical ventilation system has been balanced, in accordance with 5.2.1.

5.2.4.2.2 Acceptance testing shall be conducted after the closing mechanism has been adjusted for the applicable maximum allowable opening force.

5.2.4.3 A record of these inspections and testing shall be made in accordance with 5.2.2.

5.2.4.4 Sliding Smoke Door Assemblies.

5.2.4.4.1 Smoke door assemblies shall be visually inspected from both sides to assess the overall condition of the assembly.

5.2.4.4.2 As a minimum, the following items shall be verified:

- (1) Labels on fire-rated smoke door assemblies are clearly visible and legible and bear the "S" label marking.
- (2) Door leaves without fire protection ratings comply with 6.3.1.

- (3) Door frames comply with 6.3.2.
- (4) Gasketing along the vertical edges of the door and across the top of the door and, where required, at meeting edges of pairs of doors forms a continuous seal that is not cut, notched, or otherwise modified to accommodate other hardware items.
- (5) Gasketing materials, where required, are intact and close the gaps between the door and frame to seal the door opening against the passage of smoke.
- (6) Doors installed in pressurized applications have a bottom seal, where required.
- (7) Doors equipped with bottom seals that automatically project to fully seal the gap under the door in the closed position do not interfere with the swinging of the door when retracted or the closing of the door when projected.
- (8) No open holes or breaks exist in the surfaces of either the door or the frame.
- (9) Glazing, vision light frames, and glazing beads are intact and securely fastened in place, if so equipped.
- (10) Glazing materials and vision light kits comply with Sections 6.5 and 6.6.
- (11) Glazing materials, vision light kits, and glazing beads are continuously sealed.
- (12) The door, frame, hinges, and other hardware are secured, aligned, and in working order with no visible signs of damage.
- (13) No parts are missing or broken.
- (14) Door clearances do not exceed dimensions listed in 6.3.3 when measured on the pull side of the door(s).
- (15) The self-closing device is operational; that is, the active door completely closes when operated from the full open position.
- (16) If a coordinator is installed, the inactive leaf closes before the active leaf.
- (17) Where positive latching is required, latching hardware operates and secures the door when the door is in the closed position.
- (18) Where door leaves, other than doors arranged for automatic closing, are permitted to be held open with friction door holder devices, the door holder devices comply with 6.3.6.6.

5.2.4.5 Horizontally Sliding, Vertically Sliding, and Rolling Doors.

5.2.4.5.1 Smoke door assemblies shall be visually inspected from both sides to assess the overall condition of the door assembly.

5.2.4.5.2 The following items shall be verified:

- (1) Labels are clearly visible and legible.
- (2) No open holes or breaks exist in surfaces of either the door or the frame.
- (3) Slats, endlocks, bottom bar, guide assembly, curtain entry, hood, and flame baffle are correctly installed and intact for rolling steel fire doors.
- (4) Gasketing along the perimeter of the door forms a continuous seal that is not cut, notched, or otherwise modified.
- (5) Glazing, vision light frames, and glazing beads are intact and securely fastened in place, if so equipped.
- (6) Curtain, barrel, and guides are aligned, level, plumb, and true for rolling steel fire doors.

- (7) Expansion clearance is maintained in accordance with manufacturer's listing.
- (8) Drop release arms and weights are not blocked or wedged.
- (9) Mounting and assembly bolts are intact and secured.
- (10) Attachments to jambs are with bolts, expansion anchors, or as otherwise required by the listing.
- (11) Smoke detectors, if equipped, are installed and operational.
- (12) No parts are missing or broken.
- (13)* Fusible links, if so equipped, are in the location; chain/cable, s-hooks, eyes, and so forth, are in good condition; the cable or chain is not kinked, pinched, twisted, or inflexible; and links are not painted or coated with dust or grease.
- (14) Auxiliary hardware items that interfere or prohibit operation are not installed on the door or frame.
- (15) No field modifications to the door assembly that void the label have been performed.
- (16) Doors have an average closing speed of not less than 6 in./sec (152 mm/sec) or more than 24 in./sec (610 mm/sec).

5.2.5 Periodic Inspection and Testing.

5.2.5.1 Periodic inspection and testing shall be performed not less than annually.

5.2.5.2 As a minimum, the provisions of 5.2.4 shall be included in the periodic inspection and testing procedure.

5.2.5.3 Inspection shall include an operational test for automatic-closing doors to verify that the assembly will close under fire conditions.

5.2.5.4 The assembly shall be reset after each test.

5.2.5.5 Resetting of the release mechanism shall be done in accordance with the manufacturer's instructions.

5.2.5.6 Hardware and gaskets shall be inspected annually, and any parts found to be damaged or inoperative shall be replaced without delay.

5.2.5.7 Tin-clad and Kalamein doors shall be inspected regularly for dry rot.

5.3* Performance-Based Option.

5.3.1 As an alternative means of compliance with 5.2.5, subject to the AHJ, smoke door assemblies shall be permitted to be inspected, tested, and maintained under a written performance-based program.

5.3.2 Goals established under a performance-based program shall provide assurance that the smoke door assembly will perform its intended function when exposed to fire conditions.

5.3.3 The technical justification for inspection, testing, and maintenance intervals shall be documented in writing.

5.3.4 The performance-based option shall include historical data acceptable to the AHJ.

5.4 Maintenance.

5.4.1* Repairs shall be made, and defects that could interfere with operation shall be corrected without delay.

5.4.2 Fire-rated smoke door assemblies shall also be maintained in accordance with NFPA 80.

5.4.3 Damaged glazing material shall be replaced in accordance with the applicable codes.

5.4.4 Replacement glazing material shall be installed in accordance with its individual listing, where required, and the manufacturer's listing.

5.4.5 Where holes are left in a door or frame due to changes or removal of hardware or plant-ons, the holes shall be sealed to resist the passage of smoke at ambient and elevated temperatures up to 400°F (204°C).

5.4.6 Where a smoke door, frame, or any part of its appurtenances is damaged to the extent that it could impair the door assembly's proper emergency function, the following actions shall be performed:

- (1) The door, frame, door assembly, or any parts of its appurtenances shall be replaced with parts obtained from the original manufacturer.
- (2) The door shall be tested to ensure emergency operation and closing upon completion of the repairs, in accordance with 5.2.3.

5.4.7 If repairs cannot be made with parts obtained from the original manufacturer or retrofitted, the door, the door assembly, or appurtenances shall be replaced.

5.5 Prevention of Door Blockage.

5.5.1 Door openings and the surrounding areas shall be kept clear of anything that could obstruct or interfere with the free operation and full closure of the door.

5.5.2 Blocking or wedging of doors in the open position shall be prohibited.

5.6 Maintenance of Closing Mechanisms.

5.6.1 Self-closing and automatic closing devices shall be kept in working condition at all times.

5.6.2 Care shall be taken to prevent paint accumulation on any movable parts such as, but not limited to, hinges, pivots, closer arms, and latching hardware.

Chapter 6 Swinging Doors

6.1* **General.** This chapter shall cover the installation of side-hinged and side-pivoted swinging smoke door assemblies.

6.2 **Swinging Doors with Fire Protection Ratings.** Fire door assemblies that are intended for use as smoke door assemblies shall also comply with NFPA 80.

6.3* **Swinging Doors Without Fire Protection Ratings.** Doors without fire protection ratings shall be permitted to be used as smoke door assemblies in door openings not required to be protected by fire doors.

6.3.1* **Doors.** Non-fire-rated door leaves shall be of a design that resists the passage of smoke.

6.3.1.1* Vertical edges of new composite and wood door leaves shall be square edged or beveled.

6.3.1.2 Doors installed in pairs shall be beveled or have astragals or rabbets at meeting edges.

6.3.1.3 Doors shall be flush mounted in door frames.

6.3.1.4 Dutch doors shall be permitted to be used, provided they comply with the following:

- (1) Both the upper leaf and the lower leaf are equipped with a latching device.
- (2) The meeting edges of the upper and lower leaves are equipped with an astragal or a rabbet.

6.3.1.5 Louvers and transfer grilles shall not be permitted in doors.

6.3.2 Door Frames. Door frames shall be labeled or comply with 6.3.2.1.

6.3.2.1 Where permitted by other standards, door frames shall be of steel construction or shall be of other designs that have been tested and reported by a nationally recognized testing agency in accordance with NFPA 252; ANSI/UL 10B, *Standard for Fire Tests of Door Assemblies*; or ANSI/UL 10C, *Standard for Positive Pressure Fire Tests of Door Assemblies*.

6.3.2.2* Door frames with terminated stops shall be permitted, provided the lowest portion of the terminated stops is not greater than 6 in. (152 mm) above the bottom of the frame.

6.3.2.3 Supporting Construction. Wall openings shall be constructed to readily accept the door frames.

6.3.2.4 The door frames shall be considered to be non-load bearing.

6.3.2.5 Frames shall be securely anchored to the wall construction.

6.3.3* Clearances. Doors in smoke partitions shall have clearances in accordance with NFPA 80.

6.3.3.1* Doors in smoke barriers shall close the opening, leaving only the minimum clearance necessary for proper operation. The clearance under the bottom of a new door shall be a maximum of $\frac{3}{4}$ in. (19 mm).

6.3.3.2 The maximum clearance between the bottom of side-hinged or -pivoted swinging smoke doors and the finished floor shall be not greater than $\frac{3}{4}$ in. (19 mm), unless otherwise permitted.

6.3.3.3 Where the bottom of the door is more than 38 in. (965 mm) above the finished floor, the maximum clearance under the door shall not exceed $\frac{3}{8}$ in. (10 mm).

6.3.4* Latching Hardware. Where required, smoke doors without fire protection rating shall be provided with hardware that provides positive latching.

6.3.5 Operation of Doors. Doors shall be arranged to be either self-closing or automatic closing, where required, unless otherwise exempted.

6.3.5.1* Self-Closing. Self-closing doors shall swing easily and freely and shall be equipped with a closing device that closes, the door, causing it to latch, each time the door closes.

6.3.5.2 The closing mechanism shall not have a hold-open feature.

6.3.5.3 Automatic Closing. Automatic-closing doors shall be permitted to close automatically by means of the installation of a closing device and the following:

- (1) Upon release of the hold-open mechanism, the leaf becomes self-closing.

- (2) The release device is designed so that the leaf instantly releases manually and, upon release, becomes self-closing, or the leaf can be readily closed.

- (3) The automatic releasing mechanism or medium is activated by the operation of approved smoke detectors installed in accordance with the requirements for smoke detectors for door leaf release service in NFPA 72.

- (4) Upon loss of power to the hold-open device, the hold-open mechanism is released and the door leaf becomes self-closing.

- (5) The release by means of smoke detection of one door leaf in a smokeproof enclosure or a stair enclosure results in closing all door leaves serving the enclosure.

- (6) Where required, doors properly latch upon closing.

6.3.5.4 Power-Operated Doors. Power-operated doors shall be equipped with a releasing device that automatically disconnects the power operator at the time of fire, allowing a self-closing or automatic device to close the door regardless of power failure or manual operation, provided all the following criteria are met:

- (1) The door is equipped with a means for keeping the door closed that is acceptable to the AHJ.

- (2) The device used is capable of keeping the door fully closed if a force of 5 lbf (22 N) is applied to the latch edge of swinging doors, whether or not power is applied.

6.3.6* Builders Hardware

6.3.6.1 Conventional Hinges. Conventional hinges used on doors with closing devices shall have ball bearings or anti-friction bearings and meet the requirements of ANSI/BHMA A156.1, *Standard for Butts and Hinges*.

6.3.6.1.1 Hinges shall be sized in thickness, height, and width in accordance with the hinge manufacturer's recommended guidelines.

6.3.6.1.2 Hinges shall have brass/bronze or steel base materials or be stainless steel.

6.3.6.1.3 Doors up to 60 in. (1.52 m) in height shall be provided with two hinges and an additional hinge for each additional 30 in. (0.76 m) of door height or fraction thereof.

6.3.6.1.4 The distance between hinges shall be permitted to exceed 30 in. (0.76 m).

6.3.6.1.5 Where spring hinges are used, at least two shall be provided.

6.3.6.2 Pivots. Pivots shall be in compliance with NFPA 80.

6.3.6.3 Continuous Hinges. Continuous hinges shall be in compliance with NFPA 80.

6.3.6.4* Locks and Latches. Locking and latching shall comply with NFPA 80.

6.3.6.4.1 Where panic hardware is utilized, the latching device shall not be permitted to be mechanically held in the retracted position.

6.3.6.4.2 Latching arrangements that do not provide positive latching in the normal mode shall be permitted to be used provided that, in a fire emergency, the door becomes positively latched by means of an automatic fail-safe device that is activated by an automatic fire detector. [80:6.4.4.3.3]

6.3.6.4.3 Strike plates for locks and latches on pairs of doors shall not have extended lips that prevent astragals from sealing the gap at the meeting edges of the doors.

6.3.6.5 Door-Closing Devices. Door-closing devices, other than spring hinges, shall meet the requirements of ANSI/BHMA A156.4, *Door Controls — Closers, Grade 1*.

6.3.6.5.1 Where non-fire-rated doors are permitted to be held open, the door closing device shall be permitted to have an integral friction hold-open feature that permits the door to be closed when pulled or pushed.

6.3.6.5.2 Doors arranged for automatic closing shall have a closing device that meets the requirements of 6.3.5.3.

6.3.6.6 Door Holder/Release Devices.

6.3.6.6.1 Door holder/release devices for automatic-closing doors shall be installed in accordance with the manufacturer's instructions and in conformance with the individual manufacturer's published listings.

6.3.6.6.2* Where required for non-fire-rated smoke doors without door closers, only door holder devices that release when pushed or pulled shall be permitted.

6.3.6.7* Protection Plates. Doors without fire protection rating are permitted to have non-rated, factory- or field-applied protection plates of unlimited size, unless otherwise restricted by the door or protection plate manufacturers' specifications.

6.3.6.8* Attaching Hardware to Doors and Frames. Hardware items shall be attached to doors and frames in accordance with NFPA 80.

6.4 Vision Panels in Doors.

6.4.1 Glazing materials shall be capable of resisting the passage of smoke.

6.4.2 The perimeter of the glazing material and vision panel frames shall be sealed to resist the passage of smoke at temperatures up to 400°F (204°C).

6.4.3 Vision panels in smoke doors required to have a fire protection rating shall comply with NFPA 80.

6.5 Glazing in Sidelight and Transom Light Frames.

6.5.1 Glazing materials shall be capable of resisting the passage of smoke.

6.5.2* The perimeter of the glazing material and sidelight and transom frames shall be sealed to resist the passage of smoke at temperatures up to 400°F (204°C).

6.5.3 Glazing in sidelight and transom light frames that are required to be fire rated shall comply with NFPA 80.

6.6 Side Panel and Transom Panel Frames.

6.6.1 The perimeter of fixed solid panels used in side panel and transom panel frames shall be sealed to resist the passage of smoke.

6.6.2 Removable panels shall be permitted, provided they are gasketed to resist the passage of smoke.

6.7* Gasketing and Astragals.

6.7.1 Gasketing. Where required by the door listing, the gaps between the top and vertical edges of the door and frame and

between the meeting edges of pairs of doors shall be closed with labeled gasketing material in accordance with the gasketing manufacturer's published listings.

6.7.1.1* Gasketing material shall form a continuous seal along the top and vertical edges of the doors and at meeting edges of pairs of doors.

6.7.1.2* Where mortising of doors to receive hardware items creates a void along the vertical or top edges of doors, soffit-mounted gasketing shall be required.

6.7.1.3* Where required, gaps between the bottom of the doors and the floor shall be closed with labeled gasketing in accordance with the gasketing manufacturer's published listing.

6.7.1.4 Automatic door bottoms that close the gap between the bottom of the door and the floor or threshold shall be permitted to be installed.

6.7.2 Astragals. Doors swinging in pairs, where located with a means of egress, shall not be equipped with astragals that inhibit the free use of either leaf.

Chapter 7 Installation, Testing, and Maintenance of Smoke Dampers

7.1* General. This chapter covers the requirements of the installation, testing, and maintenance of smoke dampers and combination fire and smoke dampers.

7.2 Definitions. (Reserved)

7.3 Installation.

7.3.1 Dampers.

7.3.1.1 Smoke dampers shall be installed within 24 in. (610 mm) of the partition and before any branch line or opening other than access panel and shall be installed in accordance with the manufacturer's installation instructions and the listing.

N 7.3.1.2* For new damper installations, the damper manufacturer's installation and maintenance instructions shall be maintained on-site.

7.3.1.3 Damper actuator and linkage to operate the smoke damper shall be supplied and installed at the factory.

7.3.2 Dampers equipped with fusible links and/or internal operators shall be provided with an access door that is not less than 12 in.² (7742 mm²) or provided with a removable duct section.

7.3.2.1 Dampers that are installed behind registers, diffusers, or grilles shall be serviceable by removal of these covers.

7.3.2.2 A smoke damper access panel shall be labeled with the words "Smoke Damper" in letters not less than ½ in. (13 mm) in height. External insulation shall not conceal any access panel unless there is a label attached to the insulation clearly indicating the exact location of the access panel and the insulation is installed for ease of removal or ease of removal with the access panel.

7.3.2.3 Unobstructed access shall be provided through a ceiling or wall for inspection and service of the damper's working parts.

7.3.2.4 Installation of combination fire/smoke dampers shall be in accordance with the installation of fire dampers in NFPA 80, Section 19.2.

7.3.2.5 Smoke detectors used to control smoke dampers or fire/smoke dampers shall be spaced and installed per the requirements of NFPA 72.

7.4 Operational Test.

7.4.1 Smoke and Combination Fire/Smoke Dampers. An operational test shall be conducted after the building's HVAC system has been balanced.

7.4.1.1 The test shall be adequate to determine that the damper has been installed and functions as intended.

Δ 7.4.1.2 The operational test shall be conducted under normal HVAC airflow and nonairflow conditions. The damper shall fully close under both test conditions.

7.4.1.3 The operational test shall verify that there are no obstructions to the operation of the dynamic combination damper.

7.4.1.4 The operational test shall verify that there is full and unobstructed access to the dynamic combination damper and all appurtenances.

7.4.1.5 All indicating devices shall be verified to work properly and report to the intended location.

7.4.1.6 Combination fire/smoke dampers shall also meet the testing requirements contained in NFPA 80, Section 19.3.

7.5 Acceptance Testing.

7.5.1 Acceptance testing of smoke dampers shall be performed by a qualified person with knowledge and understanding of the operating components of the type of assembly to be tested.

7.5.2 Before testing, a visual inspection shall be performed to identify any damaged or missing parts that could create a hazard during testing, or affect operation or resetting.

7.5.3* Acceptance testing shall be conducted after the building mechanical ventilation system has been balanced, and in operation under maximum airflow, if equipped with a variable air volume system.

N 7.5.4 Acceptance testing shall be conducted by removing electrical power or air pressure from the actuator and ensuring that the damper fully closes.

7.5.5 Electrical power or air pressure shall then be reapplied to the damper to confirm that it returns to its full-open position.

7.5.6 A record of these inspections and testing shall be made in accordance with 7.6.4.

7.6 Periodic Testing.

7.6.1 General.

7.6.1.1 Smoke dampers for dedicated and nondedicated smoke control systems shall be inspected and tested in accordance with NFPA 92.

7.6.1.2 Combination fire/smoke dampers shall be inspected and tested in accordance with NFPA 80.

7.6.2* Testing Frequency.

7.6.2.1 Each damper shall be inspected and tested 1 year after the completion of acceptance testing.

7.6.2.2* After the inspection and test required by 7.6.2.1, the test and inspection frequency shall then be every 4 years, except in buildings containing a hospital, where the frequency shall be every 6 years.

N 7.6.2.3* In existing, fully ducted HVAC systems, periodic testing shall not be required for a single damper that is not accessible within a rated barrier or shaft.

7.6.3 Test Method.

7.6.3.1 General.

N 7.6.3.1.1 All tests shall be completed in a safe manner by personnel wearing personal protective equipment (PPE).

7.6.3.1.2 Fans shall not be permitted to be shut down during the test.

7.6.3.2 Visual Inspection Method. Visual inspection shall include all of the following:

- (1) Visually confirm that the damper is in the full-open or full-closed position as required by the system design.
- (2) Command and visually confirm the damper to the full-closed or full-open position.
- (3) Restore and visually confirm the damper to the original operating position as required by the system design.

N 7.6.3.3 Remote Inspection Method.

N 7.6.3.3.1 General.

N 7.6.3.3.1.1 A damper with remote inspection capability shall positively indicate when the damper is fully open and fully closed.

N 7.6.3.3.1.2 The initial remote inspection shall include a visual inspection of the damper in accordance with 7.6.3.2.

N 7.6.3.3.1.3 The visual inspection shall confirm that the position indication method accurately reflects the full-open and full-closed position of the damper.

N 7.6.3.3.2 Test Procedure.

N 7.6.3.3.2.1 The full-open or full-closed position, as required by the system design, shall be confirmed via the damper's position indication device.

N 7.6.3.3.2.2 The damper shall be commanded and confirmed to the full-closed or full-open position.

N 7.6.3.3.2.3 The damper shall be confirmed to be in the original operating position as required by the system design.

N 7.6.3.3.2.4 If the remote inspection fails to comply with the requirements of 7.6.3.3.2.1 through 7.6.3.3.2.3, a visual inspection shall be performed in accordance with 7.6.3.2.

7.6.4 Documentation.

7.6.4.1 All inspections and testing shall be documented indicating the location of the damper, date of inspection, name of inspector, and deficiencies discovered.

7.6.4.2 The documentation shall have space to indicate when and how the deficiencies were corrected.

7.6.4.3 All documentation shall be maintained for at least three test cycles and made available for review by the AHJ.

7.7 Maintenance.

7.7.1 Any reports of abrupt changes in airflow or noise from the duct system shall be investigated to verify that it is not related to damper operation.

▲ 7.7.2* All exposed moving parts of the damper shall be lubricated as required by the manufacturer.

7.7.3 If the damper is not operable, repairs shall begin as soon as possible.

7.7.4 Following any repairs, the damper shall be tested for proper operation in accordance with Section 7.6.

7.7.5 Smoke damper actuation shall be initiated at a time interval recommended by the actuator manufacturer.

7.7.6 All maintenance shall be documented and records shall be retained in accordance with 7.6.4.

N 7.8 Field Modifications.

N 7.8.1 Any field modification made to the damper shall be per the damper manufacturer's installation instructions and listing.

N 7.8.2 Where the field modification includes adding the capability for remote inspection, the position indicator devices and monitoring equipment shall be tested for functionality.

Chapter 8 Smoke-Protective Curtain Assemblies

8.1 General.

8.1.1* This chapter shall cover the installation, inspection, testing, and maintenance of smoke-protective curtain assemblies installed to protect vertical openings.

8.1.2 Smoke-protective curtain assemblies that are protecting vertical openings shall be air leakage tested in accordance with ANSI/UL 1784, *Air Leakage Tests of Door Assemblies*.

▲ 8.1.3 Smoke-protective curtain assemblies shall be identified by an "S" label attached to the bottom bar of the curtain indicating a maximum air leakage rate of 3 ft³ /min/ft² (0.9 m³/min /m²) and the tested pressure differential of 0.1 in., 0.2 in., or 0.3 in. of water (25 Pa, 50 Pa, 75 Pa).

8.2 Mounting of Smoke-Protective Curtain Assemblies.

8.2.1 Smoke-protective curtain assemblies shall be mounted to supporting construction in accordance with their listing and with the manufacturer's installation instructions.

8.2.2 Items that are not a part of a smoke-protective curtain assembly shall not be field attached to any component of a smoke-protective curtain assembly.

8.2.3 Access to, and clearances between, surrounding construction and a smoke-protective curtain assembly shall allow for required testing and maintenance.

8.3 Assembly Components.

8.3.1 Smoke-protective curtain assemblies shall be either self-closing or automatic-closing.

8.3.1.1 Smoke-protective curtain assemblies shall not have a delay in the initiation of closing of more than 10 seconds.

8.3.1.2 Smoke-protective curtain assemblies shall have an average closing speed of not less than 6 in./sec (152 mm/sec) or more than 24 in./sec (610 mm/sec).

8.3.2* Curtains shall be permitted to be sewn by qualified persons in accordance with the manufacturer's instructions.

8.4 Power Operators. Power operators shall be provided with a standby or an emergency power source to close the curtain upon activation or shall be capable of closing the curtain without power.

8.5 Installation. Smoke-protective curtain assemblies shall be installed in accordance with their listing and with the manufacturer's installation instructions.

8.6 Inspection, Testing, and Maintenance.

8.6.1 Following completion of installation, smoke-protective curtains shall be inspected and tested in accordance with Section 8.7.

8.6.2 A record of all inspections and testing shall be signed by the inspector and kept for inspection by the AHJ.

8.6.2.1 Records of acceptance testing following completion of installation shall be retained for the life of the assembly.

8.6.2.2 Records of periodic inspections and testing shall be retained for a period of at least 3 years.

8.6.2.3 The records shall be on a medium that will survive the retention period. Paper or electronic media shall be permitted. [72:14.6.2.3]

8.6.2.4 A record of all inspections and testing shall be provided that includes, but is not limited to, the following information:

- (1) Date of inspection
- (2) Name of facility
- (3) Address of facility
- (4) Name of person(s) performing inspections and testing
- (5) Company name and address of inspecting company
- (6) Signature of inspector of record
- (7) Individual record of each inspected and tested smoke-protective curtain assembly
- (8) Opening identifier and location of each inspected and tested smoke-protective curtain
- (9) Type and description of each inspected and tested smoke-protective curtain
- (10) Verification of visual inspection and functional operation
- (11) Listing of any deficiencies

8.6.2.5 Upon completion of maintenance work, smoke-protective curtain assemblies shall be inspected and tested in accordance with Section 8.7.

8.7 Acceptance Testing.

8.7.1 Acceptance testing of smoke-protective curtain assemblies shall be performed by a qualified person with knowledge and understanding of the operating components of the type of assembly being subject to testing.

8.7.2 Before testing, a visual inspection shall be performed to identify any damaged or missing parts that can create a hazard during testing or affect operation or resetting.

8.7.3 Acceptance testing shall include the closing of the smoke-protective curtain assembly by all means of activation.

8.7.4 A record of these inspections and testing shall be made in accordance with Section 8.6.

8.7.5 The following items shall be verified:

- (1) Labels are clearly visible and legible.
- (2) No open holes or breaks exist in surfaces of the curtain or in the stitching of the curtain.
- (3) Curtain, guides, and coil are aligned, level, plumb, and true.
- (4) Mounting and assembly bolts are intact and secured.
- (5) Attachments to jambs are with bolts, expansion anchors, or as otherwise required by the listing.
- (6) Smoke detectors, if equipped, are installed, operational, and in accordance with *NFPA 72*.
- (7) No parts are missing or broken.
- (8) Auxiliary hardware items that interfere or prohibit operation are not installed on the curtain or frame.
- (9) No field modifications to the smoke-protective curtain assembly have been performed that void the label.
- (10) Smoke-protective curtain assemblies have an average closing speed of not less than 6 in./sec (152 mm/sec) or more than 24 in./sec (610 mm/sec).

8.7.6 Smoke-protective curtain assemblies shall be drop-tested twice.

8.7.7 Fusible links, release devices, and other movable parts shall not be painted or coated with other materials that could interfere with the operation of the assembly.

8.8 Closing Devices.

8.8.1 Smoke-protective curtain assemblies shall be inspected and tested to check for proper operation and full closure.

8.8.2 Resetting of the automatic-closing device shall be performed in accordance with the manufacturer's instructions.

8.9 Periodic Inspection and Testing.

8.9.1 Periodic inspections and testing of smoke-protective curtain assemblies shall be performed not less than annually.

8.9.2 As a minimum, the provisions of Section 8.7 shall be included in the periodic inspection and testing procedure.

8.10 Maintenance.

8.10.1 Repairs shall be made, and defects that could interfere with operation shall be corrected without delay.

8.10.2 Any breaks in the face covering of curtains shall be repaired in accordance with manufacturer's requirements without delay.

8.10.3 Where a smoke-protective curtain assembly or any part of its appurtenances is damaged to the extent that it could impair the assembly's proper emergency function, the following actions shall be performed:

- (1) The smoke-protective curtain assembly or any part of its appurtenances shall be repaired with labeled parts or parts obtained from the original manufacturer.
- (2) The smoke-protective curtain assembly shall be tested to ensure emergency operation and closing upon completion of the repairs.

8.10.4 If repairs cannot be made with labeled components or parts obtained from the original manufacturer, the smoke-protective curtain assembly or appurtenances shall be replaced.

N Chapter 9 Smoke-Protective Curtain Assemblies for Hoistways

N 9.1 General.

N 9.1.1 This chapter shall cover the installation, inspection, testing, and maintenance of smoke-protective curtain assemblies installed at hoistways to protect vertical openings.

N 9.1.2 Smoke-protective curtain assemblies for hoistways that are protecting vertical openings shall be air leakage-tested in accordance with ANSI/UL 1784, *Air Leakage Tests of Door Assemblies*.

N 9.1.3 Smoke-protective curtain assemblies for hoistways shall be identified by an "S" label attached to the bottom bar of the curtain, indicating a maximum air leakage rate of 3 ft³/min/ft² (0.9 m³/min/m²) and a tested pressure differential of 0.1 in., 0.2 in., or 0.3 in. of water (25 Pa, 50 Pa, 75 Pa).

N 9.2 Mounting of Smoke-Protective Curtain Assemblies for Hoistways.

N 9.2.1 Smoke-protective curtain assemblies for hoistways shall be mounted to supporting construction in accordance with their listing and with the manufacturer's installation instructions.

N 9.2.2 Items that are not a part of a smoke-protective curtain assembly for hoistways shall not be field-attached to any component of a smoke-protective curtain assembly for hoistways.

N 9.2.3 Access to, and clearances between, surrounding construction and a smoke-protective curtain assembly for hoistways shall allow for normal operation, required testing, and maintenance.

N 9.3 Assembly Components.

N 9.3.1 Smoke-protective curtain assemblies for hoistways shall be self-closing or automatic-closing.

N 9.3.1.1 Smoke-protective curtain assemblies for hoistways shall not have a delay in the initiation of closing of more than 10 seconds.

N 9.3.1.2 Smoke-protective curtain assemblies for hoistways shall have an average closing speed of not less than 6 in./sec (152 mm/sec) or more than 24 in./sec (610 mm/sec).

N 9.3.1.3 Smoke-protective curtain assemblies installed at hoistway openings shall be connected to the local lobby smoke detector or as required as part of an engineered smoke evacuation system.

N 9.4 Power Operators. Power operators shall be provided with a standby or an emergency power source to close the curtain upon activation, or be capable of closing the curtain without power.

N 9.5 Installation.

N 9.5.1 Smoke-protective curtain assemblies for hoistways shall be installed in accordance with their listing and with the manufacturer's installation instructions.

N 9.5.2 Smoke-protective curtain assemblies for hoistways shall be installed in accordance with ASME A17.1, *Safety Code for Elevators and Escalators*, and other applicable elevator safety codes.

N 9.6 Inspection, Testing, and Maintenance.

N 9.6.1 Following completion of installation, smoke-protective curtain assemblies for hoistways shall be inspected and tested in accordance with 9.6.3.

N 9.6.2 A record of all inspections and testing shall be signed by the inspector and kept for inspection by the AHJ.

N 9.6.2.1 Records of acceptance testing following completion of installation shall be retained for the life of the assembly.

N 9.6.2.2 Records of periodic inspections and testing shall be retained for a period of at least 3 years.

N 9.6.2.3 The records shall be on a medium that will survive the retention period. Paper or electronic media shall be permitted.

N 9.6.2.4 A record of all inspections and testing shall be provided that includes, but is not limited to, the following information:

- (1) Date of inspection
- (2) Name of facility
- (3) Address of facility
- (4) Name of person(s) performing inspections and testing
- (5) Company name and address of inspecting company
- (6) Signature of inspector of record
- (7) Individual record of each inspected and tested smoke-protective curtain assembly
- (8) Opening identifier and location of each inspected and tested smoke-protective curtain assembly
- (9) Type and description of each inspected and tested smoke-protective curtain assembly
- (10) Verification of visual inspection and functional operation
- (11) Listing of any deficiencies

N 9.6.3 Acceptance Testing.

N 9.6.3.1 Acceptance testing of smoke-protective curtain assemblies for hoistways shall be performed by a qualified person with knowledge and understanding of the operating components of the type of assembly being subject to testing.

N 9.6.3.2 Before testing, a visual inspection shall be performed to identify any damaged, field-modified, or missing parts that can create a hazard during testing, or affect operation or resetting.

N 9.6.3.3 Acceptance testing shall include the closing of the smoke-protective curtain assembly for hoistways by all means of activation.

N 9.6.3.4 The following items shall be verified:

- (1) Labels are clearly visible and legible.
- (2) No open holes exist in surfaces of the curtain or side retention system.
- (3) The curtain covers the opening as intended and is aligned, level, plumb, and true.

- (4) Mounting and assembly bolts are intact and secured.
- (5) Attachments to building structure are with bolts, anchors, or as otherwise required by the listing and the manufacturer's instructions.
- (6) Hoistway lobby smoke detectors, if equipped, are installed, operational, and in accordance with *NFPA 72*.
- (7) No parts are missing or broken.
- (8) Auxiliary hardware items that interfere or prohibit operation are not installed on the curtain or assembly.
- (9) No field modifications to the smoke-protective curtain assembly have been performed that void the label.
- (10) Smoke-protective curtain assemblies for hoistways have an average closing speed of not less than 6 in./sec (152 mm/sec) or more than 24 in./sec (610 mm/sec).

N 9.6.4 Periodic Inspection and Testing.

N 9.6.4.1 Periodic inspections and testing of smoke-protective curtain assemblies for hoistways shall be performed not less than annually.

N 9.6.4.2 As a minimum, the provisions of 9.6.3.4 shall be included in the periodic inspection and testing procedure.

N 9.6.4.3 A record of these inspections and testing shall be made in accordance with 9.6.2.

N 9.6.4.4 Smoke-protective curtain assemblies for hoistways shall be drop-tested twice.

N 9.6.4.5 Operational elements of the assembly shall not be painted or coated with other materials that could interfere with the operation of the assembly.

N 9.6.5 Maintenance.

N 9.6.5.1 Repairs shall be made, and defects that could interfere with operation shall be corrected without delay.

N 9.6.5.2 Repairs to curtains shall be made by qualified persons in accordance with their listing and the manufacturer's repair instructions.

N 9.6.5.3 Where a smoke-protective curtain assembly for hoistways or any part of its appurtenances is damaged to the extent that it could impair the assembly's proper emergency function, the following actions shall be performed:

- (1) The smoke-protective curtain assembly for hoistways or any part of its appurtenances shall be repaired with labeled parts or parts obtained from the original manufacturer.
- (2) The smoke-protective curtain assembly for hoistways shall be tested in accordance with 9.6.4 to ensure emergency operation and closing upon completion of the repairs.

N 9.6.5.4 If repairs cannot be made with labeled components or parts obtained from the original manufacturer, the smoke-protective curtain assembly or appurtenances shall be replaced.

N 9.6.5.5 Upon completion of maintenance work, smoke-protective curtain assemblies for hoistways shall be inspected and tested in accordance with 9.6.4.

Annex A Explanatory Material

Annex A is not a part of the requirements of this NFPA document but is included for informational purposes only. This annex contains explanatory material, numbered to correspond with the applicable text paragraphs.

A.1.2 For the purposes of this standard, smoke can be considered to be airborne particulates and gases resulting from combustion. Therefore, to understand smoke movement it is only necessary to understand air movement. Hot smoke, however, will be buoyant and will be located above the neutral plane in the fire compartment. As it moves away from the fire source, it will cool, lose its buoyancy, and become less stratified. Beyond the immediate influence of the fire, smoke will behave just as warm or cool air would behave. It will be driven by pressure differentials within the building, or it will follow air currents created by the heating, ventilating, and air-conditioning (HVAC) system or smoke management system in the building. Pressure differentials can be the result of the following:

- (1) Fire pressure buildup, which would drive only the smoke out of the compartment or area of origin
- (2) Stack effect due to temperature differentials between the interior and exterior of the building
- (3) Wind
- (4) Pressures created mechanically using HVAC systems, exhaust fans, supply or pressurization fans, vents, and smoke management systems

This standard has its beginnings in measurements from test results reported in *Operation School Burning* and from NFPA Technical Paper No. 341, "Factors in Controlling Smoke in High Buildings," where tenable or tolerable smoke concentration lists were established. Since the publication of *Operation School Burning* in 1959, considerable effort in the field of fire protection has been focused upon smoke movement in the built environment. NFPA 101 and NFPA 90A recognize that smoke control can be either active or passive. The passive approach recognizes the long-standing compartmentation concept, which requires that fans shut down and fire/smoke dampers in ductwork close under fire conditions. The active approach utilizes the building's HVAC systems to create differential pressures to prevent smoke migration from the fire area and to exhaust the products of combustion to the outside. Active smoke control systems use passive barrier components that include smoke door assemblies to create zones or areas for effective smoke movement as an essential component.

Smoke management utilizing active and passive methods in combination to modify smoke movement must be engineered into a system and focused on protection of property or people. While passive methods of smoke management do exist (see NFPA 204), dynamic smoke control systems using mechanical equipment to meet design goals dominate. NFPA 92 is used for the design, installation, testing, operation, and maintenance of systems for smoke control and provides methodologies for determining smoke development in large spaces.

Smoke door assemblies are intended to maintain egress, allow for the rescue of the occupants, or allow occupants to remain in an area of refuge. The required duration of smoke protection can be equated with the path of egress. Evacuation typically starts in a room, progresses through a corridor, perhaps passes through a smoke barrier or horizontal exit, and proceeds through an entrance to the exit, which can be a stair

enclosure, exit passageway, or the exit discharge. As with fire door assemblies, the longest time of protection is generally required at the entrance to an exit enclosure or horizontal exit, with shorter durations appropriate for preceding doors.

This path-of-egress arrangement is compatible with the protect-in-place concept as occupants are expected to be moved from one compartment to another for protection or, in some cases, protected in rooms other than the room of fire origin.

Occupancies not typical of this scenario include atria, malls, and open office plans. Areas of this sort can be adequately protected by reasonably tight-fitting doors without specific smoke door ratings because of the large volume of space involved.

A.1.3 While the use of smoke door assemblies will be helpful in reducing the flow of airborne gases, it is not assumed that using this standard obviates the concern over toxic combustion products.

NFPA 101 and building codes include specific requirements for smoke door assemblies and should be consulted in every instance. NFPA should be followed where fire door assemblies are used as smoke door assemblies.

The leakage characteristics of adjacent wall, ceiling, and floor assemblies should be considered. It is generally viewed to be of marginal benefit to install smoke door assemblies in locations where adjacent walls, ceilings, or floors do not effectively resist the passage of smoke. (For additional information, see ASHRAE/ICC/SFPE/NFPA *Handbook of Smoke Control Engineering*.)

For protection against smoke migration into spaces of large volume, a reasonably tight-fitting door can be considered adequate because of the relatively long time it would take for such a space to become untenable due to smoke. Conversely, the average 8 ft (2.4 m) high by 4 ft to 6 ft (1.2 m to 1.8 m) wide corridor can become untenable in less than 2 minutes, as shown in a test conducted in California and documented in *Operation School Burning*, where the fire room door was open.

Tests indicate that listed gaskets, if properly installed and maintained in accordance with manufacturer's instructions, do a good job of reducing smoke infiltration to a sufficient level to provide protection against smoke infiltration through the door assembly. In a fire condition, there would normally be a room of fire origin, and temperatures would be high in this area. Immediately outside the room of origin there might be warm smoke.

A.1.3.1 Smoke door assemblies used in locations likely to be in proximity to a fire can be exposed to elevated temperatures, including door assemblies separating rooms and corridors. Such door assemblies, whether rated as fire doors or not, should restrict the passage of smoke that can be heated to a temperature of 400°F (204°C). In a fully sprinklered building, protection against elevated-temperature smoke might not be necessary, and the criteria for protection against ambient-temperature smoke might be appropriate.

Mention should be made of the effects of automatic sprinkler protection on smoke. The activation of an automatic sprinkler occurs early in a flaming fire condition, usually within approximately 5 minutes after visible flaming is observed. Temperatures immediately drop to almost ambient, and smoke

is driven to the floor and diffused throughout the available space. Smoke production rate is reduced as the fire size decreases and the temperature of the flame plume is reduced. The temperature of the smoke is also reduced to near ambient. Thus, in a sprinklered building it can be appropriate to treat smoke as if it were at or near ambient temperature. Fewer mitigating measures might be needed to control smoke movement since the production rate of smoke will be reduced. However, under a smoldering fire condition, sprinkler activation can be delayed and this, too, should be considered.

Fire door assemblies protecting stair enclosures and vestibules adjacent to stair enclosures, for example, are more likely to be exposed to ambient temperature smoke, provided there are no combustible materials in the enclosure. These doors can form part of a control system involving pressurized stairwells or vestibules. The air leakage characteristics of such door assemblies are an essential part of smoke control design.

A.1.3.2 See NFPA 92 for additional information on protection of elevator openings.

A.3.2.1 Approved. The National Fire Protection Association does not approve, inspect, or certify any installations, procedures, equipment, or materials; nor does it approve or evaluate testing laboratories. In determining the acceptability of installations, procedures, equipment, or materials, the authority having jurisdiction may base acceptance on compliance with NFPA or other appropriate standards. In the absence of such standards, said authority may require evidence of proper installation, procedure, or use. The authority having jurisdiction may also refer to the listings or labeling practices of an organization that is concerned with product evaluations and is thus in a position to determine compliance with appropriate standards for the current production of listed items.

A.3.2.2 Authority Having Jurisdiction (AHJ). The phrase "authority having jurisdiction," or its acronym AHJ, is used in NFPA documents in a broad manner, since jurisdictions and approval agencies vary, as do their responsibilities. Where public safety is primary, the authority having jurisdiction may be a federal, state, local, or other regional department or individual such as a fire chief; fire marshal; chief of a fire prevention bureau, labor department, or health department; building official; electrical inspector; or others having statutory authority. For insurance purposes, an insurance inspection department, rating bureau, or other insurance company representative may be the authority having jurisdiction. In many circumstances, the property owner or his or her designated agent assumes the role of the authority having jurisdiction; at government installations, the commanding officer or departmental official may be the authority having jurisdiction.

A.3.2.4 Listed. The means for identifying listed equipment may vary for each organization concerned with product evaluation; some organizations do not recognize equipment as listed unless it is also labeled. The authority having jurisdiction should utilize the system employed by the listing organization to identify a listed product.

A.3.3.7.2 Elevated Temperature. Depending on the function of the door, its location in relation to the fire, and the movement of hot gases and air, door assemblies might be exposed to elevated smoke temperatures. Warm smoke has an assumed temperature at the exposed face of the door at or near 400°F (204°C); hot smoke has an assumed temperature at the exposed face of the door in excess of 400°F (204°C). A nation-

ally recognized standard test for measuring hot smoke temperature leakage does not exist.

It has been determined from many full-scale fire tests of compartments that the maximum instantaneous pressure differential created by an uncontrolled fire can approach 0.15 in. of water (37.5 Pa). More typically, a pressure differential of 0.06 in. of water to 0.10 in. of water (15 Pa to 25 Pa) is achieved over the period of most intense burning in light fire loading occupancies such as residential, health care, and business (offices).

In sprinklered buildings where the fire will be controlled, it is anticipated that the maximum pressure differential generated should not exceed 0.05 in. of water (12.5 Pa).

Typical stair pressurization systems can often result in pressure differentials as high as 0.25 in. of water to 0.50 in. of water (62.5 Pa to 125 Pa) across the door assembly.

Stack effect can also play a major role in determining pressure that must be overcome in order to pressurize shafts, such as elevators and stairs, to prevent smoke infiltration. Pressure differentials between the exterior and unvented shafts can range from virtually nothing to as much as 0.5 in. of water to 1.0 in. of water (125 Pa to 250 Pa) or more, depending on the location of the building neutral pressure plane, the height of the building, and the outside temperature. The ASHRAE/SFPE handbook, *Principles of Smoke Management*, addresses smoke management applications including pressurized stairwells, pressurized elevators, and pressure differentials that designers are likely to encounter.

The quantity of air movement through a door gap can be determined by the following general formula:

[A.3.3.7.2]

$$Q = KAP^{\frac{1}{N}}$$

where:

Q = volume flow rate of air

K = orifice coefficient for the gap around the door perimeter

A = area of the gap

P = pressure differential across the door

N = number between 1 and 2 that can be determined empirically

(For more information, see NFPA's *Fire Protection Handbook*.)

A.3.3.8 Tenable Environment. It is not expected that a tenable environment will be completely free of smoke. [92, 2018]

A.4.2.3 Hardware requiring extensive door mortising that could provide considerable air leakage through the door panel should be tested if required by the testing laboratory.

A.4.3.1 Smoke management systems both affect and are affected by smoke door assemblies. Pressurized stair enclosures, for example, are more easily engineered when leakage through the stair doors is reduced. In other areas, pressurization can inhibit smoke flow so that reasonably tight-fitting doors unrated for smoke protection can be entirely appropriate.

Complete sealing of doors is not always desirable. A disadvantage of complete sealing is the difficulty of opening or closing doors because of the pressure differential. Some smoke

management designs call for some areas to be pressurized. A small pressure acting across the full area of a door can exert sufficient force to make opening a door difficult. A seal must be first broken to equalize the pressure on both sides of the door before the door can be opened easily.

Smoke doors should take the entire smoke management system into account. The amount of leakage tolerated will vary according to the degree of compartmentation, whether smoke management systems are used, and whether the building is protected by sprinklers.

An engineering evaluation should be performed when the volume of the space to be protected is known so that the values can be modified to restrict smoke leakage in terms of a specified smoke tenability level. In assessing tenability, the evaluation should include, but not be limited to, fuel load, pressurization, stack effect, presence of smoke control systems, and construction, as well as smoke leakage.

A.4.3.2 The artificial door bottom is used during the air-leakage tests of ANSI/UL 1784, *Air Leakage Tests of Door Assemblies*, to better ascertain the amount of air leakage along the vertical edges and across the top edge(s) of the doors. An example of an artificial door bottom is duct tape used to seal the gap between the bottom of the door and the sill during the air-leakage test. The application of gasketing at the door bottom on installed smoke door assemblies is sometimes required in areas that are pressurized for smoke control. In the majority of cases, it is not necessary to seal the gap under the door.

A.4.3.3 Test data exists for certain door types demonstrating that air leakage at ambient temperature is greater than warm air temperature leakage. In such instances, the air leakage rate for ambient temperature could also apply for warm temperatures when additional data tests are not conducted at elevated temperature.

A.4.3.4 Pressure differentials of at least 0.04 in. of water (10 Pa) are developed in the upper parts of rooms that are involved in fire. Considerably higher pressure differentials can exist in rooms, corridors, and stair enclosures due to the action of air-handling systems, stack effect, and wind.

In sprinklered buildings where the fire will be controlled, it is anticipated that the maximum pressure differential generated should not exceed 0.05 in. of water (12.5 Pa). See pressure differences discussed in NFPA 92 and ASHRAE/ICC/SFPE/NFPA *Handbook of Smoke Control Engineering*.

A.4.4 Non-fire-rated smoke doors might not be marked with an "S" label or any other markings that indicate the maximum air leakage rate. Gasketing manufacturers might be able to provide anecdotal information based on the testing of their products. Due to the size, shape, material, and configuration of gasketing products, the label frequently is marked on the packaging of the gasketing material rather than on the product. Verifying the maximum air leakage rate of a smoke door without a fire protection rating might require additional research if the door does not carry an "S" label.

A.5.1.3.1 Smoke door assemblies, both fire-rated and non-fire-rated, should be operable under normal conditions. Operability includes closing easily and completely and, where required, positively latching in the closed position. Operability, in the case of smoke door assemblies, also includes the sealing of the door against the passage of smoke. Fire-rated doors are not

required to be operable after exposure to a fire. Similarly, non-fire-rated doors should not be expected to be operable after exposure to a fire.

A.5.1.5.2 Generally, the replacement of hardware components on swinging doors (hinges, pivots, door closers, etc.) is not considered to be a field modification, provided the replacement hardware does not require additional cutting, mortising, or boring into the doors and frames and the hardware meets the criteria specified elsewhere in the standard. Likewise, the installation of surface-mounted items like protection plates is not considered to be a field modification. Cutting doors for vision panels, enlarging existing cutouts for vision panels, and trimming doors in height or width are examples of field modifications, as is installing hardware components that require additional cutting and mortising of the doors or frames.

A.5.2.2 Newer technology includes the use of bar codes and other electronic devices. This section recognizes that completed and filed bar code reports should be considered signed by the inspector.

A.5.2.2.2 In many cases, AHJs are not able to inspect every building in their jurisdiction each year. Inspection and testing records need to be retained during the intervening periods between the AHJ's formal visits to provide evidence that the inspections and testing were performed as required by this standard. Additionally, maintenance records documenting that the necessary corrective actions have been made in accordance with this standard should be stored with the inspection and testing records for the same period of time. Retaining the records for 7 years allows the AHJ to look back over an extended period of time to verify that the smoke door assemblies are being properly maintained.

A.5.2.2.3 Installation of new smoke door assemblies should be documented in the same manner and level of detail as the periodic inspections and testing of smoke door assemblies required by 5.2.4 and 5.2.5. Records of new smoke door assemblies should be retained with the periodic inspections and testing records for the facility.

A.5.2.2.4(8) Each smoke door assembly in a facility should be assigned a unique identifier code (e.g., door number) that can be used to track the assembly's compliance and maintenance records throughout the lifetime of its installation. Identifier codes could be a door assembly number, bar code, or other code that is unique to each smoke door assembly in the facility.

A.5.2.2.4(9) To aid the AHJ during the review of the inspections and testing reports, the records should include a description of the smoke door assembly. The following door types are listed in NFPA 80 and could have application under this section:

- (1) Swinging doors with builders hardware
- (2) Swinging doors with fire door hardware
- (3) Horizontally sliding doors
- (4) Special purpose horizontally sliding accordion or folding doors
- (5) Vertically sliding fire doors
- (6) Rolling steel doors
- (7) Fire shutters
- (8) Service counter fire doors
- (9) Hoistway doors for elevators and dumbwaiters
- (10) Chute doors
- (11) Access doors
- (12) Fabric fire safety curtain

A.5.2.2.4(10) Functional operation of smoke door assemblies should include testing of the closing device, complete closure of the door from the full-open position, and full engagement of latch(es) where required by door type. Functional testing of automatic-closing or power-operated smoke door assemblies and electrically controlled latching hardware might need to be coordinated with the facility during other electrically controlled system tests. Where required by other standards, the force to open a door should be recorded using a door pressure gauge.

A.5.2.4 Visual inspection and functional testing of smoke door assemblies require the persons performing the inspections and testing to be thoroughly knowledgeable of the various components and systems that are used to create the assemblies. Inspectors of swinging doors should be able to recognize which components can or cannot be used on specific assemblies, which requires training and experience on the part of the persons performing the inspections. Additionally, AHJs should be able to rely on the competency, expertise, experience, and knowledge of the smoke door inspectors in their jurisdiction.

A.5.2.4.1 Any smoke door assembly or component that has a history of recurring failures should be evaluated for possible replacement or other corrective measures.

A.5.2.4.5.2(13) Fusible links should not be coated with any materials such as fireproofing, drywall compound, or spray texturing.

A.5.3 See Annex B for information regarding performance-based inspection, testing, and maintenance options for smoke door assemblies.

A.5.4.1 The determination of the time required for corrective action should be based on a risk analysis and the availability of replacement materials.

A.6.1 Swinging smoke door assemblies fall into two categories, fire rated and non-fire rated. Fire-rated smoke door assemblies are also required to comply with NFPA 80. Where there are conflicting requirements for fire-rated doors, NFPA 80's requirements take precedence over all other requirements. Additionally, building, fire, and life safety codes contain specific requirements that affect the design and installation of swinging smoke door assemblies. Some of the requirements of Chapter 6 have been adapted from the requirements found in Chapter 8 of NFPA 101.

Generally, swinging smoke door assemblies without fire protection rating are composed of many of the same components that are used on swinging fire door assemblies. In many cases, the internal construction of the door leaves is the main difference between the two categories of smoke door assemblies. Each type of swinging smoke door assembly utilizes the same types of frames, doors, and builders hardware (hinges, latching hardware, closing devices, etc.) and are virtually identical except for the labels that indicate the door is fire rated. For that reason, many of the requirements of Chapter 6 refer directly to NFPA 80 or otherwise adapt applicable NFPA 80 requirements for use on non-fire-rated swinging smoke door assemblies.

Many of the components used in non-fire-rated smoke door assemblies are not specifically tested or listed by nationally recognized testing laboratories for use on smoke door assemblies, with the exception of gasketing materials and products

that have been subjected to testing in accordance with ANSI/UL1784, *Air Leakage Tests of Door Assemblies*.

Users of this standard are encouraged to review related codes and standards to determine the applicable requirements for a specific smoke door assembly. When competing requirements are found in the related codes and standards, the AHJ should be consulted to determine which requirements take precedence.

A.6.3 Non-fire-rated doors used as smoke doors in door openings that are not required to be protected by fire doors might be constructed of aluminum, fiberglass, hollow metal, steel, wood, or other suitable materials. Generally, non-fire-rated smoke door assemblies are required to be self-closing or automatic closing and swing easily and freely, which requires ball bearing or anti-friction bearing hinges or pivots. Smoke door assemblies are required to have positive latching hardware, unless otherwise specifically exempted by the applicable building, fire, or life safety code.

A.6.3.1 Door leaves used in smoke door assemblies without fire protection rating should be constructed of a design that resists the passage of smoke. Such doors might be 3/4 in. (44 mm) thick solid-bonded wood core doors, which include, but are not limited to, particleboard, agrifiber, structural composite lumber (SCL), and stave core doors. ANSI/WDMA I.S. 1A, *Industry Standard for Interior Architectural Wood Flush Doors*, and ANSI/WDMA I.S. 6A, *Industry Standard for Architectural Stile and Rail Doors*, give specifications governing the construction of solid-bonded wood core doors. Door leaves constructed of aluminum, fiberglass reinforced polyester (FRP), glass, hollow metal, and steel might also be acceptable for use in smoke door assemblies without fire protection ratings; manufacturers' technical data should be consulted to confirm the use of such door leaves in smoke door assemblies.

A.6.3.1.1 Beveling the vertical edges of composite and wood door leaves permits the door leaves to be undersized in width, from the nominal width of the door opening. This is less than doors that have squared vertical edges, thus reducing the clearance dimension between the vertical edges of the doors and the rabbets of the door frames. Industry practice is to bevel the vertical edges of doors 1/8 in.:2 in. (3 mm:51 mm), which results in a bevel of 3 degrees.

A.6.3.2.2 Door stops in the door frames are necessary elements that provide support for the installation of gasketing materials. Door frames with terminated stops are sometimes used in rooms and spaces where the floors are subject to frequent cleaning. Terminated stops convert the lowest portion of the door frames to a flat profile, eliminating corners where dirt and debris might be trapped. In these cases, smoke and draft control gasketing should extend the full height of the shortened frame soffit or door stop. See Figure A.6.3.2.2.

A.6.3.3 Additional information regarding clearances for doors can be found in ANSI/WDMA I.S. 1A, *Industry Standard for Interior Architectural Wood Flush Doors*. Clearances for stile and rail wood doors should be in accordance with ANSI/WDMA I.S. 6A, *Industry Standard for Architectural Stile and Rail Doors*. Clearances for standard hollow metal doors should be in accordance with ANSI/SDI A250.8, *Recommended Specifications for Standard Steel Doors and Frames (SDI-100)*. Clearances for custom hollow metal doors should be in accordance with HMMA 840-07, *Guide Specification for Installation and Storage of Hollow Metal Doors and Frames*.

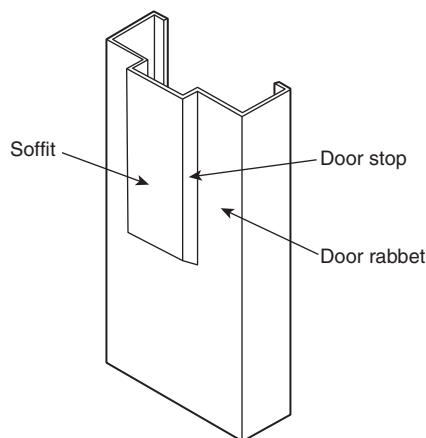

FIGURE A.6.3.2.2 Hollow Metal Door Frame with Terminated Stops.

A.6.3.3.1 In some occupancies, the clearance between the bottom horizontal edge of the door and the floor covering is permitted to be a maximum of 1 in. (25 mm) on doors without fire protection ratings.

A.6.3.4 In most cases, doors are required to be equipped with positive-latching hardware. In some occupancy groups, building, fire, and life safety codes permit positive-latching hardware to be omitted on doors in smoke partitions to rooms such as toilet rooms, bathrooms, shower rooms, sink closets, and similar auxiliary spaces that do not contain flammable or combustible materials.

A.6.3.5.1 Typically, non-fire-rated interior side-hinged and pivoted doors with door closers, including smoke doors without fire protection rating, are required to have a reduced opening force of a maximum of 5 lbf (22 N) once the door leaves are set in motion, to meet accessibility standards such as ANSI A117, *Standard for Accessible and Usable Buildings and Facilities*, or the *Americans with Disabilities Act Accessibility Guidelines (ADAAG)*. In some cases, a door closer with a reduced opening force might not be able to completely close a fully gasketed smoke door reliably, due to the additional pressure applied to the door when the face of the door contacts the perimeter gasketing during closing. Additionally, when positive-latching hardware is required, the door closer needs to overcome the friction of the latching hardware at the end of the closing cycle to completely close the door and cause it to latch.

Fire-rated doors are exempt from the 5 lbf (22 N) reduced opening force due to the recognized need for fire doors to reliably close and latch every time. Similarly, smoke doors without fire protection rating should be exempt from the reduced opening force requirement since their ability to resist the passage of smoke is compromised when the doors fail to close. The AHJ should be consulted for guidance when smoke doors without fire protection rating are not able to close reliably because they are equipped with reduced opening force door closers.

A.6.3.6 Generally, builders hardware products include door hardware components such as conventional hinges, continuous hinges, pivots, floor concealed door closers, flush and automatic door bolts, bored and mortise locks and latches, fire exit hardware and panic hardware, surface-mounted door closers, low energy door operators, protection plates, door stops, and

other hardware items. Smoke gasketing and intumescent gasketing products are considered to be builders hardware components. Builders hardware components are sold separately from the door frames and door leaves and are designed to fit into standardized preparations in the doors and frames in accordance with the ANSI/BHMA A156 series of product standards.

A.6.3.6.4 In general, NFPA 80's requirements for locks and latches are commensurate with industry practices for the installation of positive-latching hardware in smoke doors without fire protection rating and should be applied uniformly, where applicable, to smoke door assemblies.

Latching hardware devices include, but are not limited, to the following:

- (1) Bored, mortise, and interconnected locks and latches
- (2) Panic hardware
- (3) Fire exit hardware
- (4) Automatic flush bolts

A.6.3.6.6.2 In some occupancy groups, door-closing devices are not required to be installed on smoke door assemblies without fire protection ratings. In the absence of a means of holding doors open, occupants might block doors open with chocks, furniture, tie-downs, drop-down/plunger-type devices or other means. Examples of permitted door holder devices include friction catches (e.g., wall mounted, floor mounted, or overhead mounted) and magnetic catches.

Door holder/release devices for swinging doors should, wherever possible, be installed at the top of the door as close as possible to the lock edge and should be located to avoid interference with any other hardware. If necessary, the holder/release device can be located at the bottom of the door as close as possible to the lock edge, with the device installed on the wall or floor.

A.6.3.6.7 Armor, kick, mop, stretcher, and edge guards are types of protection plates. Protection plates should not be permitted to be used to conceal damage that compromises the structural integrity of the doors (i.e., split or delaminating vertical edges) or to conceal cutouts resulting from the removal of hardware items.

A.6.3.6.8 In most cases, the means of fastening for builders hardware products installed on non-fire-rated door assemblies is the same as the means of fastening for builders hardware products installed on fire-rated door assemblies. Installation practices such as drilling pilot holes or tapping holes in steel doors and frames are the same for fire-rated and non-fire-rated doors.

Some fasteners for builders hardware products have specially designed or undercut heads that are necessary to allow the fasteners to seat properly when installed. Use of fasteners from sources other than the respective hardware manufacturers should not be permitted to be used, since their use might affect door operation and might void the warranties of the affected hardware items.

A.6.5.2 The space between the glazing material and its frame or glazing bead should be completely filled with a material that is rated up to 400°F (204°C), forming a continuous seal around the perimeter of the vision panel, that resists the passage of smoke. Similarly, the space between the vision panel frame and

the face of the door should be tightfitting or filled with the same material to resist the passage of smoke.

A.6.7 Gasketing for smoke door assemblies is available in a wide variety of sizes, shapes, materials, colors, and configurations. Some gasketing products are designed to be installed between the rabbet and door stops of the door frames and the doors with adhesive. Other gasketing products include aluminum or stainless steel channels of various profiles that are surface-mounted to the soffit of the door frame by means of mechanical fasteners such as sheet metal screws or self-drilling/self-tapping screws. Gasketing materials in soffit-mounted products include materials such as silicone and neoprene bulbs and sponges and nylon brushes.

A.6.7.1.1 Regardless of the design of gasketing applied to smoke door assemblies, the gasketing is of little value if it is not installed properly. The gasketing material should form an unbroken seal along the full height of the side jambs and across the head jambs and the full height of meeting edges of pairs of doors. Gasketing materials should not be permitted to be cut or notched to fit around other soffit-mounted hardware items such as door closer brackets (e.g., parallel arm brackets) or strikes for panic hardware and fire exit hardware devices. Similarly, astragals applied to the face of doors should not be permitted to be cut out or notched around protruding strike plate lips. Gasketing products should be installed in accordance with the gasketing manufacturer's installation instructions.

When properly installed, gasketing should contact the surface of the door, whether the gasketing is applied to the rabbets and stops or to the soffit area of the frame. A bright concentrated beam of light can be used to verify that the gasketing material blocks the light from passing through to the ungasketed side of the door, which should be indicative of the gasketing's ability to block the passage of smoke and gases.

A.6.7.1.2 Voids created in the door leaves, such as mortising the top rail of doors for overhead stops or concealed overhead door closers, require soffit-mounted gasketing to seal the top edge of the door. See Figure A.6.7.1.2.

A.6.7.1.3 Complete sealing of doors is not always desirable. A disadvantage of complete sealing is the difficulty of opening or closing doors because of the pressure differential. Some smoke management designs call for some areas to be pressurized. A small pressure acting across the full area of the door can exert sufficient force to make opening the door difficult. A seal must be first broken to equalize the pressure on both sides of the door before the door can be opened easily.

A.7.1 Smoke dampers are installed in ducts passing through, or air outlet openings terminating at, smoke barriers, shaft walls, horizontal exit walls, corridor walls, corridor ceilings, and other fire partitions designed to resist the spread of smoke as required by the model building code and other applicable NFPA codes and standards.

N A.7.3.1.2 To verify a damper has been properly installed in accordance with the manufacturer's listing, such as a damper with a retaining angle on one side only, it is necessary to have this information on-site.

A.7.5.3 If the damper is equipped with a fusible link, it is not required to activate the link by heat to test the damper. Visual inspection should be made after the fusible link has been reinstalled to ensure it will not impede closing of the damper.

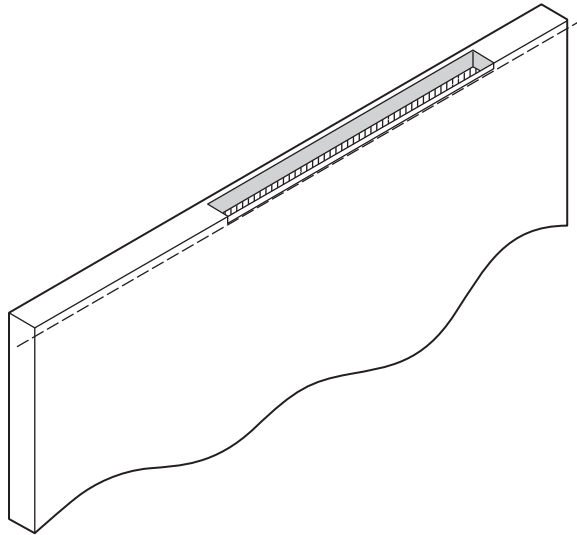

FIGURE A.6.7.1.2 Mortise Cutout in Top of Door Leaf for Overhead Door Stop. The dotted line represents the height of the door stop on the door frame. Gasketing should be installed on the soffit of the door frame so that it contacts the surface of the door below the cutout.

A.7.6.2 If the damper is arranged to be activated automatically, such as by a smoke detector or other device or system, the periodic test required by 7.6.2 need not involve initiation of the detector or other device or system. The damper can be actuated and cycled as part of the associated smoke detector testing in accordance with *NFPA 72*. However, such testing does not meet all the testing and inspection requirements of *NFPA 105*. The *NFPA 72* testing could be combined with the inspection and testing requirements of *NFPA 105*, provided that all testing requirements of *NFPA 105* are met. If operational issues are discovered during *NFPA 72* testing, they should be reported to the building owner for corrective measures as required by *NFPA 105*. For additional information, refer to *NFPA 4*.

A.7.6.2.2 See A.7.6.2.

N A.7.6.2.3 In existing buildings, it is recognized that some dampers might have become inaccessible for various reasons. Inaccessible dampers are those that have physical barriers or limitations where one cannot perform the required inspections or tests. The inability to test a single damper might not pose a significant risk to the performance of the system where the system is fully ducted.

A.7.7.2 Each damper should be examined to ensure that it is not rusted or blocked, with particular attention given to hinges and other moving parts.

A.8.1.1 Smoke-protective curtain assemblies are not to be confused with fabric fire safety curtain assemblies, which are intended for use specifically on proscenium openings.

A.8.3.2 Sections of a smoke-protective curtain may be sewn together when such joints are included in the assembly that was tested in accordance with *UL 1784, Air Leakage Tests of Door Assemblies*.

Annex B Performance-Based Option for the Inspection, Testing, and Maintenance of Smoke Door Assemblies

This annex is not a part of the requirements of this NFPA document but is included for informational purposes only.

B.1 This annex provides the option to adopt a performance-based method as an alternative means of compliance with Section 5.2. Equivalent levels of performance can be demonstrated through quantitative performance-based analyses. This annex provides a basis for implementing a performance-based program acceptable under this option, provided that approval is obtained from the AHJ.

B.2 The concept of a performance-based program is to establish the type and frequency of inspection to demonstrate that the assembly is operational. The goal is to balance the inspection frequency with the proven reliability of the assembly. The goal of a performance-based inspection program is also to adjust test and inspection frequencies commensurate with documented historical equipment performance and desired reliability. Frequencies of tests and inspections under a performance-based program can be extended or reduced from the once-per-year test requirement in 5.2.5 when continued testing of door assemblies in 5.2.4, 5.2.4.4, or 5.2.4.5, as applicable, has been documented indicating a higher or lower degree of reliability compared with the AHJ's and the owner's expectations of performance. Additional program attributes that should be considered in the adjustment of test and inspection frequencies include the following:

- (1) Door maintenance programs
- (2) Door usage frequencies
- (3) History of door repairs
- (4) Building condition
- (5) Consequence of failure

B.3 Fundamental to implementing a performance-based program is that adjusted test and inspection frequencies should be technically defensible to the AHJ and supported by evidence of higher or lower reliability. Data collection and retention should be established so that the data utilized to alter frequencies are representative, statistically valid, and evaluated against firm criteria. Frequencies cannot be arbitrarily extended or reduced without suitable rationale.

B.4 It must be noted that transitioning to a performance-based program requires an expenditure of resources in order to collect and analyze failure data, coordinate review efforts, change program documents, and seek approval from the AHJ. The following factors should be considered in determining whether a transition to a performance-based test program as permitted in Section 5.3 is warranted:

- (1) *Past door reliability.* Have problems routinely been identified during the prescriptive test requirements of Section 5.2, or have doors consistently performed with minimal discrepancies noted?
- (2) *Resource expenditures.* Do the recurring resource expenditures necessary to implement the prescriptive test requirements in Section 5.2 justify the consideration of conducting the detailed analyses needed to support a performance-based testing program?
- (3) *Administrative burden.* Is there an increase to the administrative burden for implementing, documenting, and monitoring a performance-based program?

B.5 A performance-based program requires that a maximum allowable failure rate be established and approved by the AHJ in advance of implementation. The use of historic documented smoke door inspection records can be utilized to determine failure rates. One method of calculating the failure rate of smoke door assemblies is based on the following equation:

$$SDFR(t) = \frac{NF}{NC * t} \quad [B.5]$$

where:

$SDFR(t)$ = smoke door failure rate (failures per year)

NF = number of failures

NC = total number of smoke door assemblies inspected or tested

t = time interval of review (years)

B.6 Example. Data are collected for 50 smoke doors over a 5-year period. The testing is conducted annually as described in 5.2.5. A review of the data identifies five failures: total components, 50; data collection period, 5 years; total failures, 5.

△

$$SDFR = \frac{5}{50 \times 5} = 0.020 \text{ per year} \quad [B.6]$$

B.7 A fundamental requirement of a performance-based program is the continual monitoring of the door component failure rates and determining if they exceed the maximum allowable failure rates as agreed on with the AHJ. The process used to complete this review should be documented and repeatable.

B.8 Coupled with the ongoing review is a requirement for a formalized method of increasing or decreasing the frequency of testing and inspection when the door assemblies exhibit either a higher than expected failure rate or an increase in reliability as a result of a decrease in failures.

B.9 A formal process for reviewing the failure rates and increasing or decreasing the frequency of testing should be well documented. The frequency required for future tests can be reduced to the next inspection frequency and maintained there for a period equaling the initial data review or until the ongoing review indicates that the failure rate is no longer being exceeded.

B.10 Increases and decreases in inspection frequency should be initiated on a step approach such that increments do not exceed 50 percent of the required frequency in 5.2.4, that is, 6 months for any given period under consideration. An example would be going from annual to semi-annual testing when the failure rate exceeds the AHJ's expectations or from annual testing to testing every 18 months when the failure trend indicates an increase in reliability. The maximum time period between inspections regardless of performance should not exceed 36 months. Changes in occupancy, facility management, or ownership that could result in changes in performance should be reassessed by the AHJ to determine if continued acceptability of a performance-based inspection program is warranted.

Annex C Informational References

Δ C.1 Referenced Publications. The documents or portions thereof listed in this annex are referenced within the informational sections of this standard and are not part of the requirements of this document unless also listed in Chapter 2 for other reasons.

C.1.1 NFPA Publications. National Fire Protection Association, 1 Batterymarch Park, Quincy, MA 02169-7471.

NFPA 4, *Standard for Integrated Fire Protection and Life Safety System Testing*, 2018 edition.

NFPA 72®, *National Fire Alarm and Signaling Code*®, 2019 edition.

NFPA 80, *Standard for Fire Doors and Other Opening Protectives*, 2019 edition.

NFPA 90A, *Standard for the Installation of Air-Conditioning and Ventilating Systems*, 2018 edition.

NFPA 92, *Standard for Smoke Control Systems*, 2018 edition.

NFPA 101®, *Life Safety Code*®, 2018 edition.

NFPA 204, *Standard for Smoke and Heat Venting*, 2018 edition.

NFPA *Fire Protection Handbook*, 20th edition.

NFPA Technical Paper No. 341, "Factors in Controlling Smoke in High Buildings."

Operation School Burning, Official Report on a Series of School Fire Tests Conducted April 16, 1959, to June 30, 1959, by the Los Angeles Fire Department, 1959.

C.1.2 Other Publications.

C.1.2.1 ASHRAE Publications. ASHRAE, 1791 Tullie Circle, N.E., Atlanta, GA 30329-2305.

Handbook of Smoke Control Engineering, 2012.

Principles of Smoke Management, 2002.

Δ C.1.2.2 BHMA Publications. Builders Hardware Manufacturers Association, 355 Lexington Avenue, 15th floor, New York, NY 10017.

ANSI/BHMA A156 Series of standards.

N C.1.2.3 ICC Publications. International Code Council, 500 New Jersey Avenue, NW, 6th Floor, Washington, DC 20001-2070.

ICC/ANSI A117.1, *Accessible and Usable Buildings and Facilities*, 2017.

C.1.2.4 UL Publications. Underwriters Laboratories Inc., 333 Pfingsten Road, Northbrook, IL 60062-2096.

ANSI/UL 1784, *Air Leakage Tests of Door Assemblies*, 2015.

C.1.2.5 United States Access Board. 1331 F Street NW, Suite 1000, Washington DC, 20004-1111. www.accessboard.gov

Americans with Disabilities Act Accessibility Guidelines.

C.1.2.6 WDMA Publications. Window and Door Manufacturers Association, 2025 M Street, NW, Suite 800, Washington, DC, 20036-3309.

ANSI/WDMA I.S. 1A, *Industry Standard for Architectural Wood Flush Doors*, 2013.

ANSI/WDMA I.S. 6A, *Industry Standard for Interior Architectural Stile and Rail Doors*, 2013.

C.1.2.7 Other Publications.

HMMA 840-07, *Guide Specification for Installation and Storage of Hollow Metal Doors and Frames*, 2007.

ANSI/SDI A250.8, *Recommended Specifications for Standard Steel Doors and Frames (SDI-100)*, 2014.

• **C.2 Informational References. (Reserved)**

C.3 References for Extracts in Informational Sections.

NFPA 92, *Standard for Smoke Control Systems*, 2018 edition.

Index

Copyright © 2018 National Fire Protection Association. All Rights Reserved.

The copyright in this index is separate and distinct from the copyright in the document that it indexes. The licensing provisions set forth for the document are not applicable to this index. This index may not be reproduced in whole or in part by any means without the express written permission of NFPA.

- A-**
- Administration**, Chap. 1
 - Application, 1.3, A.1.3
 - Equivalency, 1.5
 - Purpose, 1.2, A.1.2
 - Retroactivity, 1.4
 - Scope, 1.1
- Approved**
 - Definition, 3.2.1, A.3.2.1
- Authority Having Jurisdiction (AHJ)**
 - Definition, 3.2.2, A.3.2.2
- D-**
- Definitions**, Chap. 3
- E-**
- Explanatory Material**, Annex A
- G-**
- General Requirements**, Chap. 4
 - Air Leakage Test, 4.3
 - General, 4.1
 - Installation, 4.5
 - Labeling, 4.4, A.4.4
 - Test Specimen, 4.2
- I-**
- Informational References**, Annex C
- Inspection, Testing, and Maintenance of Smoke Door Assemblies**, Chap. 5
 - General, 5.1
 - Application, 5.1.1
 - Field Modifications, 5.1.5
 - Operability, 5.1.3
 - Removal of Smoke Doors, 5.1.2
 - Replacement, 5.1.4
 - Inspections and Testing, 5.2
 - Acceptance Testing, 5.2.4, A.5.2.4
 - Horizontally Sliding, Vertically Sliding, and Rolling Doors, 5.2.4.5
 - Swinging Smoke Door Assemblies, 5.2.4.4
 - Maintenance Records, 5.2.3
 - Periodic Inspection and Testing, 5.2.5
 - Maintenance, 5.4
 - Maintenance of Closing Mechanisms, 5.6
 - Performance-Based Option, 5.3, A.5.3
 - Prevention of Door Blockage, 5.5
- Installation, Testing, and Maintenance of Smoke Dampers**, Chap. 7
 - Acceptance Testing, 7.5
 - Field Modifications, 7.8
 - General, 7.1, A.7.1
 - Installation, 7.3
 - Dampers, 7.3.1
 - Maintenance, 7.7
 - Operational Test, 7.4
 - Smoke and Combination Fire/Smoke Dampers, 7.4.1
 - Periodic Testing, 7.6
 - Documentation, 7.6.4
 - General, 7.6.1
 - Test Method, 7.6.3
 - General, 7.6.3.1
 - Remote Inspection Method, 7.6.3.3
 - General, 7.6.3.3.1
 - Test Procedure, 7.6.3.3.2
 - Visual Inspection Method, 7.6.3.2
 - Testing Frequency, 7.6.2, A.7.6.2
- L-**
- Labeled**
 - Definition, 3.2.3
- Listed**
 - Definition, 3.2.4, A.3.2.4
- P-**
- Performance-Based Option for the Inspection, Testing, and Maintenance of Smoke Door Assemblies**, Annex B
 - Example, B.6
- Q-**
- Qualified Person**
 - Definition, 3.3.1
- R-**
- Referenced Publications**, Chap. 2
- S-**
- Shall**
 - Definition, 3.2.5
- Should**
 - Definition, 3.2.6
- Smoke Damper**
 - Combination Fire/Smoke Damper
 - Definition, 3.3.2.1
 - Definition, 3.3.2
- Smoke Door**
 - Definition, 3.3.3
- Smoke Door Assembly**
 - Definition, 3.3.4
- Smoke-Protective Curtain Assemblies**, Chap. 8
 - Acceptance Testing, 8.7

- Assembly Components, 8.3
 - Closing Devices, 8.8
 - General, 8.1
 - Inspection, Testing, and Maintenance, 8.6
 - Installation, 8.5
 - Maintenance, 8.10
 - Mounting of Smoke-Protective Curtain Assemblies, 8.2
 - Periodic Inspection and Testing, 8.9
 - Power Operators, 8.4
 - Smoke-Protective Curtain Assemblies for Hoistways, Chap. 9**
 - Assembly Components, 9.3
 - General, 9.1
 - Inspection, Testing, and Maintenance, 9.6
 - Acceptance Testing, 9.6.3
 - Maintenance, 9.6.5
 - Periodic Inspection and Testing, 9.6.4
 - Installation, 9.5
 - Mounting of Smoke-Protective Curtain Assemblies for Hoistways, 9.2
 - Power Operators, 9.4
 - Smoke-Protective Curtain Assembly**
 - Definition, 3.3.5
 - Smoke-Protective Curtain Assembly for Hoistways**
 - Definition, 3.3.6
 - Standard**
 - Definition, 3.2.7
 - Swinging Doors, Chap. 6**
 - Gasketing and Astragals, 6.7, A.6.7
 - Astragals, 6.7.2
 - Gasketing, 6.7.1
 - General, 6.1, A.6.1
 - Glazing in Sidelight and Transom Light Frames, 6.5
 - Side Panel and Transom Panel Frames, 6.6
 - Swinging Doors with Fire Protection Ratings, 6.2
 - Swinging Doors Without Fire Protection Ratings, 6.3, A.6.3
 - Builders Hardware, 6.3.6, A.6.3.6
 - Attaching Hardware to Doors and Frames, 6.3.6.8, A.6.3.6.8
 - Continuous Hinges, 6.3.6.3
 - Conventional Hinges, 6.3.6.1
 - Door Holder/Release Devices, 6.3.6.6
 - Door-Closing Devices, 6.3.6.5
 - Locks and Latches, 6.3.6.4, A.6.3.6.4
 - Pivots, 6.3.6.2
 - Protection Plates, 6.3.6.7, A.6.3.6.7
 - Clearances, 6.3.3, A.6.3.3
 - Door Frames, 6.3.2
 - Supporting Construction, 6.3.2.3
 - Doors, 6.3.1, A.6.3.1
 - Latching Hardware, 6.3.4, A.6.3.4
 - Operation of Doors, 6.3.5
 - Automatic Closing, 6.3.5.3
 - Power-Operated Doors, 6.3.5.4
 - Self-Closing, 6.3.5.1, A.6.3.5.1
 - Vision Panels in Doors, 6.4
- T-
- Temperature**
 - Ambient Temperature
 - Definition, 3.3.7.1
 - Definition, 3.3.7
 - Elevated Temperature
 - Definition, 3.3.7.2, A.3.3.7.2
 - Tenable Environment**
 - Definition, 3.3.8, A.3.3.8

Sequence of Events for the Standards Development Process

Once the current edition is published, a Standard is opened for Public Input.

Step 1 – Input Stage

- Input accepted from the public or other committees for consideration to develop the First Draft
- Technical Committee holds First Draft Meeting to revise Standard (23 weeks); Technical Committee(s) with Correlating Committee (10 weeks)
- Technical Committee ballots on First Draft (12 weeks); Technical Committee(s) with Correlating Committee (11 weeks)
- Correlating Committee First Draft Meeting (9 weeks)
- Correlating Committee ballots on First Draft (5 weeks)
- First Draft Report posted on the document information page

Step 2 – Comment Stage

- Public Comments accepted on First Draft (10 weeks) following posting of First Draft Report
- If Standard does not receive Public Comments and the Technical Committee chooses not to hold a Second Draft meeting, the Standard becomes a Consent Standard and is sent directly to the Standards Council for issuance (see Step 4) or
- Technical Committee holds Second Draft Meeting (21 weeks); Technical Committee(s) with Correlating Committee (7 weeks)
- Technical Committee ballots on Second Draft (11 weeks); Technical Committee(s) with Correlating Committee (10 weeks)
- Correlating Committee Second Draft Meeting (9 weeks)
- Correlating Committee ballots on Second Draft (8 weeks)
- Second Draft Report posted on the document information page

Step 3 – NFPA Technical Meeting

- Notice of Intent to Make a Motion (NITMAM) accepted (5 weeks) following the posting of Second Draft Report
- NITMAMs are reviewed and valid motions are certified by the Motions Committee for presentation at the NFPA Technical Meeting
- NFPA membership meets each June at the NFPA Technical Meeting to act on Standards with “Certified Amending Motions” (certified NITMAMs)
- Committee(s) vote on any successful amendments to the Technical Committee Reports made by the NFPA membership at the NFPA Technical Meeting

Step 4 – Council Appeals and Issuance of Standard

- Notification of intent to file an appeal to the Standards Council on Technical Meeting action must be filed within 20 days of the NFPA Technical Meeting
- Standards Council decides, based on all evidence, whether to issue the standard or to take other action

Notes:

1. Time periods are approximate; refer to published schedules for actual dates.
2. Annual revision cycle documents with certified amending motions take approximately 101 weeks to complete.
3. Fall revision cycle documents receiving certified amending motions take approximately 141 weeks to complete.

Committee Membership Classifications^{1,2,3,4}

The following classifications apply to Committee members and represent their principal interest in the activity of the Committee.

1. M *Manufacturer*: A representative of a maker or marketer of a product, assembly, or system, or portion thereof, that is affected by the standard.
2. U *User*: A representative of an entity that is subject to the provisions of the standard or that voluntarily uses the standard.
3. IM *Installer/Maintainer*: A representative of an entity that is in the business of installing or maintaining a product, assembly, or system affected by the standard.
4. L *Labor*: A labor representative or employee concerned with safety in the workplace.
5. RT *Applied Research/Testing Laboratory*: A representative of an independent testing laboratory or independent applied research organization that promulgates and/or enforces standards.
6. E *Enforcing Authority*: A representative of an agency or an organization that promulgates and/or enforces standards.
7. I *Insurance*: A representative of an insurance company, broker, agent, bureau, or inspection agency.
8. C *Consumer*: A person who is or represents the ultimate purchaser of a product, system, or service affected by the standard, but who is not included in (2).
9. SE *Special Expert*: A person not representing (1) through (8) and who has special expertise in the scope of the standard or portion thereof.

NOTE 1: “Standard” connotes code, standard, recommended practice, or guide.

NOTE 2: A representative includes an employee.

NOTE 3: While these classifications will be used by the Standards Council to achieve a balance for Technical Committees, the Standards Council may determine that new classifications of member or unique interests need representation in order to foster the best possible Committee deliberations on any project. In this connection, the Standards Council may make such appointments as it deems appropriate in the public interest, such as the classification of “Utilities” in the National Electrical Code Committee.

NOTE 4: Representatives of subsidiaries of any group are generally considered to have the same classification as the parent organization.

Submitting Public Input / Public Comment Through the Online Submission System

Soon after the current edition is published, a Standard is open for Public Input.

Before accessing the Online Submission System, you must first sign in at www.nfpa.org. *Note: You will be asked to sign-in or create a free online account with NFPA before using this system:*

- a. Click on Sign In at the upper right side of the page.
- b. Under the Codes and Standards heading, click on the “List of NFPA Codes & Standards,” and then select your document from the list or use one of the search features.

OR

- a. Go directly to your specific document information page by typing the convenient shortcut link of www.nfpa.org/document# (Example: NFPA 921 would be www.nfpa.org/921). Sign in at the upper right side of the page.

To begin your Public Input, select the link “The next edition of this standard is now open for Public Input” located on the About tab, Current & Prior Editions tab, and the Next Edition tab. Alternatively, the Next Edition tab includes a link to Submit Public Input online.

At this point, the NFPA Standards Development Site will open showing details for the document you have selected. This “Document Home” page site includes an explanatory introduction, information on the current document phase and closing date, a left-hand navigation panel that includes useful links, a document Table of Contents, and icons at the top you can click for Help when using the site. The Help icons and navigation panel will be visible except when you are actually in the process of creating a Public Input.

Once the First Draft Report becomes available there is a Public Comment period during which anyone may submit a Public Comment on the First Draft. Any objections or further related changes to the content of the First Draft must be submitted at the Comment stage.

To submit a Public Comment you may access the online submission system utilizing the same steps as previously explained for the submission of Public Input.

For further information on submitting public input and public comments, go to: <http://www.nfpa.org/publicinput>.

Other Resources Available on the Document Information Pages

About tab: View general document and subject-related information.

Current & Prior Editions tab: Research current and previous edition information on a Standard.

Next Edition tab: Follow the committee’s progress in the processing of a Standard in its next revision cycle.

Technical Committee tab: View current committee member rosters or apply to a committee.

Technical Questions tab: For members and Public Sector Officials/AHJs to submit questions about codes and standards to NFPA staff. Our Technical Questions Service provides a convenient way to receive timely and consistent technical assistance when you need to know more about NFPA codes and standards relevant to your work. Responses are provided by NFPA staff on an informal basis.

Products & Training tab: List of NFPA’s publications and training available for purchase.

Information on the NFPA Standards Development Process

I. Applicable Regulations. The primary rules governing the processing of NFPA standards (codes, standards, recommended practices, and guides) are the NFPA *Regulations Governing the Development of NFPA Standards (Regs)*. Other applicable rules include NFPA *Bylaws*, NFPA *Technical Meeting Convention Rules*, NFPA *Guide for the Conduct of Participants in the NFPA Standards Development Process*, and the NFPA *Regulations Governing Petitions to the Board of Directors from Decisions of the Standards Council*. Most of these rules and regulations are contained in the *NFPA Standards Directory*. For copies of the *Directory*, contact Codes and Standards Administration at NFPA Headquarters; all these documents are also available on the NFPA website at “www.nfpa.org.”

The following is general information on the NFPA process. All participants, however, should refer to the actual rules and regulations for a full understanding of this process and for the criteria that govern participation.

II. Technical Committee Report. The Technical Committee Report is defined as “the Report of the responsible Committee(s), in accordance with the Regulations, in preparation of a new or revised NFPA Standard.” The Technical Committee Report is in two parts and consists of the First Draft Report and the Second Draft Report. (See *Regs* at Section 1.4.)

III. Step 1: First Draft Report. The First Draft Report is defined as “Part one of the Technical Committee Report, which documents the Input Stage.” The First Draft Report consists of the First Draft, Public Input, Committee Input, Committee and Correlating Committee Statements, Correlating Notes, and Ballot Statements. (See *Regs* at 4.2.5.2 and Section 4.3.) Any objection to an action in the First Draft Report must be raised through the filing of an appropriate Comment for consideration in the Second Draft Report or the objection will be considered resolved. [See *Regs* at 4.3.1(b).]

IV. Step 2: Second Draft Report. The Second Draft Report is defined as “Part two of the Technical Committee Report, which documents the Comment Stage.” The Second Draft Report consists of the Second Draft, Public Comments with corresponding Committee Actions and Committee Statements, Correlating Notes and their respective Committee Statements, Committee Comments, Correlating Revisions, and Ballot Statements. (See *Regs* at 4.2.5.2 and Section 4.4.) The First Draft Report and the Second Draft Report together constitute the Technical Committee Report. Any outstanding objection following the Second Draft Report must be raised through an appropriate Amending Motion at the NFPA Technical Meeting or the objection will be considered resolved. [See *Regs* at 4.4.1(b).]

V. Step 3a: Action at NFPA Technical Meeting. Following the publication of the Second Draft Report, there is a period during which those wishing to make proper Amending Motions on the Technical Committee Reports must signal their intention by submitting a Notice of Intent to Make a Motion (NITMAM). (See *Regs* at 4.5.2.) Standards that receive notice of proper Amending Motions (Certified Amending Motions) will be presented for action at the annual June NFPA Technical Meeting. At the meeting, the NFPA membership can consider and act on these Certified Amending Motions as well as Follow-up Amending Motions, that is, motions that become necessary as a result of a previous successful Amending Motion. (See 4.5.3.2 through 4.5.3.6 and Table 1, Columns 1-3 of *Regs* for a summary of the available Amending Motions and who may make them.) Any outstanding objection following action at an NFPA Technical Meeting (and any further Technical Committee consideration following successful Amending Motions, see *Regs* at 4.5.3.7 through 4.6.5.3) must be raised through an appeal to the Standards Council or it will be considered to be resolved.

VI. Step 3b: Documents Forwarded Directly to the Council. Where no NITMAM is received and certified in accordance with the Technical Meeting Convention Rules, the standard is forwarded directly to the Standards Council for action on issuance. Objections are deemed to be resolved for these documents. (See *Regs* at 4.5.2.5.)

VII. Step 4a: Council Appeals. Anyone can appeal to the Standards Council concerning procedural or substantive matters related to the development, content, or issuance of any document of the NFPA or on matters within the purview of the authority of the Council, as established by the Bylaws and as determined by the Board of Directors. Such appeals must be in written form and filed with the Secretary of the Standards Council (see *Regs* at Section 1.6). Time constraints for filing an appeal must be in accordance with 1.6.2 of the *Regs*. Objections are deemed to be resolved if not pursued at this level.

VIII. Step 4b: Document Issuance. The Standards Council is the issuer of all documents (see Article 8 of *Bylaws*). The Council acts on the issuance of a document presented for action at an NFPA Technical Meeting within 75 days from the date of the recommendation from the NFPA Technical Meeting, unless this period is extended by the Council (see *Regs* at 4.7.2). For documents forwarded directly to the Standards Council, the Council acts on the issuance of the document at its next scheduled meeting, or at such other meeting as the Council may determine (see *Regs* at 4.5.2.5 and 4.7.4).

IX. Petitions to the Board of Directors. The Standards Council has been delegated the responsibility for the administration of the codes and standards development process and the issuance of documents. However, where extraordinary circumstances requiring the intervention of the Board of Directors exist, the Board of Directors may take any action necessary to fulfill its obligations to preserve the integrity of the codes and standards development process and to protect the interests of the NFPA. The rules for petitioning the Board of Directors can be found in the *Regulations Governing Petitions to the Board of Directors from Decisions of the Standards Council* and in Section 1.7 of the *Regs*.

X. For More Information. The program for the NFPA Technical Meeting (as well as the NFPA website as information becomes available) should be consulted for the date on which each report scheduled for consideration at the meeting will be presented. To view the First Draft Report and Second Draft Report as well as information on NFPA rules and for up-to-date information on schedules and deadlines for processing NFPA documents, check the NFPA website (www.nfpa.org/docinfo) or contact NFPA Codes & Standards Administration at (617) 984-7246.



Xchange™

The place to connect online with your fire, electrical, and life safety peers

Have a question about the code or standard you're reading now?

NFPA Xchange™ can help!

NFPA Xchange™ brings together over 30,000 professionals worldwide, asking and answering each other's questions, sharing ideas, and discussing the issues impacting your industry today.

NFPA Xchange™ is free to join and offers:

- A robust collection of previously asked and answered questions to search
- Access to thousands of peers for problem-solving and on-the-job advice
- NFPA blogs, white papers, and webinars in one convenient place

NFPA members also enjoy Xchange™ **Members Only**, the online space for technical questions* answered by NFPA staff, exclusive NFPA live events, and premier access to curated content.

Join NFPA Xchange™ TODAY!

www.nfpa.org/xchange

Xchange Today. Safer Tomorrow.

*For the full terms of use, please visit nfpa.org/standard_items/terms-of-use#xchange. NFPA® is a registered trademark of the National Fire Protection Association, Quincy, MA 02169.